

Troubleshooting

1104E and 1106E Engines

RF11-Up (Engine)
RH11-Up (Engine)
RK11-Up (Engine)
VK11-Up (Engine)

Important Safety Information

Most accidents that involve product operation, maintenance and repair are caused by failure to observe basic safety rules or precautions. An accident can often be avoided by recognizing potentially hazardous situations before an accident occurs. A person must be alert to potential hazards. This person should also have the necessary training, skills and tools to perform these functions properly.

Improper operation, lubrication, maintenance or repair of this product can be dangerous and could result in injury or death.

Do not operate or perform any lubrication, maintenance or repair on this product, until you have read and understood the operation, lubrication, maintenance and repair information.

Safety precautions and warnings are provided in this manual and on the product. If these hazard warnings are not heeded, bodily injury or death could occur to you or to other persons.

The hazards are identified by the "Safety Alert Symbol" and followed by a "Signal Word" such as "DANGER", "WARNING" or "CAUTION". The Safety Alert "WARNING" label is shown below.



The meaning of this safety alert symbol is as follows:

Attention! Become Alert! Your Safety is Involved.

The message that appears under the warning explains the hazard and can be either written or pictorially presented.

Operations that may cause product damage are identified by "NOTICE" labels on the product and in this publication.

Perkins cannot anticipate every possible circumstance that might involve a potential hazard. The warnings in this publication and on the product are, therefore, not all inclusive. If a tool, procedure, work method or operating technique that is not specifically recommended by Perkins is used, you must satisfy yourself that it is safe for you and for others. You should also ensure that the product will not be damaged or be made unsafe by the operation, lubrication, maintenance or repair procedures that you choose.

The information, specifications, and illustrations in this publication are on the basis of information that was available at the time that the publication was written. The specifications, torques, pressures, measurements, adjustments, illustrations, and other items can change at any time. These changes can affect the service that is given to the product. Obtain the complete and most current information before you start any job. Perkins dealers have the most current information available.



When replacement parts are required for this product Perkins recommends using Perkins replacement parts or parts with equivalent specifications including, but not limited to, physical dimensions, type, strength and material.

Failure to heed this warning can lead to premature failures, product damage, personal injury or death.

Table of Contents

Troubleshooting Section

Electronic Troubleshooting

| | |
|---|----|
| System Overview | 5 |
| Glossary | 9 |
| Electronic Service Tools | 12 |
| Diagnostic Codes | 13 |
| Indicator Lamps | 15 |
| Replacing the ECM | 18 |
| Self-Diagnostics | 19 |
| Sensors and Electrical Connectors | 20 |
| Engine Wiring Information | 26 |

Programming Parameters

| | |
|------------------------------|----|
| Programming Parameters | 32 |
| Factory Passwords | 32 |
| Flash Programming | 32 |

System Configuration Parameters

| | |
|---------------------------------------|----|
| System Configuration Parameters | 34 |
|---------------------------------------|----|

Troubleshooting without a Diagnostic Code

| | |
|---|----|
| Alternator Noise (Noisy Operation) | 35 |
| Alternator Will Not Charge (Charging Problem) | 35 |
| Battery | 35 |
| Can Not Reach Top Engine RPM | 36 |
| Coolant in Engine Oil | 38 |
| Coolant Temperature Is Too High | 39 |
| ECM Will Not Accept Factory Passwords | 40 |
| ECM Will Not Communicate with Other Systems or Display Modules | 40 |
| Electronic Service Tool Will Not Communicate with ECM | 40 |
| Engine Cranks but Will Not Start | 41 |
| Engine Has Early Wear | 43 |
| Engine Misfires, Runs Rough or Is Unstable | 43 |
| Engine Oil in Cooling System | 46 |
| Engine Speed Does Not Change | 46 |
| Engine Stalls at Low RPM | 47 |
| Engine Vibration | 48 |
| Engine Will Not Crank | 49 |
| Excessive Black Smoke | 50 |
| Excessive Engine Oil Consumption | 51 |
| Excessive Valve Lash | 52 |
| Excessive White Smoke | 53 |
| Intake Air Temperature Is Too High | 54 |
| Intermittent Engine Shutdown | 55 |
| Intermittent Low Power or Power Cutout | 56 |
| Low Engine Oil Pressure | 58 |
| Low Power/Poor or No Response to Throttle | 59 |
| Mechanical Noise (Knock) in Engine | 61 |
| Noise Coming from Cylinder | 61 |
| Poor Acceleration or Response | 62 |

Troubleshooting with a Diagnostic Code

| | |
|---|----|
| CID 0041 FMI 03 8v Sensor Power Supply, Voltage More Than Normal | 64 |
| CID 0041 FMI 04 8v Sensor Power Supply, Voltage Less Than Normal | 64 |

| | |
|--|----|
| CID 0091 FMI 02 Throttle Demand Sensor Erratic Or Intermittent | 64 |
| CID 0091 FMI 03 Throttle Demand Sensor Open Circuit Or Shorted High | 65 |
| CID 0091 FMI 04 Throttle Demand Sensor Shorted Low | 65 |
| CID 0091 FMI 08 Throttle Demand Sensor Abnormal Signal | 66 |
| CID 0091 FMI 12 Throttle Demand Sensor Out Of Calibration | 66 |
| CID 0100 FMI 03 Engine Oil Pressure Sensor Open Circuit Or Shorted High | 66 |
| CID 0100 FMI 04 Engine Oil Pressure Sensor Shorted Low | 67 |
| CID 0100 FMI 10 Engine Oil Pressure Sensor, Power Supply Open Circuit | 67 |
| CID 0102 FMI 03 Intake Manifold Pressure Sensor, Open Circuit Or Shorted High | 67 |
| CID 0102 FMI 04 Intake Manifold Pressure Sensor Shorted Low | 68 |
| CID 0102 FMI 10 Intake Manifold Pressure Sensor Power Supply Open Circuit | 68 |
| CID 0105 FMI 03 Intake Manifold Temperature Sensor Open Circuit Or Shorted High | 69 |
| CID 0105 FMI 04 Intake Manifold Temperature Sensor Shorted Low | 69 |
| CID 0110 FMI 03 Engine Coolant Temperature Sensor Open Circuit Or Shorted High | 69 |
| CID 0110 FMI 04 Engine Coolant Temperature Sensor Shorted Low | 70 |
| CID 0174 FMI 02 Fuel Temperature Sensor Erratic, Intermittent | 70 |
| CID 0247 FMI 09 J1939 Datalink, Abnormal Update | 71 |
| CID 0253 FMI 02 Incorrect ECM Software | 71 |
| CID 0262 FMI 03 5v Sensor Power Supply, Voltage More Than Normal | 71 |
| CID 0262 FMI 04 5v Sensor Power Supply, Voltage Less Than Normal | 72 |
| CID 0266 FMI 02 Incorrect Crank-without-inject inputs | 72 |
| CID 0320 FMI 02 Speed And Timing Sensor Intermittent Loss Of Signal | 73 |
| CID 0320 FMI 11 Speed And Timing Sensor Loss Of Signal | 73 |
| CID 0342 FMI 02 Speed And Timing Sensor No.2 Intermittent Signal | 73 |
| CID 0774 FMI 02 Throttle Demand Sensor No.2 Erratic Or Intermittent | 74 |
| CID 0774 FMI 03 Throttle Demand Sensor No.2 Open Circuit Or Shorted High | 74 |
| CID 0774 FMI 04 Throttle Demand Sensor No.2 Shorted Low | 75 |
| CID 0774 FMI 08 Throttle Demand Sensor No.2 Abnormal Signal | 75 |
| CID 0774 FMI 12 Throttle Demand Sensor No.2 Out Of Calibration | 75 |
| CID 1627 FMI 03 Fuel Injection Pump Relay Did Not Turn Off | 76 |
| CID 1684 FMI 00 Fuel Injection Pump, Fuel Temperature More Than Normal | 76 |
| CID 1684 FMI 02 Fuel Injection Pump, Software Failure | 77 |

| | | | |
|---|-----|--|-----|
| CID 1684 FMI 03 Fuel Injection Pump, Fuelling Fault | 77 | Engine Temperature Sensor Open or Short Circuit - Test | 171 |
| CID 1684 FMI 04 Fuel Injection Pump, Supply Voltage Fault | 77 | Fuel Injection Pump Circuit - Test | 178 |
| CID 1684 FMI 05 Fuel Injection Pump, Invalid Pulse Width | 78 | Indicator Lamp Circuit - Test | 195 |
| CID 1684 FMI 07 Fuel Injection Pump, Mechanical Fault | 78 | Mode Selection Circuit - Test | 198 |
| CID 1684 FMI 08 Fuel Injection Pump, Crankshaft Reference Fault | 79 | Set Speed Circuit - Test | 204 |
| CID 1684 FMI 09 Fuel Injection Pump, CAN Fault | 80 | Throttle Switch Circuit - Test | 212 |
| CID 1684 FMI 10 Fuel Injection Pump, Fuel Shutoff Signal Error | 80 | | |
| CID 1684 FMI 11 Fuel Injection Pump, Internal Sensor Fault | 81 | Index Section | |
| CID 1684 FMI 12 Fuel Injection Pump, Device Failure | 81 | Index | 221 |
| CID 1684 FMI 14 Fuel Injection Pump, No Communications | 82 | | |
| CID 1743 FMI 02 Engine Speed Mode Selection Switch State, Invalid State | 83 | | |
| CID 1894 FMI 02 Set Speed Control Disengage Switch State, Invalid State | 83 | | |
| CID 1895 FMI 02 Set Speed Control Speed Toggle Switch, Invalid State | 83 | | |
| Troubleshooting with an Event Code | | | |
| Event Codes | 85 | | |
| E015 High Engine Coolant Temperature Derate .. | 85 | | |
| E016 High Engine Coolant Temperature Shutdown | 85 | | |
| E017 High Engine Coolant Temperature Warning | 85 | | |
| E025 High Intake Air Temperature Derate | 86 | | |
| E027 High Intake Air Temperature Warning | 86 | | |
| E040 Low Engine Oil Pressure Shutdown | 86 | | |
| E054 High Fuel Temperature Derate | 87 | | |
| E056 High Fuel Temperature Warning | 88 | | |
| E100 Low Engine Oil Pressure Warning | 89 | | |
| E190 Engine Overspeed Warning | 90 | | |
| E442 Engine Failed to Stop with a No-Fuel Command | 90 | | |
| E883 Engine Failed To Stop When Fuel Solenoid Disengaged | 91 | | |
| Diagnostic Functional Tests | | | |
| 5 Volt Engine Pressure Sensor Supply Circuit - Test | 92 | | |
| Air Inlet Heater Circuit - Test | 99 | | |
| Analog Throttle Position Sensor Circuit - Test | 104 | | |
| CAN Data Link Circuit - Test | 113 | | |
| Data Link Circuit - Test | 118 | | |
| Digital Throttle Position Sensor Circuit - Test | 126 | | |
| Electrical Connectors - Inspect | 135 | | |
| Electrical Power Supply Circuit - Test | 146 | | |
| Engine Oil Level Switch Circuit - Test | 152 | | |
| Engine Pressure Sensor Open or Short Circuit - Test | 157 | | |
| Engine Speed/Timing Sensor Circuit - Test | 164 | | |

Troubleshooting Section

Electronic Troubleshooting

i01798100

System Overview

System Operation

The 1104 models RF, RH, RK and 1106 model VK engines were designed for electronic control. The engines include an Electronic Control Module (ECM), a fuel injection pump that is electronically controlled, and a collection of engine sensors. The ECM controls the engine operating parameters through the software within the ECM and the inputs from the various sensors. The software contains parameters that control the engine operation. The parameters include all of the operating maps and customer selected parameters.

Electronic Controls

Electronically Controlled Fuel System

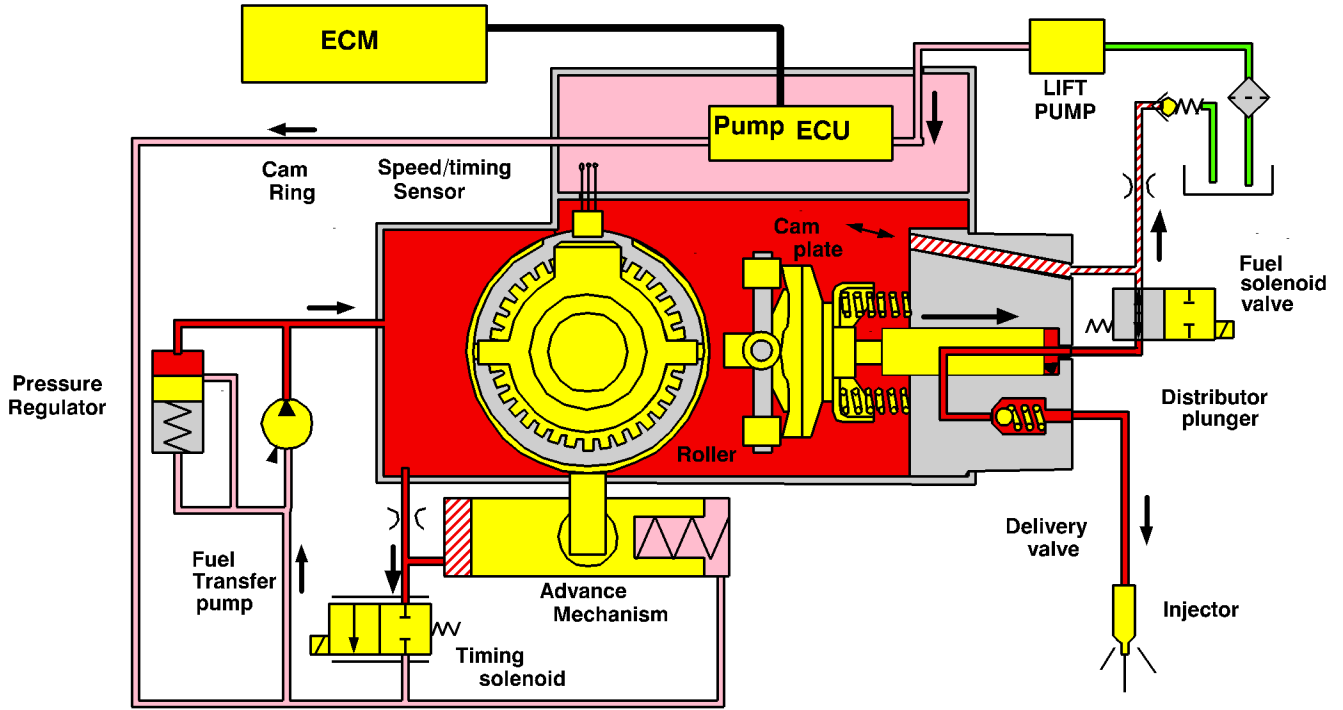

Illustration 1

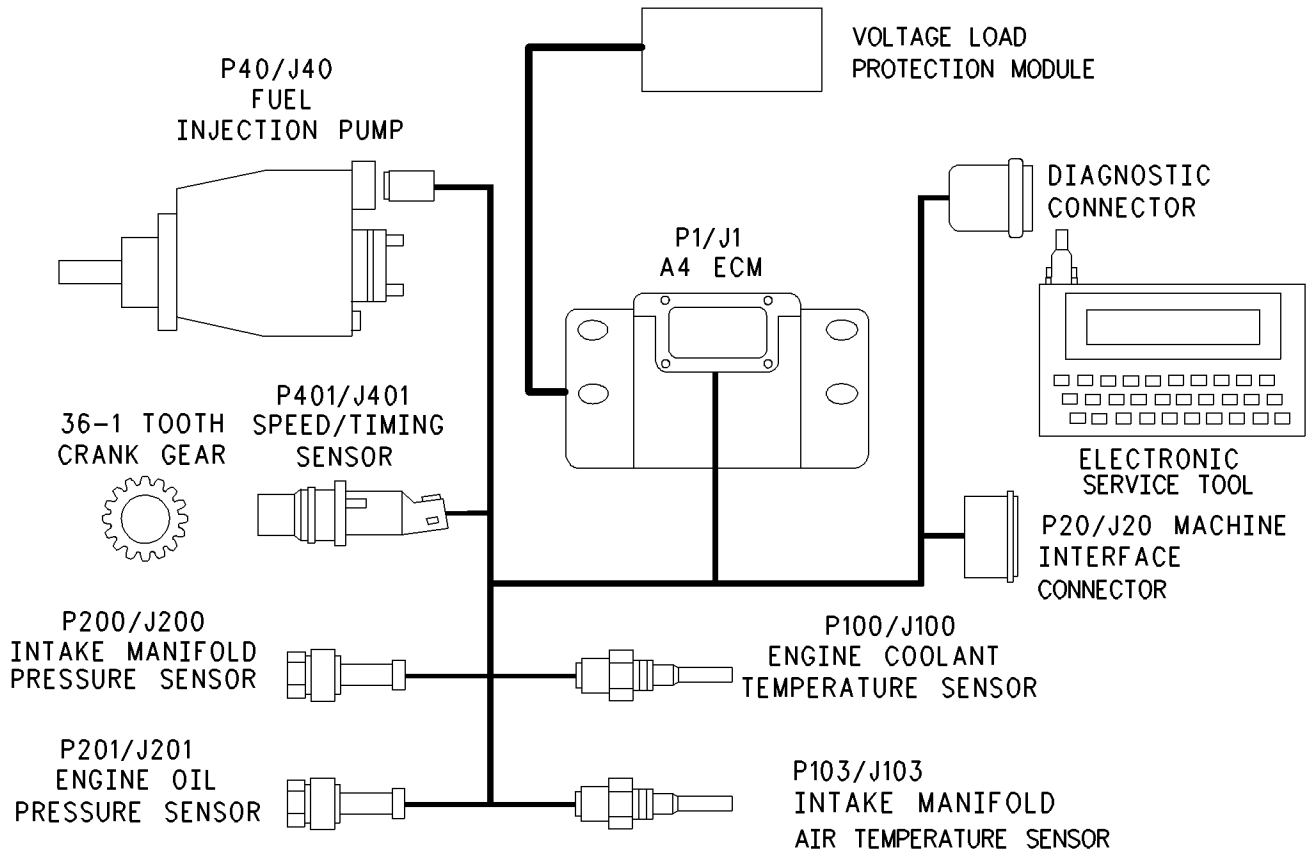

Illustration 2

g00954204

The electronic system consists of the Electronic Control Module (ECM), the engine sensors, and the Machine Interface Connector (MIC). The ECM is the computer. The personality module is the software for the computer. The personality module contains the operating maps. The operating maps define the following characteristics of the engine:

- Horsepower
- Torque curves
- Engine speed (rpm)

Engine Governor

The electronic controls determine the injection timing and the amount of fuel that is delivered to the cylinders. These decisions are based on the actual conditions and the desired conditions at any given time.

The governor compares the desired engine speed to the actual engine speed. The actual engine speed is determined through the crankshaft position sensor. If the desired engine speed is greater than the actual engine speed, the governor injects more fuel in order to increase engine speed.

Timing Considerations

Once the governor has determined the amount of fuel that is required, the governor must determine the timing of the fuel injection. Fuel injection timing is determined by the ECM after considering input from the following components:

- Engine coolant temperature sensor
- The sensor for the intake manifold air temperature
- The sensor for the intake manifold pressure

At start-up, the ECM determines the top dead center position of the number 1 cylinder from the speed/timing sensor in the fuel injection pump. The ECM decides when fuel injection should occur relative to the top dead center position. The ECM provides the signal to the fuel injection pump spill valve which stops fuel flow to the low pressure side. The ECM then forces fuel to flow to the fuel injector nozzles at the desired time. The ECM adjusts timing for the best engine performance, the best fuel economy and the best control of exhaust emissions. Actual timing cannot be viewed with an electronic service tool. Also, the desired timing cannot be viewed with an electronic service tool.

Fuel Injection

The personality module inside the ECM sets certain limits on the amount of fuel that can be injected. The FRC Limit is a limit that is based on intake manifold air pressure and engine rpm. The FRC Limit is used to control the air/fuel ratio in order to control the engine's exhaust emissions. When the ECM senses a higher intake manifold air pressure, the ECM increases the FRC Limit. A higher intake manifold air pressure indicates that there is more air in the cylinder. When the ECM increases the FRC Limit, the ECM allows more fuel into the cylinder.

The Rated Fuel Limit is a limit that is based on the power rating of the engine and on the engine rpm. The Rated Fuel Limit enables the engine power and torque outputs to conform to the power and torque curves of a specific engine model.

These limits are in the personality module and these limits cannot be changed.

Diagnostic Codes

When the ECM detects an engine problem, the ECM generates a diagnostic code. Also, the ECM logs the diagnostic code in order to indicate the time of the problem's occurrence. The ECM also logs the number of occurrences of the problem. There are two types of diagnostic fault codes. There are fault codes and event codes.

Diagnostic Fault Codes

Diagnostic fault codes are provided in order to indicate that an electrical problem or an electronic problem has been detected by the ECM. In some cases, the engine performance can be affected when the condition that is causing the code exists. More frequently, the operator cannot detect any difference in the engine performance.

If the operator indicates that a performance problem occurs, the diagnostic code may indicate the cause of the problem. Use either a laptop computer or a hand held diagnostic tool to access the diagnostic codes. The problem should then be corrected.

If the operator does not indicate a problem with the engine performance and a diagnostic code is logged by the ECM. This situation indicates that the ECM detected an abnormal engine condition, but the abnormal condition did not affect engine performance. In this situation, the system has no faults except when either of the following conditions exist:

- There are several occurrences of the diagnostic code in a very short period of time.
- The ECM is indicating an active code at the present time.

Diagnostic Event Codes

Diagnostic event codes are used to indicate that some operational problem has been detected in the engine by the ECM. This does not indicate an electronic malfunction.

Programmable Parameters

Certain parameters that affect the engine operation may be changed with electronic service tools. The parameters are stored in the ECM, and the parameters are protected from unauthorized changes by passwords. These parameters are System Configuration Parameters.

System Configuration Parameters are set at the factory. System Configuration Parameters affect emissions or power ratings within the engine. Factory passwords must be obtained and factory passwords must be used to change the System Configuration Parameters.

Passwords

System Configuration Parameters are protected by factory passwords. Factory passwords are calculated on a computer system that is available only to Perkins distributors. Since factory passwords contain alphabetic characters, only an electronic service tool may change System Configuration Parameters. System Configuration Parameters affect the power rating or the emissions.

Refer to Troubleshooting, "Programming Parameters" and Troubleshooting, "Factory Passwords".

i01798101

Glossary

Active Diagnostic Code – An active diagnostic code alerts the operator or the service technician that an electronic system malfunction is currently present. Refer to the term “Diagnostic Code” in this glossary.

Alternating Current (AC) – Alternating current is an electric current that reverses direction at a regular interval that is reoccurring.

Before Top Dead Center (BTC) – BTDC is the 180 degrees of crankshaft rotation before the piston reaches the top dead center position in the normal direction of rotation.

Boost Pressure (Engines that are turbocharged) – The difference between the turbocharger outlet pressure and atmospheric pressure is commonly referred to as boost pressure. The sensor for the intake manifold air pressure measures the amount of boost.

Breakout Harness – The breakout harness is a test harness that is designed to connect into the engine harness. This connection allows a normal circuit operation and the connection simultaneously provides a Breakout T in order to measure the signals.

Bypass Circuit – A bypass circuit is a circuit that is used as a substitute circuit for an existing circuit. A bypass circuit is typically used as a test circuit.

CAN Data Link – The CAN Data Link is a serial communications port that is used for communication with other microprocessor based devices. In this application, the CAN Data Link connects the ECM to the Electronic Fuel Injection Pump.

Code – Refer to “Diagnostic Code” or “Event Code”.

Cold Mode – Cold mode is a mode for cold starting and for cold engine operation that includes timing that is retarded and low idle that is raised. This mode is used for engine protection, reduced smoke emissions and faster warm up time.

Communication Adapter Tool – The communication adapter provides a communication link between the ECM and the Electronic Service Tool.

Component Identifier (CID) – The CID is a number that identifies the specific component of the electronic control system that has experienced a diagnostic code.

Coolant Level Sensor – The coolant level sensor detects the absence or presence of coolant at the probe. The sensor then sends a signal to the ECM.

Coolant Temperature Sensor – The coolant temperature sensor detects the engine coolant temperature for cold mode operation and for Engine Monitoring.

Data Link – The Data Link is a serial communication port that is used for communication with other microprocessor based devices.

Desired Engine Speed – The desired engine speed is input to the electronic governor within the ECM. The electronic governor uses the signal from the throttle position sensor, the engine speed/timing sensor, and other sensors in order to determine the desired engine speed.

Diagnostic Code – A diagnostic code is sometimes referred to as a fault code. These codes indicate an electronic system malfunction.

Diagnostic Lamp – A diagnostic lamp is sometimes called the check engine light. The diagnostic lamp is used to warn the operator of the presence of an active diagnostic code.

Digital Sensor Return – The common line (ground) from the ECM is used as ground for the digital sensors.

Digital Sensors – Digital sensors produce a pulse width modulated signal. Digital sensors are supplied with +8 VDC from the ECM.

Digital Sensor Supply – The +8 VDC supply from the ECM is used in order to power the digital sensors.

Direct Current (DC) – Direct current is the type of current that flows consistently in only one direction.

DT, DT Connector, or Deutsch DT – This is a type of connector that is used on Perkins engines. The connectors are manufactured by Deutsch.

Duty Cycle – Refer to “Pulse Width Modulation”.

Electronic Engine Control – The electronic engine control is a complete electronic system. The electronic engine control monitors the engine operation under all conditions. The electronic engine control also controls the engine operation under all conditions.

Electronic Service Tool – The electronic service tool allows a computer (PC) to communicate with the ECM.

Electronic Control Module (ECM) – The ECM is the control computer of the engine. The ECM provides power to the electronics. The ECM monitors data that is input from the sensors of the engine. The ECM acts as a governor in order to control the speed and the power of the engine.

Engine Monitoring – Engine Monitoring is the part of the electronic engine control that monitors the sensors. This also warns the operator of detected problems.

Engine Oil Pressure Sensor – The engine oil pressure sensor measures engine oil pressure. The sensor sends the signal to the ECM.

Engine Speed/Timing Sensor – The engine speed/timing sensor provides a variable amplitude and pulse width modulated signal to the ECM. The ECM interprets this signal as the crankshaft position and the engine speed.

Event Code – An event code may be activated in order to indicate an abnormal engine operating condition. These codes usually indicate a mechanical problem instead of an electrical system problem.

Failure Mode Identifier (FMI) – This identifier indicates the type of failure that has been experienced by the component. The FMI has been adopted from the SAE practice of J1587 diagnostics.

Flash Programming – Flash programming is the method of programming or updating an ECM with an electronic service tool over the data link instead of replacing components.

Fuel Ratio Control (FRC) – The FRC is a limit that is based on the control of the ratio of the fuel to air. The FRC is used for purposes of emission control. When the ECM senses a higher intake manifold air pressure (more air into the cylinder), the FRC increases the FRC Limit (more fuel into the cylinder).

Fuel Temperature Sensor – The fuel temperature sensor detects the fuel temperature. The ECM monitors the fuel temperature and the ECM adjusts the calculated fuel rate accordingly.

Full Load Setting (FLS) – The FLS is the number that represents the fuel system adjustment. This adjustment is made at the factory in order to fine tune the fuel system. The correct value for this parameter is stamped on the engine information ratings plate. This parameter must be programmed.

Full Torque Setting (FTS) – The FTS is similar to the full load setting. This parameter must be programmed.

Harness – The harness is the bundle of wiring (loom) that connects all components of the electronic system.

Hertz (Hz) – Hertz is the measure of electrical frequency in cycles per second.

Intake Manifold Air Temperature Sensor – The intake manifold air temperature sensor detects the air temperature in the intake manifold. The ECM monitors the air temperature and other data in the intake manifold in order to adjust injection timing and other performance functions.

Intake Manifold Pressure Sensor – The air pressure in the intake manifold may be different to the air pressure outside the engine (atmospheric pressure). This difference in air pressure can be caused by variable air velocity within the manifold. The difference in pressure can also be caused by an increase in air pressure by a turbocharger (if equipped). The sensor for the intake manifold air pressure measures the difference between atmospheric pressure and the air pressure in the intake manifold.

Integrated Electronic Controls – The engine is designed with the electronic controls as a necessary part of the system. The engine will not operate without the electronic controls.

J1939 CAN Data Link – This data link is a SAE diagnostic communications data link that is used to communicate between the ECM and the electronic service tool.

Logged Diagnostic Codes – Logged diagnostic codes are codes which are stored in the memory. These codes are meant to be an indicator of possible causes for intermittent problems. Refer to the term “Diagnostic Code” in this glossary for more information.

MAB – This is a Bosch acronym for the fuel shutoff inside the “VPM30” Fuel Injection Pump. The MAB is a signal wire from the ECM to the Fuel Injection Pump.

Open Circuit – An open circuit is a condition that is caused by an open switch, or by an electrical wire or a connection that is broken. When this condition exists, the signal or the supply voltage can no longer reach the intended destination.

Parameter – A parameter is a value or a limit that is programmable. This helps determine specific characteristics or behaviors of the engine.

Password – A password is a group of numeric characters or a group of alphanumeric characters that is designed to restrict access to parameters. The electronic system requires correct passwords in order to change some parameters (Factory Passwords). Refer to Troubleshooting, “Factory Passwords” for more information.

Personality Module – This module is inside the ECM. The module contains all the instructions (software) for the ECM and the module contains the performance maps for a specific engine. The personality module may be reprogrammed through flash programming.

Power Cycled – Power cycled happens when power to the ECM is cycled: ON, OFF, and ON. Power cycled refers to the action of cycling the keyswitch from any position to the OFF position, and to the START/RUN position.

Pulse Width Modulation (PWM) – The PWM is a signal that consists of pulses that are of variable width. These pulses occur at fixed intervals. The ratio of “TIME ON” versus total “TIME OFF” can be varied. This ratio is also referred to as a duty cycle.

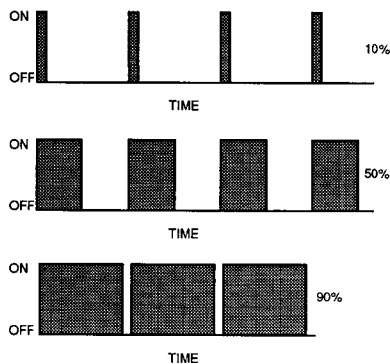

Illustration 3

g00284479

Rated Fuel Limit – This term indicates the maximum allowable fuel position (longest injection pulse). This position will produce rated power for this engine configuration.

Reference Voltage – Reference voltage is a regulated voltage and a steady voltage that is supplied by the ECM to a sensor. The reference voltage is used by the sensor to generate a signal voltage.

Sensor – A sensor is a device that is used to detect a change in pressure, temperature, or mechanical movement. The information that is detected is converted into an electrical signal.

Short Circuit – A short circuit is a condition that has an electrical circuit that is inadvertently connected to an undesirable point. An example of a short circuit is a wire which rubs against a vehicle frame and this rubbing eventually wears off the wire insulation. Electrical contact with the frame is made and a short circuit results.

Signal – The signal is a voltage or a waveform that is used in order to transmit information typically from a sensor to the ECM.

Supply Voltage – The supply voltage is a constant voltage that is supplied to a component in order to provide the electrical power that is required for the component to operate. The power may be generated by the ECM or the power may be battery voltage that is supplied by the engine wiring.

System Configuration Parameters – System configuration parameters are parameters that affect emissions and/or operating characteristics of the engine.

Throttle Position – The throttle position is the interpretation by the ECM of the signal from the throttle position sensor or the throttle switch.

Throttle Position Sensor – The throttle position sensor is an electronic sensor that is connected to an accelerator pedal or a hand lever. This sensor sends a PWM signal to the ECM that is used to calculate desired engine speed.

Throttle Switch – The throttle switch sends a signal to the ECM that is used to calculate desired engine speed.

Top Dead Center – Top dead center refers to the crankshaft position when the engine piston position is at the highest point of travel. The engine must be turned in the normal direction of rotation in order to reach this point.

Total Tattletale – The total tattletale is the total number of changes to all the parameters that are stored in the ECM.

Voltage Load Protection Module (“VLPM”) – The “VLPM” monitors the voltage of the electronic system. The “VLPM” will eliminate any high voltage conditions that occur. The “VLPM” will protect the fuel injection pump from any high voltage conditions that could damage the pump.

i01798102

Table 1

Electronic Service Tools

Electronic Service Tools are designed to help the service technician with the diagnosis and repair of electronic engines. Several tools are available to assist the service technician.

Some of the included Diagnostic Functional Tests in this manual require two short jumper wires. The jumper wires are used to check the continuity of some wiring harness circuits by shorting two adjacent terminals together in a connector.

A long extension wire may also be needed to check the continuity of some wiring harness circuits.

Electronic Service Tool

The electronic service tool can display the following information:

- Parameters
- Event codes
- Diagnostic codes
- Engine configuration

The electronic service tool can be used by the technician to perform the following functions:

- Diagnostic tests
- Sensor calibrations
- Flash programming
- Set parameters

The following components are required to use the electronic service tool to service the engine.

| Required Electronic Service Tools for the Use of the Electronic Service Tool | |
|--|--|
| Part Number | Description |
| N/A | <p>Required IBM compatible PC with 266 MHz Pentium processor</p> <p>64 MB of RAM 400 MB of available hard drive space CD-ROM drive 3.5" 1.44 MB floppy disk drive VGA monitor or display (800 x 600) Microsoft® Windows 2000, XP, ME, NT 4.0, 98, or 95 RS232 port with 16550AF UART</p> |
| N/A | <p>Recommended IBM compatible PC with 450 MHz Pentium III processor</p> <p>128 MB of RAM 1 GB of available hard drive space 40X speed CD-ROM drive or 8X speed DVD drive 3.5" 1.44 MB floppy disk drive Super VGA monitor or display (800 x 600) Microsoft® Windows 2000, XP, ME, NT 4.0, or 98 RS232 port with 16550AF UART</p> |

Connecting the Electronic Service Tool and the Communication Adapter II

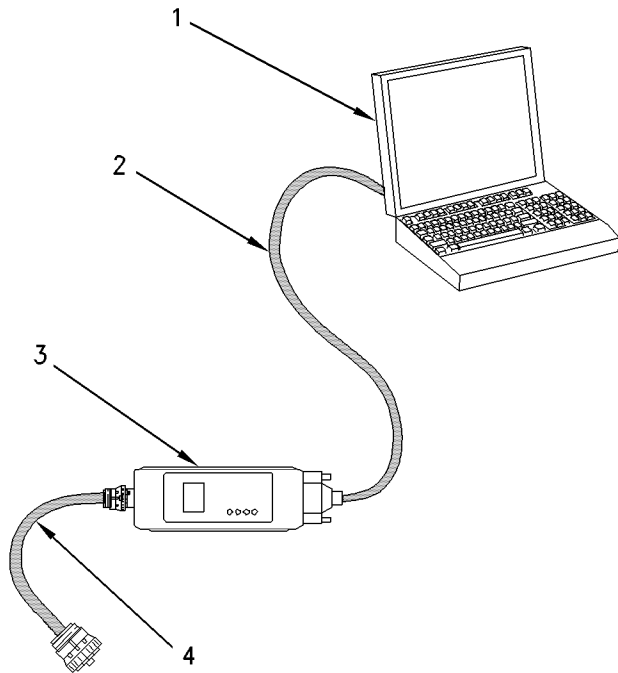

Illustration 4

g00647144

- (1) Personal computer (PC)
- (2) Adapter Cable (Computer Serial Port)
- (3) Communication Adapter II
- (4) Adapter Cable Assembly

Note: Items (2), (3), and (4) are part of the Communication Adapter II Gp.

Use the following procedure to connect the Electronic Service Tool and the Communication Adapter II.

1. Turn the keyswitch to the OFF/RESET position. If the keyswitch is not placed in the OFF/RESET position, the engine may start.
2. Connect cable (2) between the "COMPUTER" end of communication adapter (3) and the RS232 serial port of PC (1).
3. Connect cable (4) between the "DATA LINK" end of communication adapter (3) and the service tool connector.
4. Turn the keyswitch to the ON position. If the electronic service tool and the communication adapter do not communicate with the ECM, refer to Troubleshooting, "Electronic Service Tool Will Not Communicate With ECM".

Support for the Electronic Service Tool

For authorization and ordering information, contact Perkins Help Desk - Irlam.

If you are having problems with the software, you can contact the Perkins Service Systems Support Center.

Optional Service Tools

The following table contains service tools that may be helpful to service the engine.

Table 2

| Optional Service Tools | |
|------------------------|--------------------------------------|
| Part Number | Description |
| N/A | Suitable Digital Multimeter |
| N/A | Suitable Breakout T (70 pin) |
| N/A | Suitable Crimp Tool |
| N/A | Suitable Cylinder Pressure Indicator |
| N/A | Suitable Battery Load Tester |

i02270470

Diagnostic Codes

This list identifies the respective faults for the CID FMI and the J Code FMI codes. The CID FMI codes are displayed on a laptop computer. The J Code FMI codes are displayed on a Diagnostic Code Reader. The Diagnostic Code Reader is also known as the Hand Held Tool.

The Component Identifier (CID) is a number that identifies the specific component that caused a diagnostic code to be logged.

The Failure Mode Identifier (FMI) is a number that indicates the type of failure that has been experienced by the component.

The J1939 Code is another system that identifies the specific component that caused a diagnostic code to be logged.

Note: Event codes are not supported by J1939 numbers. Event codes use (CID) and (FMI) numbers. The following (FMI) numbers 0, 1, 15, 16, 17, and 18 are used for event codes.

Table 3

| CID FMI Code | J Code FMI Code | Fault Description |
|--------------|-----------------|--|
| 0041 03 | J0678 03 | 8V Sensor Power Supply, voltage more than normal |
| 0041 04 | J0678 04 | 8V Sensor Power Supply, voltage less than normal |
| 0091 02 | J0091 02 | Throttle Demand Sensor, erratic or intermittent |
| 0091 03 | J0091 03 | Throttle Demand Sensor, open circuit or shorted high |
| 0091 04 | J0091 04 | Throttle Demand Sensor, shorted low |
| 0091 08 | J0091 08 | Throttle Demand Sensor, abnormal signal |
| 0091 12 | J0091-12 | Throttle Demand Sensor, power supply failure |
| 0100 03 | J0100 03 | Engine Oil Pressure Sensor, open circuit or shorted high |
| 0100 04 | J0100 04 | Engine Oil Pressure Sensor, shorted low |
| 0100 10 | | Engine Oil Pressure Sensor, power supply open circuit |
| 0102 03 | J0102 03 | Intake Manifold Pressure Sensor, open circuit or shorted high |
| 0102 04 | J0102 04 | Intake Manifold Pressure Sensor, shorted low |
| 0102 10 | | Intake Manifold Pressure Sensor, power supply open circuit |
| 0105 03 | J0105 03 | Intake Manifold Temperature Sensor, open circuit or shorted high |
| 0105 04 | J0105 04 | Intake Manifold Temperature Sensor, shorted low |
| 0110 03 | J0110 03 | Engine Coolant Temperature Sensor, open circuit or shorted high |
| 0110 04 | J0110 04 | Engine Coolant Temperature Sensor, shorted low |
| 0168 02 | J0168 02 | Battery Voltage, intermittent or incorrect |
| 0174 02 | J0174 02 | Fuel Temperature Sensor, erratic or intermittent |
| 0247 09 | J0639 09 | J1939 Datalink, abnormal update |
| 0253 02 | J0234 02 | Incorrect ECM Software |
| 0262 03 | J0620 03 | 5V Sensor Power Supply, voltage more than normal |
| 0262 04 | J0620 04 | 5V Sensor Power Supply, voltage less than normal |
| 0266 02 | | Crank without injection, switch state incorrect |
| 0267 02 | | External Stop Switch, data erratic or incorrect |
| 0320 02 | J0637 02 | Speed and Timing Sensor, intermittent loss of signal |
| 0320 11 | J0637 11 | Speed and Timing Sensor, loss of signal |
| 0321 02 | | Diagnostic Reset Switch, intermittent or incorrect |
| 0342 02 | J0723 02 | Speed and Timing Sensor No.2, intermittent signal |
| 0590 02 | | ECM identified missing timing pulse |
| 0774 02 | | Throttle Demand Sensor No.2, erratic or intermittent |
| 0774 03 | | Throttle Demand Sensor No.2, open circuit or shorted high |
| 0774 04 | | Throttle Demand Sensor No.2, shorted low |
| 0774 08 | | Throttle Demand Sensor No.2, abnormal signal |
| 0774 12 | | Throttle Demand Sensor No.2, power supply failure |
| 1627 03 | | Fuel Pump Relay, did not turn off |
| 1639 09 | | Machine Security System Module, abnormal update |
| 1684 00 | J1077 00 | Fuel Injection Pump, fuel temperature more than normal |

(continued)

(Table 3, contd)

| | | |
|------------|--------------|--|
| 1684 02 | J1077 02 | Fuel Injection Pump, software failure |
| 1684 03 | J1077 03 | Fuel Injection Pump, fuelling fault |
| 1684 04 | J1077 04 | Fuel Injection Pump, supply voltage fault |
| 1684 05 | J1077 05 | Fuel Injection Pump, invalid pulse width |
| 1684 07 | J1077 07 | Fuel Injection Pump, mechanical fault |
| 1684 08 | J1077 08 | Fuel Injection Pump, crankshaft reference fault |
| 1684 09 | J1077 09 | Fuel Injection Pump, CAN fault |
| 1684 10 | J1077 10 | Fuel Injection Pump, fuel shutoff signal error |
| 1684 11 | J1077 11 | Fuel Injection Pump, internal sensor fault |
| 1684 12 | J1077 12 | Fuel Injection Pump, device failure |
| 1684 14 | J1077 14 | Fuel Injection Pump, no communications |
| 1690 08 | | Analogue Speed Control, signal abnormal |
| 1743 02 | | Engine Mode Selection Switch State, invalid state |
| 1894 02 | | Set Speed Control Disengage Switch, invalid state |
| 1895 02 | | Set Speed Control Speed Toggle Switch, invalid state |
| Event Code | CID FMI Code | |
| E015 | 110 16 | High Engine Coolant Temperature Derate |
| E016 | 110 00 | High Engine Coolant Temperature Shutdown |
| E017 | 110 15 | High Engine Coolant Temperature Warning |
| E025 | 105 16 | High Intake Air Temperature Derate |
| E027 | 105 15 | High Intake Air Temperature Warning |
| E039 | 100 18 | Low Engine Oil Pressure Derate |
| E040 | 100 01 | Low Engine Oil Pressure Shutdown |
| E054 | 174 16 | High Fuel Temperature Derate |
| E056 | 174 15 | High Fuel Temperature Warning |
| E100 | 100 17 | Low Engine Oil Pressure Warning |
| E190 | 190 15 | Engine Overspeed Warning |
| E442 | | Engine Failed To Stop With A No-Fuel Command |
| E883 | | Engine Failed To Stop When Fuel Solenoid Disengaged |

i01878735

Indicator Lamps

Some engine applications are equipped with Indicator Lamps. Indicator lamps can be used as a diagnostic aid. There are two lamps. One lamp has an orange lens and the other lamp has a red lens.

These indicator lamps can be used in two ways:

- The indicator lamps can be used to identify the current operational status of the engine. The indicator lamps can also be used to indicate that the engine has a fault. This system is automatically operated via the ignition switch.
- The indicator lamps can be used to identify active diagnostic codes. This system is activated by pressing the Flash Code button.

Use the lamps to check the engine's operational status or the existence of any engine faults.

Each lamp will be illuminated in a combination of ways in order to identify the engine's operational status. The lamps will also be illuminated in a combination of ways to indicate if the engine has a fault. These combinations of illuminated lamps have the following meanings:

The status of the lamps before the engine is cranked. This also acts as a lamp check.

When the ignition switch is turned ON, the lamps will be illuminated for 2 seconds. The lamps are then OFF unless the cold starting aid is required.

Table 4

| Orange lamp (status) | Red lamp (status) | Comments |
|------------------------|-------------------|---|
| ON | ON | The lamps will be illuminated for 2 seconds or the lamps will be illuminated until the engine is cranked. |
| Refer to the comments. | OFF | The lamp will be OFF unless the cold starting aid is required. |

The lamp status with the cold starting aid in operation and before the engine is cranked.

The orange lamp will be illuminated until the engine is ready to be cranked.

Table 5

| Orange lamp (status) | Red lamp (status) | Comments |
|----------------------|-------------------|--|
| ON | OFF | The status of the lamps with the cold starting aid still operating. |
| Then OFF | OFF | This is the status of the lamps while the engine is being cranked. The cold starting aid is no longer operating. |

This is the status of the lamps while the engine is being cranked.

Unless there is a fault, the engine monitoring system will not illuminate the indicator lamps while the engine is being cranked. For example if there is a lack of lubricating oil pressure after the start delay is exceeded. This type of fault will cause the stop lamp for the engine to be illuminated.

Table 6

| Orange lamp (status) | Red lamp (status) | Comments |
|----------------------|-------------------|--|
| OFF | OFF | There are no apparent problems. |
| ON | ON | The lubricating oil pressure is low. This low oil pressure was measured after the set delay had expired. |

The status of the lamps after cranking has failed to start the engine.

Table 7

| Orange lamp (status) | Red lamp (status) | Comments |
|----------------------|-------------------|---|
| OFF | OFF | No faults were detected. |
| ON | OFF | An electrical fault was detected. |
| OFF | Flashing | The engine was activated when a serious fault was detected. |

Other combinations of illuminated indicator lamp

The following combinations of lamp status may also be exhibited when the engine is either running or when the engine has been shut down automatically.

Table 8

| Orange lamp (status) | Red lamp (status) | Comments |
|----------------------|-------------------|--|
| OFF | OFF | No faults were detected. |
| OFF | ON | The oil pressure is low. |
| Flashing | OFF | Either the coolant temperature is high or the intake air temperature is high. The engine may be derated. |
| OFF | Flashing | Either a fault has caused the engine to be automatically shut down or the engine has exceeded the condition for a derate. |
| ON | OFF | An electrical fault has been detected. |
| ON | ON | The oil pressure is low and there is an electrical fault. |
| ON | Flashing | Either a fault has caused the engine to shut down or the engine has exceeded the conditions for a derate. There is also an electrical fault. |
| Flashing | ON | The oil pressure is low and either the coolant temperature or the intake air temperature is high. The engine may be derated. |

Use the lamps to identify active diagnostic codes.

The indicator lamps can be used to identify an active code by flashing in a sequence that will identify the active code. The active code that is flashed by the indicator lamps is only the component identifier (CID). The indicator lamps cannot identify the fault with the component. The active code that is flashed by the indicator lamps is not a Failure Mode Identifier (FMI).

Table 9

| CID number | Description | Flash code |
|------------|---|------------|
| 0041 | 8 Volt Power Supply | 517 |
| 0091 | Throttle Position Sensor | 154 |
| 0100 | Engine Oil Pressure Sensor | 157 |
| 0102 | Intake Manifold Pressure Sensor | 135 |
| 0105 | Intake Manifold Air Temperature Sensor | 133 |
| 0110 | Engine Coolant Temperature Sensor | 168 |
| 0174 | Fuel Temperature Sensor | 165 |
| 0247 | J1939 Data Link | 514 |
| 0253 | Personality Module | 416 |
| 0262 | 5 Volt Power Supply | 516 |
| 0320 | Engine Speed/Timing Sensor | 141 |
| 0342 | Secondary Engine Speed Sensor | 142 |
| 0774 | Secondary Throttle Position Sensor | 155 |
| 1684 | Fuel Injection Pump | 158 |
| 1743 | Mode Selector Switch for Engine Operation | 144 |
| 1894 | Cruise Control Status Switch | 427 |
| 1895 | Toggle Switch for Cruise Control Speed | 428 |

When the Flash Code feature is activated the indicator lamps will flash the codes of all active codes. Activation of the indicator lamps is achieved by cycling the keyswitch OFF and ON twice within 3 seconds.

There will be a delay of 2 seconds before the lamps start to flash the identity of any active code.

An active CID with two digits will be flashed in the following sequence. There will be a number of flashes. The number of flashes will equal the first digit. There will be a delay before a second number of flashes. The second number of flashes will equal the second digit. For example, a CID code of 41 will be four flashes, a delay and the one flash. A three digit CID code will have two delays between the sequence of flashes. A four digit CID code will have three delays between the sequence of flashes.

Each flash of the lamp will be 0.5 seconds long.

There will be a delay between each flash of 0.3 seconds.

Each delay between each digit of the code will be 2 seconds.

After one active code has been identified there will be a delay of 5 seconds before the next active code is flashed.

The sequence of flashing the active codes may be restarted at any time by reactivating the cycling of the keyswitch.

i01798103

Replacing the ECM

NOTICE

Keep all parts clean from contaminants.

Contaminants may cause rapid wear and shortened component life.

The engine is equipped with an Electronic Control Module (ECM). The ECM contains no moving parts. Follow the troubleshooting procedures in this manual in order to be sure that replacing the ECM will correct the problem. Verify that the suspect ECM is the cause of the problem.

Note: Ensure that the ECM is receiving power and that the ECM is properly grounded before replacement of the ECM is attempted. Refer to Troubleshooting, “Electrical Power Supply Circuit - Test”.

A test ECM can be used in order to determine if the ECM on the engine is faulty. Install a test ECM in place of the suspect ECM. Flash the personality module into the test ECM. Program the parameters for the test ECM. The parameters must match the parameters in the suspect ECM. Refer to the following test steps for details. If the test ECM resolves the problem, reconnect the suspect ECM. Verify that the problem returns. If the problem returns, replace the ECM.

Use the electronic service tool to read the parameters in the suspect ECM. Record the parameters in the suspect ECM. The personality module can be flashed into the new ECM. After the ECM is installed on the engine, the parameters must be programmed into the new ECM.

Note: When a new ECM is not available, you may need to remove an ECM from an engine that is not in service. The ECM must have the same serial number suffix. Ensure that the replacement ECM and the Personality Module Interlock Code match the suspect ECM. Be sure to record the parameters from the replacement ECM. Use the “Copy Configuration ECM Replacement” function in the electronic service tool.

NOTICE

If the Personality Module and engine application are not matched, engine damage may result.

Perform the following procedure in order to replace the ECM.

1. Connect the electronic service tool to the service tool connector.
2. Use the “Copy Configuration ECM Replacement” function from the electronic service tool. If the “Copy Configuration” is successful, proceed to Step 4. If the “Copy Configuration” failed, proceed to Step 3.

Note: You may want to record any Logged Faults and Events for your records.

3. Record the parameters. Record all of the parameters on the “Main Configuration” screen. Also, record all of the parameters on the “Throttle Configuration” screen and on the “Mode Configuration” screen.

Note: If the parameters cannot be read, the parameters must be obtained elsewhere. Some parameters are stamped on the engine information plate, but most parameters must be obtained from the factory.

4. Remove the ECM.
 - a. Turn the keyswitch to the OFF position.
 - b. Turn the battery disconnect switch to the OFF position.
 - c. Slacken the 4 mm Allen head screw and disconnect the ECM 70-pin (P1/J1) connectors.
 - d. Remove the mounting bolts from the ECM.
 - e. Disconnect the grounding strap from the ECM.
5. Install the replacement ECM.
 - a. Use the old mounting hardware to install the replacement ECM. The mounting hardware should be free of damage.

- b. Check that the ECM mounting hardware is installed correctly. The rubber grommets are used to protect the ECM from excessive vibration. The ECM should be able to drift in the rubber grommets.
 - c. Install the ground strap for the ECM on the engine.
 - d. Reconnect the J1/P1 70 Pin connector to the ECM. Tighten the Allen head screw on the connectors to a torque of 6 N·m (55 lb in).
6. Download the Flash file.
 - a. Connect the electronic service tool to the service connector.
 - b. Select “WinFlash” from the “Utilities” menu of the electronic service tool.
 - c. Select the appropriate file.
7. If it is necessary, use the electronic service tool to clear the rating interlock in the Personality Module. To clear the rating interlock, enter the factory password when the electronic service tool is first connected. Activating the “Test ECM” mode will also clear the rating interlock.
8. Use the electronic service tool to program the parameters. Perform the following procedure.
 - a. If the “Copy Configuration” procedure was successful, use the “Copy Configuration, ECM Replacement” function to load the configuration file into the ECM.
 - b. If the “Copy Configuration” procedure failed, configure the parameters individually. The parameters should match the parameters from step 2.
9. Check for logged diagnostic codes. Factory passwords are required to clear Logged Events.

i01798104

Self-Diagnostics

The Electronic Control Module (ECM) has the ability to detect problems with the electronic system and with engine operation. When a problem is detected, a code is generated. An alarm may also be generated. There are two types of codes:

- Diagnostic
- Event

Diagnostic Code – When a problem with the electronic system is detected, the ECM generates a diagnostic code. This indicates the specific problem with the circuitry.

Diagnostic codes can have two different states:

- Active
- Logged

Active Code – An active diagnostic code indicates that an active problem has been detected. Active codes require immediate attention. Always service active codes prior to servicing logged codes.

Logged Code – Every generated code is stored in the permanent memory of the ECM. The codes are logged.

Event Code – An event code is generated by the detection of an abnormal engine operating condition. For example, an event code will be generated if the oil pressure is too low. In this case, the event code indicates the symptom of a problem.

Logged codes may not indicate that a repair is needed. The problem may have been temporary. The problem may have been resolved since the logging of the code. If the system is powered, it is possible to generate an active diagnostic code whenever a component is disconnected. When the component is reconnected, the code is no longer active. Logged codes may be useful to help troubleshoot intermittent problems. Logged codes can also be used to review the performance of the engine and the electronic system.

i01798105

Sensors and Electrical Connectors

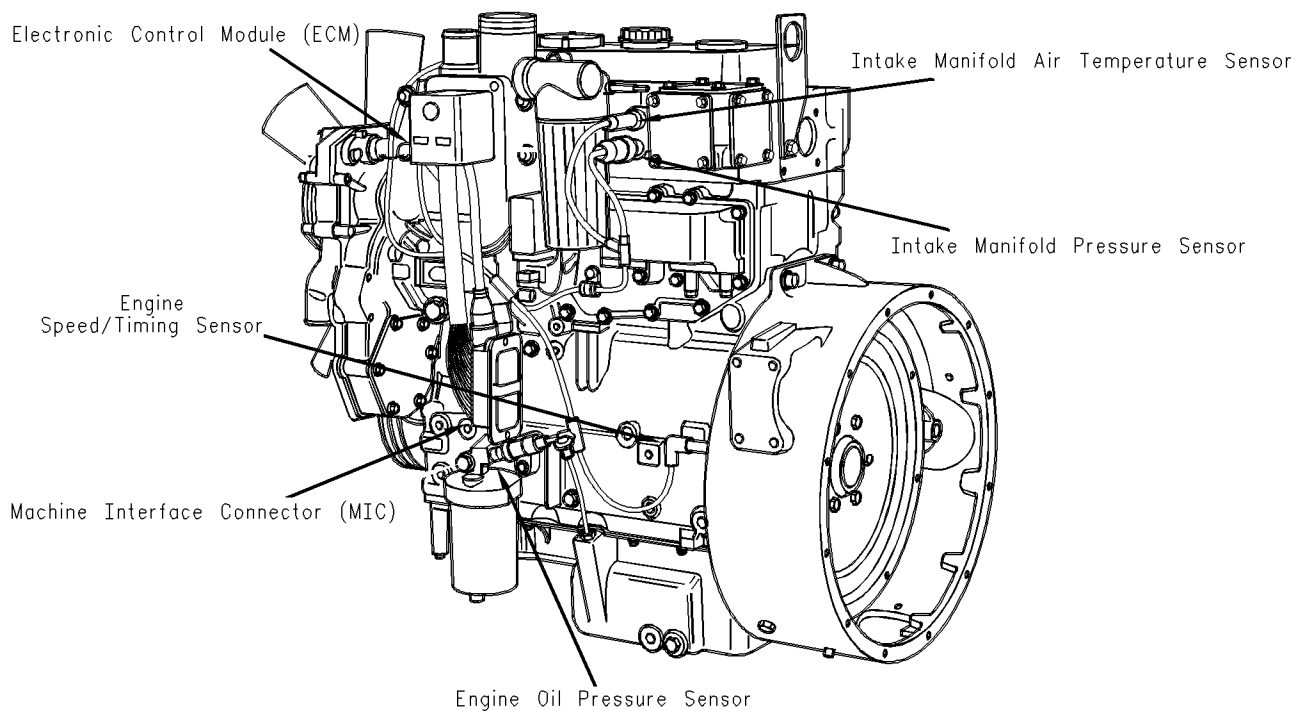

Illustration 5

1104

Typical example of left side sensor locations

g00954205

Voltage Load Protection Module
VLPM

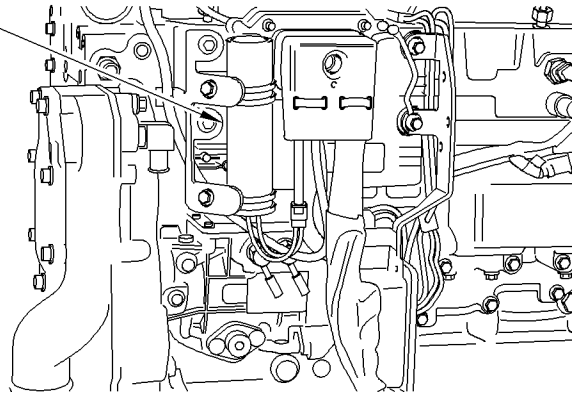

Illustration 6
1104 engine
Typical location of the VLPM

g00915379

Engine Coolant Temperature Sensor

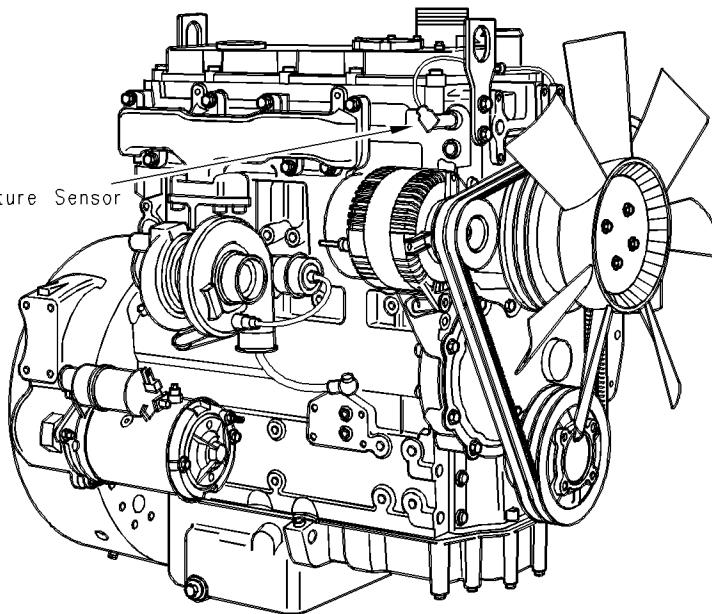

Illustration 7
1104
Typical example of right side sensor locations

g00882117

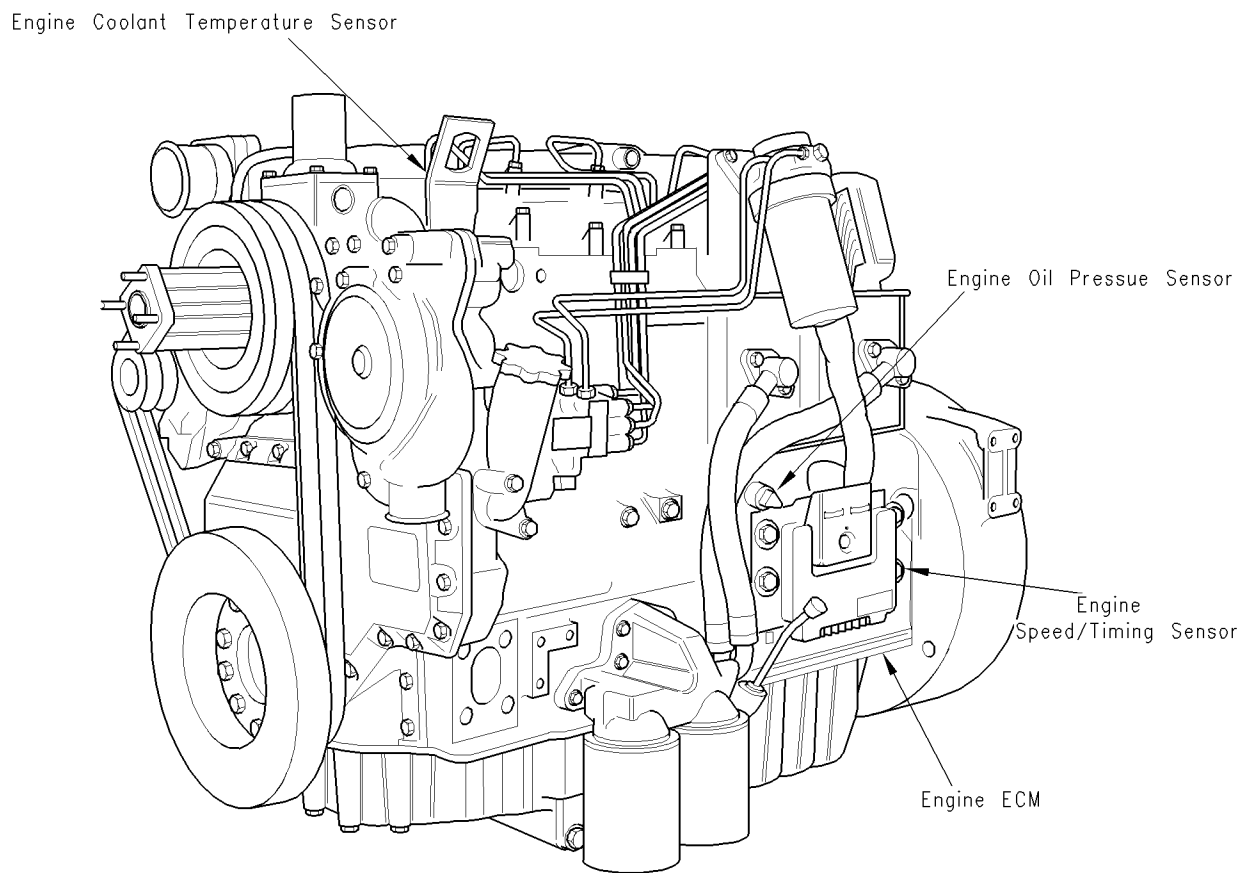

Illustration 8

1106

Typical example of left side sensor locations

g00884570

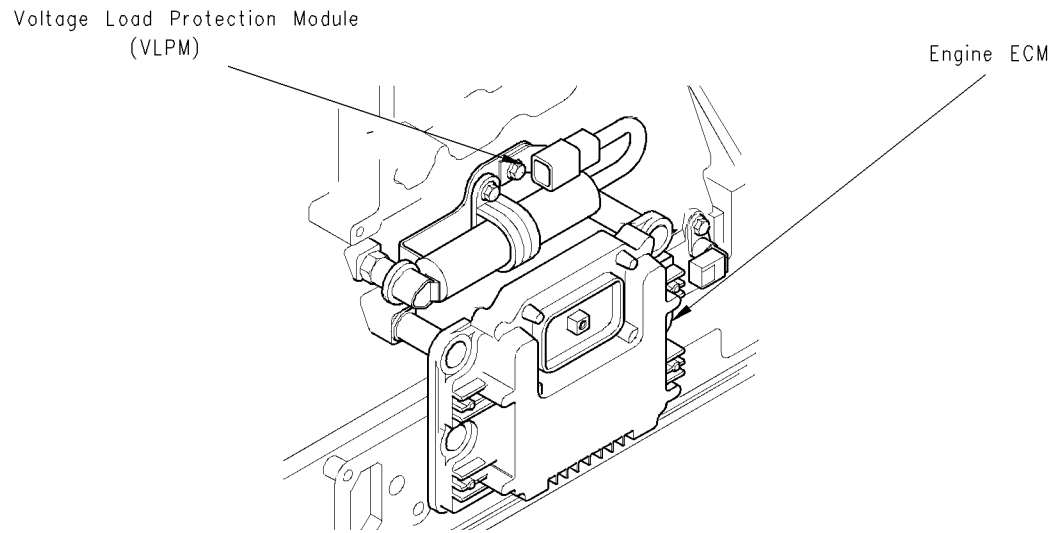

Illustration 9
1106 engine
Typical location of the VLPM

g00908929

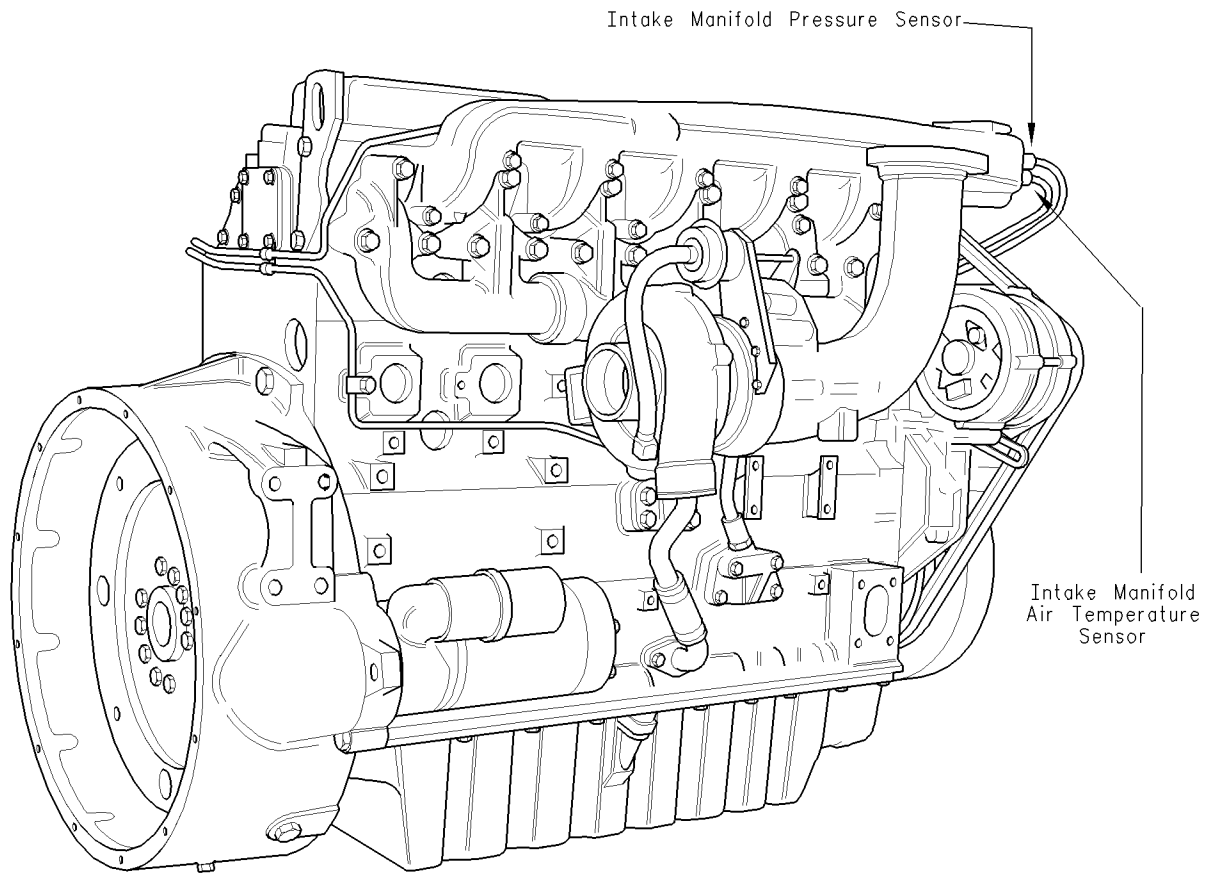

Illustration 10
Typical example of right side sensor locations
1106

g00954214

Table 10

| Connector | Function |
|-----------|--|
| J1/P1 | ECM Connector 70 Pin Machine Harness |
| J20/P20 | Machine Interface Connector (70-Pin Engine Harness) |
| J40/P40 | Fuel Injection Pump (3-Pin Connector) |
| J100/P100 | Engine Coolant Temperature Sensor (2-Pin Connector) |
| J103/P103 | Intake Manifold Air Temperature Sensor (2-Pin Connector) |
| J200/P200 | Intake Manifold Pressure Sensor (3-Pin Connector) |
| J201/P201 | Engine Oil Pressure Sensor (3-Pin Connector) |
| J401/P401 | Speed/Timing Sensor (2-Pin Connector) |

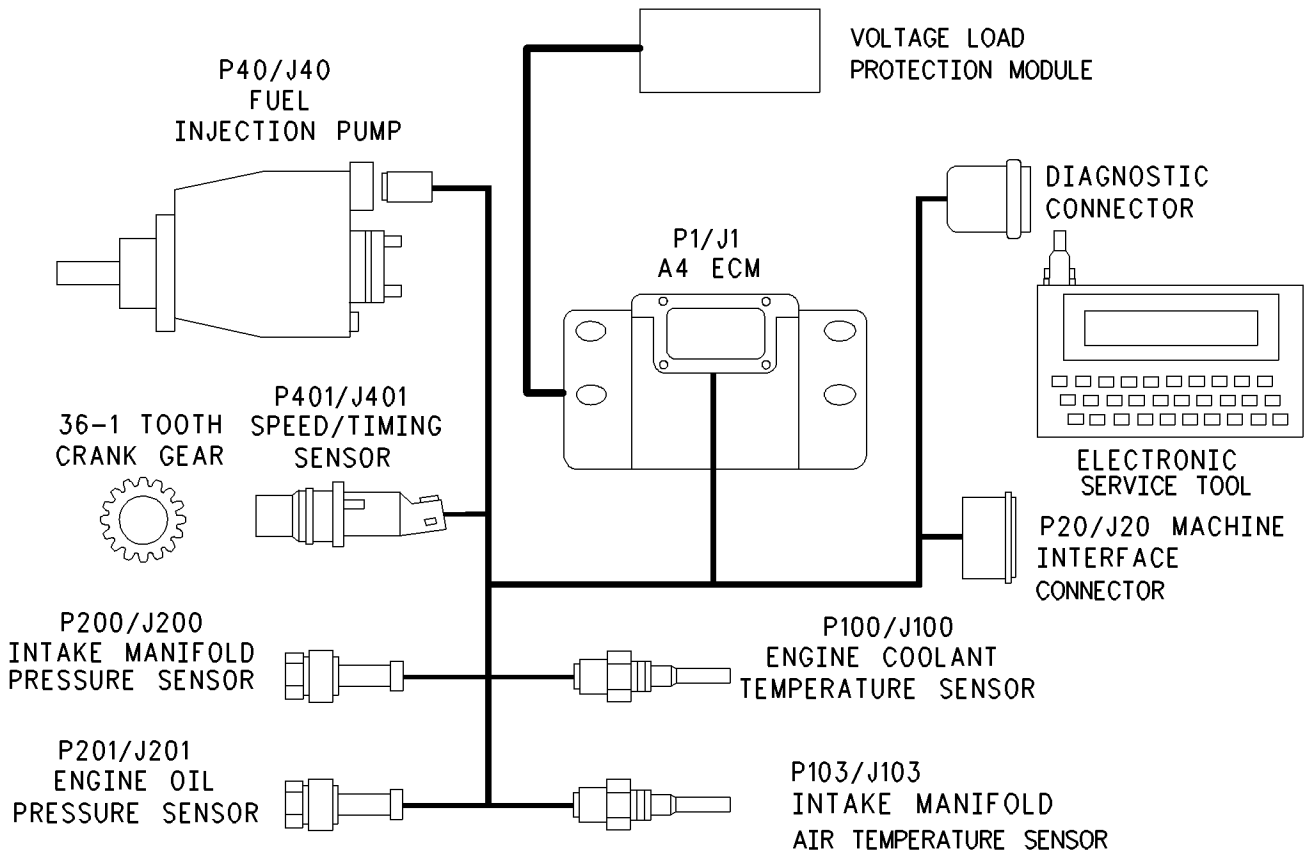

Illustration 11
Basic engine schematic

i02294251

Engine Wiring Information

The wiring diagrams are revised periodically. The wiring diagrams will change with updates to the wiring harness. For the most current information, always check the revision number of the diagram. Use the diagram with the latest revision number.

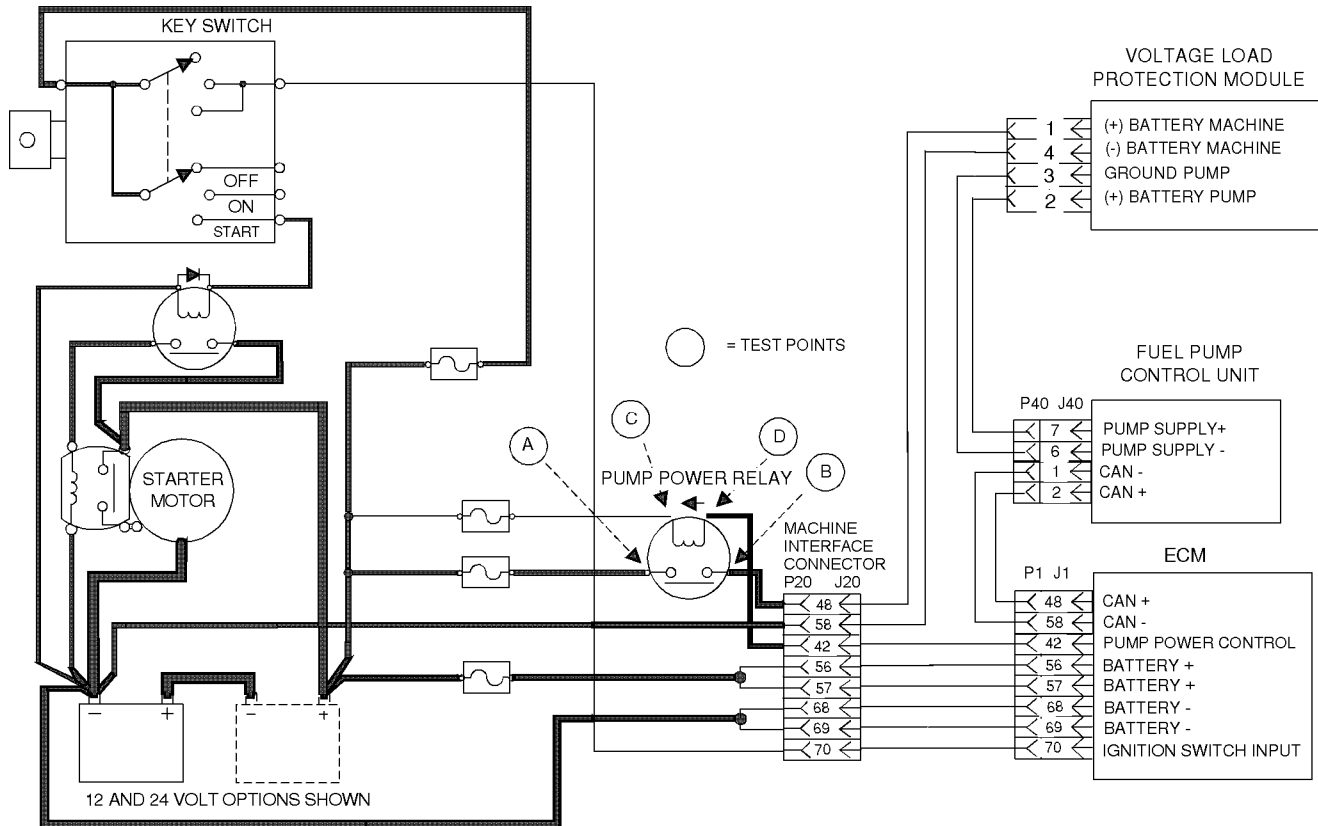

Illustration 12

g01152042

Schematic for the fuel injection pump and ECM power supply for engines with a Machine Interface Connector that has 70 pins

Note: Each terminal end of the J1939 CAN data link must be connected with a 120 ohm terminating resistor.

Note: Digital outputs 7,8,9,10,11,12,13, and 14 are only suitable for a 12 V system.

Note: Some engines with a Machine Interface Connector that has 70 pins do not have the following wiring connections: 35, 50, 53, 54, 60, 62, 63, 64, and 67.

Machine Interface Connector

Two types of Machine Interface Connector are available. One type of connector has 70 pins and the other type has 31 pins. Illustration 13 and illustration 14 show the layout for the Machine Interface Connector with 70 pins. Illustration 15 and illustration 16 show the layout for the Machine Interface Connector with 31 pins.

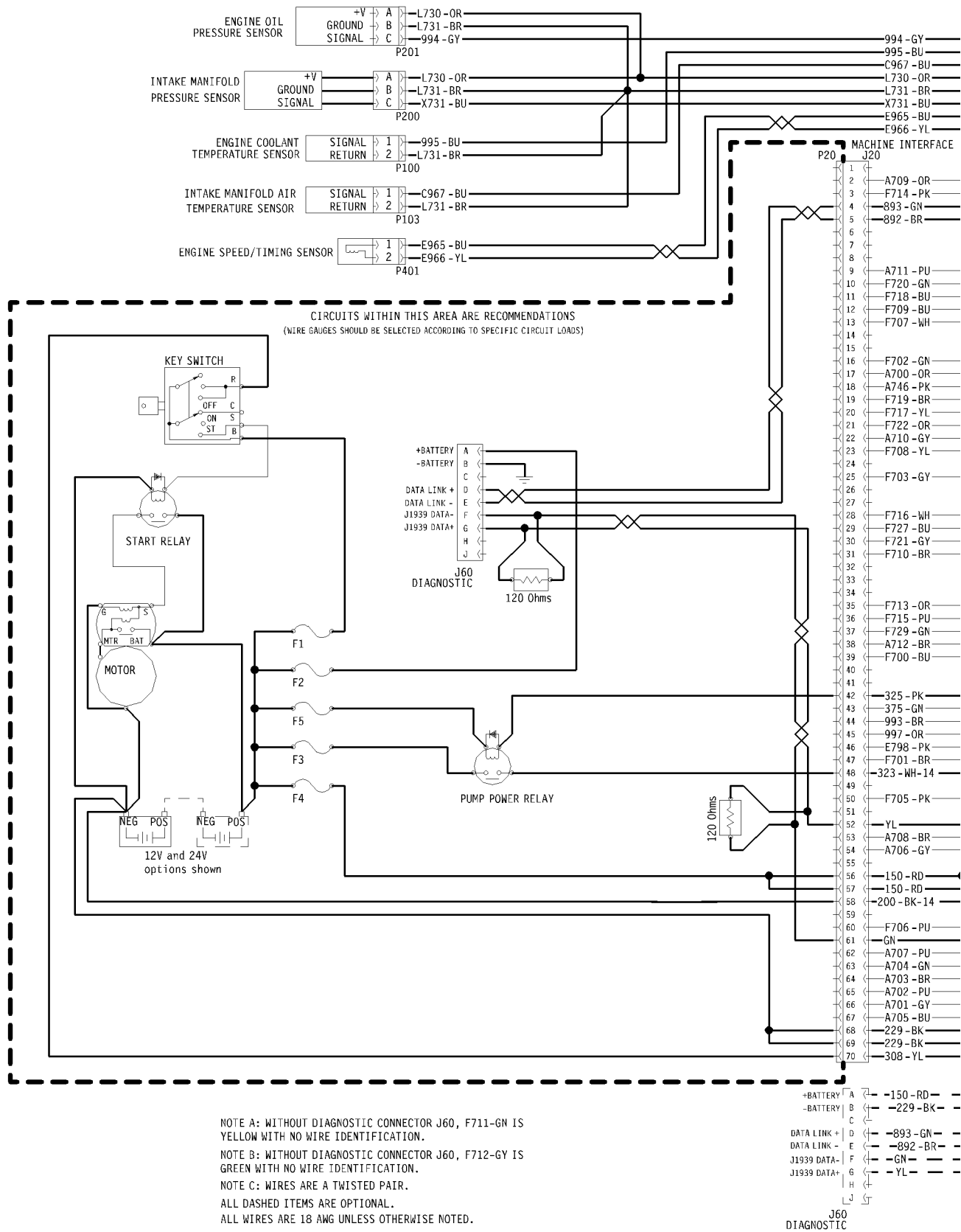

Illustration 13

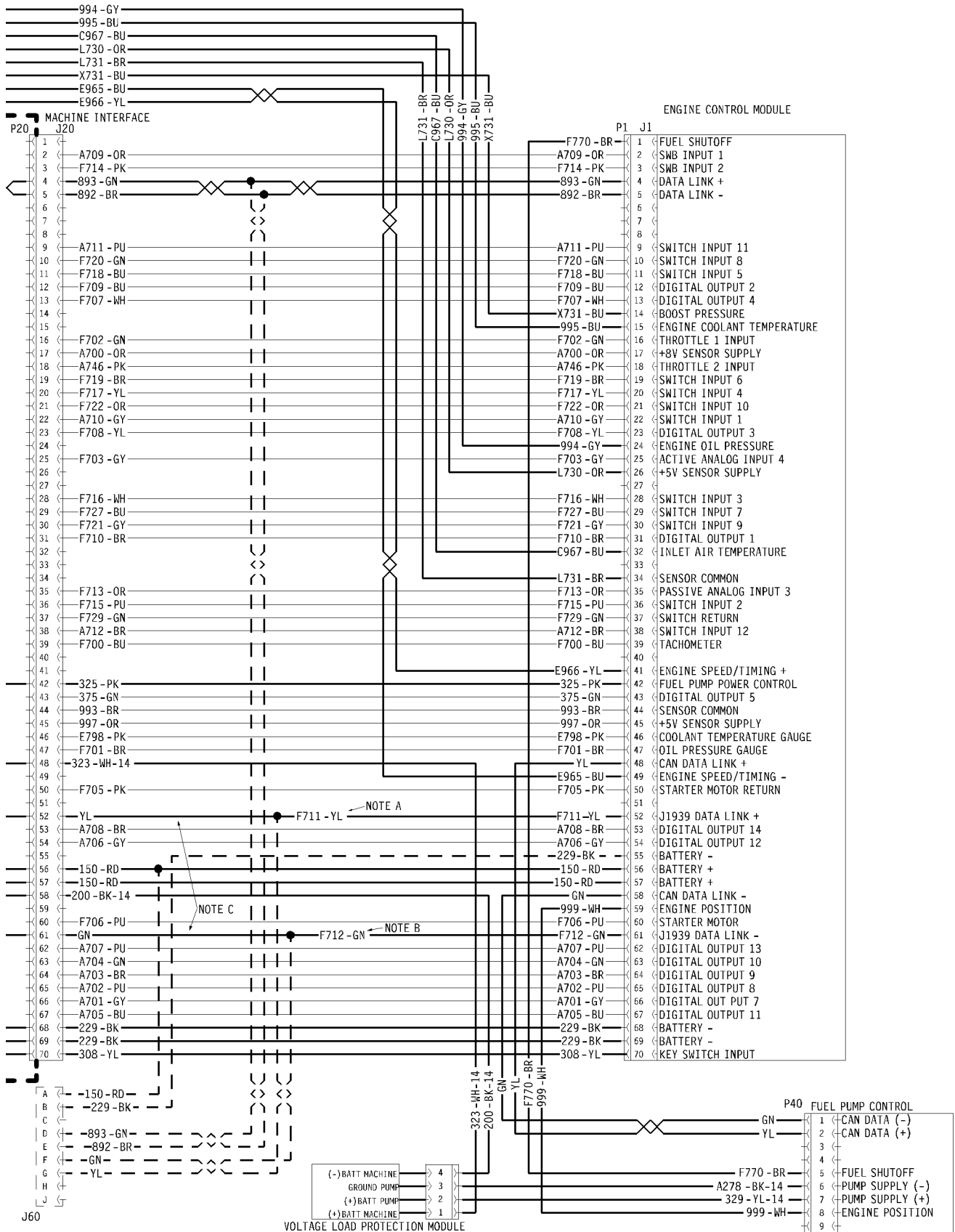
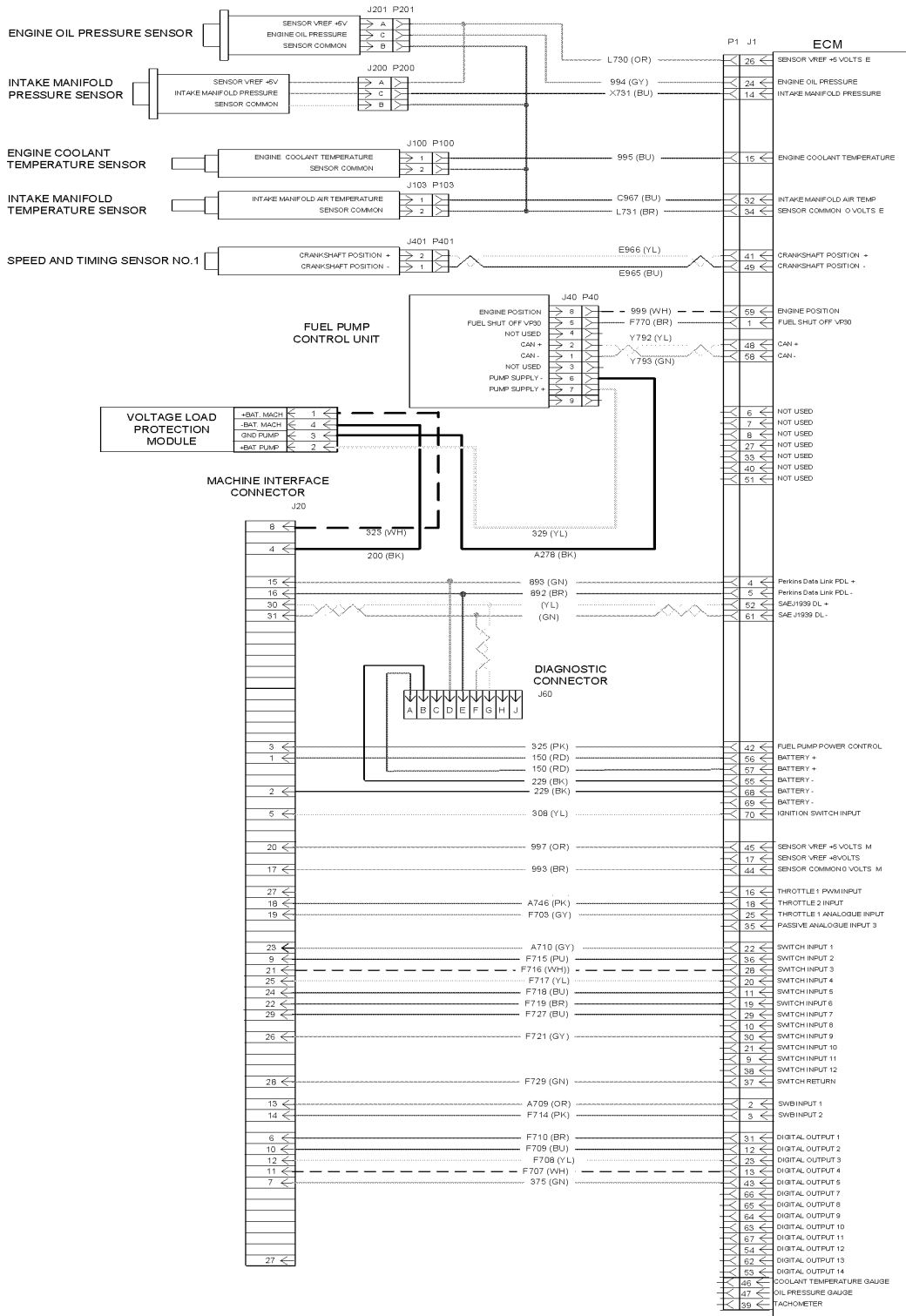

Illustration 14

**1100 SERIES
ENGINE HARNESS WIRING DIAGRAM
(A4E1 CONTROLLER - With Diagnostic)**



- NOTES**
- 1) Wire sizing:
14 AWG (approx. 2mm²)
18 AWG (approx. 0.8mm²)
 - 2) Each end of the machine J1939 data link must be terminated with a 120 ohm resistor.
 - 3) Wires are identified by the 4 digit number shown on diagram and by colour.
 - 4) Digital outputs 7,8,9,10,11,12,13 and 14 are only suitable for 12V operation. Do not use on 24V systems.
 - 5) Twisted Pair to SAE J1939-15
 - 6) Twisted Pair

COLOUR CHART

| |
|-------------|
| RED (RD) |
| BLACK (BK) |
| GREEN (GN) |
| BLUE (BU) |
| PURPLE (PU) |
| PINK (PK) |
| ORANGE (OR) |
| BROWN (BR) |
| GREY (GY) |
| WHITE (WH) |
| YELLOW (YL) |

**1100 SERIES
ENGINE HARNESS WIRING DIAGRAM
(A4E1 CONTROLLER - No Diagnostic)**

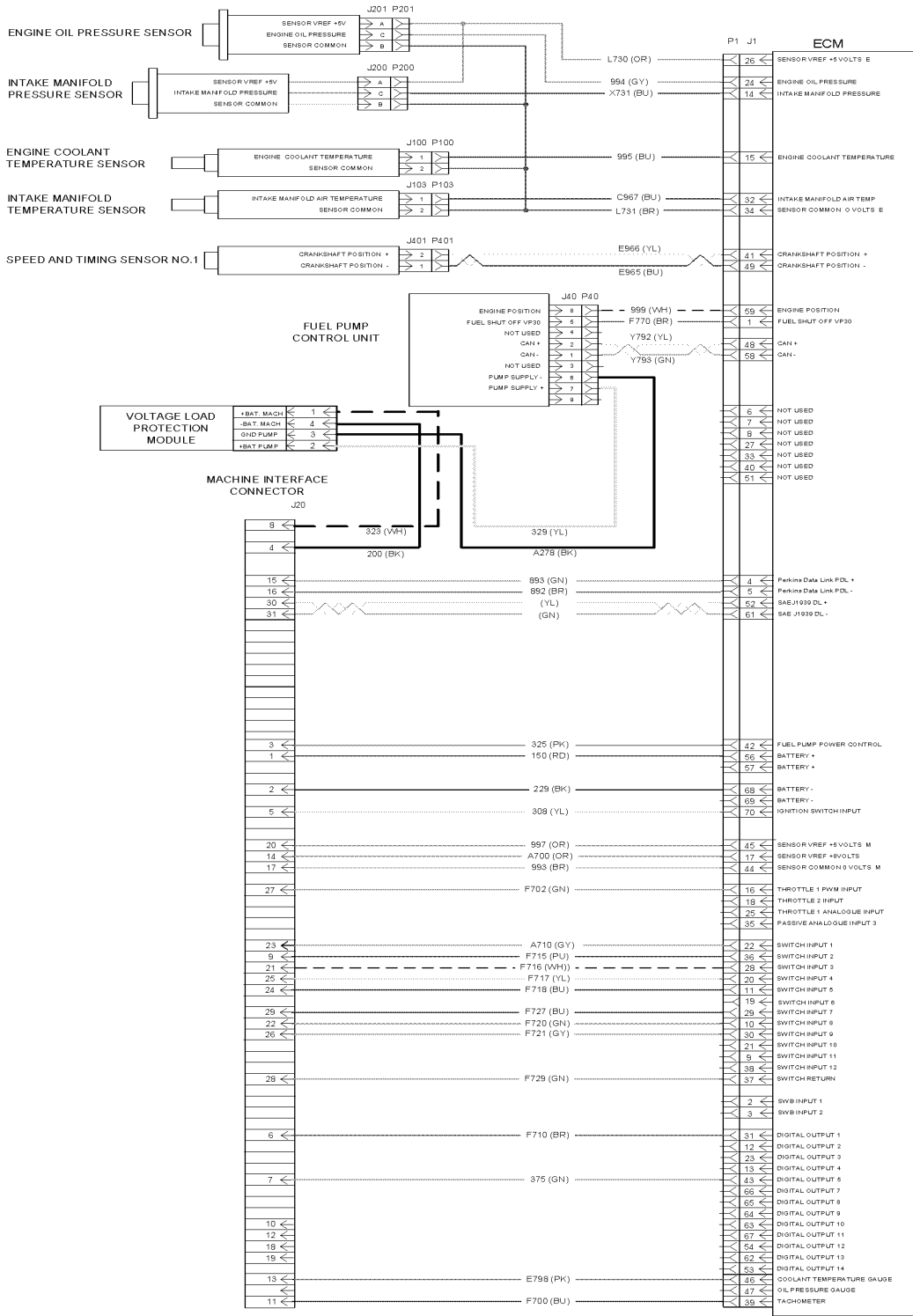

- NOTES**
- 1) Wire sizing:
14 AWG (approx. 2mm²) ———
18 AWG (approx. 0.8mm²) - - - - -
 - 2) Each end of the machine J1939 data link must be terminated with a 120 ohm resistor.
 - 3) Wires are identified by the 4 digit number shown on diagram and by colour.
 - 4) Digital outputs 7,8,9,10,11,12,13 and 14 are only suitable for 12V operation. Do not use on 24V systems.
 - 5) Twisted Pair to SAE J1939-15
Twisted Pair
 - 6) J = Jack P = Plug

COLOUR CHART

| | |
|------------|-------------|
| — (Red) | RED (RD) |
| — (Black) | BLACK (BK) |
| — (Green) | GREEN (GN) |
| — (Blue) | BLUE (BU) |
| — (Purple) | PURPLE (PU) |
| — (Pink) | PINK (PK) |
| — (Orange) | ORANGE (OR) |
| — (Brown) | BROWN (BR) |
| — (Grey) | GREY (GY) |
| — (White) | WHITE (VH) |
| — (Yellow) | YELLOW (YL) |

The procedures in this manual refer to the connector that has 70 pins. Table 11 shows the conversion from engine models that have a connector with 70 pins to engine models that have a connector with 31 pins.

Table 11

| Machine Interface Connector Pin Numbers | |
|---|--------|
| 70 Pin | 31 Pin |
| 2 | 13 |
| 3 | 14 |
| 4 | 15 |
| 5 | 16 |
| 11 | 24 |
| 12 | 10 |
| 13 | 11 |
| 16* | 27* |
| 18 | 18 |
| 19 | 22 |
| 20 | 25 |
| 22 | 23 |
| 23 | 12 |
| 25 | 19 |
| 28 | 21 |
| 29 | 29 |
| 30 | 26 |
| 31 | 6 |
| 36 | 9 |
| 37 | 28 |
| 42 | 3 |
| 43 | 7 |
| 44 | 17 |
| 45 | 20 |
| 48 | 8 |
| 52 | 30 |
| 56 | 1 |
| 58 | 4 |
| 61 | 31 |
| 68 | 2 |
| 69* | 1* |
| 70 | 5 |
| * These connections are not used on some engine models. | |

Harness Wire Identification

Perkins identifies all wires with eleven solid colors. The circuit number is stamped on the wire at a 25 mm (1 inch) spacing. Table 12 lists the wire colors and the color codes.

Table 12

| Color Codes for the Harness Wire | | | |
|----------------------------------|--------|------------|--------|
| Color Code | Color | Color Code | Color |
| BK | Black | GN | Green |
| BR | Brown | BU | Blue |
| RD | Red | PU | Purple |
| OR | Orange | GY | Gray |
| YL | Yellow | WH | White |
| | | PK | Pink |

For example, a wire identification of F702-GN on the schematic would signify a green wire with the circuit number F702. F702-GN identifies the power supply for the 8 V throttle sensor.

Note: Always replace a harness wire with the same gauge of wire and with the same color code.

Programming Parameters

i01798107

Programming Parameters

The electronic service tool can be used to view certain parameters that can affect the operation of the engine. The electronic service tool can also be used to change certain parameters. The parameters are stored in the Electronic Control Module (ECM). Some of the parameters are protected from unauthorized changes by passwords. Parameters that can be changed have a tattletale number. The tattletale number shows if a parameter has been changed.

i01798108

Factory Passwords

Passwords

Passwords are part of a security system that helps to prevent unauthorized reprogramming of certain parameters. Passwords prevent unauthorized erasing of logged events. Passwords allow the factory to control access to engine calibration parameters. Passwords allow the customer to control access to certain programmable engine parameters.

Factory Passwords

Factory passwords are required to clear any event code. Factory passwords are required to change certain parameters such as Full Load Setting. The factory passwords restrict changes to authorized personnel. When the correct factory passwords have been entered, the changes can then be made.

In order to obtain the proper factory passwords, certain information must be given to an authorized Perkins distributor. Since the factory passwords contain alphabetic characters, the electronic service tool can be used to perform this function. In order to obtain the factory passwords, proceed as if you already have the factory passwords. At some point, if the factory passwords are actually needed, the electronic service tool will request the factory passwords and the electronic service tool will display the information that is required to obtain the factory passwords.

Note: The old interlock code is required to change the interlock code on a used ECM. A new interlock code is also required to change the interlock code on a used ECM.

The electronic service tool screen for factory passwords will display the following parameters:

- Serial number of the Electronic Control Module (ECM)
- Engine serial number
- Serial number for the electronic service tool
- Reason Code
- Total Tattletale number

Note: The factory passwords may only be used for one programming session. A different set of factory passwords will be required after you exit the electronic service tool screen. A different set of passwords will be required to change information on another electronic service tool screen.

Customer Passwords

Customer Passwords allow the customer to restrict access to parameters that are programmable by the customer. The customer passwords cannot be longer than eight characters. The customer has the option of entering one or two customer passwords.

Note: If the owner loses the owner's customer passwords, the owner will not be able to program parameters that are protected by customer passwords. By using factory passwords, one can read customer passwords. Then use those customer passwords to program parameters that have been protected by customer passwords.

i01798110

Flash Programming

Flash Programming – This is a method of programming or updating the personality module in an ECM.

The electronic service tool can be utilized to flash a new personality module into the ECM. The flash is accomplished by transferring the data from a PC to the ECM.

Flash Programming a Personality Module

1. Connect the electronic service tool to the service tool connector.
2. Select “WinFlash” from the “Utilities” menu on the electronic service tool.

“WinFlash” will try to detect an ECM.

3. When an ECM has been detected, the “ECM Selector” window will appear. Select the appropriate ECM that needs to be flashed and press “Browse”.

The “Flash File Selection” window will appear.

4. The flash files are located on a disk drive and in a directory. Select the correct disk drive and the correct directory from “Drives” and “Directories” on the electronic service tool.

A list of flash files will appear.

5. Select the correct file from the list of flash files. Read the “File Info” and the “Description” in order to verify that the correct file is selected. Select “OK”.
6. Select the “Begin Flash” button in order to program the personality module.

When the flash is completed, this message will appear: “Flash Completed Successfully”.

7. Start the engine and check for proper operation.
 - a. If a diagnostic code of 253-02 Incorrect ECM Software is generated, program any parameters that were not in the old personality module.
 - b. Access the “Configuration” screen under the “Service” menu in order to determine the parameters that require programming. Look under the “Tattletale” column. All of the parameters should have a tattletale of 1 or more. If a parameter has a tattletale of 0, program that parameter.

“WinFlash” Error Messages

If you receive any error messages during flash programming, click on the “Cancel” button in order to stop the process. Access the information about the “ECM Summary” under the “Information” menu. Make sure that you are flashing the correct file for your engine.

System Configuration Parameters

i01798111

System Configuration Parameters

System Configuration Parameters affect the emissions of the engine or the power of the engine. System configuration parameters are programmed at the factory. Normally, system configuration parameters would never need to be changed through the life of the engine. System configuration parameters must be reprogrammed if an ECM is replaced. Unless the engine rating has changed, system configuration parameters do not need to be reprogrammed when the Personality Module is replaced. The correct values for these parameters are stamped on the engine information ratings plate. The engine information ratings plate is located on the valve cover or on the air intake manifold. Factory passwords are required to change these parameters. The following information is a description of the system configuration parameters.

“Full Load Setting”

“Full Load Setting” is a number that represents the adjustment to the fuel system that was made at the factory in order to fine tune the fuel system. The correct value for this parameter is stamped on the engine information ratings plate. If the ECM is replaced, the “full load setting” must be reprogrammed in order to prevent a 253-02 diagnostic code from becoming active.

“Full Torque Setting”

“Full Torque Setting” is similar to “Full Load Setting”. If the ECM is replaced, the full torque setting must be reprogrammed in order to prevent a 253-02 diagnostic code from becoming active.

Rating Interlock

The Rating Interlock is a code that prevents the use of an incorrect power rating and/or emission rating for a specific engine. Each horsepower rating and each emission certification has a different code to all other horsepower ratings and emission certifications.

When an ECM is replaced this rating interlock code must match the code that is stored in the ECM. If the rating interlock code does not match the code that is stored in the ECM, both of the following situations will exist:

- The engine will not run.
- The diagnostic code 253-02 (Incorrect ECM Software) will be active.

Note: The flash programming of a new rating interlock replaces the old rating interlock.

This code does not need to be programmed when the replacement ECM is from the same engine rating.

If the ECM is from a different engine rating, then the following components may need to be changed: pistons, fuel injectors, and other components. The engine information ratings plate must also be changed in order to reflect the new rating.

Some vehicle systems such as the cooling system or the transmission may also require changes when the engine is rerated. Please contact the local OEM dealer for further information.

“Engine Serial Number”

When a new ECM is delivered, the engine serial number in the ECM is not programmed. The “Engine Serial Number” should be programmed to match the engine serial number that is stamped on the engine information plate.

“ECM Software Release Date”

This parameter is defined by the rating interlock and this parameter is not programmable. The “ECM Software Release Date” is used to provide the version of the software. The Customer parameters and the software change levels can be monitored by this date. The date is provided in the month and the year (NOV99). NOV is the month (November). 99 is the year (1999).

Troubleshooting without a Diagnostic Code

i01798098

Alternator Noise (Noisy Operation)

i01798099

Note: This is NOT an electronic system problem.

Refer to Testing and Adjusting for information on determining the cause of this condition.

Probable Causes

- Alternator drive belts
- Alternator drive pulley
- Alternator bearings

Recommended Actions

Alternator Drive Belts

1. Inspect the condition of the alternator drive belts. If the alternator drive belts are worn or damaged, replace the belts. Refer to Disassembly and Assembly, "Alternator - Remove" and Disassembly and Assembly, "Alternator - Install". Ensure that the alternator drive belts are in alignment. Inspect the alternator mounting bracket for cracks and wear. Repair the mounting bracket or replace the mounting bracket in order to ensure that the alternator drive belts and the alternator drive pulley are in alignment.
2. Check the tension on the alternator drive belts. Adjust the tension, if necessary. Refer to Testing and Adjusting, "V-Belt - Test".

Alternator Drive Pulley

Loosen the nut for the alternator drive pulley and tighten the nut to the correct torque. Refer to Specifications, "Alternator and Regulator" for the correct torque.

Alternator Bearings

Verify that there is excessive play of the shaft in the alternator and that the alternator bearings are worn. The alternator is a nonserviceable item. The alternator must be replaced if the bearings are worn. Refer to Disassembly and Assembly, "Alternator - Remove" and Disassembly and Assembly, "Alternator - Install".

Alternator Will Not Charge (Charging Problem)

Note: This is NOT an electronic system problem.

Probable Causes

- Alternator drive belts
- Charging circuit
- Regulator
- Alternator

Recommended Actions

Alternator Drive Belts

1. Inspect the condition of the alternator drive belts. If the alternator drive belts are worn or damaged, replace the belts. Refer to Disassembly and Assembly, "Alternator - Remove" and Disassembly and Assembly, "Alternator - Install".

Check the tension on the alternator drive belts. Adjust the belt tension if the tension is incorrect. Refer to Testing and Adjusting, "V-Belt - Test".

Charging Circuit

Inspect the battery cables, wiring, and connections in the charging circuit. Clean all connections and tighten all connections. Replace any faulty parts.

Alternator or Regulator

Verify that the alternator or the regulator is operating correctly. Refer to Testing and Adjusting, "Alternator - Test". The alternator is not a serviceable item. The alternator must be replaced if the alternator is not operating correctly.

i01798112

Battery

Note: This is NOT an electronic system problem.

Probable Causes

- Faulty battery
- Auxiliary device drains the battery current.

Recommended Actions

Faulty Battery

1. Verify that the battery is no longer able to hold a charge. Refer to Testing and Adjusting, "Battery - Test".
2. Replace the battery. Refer to Operation and Maintenance, "Battery - Replace".

Auxiliary Device

1. Verify that the auxiliary device drained the battery by being left in the ON position.
2. Charge the battery.
3. Verify that the battery is able to maintain a charge.

i01798113

Can Not Reach Top Engine RPM

Note: If this problem occurs only under load, refer to Troubleshooting, "Low Power/Poor or No Response to Throttle".

Probable Causes

- Refer to the logged codes.
- Fuel supply
- Air intake and exhaust system
- Individual malfunctioning cylinders
- Valve lash
- Low compression (cylinder pressure)
- Fuel injection nozzles
- Turbocharger (if equipped)
- ECM parameters
- Throttle signal from the throttle position sensor

Recommended Actions

Diagnostic Codes

Check for active diagnostic codes on the electronic service tool. Troubleshoot any active codes before continuing with this procedure.

Fuel Supply

1. Check the fuel pressure. Refer to Systems Operation, Testing and Adjusting, "Fuel System Pressure - Test".
2. Ensure that the fuel system has been primed. Refer to Systems Operation, Testing and Adjusting, "Fuel System - Prime".
3. Check the diesel fuel for contamination. Refer to Systems Operation, Testing and Adjusting, "Fuel Quality - Test".
4. Check for air in the fuel system. Refer to Systems Operation, Testing and Adjusting, "Air in Fuel - Test".
5. Check that the fuel lines are tight and secured properly.
6. Check for fuel supply lines that are restricted.
7. Check the fuel filters.
8. Visually check the fuel tank for fuel. The fuel gauge may be faulty.
9. If the engine has a water separator, check for water in the fuel.
10. Ensure that the fuel supply valve is in the full OPEN position.
11. If the temperature is below 0 °C (32 °F), check for solidified fuel (wax).
12. If the repairs do not eliminate the problem proceed to "Air Intake and Exhaust System".

Air Intake and Exhaust System

1. Check the air filter restriction indicator, if equipped.
2. Ensure that the air filter is clean and serviceable.
3. Check the air intake and the exhaust system for the following defects:
 - Blockages
 - Restrictions

- Damage to the air intake and exhaust lines and hoses
4. Make all necessary repairs to the engine.
 5. Ensure that the repairs have eliminated the diagnostic code.
 6. If the problem has not been eliminated, proceed to "Individual Malfunctioning Cylinders".

Individual Malfunctioning Cylinders

1. With the engine speed at a fast idle, loosen the high pressure fuel line to the fuel injection nozzle of number 1 cylinder. Note if there is any reduction in engine speed. Tighten the high pressure fuel line to the fuel injection nozzle.
2. Individually repeat this procedure for each fuel injection nozzle. If there is no reduction in the engine speed refer to "Check the Turbocharger (if equipped)".
3. If all cylinders have been checked and no problems were detected proceed to "Valve Lash".

Valve Lash

1. Check the valve lash and reset the valve lash, if necessary. Refer to Systems Operation, Testing and Adjusting, "Engine Valve Lash - Inspect and Adjust".
2. If the repair does not eliminate the fault proceed to "Check for Low Compression".

Check for Low Compression

1. Remove the fuel injection nozzles and perform a compression test. Refer to Systems Operation, Testing and Adjusting, "Compression - Test" data.
2. Make all necessary repairs to the engine.
3. Ensure that the repairs have eliminated the faults.
4. If the repair does not eliminate the fault refer to "Checking the Fuel Injection Nozzles".

Examples of low compression are shown in the following list:

- Mechanical problem
- Faulty piston rings
- Worn cylinder bores
- Worn valves
- Faulty cylinder head gasket

- Damaged cylinder head

Checking the Fuel Injection Nozzles

1. Remove the fuel injection nozzles from the cylinder head. Refer to Disassembly and Assembly, "Fuel Injection Nozzle - Remove".
2. Check the fuel injection nozzles. Refer to Testing and Adjusting, "Fuel Injection Nozzle - Test".
3. Ensure that the repairs have eliminated the problems.
4. If the problem has not been eliminated, proceed to "Check the Turbocharger (if equipped)".

Check the Turbocharger (if equipped)

Note: The turbochargers that are equipped on 1100 Series engines are nonserviceable items. If any mechanical fault exists then the turbocharger must be replaced.

1. Ensure that the mounting bolts for the turbocharger are tight.
2. Check that the turbocharger drain is not blocked or restricted.
3. Check that the turbocharger housing is free of dirt and debris.
4. Check the turbocharger for worn bearings. Refer to Systems Operation, Testing and Adjusting, "Turbocharger - Inspect".
5. Check that the turbine blades rotate freely on the turbocharger. Refer to Systems Operation, Testing and Adjusting, "Turbocharger - Inspect".
6. Ensure that the wastegate on the turbocharger is adjusted correctly. Refer to Systems Operation, Testing and Adjusting, "Turbocharger - Inspect".
7. Make all necessary repairs to the engine.
8. Ensure that the repairs have eliminated the faults.
9. If the fault has not been eliminated proceed to "ECM Parameters".

ECM Parameters

1. Ensure that the problem is not a programmed parameter.
2. Ensure that the correct mode was selected by using the electronic service tool.
3. Use the electronic service tool to verify the correct engine rating for the engine.

4. Use the electronic service tool to verify the maximum engine speed limit.
5. Use the electronic service tool to reset the parameters to the OEM specifications.
6. Ensure that the repairs have eliminated the performance problems.
7. If the repairs have not eliminated the faults proceed to "Check the Signal for the Throttle Position Sensor".

Check the Signal for the Throttle Position Sensor

1. Use the electronic service tool and observe the signal for the throttle position sensor.
2. If the signal is erratic, refer to Troubleshooting, "Throttle Position Sensor Circuit - Test".
3. If the engine has a throttle switch refer to Troubleshooting, "Throttle Switch Circuit - Test".

i01798114

Coolant in Engine Oil

Note: This is NOT an electronic system problem.

Refer to Testing and Adjusting for information on determining the cause of this condition.

Probable Causes

- Engine oil cooler core
- Cylinder head gasket
- Cylinder head
- Cylinder block

Recommended Actions

Engine Oil Cooler Core

1. Drain the engine lubricating oil from the engine.
2. Check for leaks in the oil cooler core. Refer to Testing and Adjusting, "Cooling System" for the correct procedure. If a leak is found, install a new oil cooler core. Refer to Disassembly and Assembly, "Engine Oil Cooler - Remove" for the correct procedure. Fit new seals between the oil cooler and the oil cooler cover.

3. Remove the oil filter element or elements. Fit a new engine oil filter element or elements. Fill the crankcase with clean engine oil to the correct level. Refer to the Operation and Maintenance Manual, "Engine Oil and Filter - Change" for more information.

Cylinder Head Gasket

1. Remove the cylinder head. Refer to Disassembly and Assembly, "Cylinder Head - Remove" for the correct procedure.
2. Inspect the cylinder head gasket for faults and any signs of leakage.
3. Check the cylinder liner projection. Refer to Testing and Adjusting, "Basic Block" for more information. Correct the cylinder liner projection if it is incorrect.
4. If all of the cylinder liner projections were correct, and if there was no obvious signs of a faulty head gasket proceed to the recommended actions for the Cylinder Head.
5. If any of the cylinder liner projections were incorrect, and this had resulted in the failure of the head gasket, fit a new head gasket.
6. To fit a new cylinder head gasket, refer to Disassembly and Assembly, "Cylinder Head - Install" for the correct procedure.

Cylinder Head

Check the cylinder head for flatness. Refer to Systems Operation, "Cylinder Head - Inspect" for the correct procedure.

Check for cracks in the cylinder head. If a crack is found, repair the cylinder head and/or replace the cylinder head. Refer to Disassembly and Assembly, "Cylinder Head - Install" for the correct procedure.

If the cylinder head is flat and if the cylinder head is not cracked then refer to the recommended actions for the Cylinder Block.

Cylinder Block

Inspect the cylinder block for cracks. If a crack is found, repair the cylinder block or replace the cylinder block.

i01798115

Coolant Temperature Is Too High

Note: This is not an electronic system problem.

Refer to Testing and Adjusting for information on determining the cause of this condition.

Probable Causes

- Radiator fins
- Coolant level
- Radiator cap and/or pressure relief valve
- Combustion gases in the cooling system
- Engine cooling fan
- Water temperature regulators
- Restriction in the coolant system
- Coolant temperature gauge
- Coolant pump
- Excessive load on the system

Recommended Actions

Radiator Fins

Check the radiator fins for dirt, debris, and/or damage. Remove any dirt and/or debris and straighten any bent fins.

Coolant Level

1. Inspect the coolant level. If necessary, add coolant.
2. Check the cooling system for leaks. Repair any leaks immediately.

Radiator Cap and/or Pressure Relief Valve

1. Pressure test the cooling system. Refer to Testing and Adjusting, "Cooling System" for the correct procedure.
2. Check operation of the pressure relief valve and the radiator cap. If necessary, clean the components and/or replace the components.

3. Check that the seating surfaces of the pressure relief valve and the radiator cap are clean and undamaged.

Combustion Gases in the Cooling System

Switch off the engine and allow the engine to cool to below normal working temperature. Remove the pressure cap for the coolant system. Start the engine and inspect the coolant for the presence of bubbles. If bubbles are present in the coolant, combustion gases may be entering the cooling system. Check the cylinder head gasket. Refer to the recommended action for the cylinder head gasket within Troubleshooting, "Coolant in Engine Oil". Check the cylinder head for flatness. Refer to the recommended action for checking flatness of the cylinder head within Systems Operations, "Cylinder Head - Inspect". Fit the pressure cap if there are no bubbles in the coolant.

Water Temperature Regulator

Check the water temperature regulator for correct operation. Refer to Testing and Adjusting, "Cooling System" for the proper procedure. If necessary, replace the water temperature regulator. Refer to Disassembly and Assembly, "Water Temperature Regulator - Remove and Install" for more information.

Restriction in the Coolant System

1. Visually inspect the cooling system for collapsed hoses and/or other restrictions.
2. Clean the radiator and flush the radiator. Refer to Testing and Adjusting, "Cooling System".

Coolant Temperature Gauge

Compare the reading for the coolant temperature from the electronic service tool to the reading for the coolant temperature from a mechanical gauge.

Coolant Pump

Inspect the impeller of the coolant pump for damage and/or erosion. If necessary, repair the coolant pump or replace the coolant pump.

Excessive Load on the System

Reduce the load and verify that the condition does not reoccur.

i02270218

i01798117

ECM Will Not Accept Factory Passwords

WARNING

The connection of any electrical equipment and the disconnection of any electrical equipment may cause an explosion hazard which may result in injury or death. Do not connect any electrical equipment or disconnect any electrical equipment in an explosive atmosphere.

Probable Causes

One of the following items may not be recorded correctly on the electronic service tool:

- Passwords
- Serial numbers
- Total tattletale
- Reason code

Recommended Actions

1. Verify that the correct passwords were entered. Check every character in each password. Remove the electrical power from the engine for 30 seconds and then retry.
2. Verify that the electronic service tool is on the "Factory Password" screen.
3. Use the electronic service tool to verify that the following information has been entered correctly:
 - Engine serial number
 - Serial number for the electronic control module
 - Serial number for the electronic service tool
 - Total tattletale
 - Reason code

ECM Will Not Communicate with Other Systems or Display Modules

Probable Causes

- ECM
- Electrical connectors
- Data Link

Recommended Actions

1. Connect the electronic service tool to the service tool connector. If the ECM does not communicate with the electronic service tool, refer to Troubleshooting, "Electronic Service Tool Will Not Communicate with ECM".
2. Ensure that the following items are correctly installed and undamaged. Refer to Troubleshooting, "Electrical Connectors - Inspect".
 - J1/P1 ECM connector
 - J20/P20 Machine interface connector
 - Wiring to display modules
 - Wiring to other control modules
3. Troubleshoot the Data Link for possible problems. Refer to Troubleshooting, "Data Link Circuit - Test".

i01798118

Electronic Service Tool Will Not Communicate with ECM

Probable Causes

- The electronic service tool is not correctly configured.
- The cables to the electronic service tool are not connected correctly.
- The electronic service is not functioning.

i02270216

- The electrical power supply to the electronic service tool
- The engine protection device is disabling the power supply.
- The electrical power supply to the ECM
- The engine harness
- Battery voltage

Recommended Actions

Connect the communication adapter of the electronic service tool to the PC and to the diagnostic connector. Turn the ignition switch to the ON position. If the communication adapter for the electronic service tool activates, and the red power indicator lamp is ON, proceed to step 3. If the red power indicator lamp remains OFF proceed to step 1.

1. Check the battery voltage to the Data Link Connector. Refer to Troubleshooting, "Data Link Circuit - Test, Test Step 4".
2. Change the electronic service tool components. Refer to Troubleshooting, "Data Link Circuit - Test, Test Step 6".
3. Start the program for the electronic service tool. If the electronic service tool reports "Connected and 1 (or more) module detected" then STOP. If the electronic service tool reports "The interface hardware is not connected" then proceed to step 4. If the electronic service tool cannot connect to the ECM then proceed to step 5.
4. Inspect the cable from the PC to the communication adapter. Verify that the correct PC port has been used. Inspect the cable from the electronic service tool to the diagnostic connector. Change the electronic service tool components. Refer to Troubleshooting, "Data Link Circuit - Test, Test Step 6".
5. Check the battery voltage at the ECM if the electronic service tool cannot connect to the ECM. Refer to Troubleshooting, "Data Link Circuit - Test, Test Step 3".
6. Connect the electronic service tool directly to the ECM and follow the test procedure as Troubleshooting, "Data Link Circuit - Test, Test Step 5".
7. Connect the electronic service tool and the ECM to another battery. Proceed to Troubleshooting, "Data Link Circuit - Test, Test Step 7".

Engine Cranks but Will Not Start

Probable Causes

- Refer to the logged codes.
- Crank without injection (if equipped)
- Starting motor or starting circuit
- Valve lash
- Fuel injectors
- Air inlet heater starting aid
- Air intake and exhaust system
- Low compression (cylinder pressure)
- Fuel supply

Recommended Actions

Diagnostic Codes

Check for active diagnostic codes on the electronic service tool. Troubleshoot any active codes before continuing with this procedure.

Visual Checks

1. Visually inspect the engine for the following faults:
 - Missing components
 - Damaged components
 - Oil leaks
 - Coolant leaks
 - Fuel leaks
 - Hydraulic leaks
 - Check electrical cables for damage. Check that the electrical cables are properly secured.
 - Check for the proper level of fuel, oil, coolant, and hydraulic fluids
2. Try to start the engine. If the engine does not start, verify that the crankshaft is rotating. Use a suitable hand tool in order to rotate the crankshaft.

3. If the crankshaft rotates freely proceed to "Starting Motor Solenoid or Starting Circuit".
4. If the crankshaft does not rotate freely, check the engine for the following problems:
 - Seized piston
 - Defects in the drive gears
 - Fluid in the cylinder bores
 - Improper timing of valves

Crank Without Injection (If Equipped)

1. Check if the crank without injection plug is connected.
2. If the crank without injection plug has been connected, connect the normal running plug.
3. Check if the engine will start.
4. If the repairs do not eliminate the problem refer to Troubleshooting, "Crank without Inject Circuit - Test".

Starting Motor Solenoid or Starting Circuit

1. Turn the keyswitch to the OFF position.
2. Check the positive battery and negative battery connections to the ECM.
3. Perform a pull test on positive battery wires and negative battery wires. Refer to Troubleshooting, "Electrical Connectors - Inspect".
4. Check the negative battery connection on the ground stud.
5. Check the connections of starting motor terminals.
6. Check the starting motor solenoid.
7. Remove the starting motor and check the starter motor for proper operation. Check the pinion of the starting motor and check the flywheel ring gear.
8. Check the operation of the starting switch. Refer to Troubleshooting, "Electrical power Supply Circuit - Test".

Valve lash

1. Check the valve lash and reset the valve lash if it is necessary. Refer to Systems Operation, Testing and Adjusting, "Engine Valve Lash - Inspect and Adjust".

Ensure that the repairs have eliminated the active diagnostic codes before attempting to restart the engine.

If the engine will not start proceed to "Air Intake and Exhaust System".

Fuel Injectors

1. Remove the fuel injectors from the cylinder head. Refer to Disassembly and Assembly, "Fuel Injectors - Remove".
2. Check the fuel injectors. Refer to Systems Operation, Testing and Adjusting, "Fuel Injectors - Test".
3. If the repairs do not eliminate the problem proceed to "Air Inlet Heater Starting Aid".

Air Inlet Heater Starting Aid

1. Check that the air inlet heater is receiving both an electrical current and a supply of fuel. Check the operation of the air inlet heater starting aid. Refer to Systems Operation, "Air Inlet Heater - Test".
2. If the repairs do not eliminate the problem proceed to "Air Intake and Exhaust System".

Air Intake and Exhaust System

1. Check the air filter restriction indicator, if equipped.
2. Ensure that the air filter is clean and serviceable.
3. Check the air intake and exhaust systems for the following defects:
 - Blockages
 - Restrictions
 - Damage to lines or hoses
4. Repair any defects before attempting to restart the engine.
5. If the engine will not start proceed to "Low Compression".

Low Compression

1. Remove the fuel injectors and perform a compression test. Refer to Systems Operations, Testing and Adjusting, "Compression - Test" data.

Examples of low compression are shown in the following list:

- Outside temperatures are too cold.
 - Mechanical problem
 - Faulty piston rings
 - Worn cylinder bores
 - Worn valves
 - Faulty cylinder head gasket
 - Damaged cylinder head
2. Make all necessary repairs to the engine.
 3. Ensure that the repairs have eliminated the active diagnostic code.
 4. If the engine will not start proceed to "Fuel Supply".

Fuel Supply

1. Check the fuel pressure. Refer to Systems Operation, Testing and Adjusting, "Fuel System Pressure - Test".
2. Ensure that the fuel system has been primed. Refer to Systems Operation, Testing and Adjusting, "Fuel System - Prime".
3. Check the diesel fuel for contamination. Refer to Systems Operation, Testing and Adjusting, "Fuel Quality - Test".
4. Check for air in the fuel system. Refer to Systems Operation, Testing and Adjusting, "Air in Fuel - Test".
5. Check that the fuel lines are tight and secured properly.
6. Check for fuel supply lines that are restricted.
7. Check the fuel filters.
8. Visually check the fuel tank for fuel. The fuel gauge may be faulty.
9. If the engine has a water separator, check for water in the fuel.
10. Ensure that the fuel supply valve (if equipped) is in the full OPEN position.

11. If the temperature is below 0 °C (32 °F), check for solidified fuel (wax).

12. Check the fuel injection pump. Refer to Troubleshooting, "Fuel Injection Pump Circuit - Test".

i01798120

Engine Has Early Wear

Probable Causes

- Dirt in engine oil
- Leaks in air intake system
- Low oil pressure

Recommended Actions

Dirt in Engine Oil

1. Drain the oil from the crankcase and refill the crankcase with clean engine oil. Install new engine oil filters. Refer to the Operation and Maintenance Manual for more information.
2. Check the oil filter bypass valve for a weak spring or a broken spring. If the spring is weak or broken, replace the spring. Refer to Disassembly and Assembly, "Engine Oil Filter Base" for more information.

Leaks in Air Intake System

A leak in the air intake system may allow unfiltered air into the engine. Inspect the air intake system for leaks. Inspect all of the gaskets and the connections. Repair any leaks. Refer to Testing and Adjusting, "Air Intake System" for more information.

Low Oil Pressure

Refer to Troubleshooting, "Low Engine Oil Pressure" for the testing procedure. Repair any identified faults.

i01798121

Engine Misfires, Runs Rough or Is Unstable

The probable root causes are listed in order below:

Note: If the problem is intermittent and the problem cannot be duplicated, refer to Troubleshooting, “Intermittent Low Power or Power Cutout”.

Note: If the problem only occurs under certain conditions, test the engine under those conditions. Examples of certain conditions are high rpm, full load and engine operating temperature. Troubleshooting the symptoms under other conditions can give misleading results.

Probable Causes

- Refer to the logged codes.
- Fuel supply
- Air intake and exhaust system
- Individual malfunctioning cylinder
- Valve lash
- Low compression (cylinder pressure)
- Fuel injection nozzles
- Air inlet heater starting aid
- Engine speed/timing sensors
- Throttle position sensor
- Fuel injection pump

Recommended Actions

Logged Codes

Check for active diagnostic codes on the electronic service tool. Troubleshoot any active codes before continuing with this procedure.

Fuel Supply

1. Check the fuel pressure. Refer to Systems Operation, Testing and Adjusting, “Fuel System Pressure - Test”.
2. Ensure that the fuel system has been primed. Refer to Systems Operation, Testing and Adjusting, “Fuel System - Prime”.
3. Check the diesel fuel for contamination. Refer to Systems Operation, Testing and Adjusting, “Fuel Quality - Test”.

4. Check for air in the fuel system. Refer to Systems Operation, Testing and Adjusting, “Air in Fuel - Test”.
5. Check that the fuel lines are tight and secured properly.
6. Check for fuel supply lines that are restricted.
7. Check the fuel filters.
8. Visually check the fuel tank for fuel. The fuel gauge may be faulty.
9. If the engine has a water separator, check for water in the fuel.
10. Ensure that the fuel supply valve (if equipped) is in the full OPEN position.
11. If the temperature is below 0 °C (32 °F), check for solidified fuel (wax).
12. If the repairs do not eliminate the problem proceed to “Air Intake and Exhaust System”.

Air Intake and Exhaust System

1. Check the air filter restriction indicator, if equipped.
2. Ensure that the air filter is clean and serviceable.
3. Check the air intake and exhaust systems for the following defects:
 - Blockages
 - Restrictions
 - Damage to lines or hoses
4. If the repairs do not eliminate the problem proceed to “Individual Malfunctioning Cylinders”.

Individual Malfunctioning Cylinders

1. With the engine speed at a fast idle, loosen the high pressure fuel line to the fuel injection nozzle of number 1 cylinder. Note if there is any reduction in engine speed. Tighten the high pressure fuel line to the fuel injection nozzle.
2. Individually repeat this procedure for each fuel injection nozzle. If there is not a reduction in the engine speed proceed to “Check the Air Inlet Heater Starting Aid”.
3. If there is a reduction in engine speed proceed to “Valve Lash”.

Valve lash

1. Check the valve lash and reset the valve lash if it is necessary. Refer to Systems Operation, Testing and Adjusting, "Engine Valve Lash - Inspect and Adjust".
2. If the repair does not eliminate the fault proceed to "Check for Low Compression".

Check for Low Compression

Examples of low compression are shown on the following list:

- Mechanical problems
 - Faulty piston rings
 - Worn cylinder bores
 - Worn valves
 - Faulty cylinder head gasket
 - Damaged cylinder head
1. Remove the fuel injection nozzles and perform a compression test. Refer to Systems Operations, Testing and Adjusting, "Compression - Test" data.
 2. Make all necessary repairs to the engine.
 3. If the repair does not eliminate the fault proceed to "Check the Fuel Injection Nozzles".

Check the Fuel Injection Nozzles

1. Remove the fuel injection nozzles from the cylinder head. Refer to Disassembly and Assembly, "Fuel Injection Nozzle - Remove".
2. Check the fuel injection nozzles. Refer to Systems Operation, Testing and Adjusting, "Fuel Injection Nozzle - Test".
3. If the repairs do not eliminate the fault proceed to "Check the Air Inlet Heater Starting Aid".

Check the Air Inlet Heater Starting Aid

1. Check for proper operation of the air inlet heater starting aid. Refer to Systems Operation, Testing and Adjusting, "Electrical System".
2. If the repairs do not eliminate the fault refer to "Check the Engine Speed/Timing Sensors".

Check the Engine Speed/Timing Sensors

Note: There are two engine speed/timing sensors. One sensor is positioned in the cylinder block in order to sense the crankshaft position and the crankshaft speed. The other sensor is in the fuel injection pump in order to sense the pump's internal timing wheel and speed. The sensor in the fuel injection pump is not serviceable. If the sensor in the fuel injection pump is faulty then the fuel injection pump should be replaced.

1. Ensure that the engine speed/timing sensor is installed correctly to the cylinder block.
2. Ensure that the connectors and cables for the engine speed/timing sensors are connected correctly.
3. Check the wiring harness in order to ensure that the cables to the sensors are not too tight. This could cause an intermittent problem due to vibration.
4. If a fault with the engine speed/timing sensor is suspected refer to Troubleshooting, "Engine Speed/Timing Circuit - Test".
5. If a fault with the engine speed/timing sensor is not suspected proceed to "Check the Signal for the Throttle Demand Sensor".

Check the Signal for the Throttle Position Sensor

1. Use the electronic service tool and observe the signal for the throttle position sensor.
2. If the signal is erratic, refer to Troubleshooting, "Throttle Position Sensor Circuit - Test".
3. If the engine has a 10 position throttle switch refer to Troubleshooting, "Throttle Switch Circuit - Test".
4. If the repairs do not eliminate the fault proceed to "Check the Fuel Injection Pump".

Check the Fuel Injection Pump

Note: The fuel injection pumps that are installed by the factory on the 1100 series engines are non-serviceable items. If any mechanical fault or any electrical fault occurs within the fuel injection pump then the fuel injection pump must be replaced.

1. Use the electronic service tool to select the correct screen display. Refer to Troubleshooting, "Troubleshooting with a Diagnostic Code".
2. If the problem is not eliminated, check for active diagnostic fault codes.

3. Refer to Troubleshooting, "Fuel Injection Pump Circuit - Test".

i01798122

Engine Oil in Cooling System

Note: This is NOT an electronic system problem.

Refer to Testing and Adjusting for information on determining the cause of this condition.

Probable Causes

- Engine oil cooler core
- Cylinder head gasket
- Cylinder head

Recommended Actions

Engine Oil Cooler Core

1. Drain the coolant from the engine and the radiator. Drain the lubricating engine oil from the engine oil cooler. Refer to the Operation and Maintenance Manual for more information.
2. Inspect the engine oil cooler core for leaks. Refer to Testing and Adjusting, "Cooling System" for the correct procedure. If a leak is found, replace the oil cooler core. Refer to Disassembly and Assembly, "Engine Oil Cooler Core - Remove". Fit new seals between the oil cooler and the oil cooler cover.
3. Refill the crankcase with clean engine oil to the correct level. Refer to the Operation and Maintenance Manual for more information.

Cylinder Head Gasket

1. Remove the cylinder head. Refer to Disassembly and Assembly, "Cylinder Head - Remove" for the correct procedure.
2. Inspect the cylinder head gasket for faults and any signs of leakage.
3. Check the cylinder liner projection. Refer to Testing and Adjusting, "Basic Block" for the correct procedure.
4. If all of the cylinder liner projections were correct, and if there was no obvious signs of a faulty head gasket proceed to the recommended actions for the Cylinder Head.

5. If any of the cylinder liner projections were incorrect, and this had resulted in the failure of the head gasket, fit a new head gasket. Refer to Disassembly and Assembly, "Cylinder Head - Install" for the correct procedure.

Cylinder Head

1. Check the cylinder head for flatness. Refer to Systems Operation, "Cylinder Head - Inspect" for the correct procedure.
2. Check the cylinder head for cracks. If a crack is found, repair the cylinder head and/or replace the cylinder head. If the cylinder head is not cracked and the head is flat, fit the head. Refer to Disassembly and Assembly, "Cylinder Head - Install" for the correct procedure.

Thoroughly flush the coolant system in order to remove all traces of the engine lubricating oil from the coolant system. Fill the coolant system with coolant. Refer to Operation and Maintenance Manual for more information.

i01798123

Engine Speed Does Not Change

Note: Use this procedure only if the engine speed does not change.

Probable Causes

- Refer to logged codes.
- Throttle switch
- Throttle position sensor
- Engine speed/timing sensor

Recommended Repairs

Diagnostic Codes

Check for active diagnostic codes on the electronic service tool. Troubleshoot any active codes before continuing with this procedure.

If a problem with the throttle switch is suspected refer to Troubleshooting, "Throttle Switch Circuit - Test".

Refer to Troubleshooting, "Throttle Position Sensor Circuit - Test" if any of the following diagnostic codes are active.

- 91-08 Throttle Position Sensor Abnormal
- 774-08 Sec Throttle Position Signal Abnormal
- 41-03 8 Volt Sensor Power Supply Voltage more than normal
- 41-04 8 Volt Sensor Power Supply Voltage less than normal

Refer to Troubleshooting, "Engine Speed/Timing Sensor Circuit - Test" if any of the following diagnostic codes are active.

- 320-02 Speed/Timing Sensor intermittent loss of signal
- 320-11 Speed/Timing Sensor loss of signal

If there are no active diagnostic codes refer to the Troubleshooting Manual for your machine application.

i01798124

Engine Stalls at Low RPM

Probable Causes

- Refer to logged codes.
- Faulty fuel injection nozzles
- Fuel supply
- Accessory equipment
- Power mode control (if equipped)

Recommended Actions

Diagnostic Codes

Check for active diagnostic codes on the Electronic Service Tool. Troubleshoot any active codes before continuing with this procedure.

Fuel Injection Nozzles

1. Check for correct installation of fuel injection nozzles. Refer to Disassembly and Assembly, "Fuel Injection Nozzle - Install".
2. Check for proper operation of the fuel injection nozzle. Refer to Systems Operation, Testing and Adjusting, "Fuel Injection Nozzle - Test".

Fuel Supply

1. Check the fuel pressure. Refer to Systems Operation, Testing and Adjusting, "Fuel System Pressure - Test".
2. Ensure that the fuel system has been primed. Refer to Systems Operation, Testing and Adjusting, "Fuel System - Prime".
3. Check the diesel fuel for contamination. Refer to Systems Operation, Testing and Adjusting, "Fuel Quality - Test".
4. Check for air in the fuel system. Refer to Systems Operation, Testing and Adjusting, "Air in Fuel - Test".
5. Check that the fuel lines are tight and secured properly.
6. Check for fuel supply lines that are restricted.
7. Check the fuel filters.
8. Visually check the fuel tank for fuel. The fuel gauge may be faulty.
9. If the engine has a water separator, check for water in the fuel.
10. Ensure that the fuel supply valve (if equipped) is in the full OPEN position.
11. If the temperature is below 0 °C (32 °F), check for solidified fuel (wax).

NOTICE

Do not crank the engine continuously for more than 30 seconds. Allow the starting motor to cool for two minutes before cranking the engine again.

Accessory Equipment

Check all accessory equipment for problems that may create excessive load on the engine. Repair any damaged components or replace any damaged components.

Power Mode Control (If Equipped)

1. Check the Data Link. Refer to Troubleshooting, "Data Link Circuit - Test".
2. Check the engine wiring harness for defects. Refer to Troubleshooting, "Electrical Connectors - Inspect".
3. If there are no active diagnostic codes refer to the Troubleshooting Manual for your engine application.

i01798125

Engine Vibration

Note: This is NOT an electronic system problem.

Refer to Testing and Adjusting for information on determining the cause of this condition.

Probable Causes

- Engine supports
- Malfunctioning individual cylinder
- Valve lash
- Compression (cylinder pressure)
- Fuel injection nozzles
- Turbocharger (if equipped)

Recommended Actions

Engine Supports

1. Start the engine and run the engine through the speed range. Check for any of the following conditions:
 - Loose engine supports
 - Loose mounting brackets or broken mounting brackets
 - Loose bolts
 - Omitted bolts
2. Make all necessary repairs. Ensure that the repairs have eliminated the problem. If the vibration is still present proceed to "Malfunctioning Individual Cylinder".

Malfunctioning Individual Cylinder

1. With the engine speed at a fast idle, loosen the high pressure fuel line to the fuel injection nozzle of number 1 cylinder. Note if there is any reduction in engine speed. Tighten the high pressure fuel line to the fuel injection nozzle.
2. Individually repeat this procedure for each fuel injection nozzle. If there is no reduction in the engine speed proceed to "Check The Fuel Injection Nozzles".

3. If there is a reduction in engine speed proceed to "Valve Lash".

Valve Lash

1. Ensure that the valve lash is correct. Reset the valve lash if it is not correct. Refer to Systems Operation, Testing and Adjusting, "Engine Valve Lash - Inspect and Adjust".
2. If the repair does not eliminate the fault proceed to "Check for Low Compression (cylinder pressure)".

Check for Low Compression (cylinder pressure)

1. Remove the fuel injection nozzles from the cylinder head. Refer to Disassembly and Assembly, "Fuel Injection Nozzle - Remove".
2. Check the fuel injection nozzles. Refer to Testing and Adjusting, "Fuel Injection Nozzle - Test".
3. Perform a compression test on each cylinder. Refer to Systems Operation, Testing and Adjusting, "Compression - Test".
4. Ensure that the repairs have eliminated the problems.
5. If the problem has not been eliminated, proceed to "Check the Fuel Injection Nozzles".

Check the Fuel Injection Nozzles

1. Remove the fuel injection nozzles from the cylinder head. Refer to Disassembly and Assembly, "Fuel Injection Nozzle - Remove".
2. Check the fuel injection nozzles. Refer to Testing and Adjusting, "Fuel Injection Nozzle - Test".
3. Ensure that the repairs have eliminated the problems.
4. If the problem has not been eliminated, proceed to "Turbocharger (if equipped)".

Turbocharger (if equipped)

Note: The turbochargers that are equipped on 1100 Series engines are nonserviceable items. If any mechanical fault exists then the turbocharger must be replaced.

1. Ensure that the mounting bolts for the turbocharger are tight.

2. Check that the turbocharger drain is not blocked or restricted.
 3. Check that the turbocharger housing is free of dirt and debris.
 4. Check the turbocharger for worn bearings. Refer to Systems Operation, Testing and Adjusting, "Turbocharger - Inspect". The turbochargers that are equipped on 1100 Series engines are not serviceable. If any mechanical fault exists then the turbocharger must be replaced.
 5. Check that the turbine blades of the turbocharger rotate freely. Refer to Systems Operation, Testing and Adjusting, "Turbocharger - Inspect".
 6. Ensure that the wastegate on the turbocharger is adjusted correctly. Refer to Systems Operation, Testing and Adjusting, "Turbocharger - Inspect". The adjustment of the wastegate is set at the factory. If the adjustment of the wastegate is incorrect then the turbocharger must be replaced.
 7. Make all necessary repairs to the engine.
 8. Ensure that the repairs have eliminated the faults.
3. If the 1639-09 diagnostic code is active the machine security system is armed. Deactivate the machine security system and try to start the engine.
 4. If the engine will not start use the electronic service tool to check for logged diagnostic codes.
 5. Make repairs for all diagnostic codes. Ensure that the repair has eliminated the problem.
 6. If there are no active diagnostic codes refer to the Troubleshooting Manual for your machine application.

i01798126

Engine Will Not Crank

Probable Causes

- Machine security system
- Battery cables and/or batteries
- Starting motor solenoid or starting circuit
- Starting motor and/or flywheel ring gear
- Electrical power supply
- Internal engine problem

Recommended Repairs

Machine Security System

1. Verify that the correct keyswitch is being used. Turn the keyswitch to the ON position.
2. Use the electronic service tool in order to check if the 1639-09 Machine Security System is active. Verify that the lamp for the machine security system is on.

Battery Cables and/or Batteries

1. Inspect the main power switch, battery posts, and battery cables for loose connections and corrosion. If the battery cables are corroded, remove the battery cables and clean the battery cables. Clean the battery posts. Replace the cables. Tighten any loose connections.
2. Inspect the batteries.
 - a. Charge the batteries.
 - b. Load test the batteries.

Starting Motor Solenoid or Starting Circuit

1. Test the operation of the starting motor solenoid. Refer to Systems Operation/Testing and Adjusting, "Starting System".
2. Check the wiring to the starting motor solenoid.

Starting Motor and/or Flywheel Ring Gear

1. Test the operation of the starting motor. Check the wiring for the starting motor. Refer to System Operation, "System Starting".
2. Inspect the starter motor pinion and the flywheel ring gear for damage.

Electrical Power Supply

Check the electrical power supply. Refer to Troubleshooting, "Electrical Power Supply Circuit - Test".

Internal Engine Problem

1. Disassemble the engine. Refer to Disassembly and Assembly.
2. Inspect the internal components for the following conditions:

- Seizure
- Broken components
- Bent components

i01798127

Excessive Black Smoke

Probable Causes

- Air intake system or exhaust system
- Individual malfunctioning cylinder
- Valve lash
- Low compression (cylinder pressure)
- Fuel injection nozzles
- Turbocharger (if equipped)
- Broken 5 volt supply wire to the pressure sensor in the intake manifold
- ECM software

Recommended Actions

Air Intake System or Exhaust System

1. Check the air filter restriction indicator, if equipped.
2. Ensure that the air filter is clean and serviceable.
3. Check the air intake and the exhaust system for the following defects:
 - Blockages
 - Restrictions
 - Damage to the air intake and exhaust lines and hoses
4. Make all necessary repairs to the engine.
5. If the problem has not been eliminated, proceed to "Individual Malfunctioning Cylinder".

Individual Malfunctioning Cylinder

1. With the engine speed at a fast idle, loosen the high pressure fuel line to the fuel injection nozzle of number 1 cylinder. Note if there is any reduction in engine speed. Tighten the high pressure fuel line to the fuel injection nozzle.
2. Individually repeat this procedure for each fuel injection nozzle. If there is no reduction in the engine speed proceed to "Checking the Fuel Injection Nozzles".
3. If there is a reduction in engine speed proceed to "Valve Lash".

Valve Lash

Ensure that the valve lash is correct. Reset the valve lash if it is not correct. Refer to Testing and Adjusting, "Engine Valve Lash - Inspect/Adjust".

If the repair does not eliminate the fault proceed to "Low Compression (cylinder pressure)".

Low Compression (cylinder pressure)

Examples of low compression are shown in the following list:

- Mechanical problem
 - Faulty piston rings
 - Worn cylinder bores
 - Worn valves
 - Faulty cylinder head gasket
 - Damaged cylinder head
1. Remove the fuel injection nozzles and perform a compression test. Refer to Systems Operation, Testing and Adjusting, "Compression - Test" data.
 2. Make all necessary repairs to the engine.
 3. Ensure that the repairs have eliminated the faults.
 4. If the repair does not eliminate the fault proceed to "Checking the Fuel Injection Nozzles".

Checking the Fuel Injection Nozzles

1. Remove the fuel injection nozzles from the cylinder head. Refer to Disassembly and Assembly, "Fuel Injection Nozzle - Remove".

2. Check the fuel injection nozzles. Refer to Testing and Adjusting, "Fuel Injection Nozzle - Test".
3. Ensure that the repairs have eliminated the problems.
4. If the problem has not been eliminated, proceed to "Check the Turbocharger (if equipped)".

Check the Turbocharger (if equipped)

Note: The turbochargers that are equipped on 1100 Series engines are nonserviceable items. If any mechanical fault exists then the turbocharger must be replaced.

1. Ensure that the mounting bolts for the turbocharger are tight.
2. Check that the turbocharger drain is not blocked or restricted.
3. Check that the turbocharger housing is free of dirt and debris.
4. Check the turbocharger for worn bearings. Refer to Systems Operation, Testing and Adjusting, "Turbocharger - Inspect". The turbochargers that are equipped on 1100 Series engines are not serviceable. If any mechanical fault exists then the turbocharger must be replaced.
5. Check that the turbine blades rotate freely on the turbocharger. Refer to Systems Operation, Testing and Adjusting, "Turbocharger - Inspect".
6. Ensure that the wastegate on the turbocharger is adjusted correctly. Refer to Systems Operation, Testing and Adjusting, "Turbocharger - Inspect". The adjustment of the wastegate is set by the factory. If the adjustment of the wastegate is incorrect then the turbocharger must be replaced.
7. Make all necessary repairs to the engine.
8. Ensure that the repairs have eliminated the faults.
9. If the repairs have not eliminated the fault proceed to "Broken 5 volt supply wire".

Broken 5 volt Supply Wire

1. Check the 5 volt supply for the intake manifold pressure sensor. Refer to Troubleshooting, "5 volt Pressure Sensor Supply Circuit - Test".
2. If the repairs have not eliminated the fault proceed to "Verifying the ECM Software".

Verifying the ECM Software

1. Connect the electronic service tool to the diagnostic connector and check for the following conditions:
 - Check for the correct engine serial number
 - Check for the correct arrangement number
 - Check for the correct software
2. Use the electronic service tool to verify any active diagnostic codes.
3. If diagnostic codes are present, the ECM must be programmed with the correct information.

i01798128

Excessive Engine Oil Consumption

Probable Causes

- Oil level
- Engine crankcase breather
- Engine oil temperature
- Air intake and exhaust system
- Turbocharger (if equipped)
- Low compression (cylinder pressure)

Recommended Actions

Oil Level

Remove excess oil. Locate the source of the excess fluid. Repair the leaks that are causing the problems. Recheck all fluid levels.

Engine Crankcase Breather

1. Check the engine crankcase breather (if equipped) for blockage or restrictions.
2. Repair all defects. Verify that the repair has eliminated the problem.

Air Intake and Exhaust System

1. Check the air filter restriction indicator, if equipped.
2. Ensure that the air filter is clean and serviceable.

3. Check the air intake and the exhaust system for the following defects:
 - Blockages
 - Restrictions
 - Damage to the air intake and exhaust lines and hoses
4. Make all necessary repairs to the engine.
5. Ensure that the repairs have eliminated the diagnostic code.

Turbocharger (if equipped)

Note: The turbochargers that are equipped on 1100 Series engines are nonserviceable. If any mechanical fault exists then the turbocharger must be replaced.

1. Ensure that the mounting bolts for the turbocharger are tight.
2. Check that the turbocharger drain is not blocked or restricted.
3. Check that the turbocharger housing is free of dirt and debris.
4. Check the turbocharger for worn bearings. Refer to Systems Operation, Testing and Adjusting, "Turbocharger - Inspect". The turbochargers that are equipped on 1100 series engines are not serviceable. If any mechanical fault exists then the turbocharger should be replaced.
5. Check that the turbine blades rotate freely on the turbocharger. Refer to Systems Operation, Testing and Adjusting, "Turbocharger - Inspect".
6. Ensure that the wastegate on the turbocharger is adjusted correctly. Refer to Systems Operation, Testing and Adjusting, "Turbocharger - Inspect". The adjustment of the wastegate is set at the factory. If the adjustment of the wastegate is incorrect then the turbocharger must be replaced.
7. Make all necessary repairs to the engine.
8. Ensure that the repairs have eliminated the faults.

Low Compression (cylinder pressure)

1. Verify that the valve lash is correct. Refer to Systems Operation, "Engine Valve Lash - Inspect/Adjust".

1. Remove the fuel injection nozzles and perform a compression test. Refer to Systems Operation, Testing and Adjusting, "Compression - Test" data.
2. Make all necessary repairs to the engine.
3. Ensure that the repairs have eliminated the faults.

Examples of low compression are shown in the following list:

- Mechanical problem
 - Faulty piston rings
 - Worn cylinder bores
 - Worn valves
 - Faulty cylinder head gasket
 - Damaged cylinder head
4. Inspect the internal engine components. Replace any worn components.

i01798129

Excessive Valve Lash

Note: This is NOT an electronic system problem.

Refer to Testing and Adjusting for information on determining the cause of this condition.

Probable Causes

- Lubrication
- Valve lash
- Valve train components

Recommended Actions

Lubrication

1. Remove the valve mechanism covers. Refer to Disassembly and Assembly, "Valve Mechanism Cover - Remove and Install" for the correct procedure.
2. Check the lubrication in the valve compartment. Ensure that there is adequate engine oil flow in the valve compartment. The passages for the engine oil must be clean.

Valve Lash

Adjust the valve lash of the engine. Refer to Testing and Adjusting, "Air Intake and Exhaust System" for the correct procedure.

Valve Train Components

1. Inspect the following components of the valve train:
 - Rocker arms
 - Pushrods
 - Valve lifters
 - Camshaft
 - Valve stems
 - Rocker shafts
2. Check the components for the following conditions: abnormal wear, excessive wear, straightness, and cleanliness. If necessary, use new parts for replacement.

Note: If the camshaft is replaced, new valve lifters must also be used.

3. Adjust the valve lash of the engine. Refer to Testing and Adjusting, "Engine Valve Lash - Inspect/Adjust" for the correct procedure.

i01798130

Excessive White Smoke

Note: Some white smoke may be present during cold start-up conditions when the engine is operating normally. If the white smoke persists, there may be a problem.

Probable Causes

- Fuel supply
- Individual malfunctioning cylinder
- Valve lash
- Low compression (cylinder pressure)
- Air inlet heater starting aid
- Fuel injection nozzles
- Coolant temperature sensor circuit

- Engine pressure sensors

Recommended Actions

Fuel Supply

1. Check the fuel pressure. Refer to Systems Operation, Testing and Adjusting, "Fuel System Pressure - Test".
2. Ensure that the fuel system has been primed. Refer to Systems Operation, Testing and Adjusting, "Fuel System - Prime".
3. Check the diesel fuel for contamination. Refer to Systems Operation, Testing and Adjusting, "Fuel Quality - Test".
4. Check for air in the fuel system. Refer to Systems Operation, Testing and Adjusting, "Air in Fuel - Test".
5. Check that the fuel lines are tight and secured properly.
6. Check for fuel supply lines that are restricted.
7. Check the fuel filters.
8. Visually check the fuel tank for fuel. The fuel gauge may be faulty.
9. If the engine has a water separator, check for water in the fuel.
10. Ensure that the fuel supply valve (if equipped) is in the full OPEN position.
11. If the temperature is below 0 °C (32 °F), check for solidified fuel (wax).

Individual Malfunctioning Cylinder

1. With the engine speed at a fast idle, loosen the high pressure fuel line to the fuel injection nozzle of number 1 cylinder. Note if there is any reduction in engine speed. Tighten the high pressure fuel line to the fuel injection nozzle.
2. Individually repeat this procedure for each fuel injection nozzle.
3. If there is no reduction in the engine speed proceed to "Fuel Injection Nozzles".
4. If there is a reduction in engine speed proceed to "Valve Lash".

Valve Lash

1. Ensure that the valve lash is correct. Refer to Testing and Adjusting, "Engine Valve Lash - Inspect/Adjust". Rest the valve lash if it is not correct.
2. If the repair does not eliminate the fault proceed to "Low Compression (cylinder pressure)".

Low Compression (cylinder pressure)

1. Remove the fuel injection nozzles and perform a compression test. Refer to Systems Operation, Testing and Adjusting, "Compression - Test" data.
2. Make all necessary repairs to the engine.
3. Ensure that the repairs have eliminated the faults.

Examples of low compression are shown in the following list:

- Mechanical problem
 - Faulty piston rings
 - Worn cylinder bores
 - Worn valves
 - Faulty cylinder head gasket
 - Damaged cylinder head
4. If the repair does not eliminate the fault proceed to "Air Inlet Heater Starting Aid".

Air Inlet Heater Starting Aid

1. Verify that the air inlet heater is operating correctly. Refer to Testing and Adjusting, "Air Inlet Heater - Test".
2. If the repair does not eliminate the fault proceed to "Fuel Injection Nozzles".

Fuel Injection Nozzles

1. Remove the fuel injection nozzles from the cylinder head. Refer to Disassembly and Assembly, "Fuel Injection Nozzle - Remove".
2. Check the fuel injection nozzles. Refer to Testing and Adjusting, "Fuel Injection Nozzle - Test".
3. Ensure that the repairs have eliminated the problems.

4. If the problem has not been eliminated, proceed to "Coolant Temperature Sensor Circuit".

Coolant Temperature Sensor Circuit

1. Connect the electronic service tool to the diagnostic connector.
2. Monitor the display screen on the electronic service tool in order to verify the presence of active diagnostic codes for the coolant temperature. Refer to Troubleshooting, "Engine Temperature Sensor Open or Short Circuit - Test".

Engine Pressure Sensors

1. Connect the electronic service tool to the diagnostic connector.
2. Monitor the display screen on the electronic service tool in order to verify the presence of active diagnostic codes for the engine pressure sensors. Refer to Troubleshooting, "5 Volt Engine Pressure Sensor Supply Circuit - Test".

i01798131

Intake Air Temperature Is Too High

Probable Causes

- High ambient air temperature
- High coolant temperature
- High intake air restriction and/or high altitude
- Faulty intake manifold air temperature sensor and/or circuit
- Insufficient flow of cooling water through the aftercooler (if equipped)
- Insufficient flow of air through the aftercooler (if equipped)

Recommended Repairs

High Ambient Air Temperature

Determine if the ambient air temperature is within the design specifications for the cooling system.

Determine the cause of the high air temperature. Make corrections, when possible.

Coolant Temperature

Refer to Troubleshooting, “Coolant Temperature Is Too High”.

Check for High Intake Air Restriction and/or High Altitude

When intake air pressure is low, the turbocharger (if equipped) works harder in order to achieve the desired intake manifold pressure. This increases intake air temperature.

Measure the intake manifold pressure while the engine is operating under load. For specific data, refer to the Technical Marketing Information for the engine.

Intake Air Restriction

Check for plugged air filters. Check for obstructions to the air intake.

Replace the air filters and/or remove the obstruction from the air intake.

High Altitude

Make sure that the settings for the engine are correct for the altitude.

Check the Intake Manifold Air Temperature Sensor and/or the Circuit

Allow the intake manifold air temperature sensor to cool and remove the sensor. Check the reading for the intake air temperature. If the sensor is OK, the reading and the ambient temperature are approximately equal.

If the reading is not correct, replace the sensor with a sensor that is known to be good. Verify that the problem is solved.

Check for Sufficient Coolant Flow Through the Aftercooler (if equipped)

Check the intake temperature of the coolant for the aftercooler. Compare the reading to the regulated temperature. If the temperature is OK, check the outlet temperature of the coolant. A high temperature differential indicates an insufficient flow rate.

If there is a high differential between the intake temperature and the outlet temperature of the coolant for the aftercooler, perform the following procedures:

- Check the coolant circuit of the aftercooler for obstructions.

- Check the pump for proper operation.
- Make repairs, if necessary.

Check for Sufficient Flow of Air Through the Aftercooler (if equipped)

Determine the pressure differential of the intake air across the aftercooler. For specific data, refer to the Technical Marketing Information for the engine.

If the pressure differential of the air across the aftercooler does not match the specifications, clean the aftercooler.

i01798132

Intermittent Engine Shutdown

Note: Use this procedure only if the engine shuts down completely and the engine must be restarted.

Probable Causes

- Refer to the logged codes.
- Fuel supply
- Engine protection device (if equipped)
- Electrical connectors

Recommended Actions

Logged Codes

Check for any event and active diagnostic codes on the electronic service tool. Troubleshoot any active codes before continuing with this procedure.

Fuel Supply

NOTICE

Do not crank the engine continuously for more than 30 seconds. Allow the starting motor to cool for two minutes before cranking the engine again.

1. Check the fuel pressure. Refer to Systems Operation, Testing and Adjusting, “Fuel System Pressure - Test”.
2. Ensure that the fuel system has been primed. Refer to Systems Operation, Testing and Adjusting, “Fuel System - Prime”.
3. Check the diesel fuel for contamination. Refer to Systems Operation, Testing and Adjusting, “Fuel Quality - Test”.

4. Check for air in the fuel system. Refer to Systems Operation, Testing and Adjusting, "Air in Fuel - Test".
5. Check that the fuel lines are tight and secured properly.
6. Check for fuel supply lines that are restricted.
7. Check the fuel filters.
8. Visually check the fuel tank for fuel. The fuel gauge may be faulty.
9. If the engine has a water separator, check for water in the fuel.
10. Ensure that the fuel supply valve (if equipped) is in the full OPEN position.
11. If the temperature is below 0 °C (32 °F), check for solidified fuel (wax).

Engine Protection Device (if equipped)

1. Check if a warning lamp is ON.
2. Refer to Troubleshooting, "Indicator Lamp Circuit - Test".
3. Repair any faults and ensure that the engine protection device is not in operation.
4. If the fault has not been eliminated refer to "Electrical Connectors".

Electrical Connectors

1. Check for correct installation of ECM connectors at the following locations:
 - J1/P1 ECM connector
 - J20/P20 Machine interface connector
 - J401/P401 Speed/timing sensor connector
 - J100/P100 Intake manifold air temperature sensor connector
 - J103/P103 Engine coolant temperature sensor connector
 - J201/P201 Engine oil pressure sensor connector
 - J200/P200 Intake manifold pressure sensor connector
 - P40 Fuel injection pump connector

2. Refer to Troubleshooting, "Electrical Connectors - Inspect".
3. Use the electronic service tool to check for the following logged diagnostic code: 253-02 "Incorrect ECM Software". If this diagnostic code is logged, proceed to Troubleshooting, "Electrical Power Supply Circuit - Test".
4. Inspect the battery wires from the ECM back to the battery compartment. Refer to the Engine Wiring Diagram. Inspect the wires and the power relay. Check the power and ground connections to the ECM. Refer to Troubleshooting, "Fuel Injection Pump Circuit - Test" for more information.
5. Check the P40 VP30 fuel pump connector. Refer to Troubleshooting, "Fuel Injection Pump Circuit - Test".
6. Repair any faults and ensure that the faults have been eliminated.

i01798133

Intermittent Low Power or Power Cutout

Note: Use this procedure only if the engine does not shut down completely.

Probable Causes

- Refer to the logged codes.
- Electrical connectors
- Fuel supply
- Intake manifold pressure
- Air intake and exhaust system
- ECM connection
- Throttle position sensor

Recommended Repairs

NOTICE

Do not crank the engine continuously for more than 30 seconds. Allow the starting motor to cool for two minutes before cranking the engine again.

Diagnostic Codes

Check for active diagnostic codes on the electronic service tool. Troubleshoot any active codes before continuing with this procedure.

Electrical Connectors

1. Refer to Troubleshooting, "Electrical Connectors - Inspect".
2. Repair the electrical connectors or replace the electrical connectors.
3. Ensure that all the connector seals are in place and that the connectors have been correctly installed.
4. Ensure that the repairs have eliminated the fault. If the fault has not been eliminated proceed to "Fuel Supply".

Fuel Supply

1. Check the fuel pressure. Refer to Systems Operation, Testing and Adjusting, "Fuel System Pressure - Test".
2. Ensure that the fuel system has been primed. Refer to Systems Operation, Testing and Adjusting, "Fuel System - Prime".
3. Check the diesel fuel for contamination. Refer to Systems Operation, Testing and Adjusting, "Fuel Quality - Test".
4. Check for air in the fuel system. Refer to Systems Operation, Testing and Adjusting, "Air in Fuel - Test".
5. Check that the fuel lines are tight and secured properly.
6. Check for fuel supply lines that are restricted.
7. Check the fuel filters.
8. Visually check the fuel tank for fuel. The fuel gauge may be faulty.
9. If the engine has a water separator, check for water in the fuel.
10. Ensure that the fuel supply valve (if equipped) is in the full OPEN position.
11. If the temperature is below 0 °C (32 °F), check for solidified fuel (wax).

Check the Intake Manifold Pressure

1. Use the electronic service tool to verify the intake manifold pressure.
2. Turn the start switch to the ON position.
3. Check the intake manifold pressure. The pressure should read 0 kPa (0 Psi).
4. Use the electronic service tool to check for the following logged diagnostic codes:
 - 102-03 Intake Manifold Pressure Sensor open circuit or shorted high
 - 102-04 Intake Manifold Pressure Sensor shorted lowIf either of these diagnostic codes are logged, proceed to Troubleshooting, "Engine Pressure Sensor Open or Short Circuit - Test".
5. If no faults are found proceed to "Air Intake and Exhaust System".

Air Intake and Exhaust System

1. Check the air filter restriction indicator, if equipped.
2. Ensure that the air filter is clean and serviceable.
3. Check the air intake and exhaust systems for the following defects:
 - Blockages
 - Restrictions
 - Damage to the air intake and exhaust lines and hoses
4. Make all necessary repairs to the engine.
5. Ensure that the repairs have eliminated the diagnostic code.
6. If the problem has not been eliminated, proceed to "ECM Connection".

ECM Connection

1. Check that the J1/P1 connector is correctly connected.
2. Verify the proper pin positions for the power connections and the ground connections for the Engine Control Module (ECM).
3. If a problem is suspected with the ECM power and ground connections refer to Troubleshooting, "Electrical Power Supply Circuit - Test".

4. Verify that the ECM connections for the power and ground connections at the fuel pump are connected properly.
5. If a fault is suspected with the fuel injection pump power and ground connections refer to Troubleshooting, "Fuel Injection Pump Circuit - Test".
6. Repair any faults and ensure that the faults have been eliminated.
7. If the repairs do not eliminate the faults, proceed to "Check the Throttle Position Sensor".

Check the Throttle Position Sensor

1. Use the electronic service tool to observe the throttle position status.
2. Operate the engine at a maximum no-load speed. Check that the throttle position (%) is inside calibration (80 to 87%) at high idle if the programmed limit for the upper demand cannot be obtained.
3. If the engine speed is erratic, reduce the engine speed.
4. Check that the calibration of the low idle is within 20 to 27%.
5. Slowly increase the engine speed. Check that the engine speed is steady. Check that the position increases with more throttle.
6. Refer to Troubleshooting, "Throttle Position Circuit - Test".

i01798134

Low Engine Oil Pressure

NOTICE

Do not operate the engine with low oil pressure. Engine damage will result. If measured oil pressure is low, discontinue engine operation until the problem is corrected.

Probable Causes

- Engine oil level
- Engine oil pressure gauge
- Engine oil bypass valves

- Piston cooling jets (if equipped)
- Engine oil suction tube
- Engine oil pump
- Bearing clearance

Recommended Actions

Engine Oil Level

Inspect the engine oil level. If necessary, add oil.

Engine Oil Pressure Gauge

Check the actual engine oil pressure with a mechanical gauge. Compare the oil pressure reading from the electronic service tool to the pressure on the mechanical gauge.

Engine Oil Bypass Valves

1. Remove the engine oil bypass valves and clean the engine oil bypass valves. Clean the bores in the oil filter base for the bypass valves. Refer to Disassembly and Assembly, "Engine Oil Filter Base - Disassemble".
2. Install new engine oil filters. Refer to the Operation and Maintenance Manual for more information.

Piston Cooling Jets (if equipped)

Inspect the piston cooling jets for damage. Replace any piston cooling jet that appears to be cracked or broken. Refer to Disassembly and Assembly, "Piston Cooling Jets - Remove and Install" for the correct procedure.

Engine Oil Suction Tube

1. Check the inlet screen on the oil suction tube and remove any material that may be restricting oil flow.
2. Check the joints of the oil suction tube for cracks or a damaged O ring seal that may allow air leakage into the supply to the oil pump.

Engine Oil Pump

Inspect the components of the engine oil pump for excessive wear. Repair the oil pump or replace the oil pump, if necessary.

Bearing Clearance

Inspect the engine components for excessive bearing clearance. If necessary, replace the bearings and/or the components. The following list is an example of the components that should be inspected for excessive bearing clearance:

- Crankshaft main bearings
- Connecting rod bearings
- Camshaft bearings

i01798135

Low Power/Poor or No Response to Throttle

Probable Causes

- Refer to logged codes.
- Fuel supply
- Air intake and exhaust system
- Individual cylinder problem
- Valve lash
- Low compression (cylinder pressure)
- Fuel injection nozzles
- Turbocharger (if equipped)
- ECM parameters
- Electrical connectors

Recommended Actions

NOTICE

Do not crank the engine continuously for more than 30 seconds. Allow the starting motor to cool for two minutes before cranking the engine again.

Diagnostic Codes

Check for active diagnostic codes on the electronic service tool. Troubleshoot any active codes before continuing with this procedure.

Fuel Supply

1. Check the fuel pressure. Refer to Systems Operation, Testing and Adjusting, "Fuel System Pressure - Test".
2. Ensure that the fuel system has been primed. Refer to Systems Operation, Testing and Adjusting, "Fuel System - Prime".
3. Check the diesel fuel for contamination. Refer to Systems Operation, Testing and Adjusting, "Fuel Quality - Test".
4. Check for air in the fuel system. Refer to Systems Operation, Testing and Adjusting, "Air in Fuel - Test".
5. Check that the fuel lines are tight and secured properly.
6. Check for fuel supply lines that are restricted.
7. Check the fuel filters.
8. Visually check the fuel tank for fuel. The fuel gauge may be faulty.
9. If the engine has a water separator, check for water in the fuel.
10. Ensure that the fuel supply valve (if equipped) is in the full OPEN position.
11. If the temperature is below 0 °C (32 °F), check for solidified fuel (wax).
12. If the repairs do not eliminate the problem proceed to "Air Intake and Exhaust System".

Air Intake and Exhaust System

1. Check the air filter restriction indicator, if equipped.
2. Ensure that the air filter is clean and serviceable.
3. Check the air intake and the exhaust system for the following defects:
 - Blockages
 - Restrictions
 - Damage to the air intake and exhaust lines and hoses
4. Make all necessary repairs to the engine.
5. Ensure that the repairs have eliminated the diagnostic code.
6. If the problem has not been eliminated, proceed to "Individual Malfunctioning Cylinders".

Individual Malfunctioning Cylinders

1. With the engine speed at a fast idle, loosen the high pressure fuel line to the fuel injection nozzle of number 1 cylinder. Note if there is any reduction in engine speed. Tighten the high pressure fuel line to the fuel injection nozzle.
2. Individually repeat this procedure for each fuel injection nozzle.
3. If there is no reduction in the engine speed proceed to "Checking the Fuel Injection Nozzles".
4. If all cylinders have been checked and no problems were detected proceed to "Valve Lash".

Valve Lash

1. Check the valve lash and reset the valve lash, if necessary. Refer to Systems Operation, Testing and Adjusting, "Engine Valve lash - Inspect and Adjust".
2. If the repair does not eliminate the fault proceed to "Check for Low Compression".

Check for Low Compression

1. Remove the fuel injection nozzles and perform a compression test. Refer to Systems Operation, Testing and Adjusting, "Compression - Test".
2. Make all necessary repairs to the engine.
3. Ensure that the repairs have eliminated the faults.
4. If the repair does not eliminate the fault proceed to "Checking the Fuel Injection Nozzles".

Examples of low compression are shown in the following list:

- Mechanical problem
- Faulty piston rings
- Worn cylinder bores
- Worn valves
- Faulty cylinder head gasket
- Damaged cylinder head

Checking the Fuel Injection Nozzles

1. Remove the fuel injection nozzles from the cylinder head. Refer to Disassembly and Assembly, "Fuel Injection Nozzle - Remove".

2. Check the fuel injection nozzles. Refer to Testing and Adjusting, "Fuel Injection Nozzle - Test".
3. Ensure that the repairs have eliminated the problems.
4. If the problem has not been eliminated, proceed to "Check the Turbocharger (if equipped)".

Check the Turbocharger (if equipped)

Note: The turbochargers that are equipped on 1100 Series engines are nonserviceable items. If any mechanical fault exists then the turbocharger must be replaced.

1. Ensure that the mounting bolts for the turbocharger are tight.
2. Check that the turbocharger drain is not blocked or restricted.
3. Check that the turbocharger housing is free of dirt and debris.
4. Check the turbocharger for worn bearings. Refer to Systems Operation, Testing and Adjusting, "Turbocharger - Inspect". The turbochargers that are equipped to 1100 series engines are not serviceable. If any mechanical fault exists then the turbocharger should be replaced.
5. Check that the turbine blades rotate freely on the turbocharger. Refer to Systems Operation, Testing and Adjusting, "Turbocharger - Inspect".
6. Ensure that the wastegate on the turbocharger is adjusted correctly. Refer to Systems Operation, Testing and Adjusting, "Turbocharger - Inspect". The adjustment to the wastegate is set at the factory. If the adjustment of the wastegate is incorrect then the turbocharger must be replaced.
7. Make all necessary repairs to the engine.
8. Ensure that the repairs have eliminated the faults.
9. If the fault has not been eliminated proceed to "ECM Parameters".

ECM Parameters

1. Ensure that the problem is not a programmed parameter.
2. Use the electronic service tool to ensure that the correct mode was selected.
3. Use the electronic service tool to verify that the correct engine rating has been provided.

4. Use the electronic service tool to verify the maximum engine speed limit.
5. Use the electronic service tool to reset the parameters to the OEM specifications.
6. Ensure that the repairs have eliminated the performance problems.
7. If the repairs have not eliminated the faults proceed to "Electronic System Problem".

Electronic System Problem

1. Ensure that the correct mode is selected.
2. Turn the start switch to the ON position.
3. Use the electronic service tool to verify that the intake manifold pressure is 0 kPa (0 psi). Check the 5 V sensor supply for the intake manifold pressure. Refer to Troubleshooting, "5 Volt Engine Pressure Sensor Supply Circuit - Test".
4. Use the electronic service tool to verify the throttle position status.
5. Run the engine until the speed is equal to the maximum no-load speed.
6. If the maximum no-load speed can not be obtained refer to Troubleshooting, "Throttle Switch Circuit - Test" and Troubleshooting, "Mode Selection Circuit - Test".
7. If the engine speed is erratic refer to Troubleshooting, "Throttle Position Sensor Circuit - Test".

i01798136

Mechanical Noise (Knock) in Engine

Probable Causes

- Accessory equipment
- Valve train components
- Connecting rod and main bearings

Recommended Actions

Accessory Equipment

Isolate the source of the noise. Remove the suspect engine accessories. Inspect the suspect engine accessories. Repair the engine accessories and/or replace the engine accessories if any defects are found.

Valve Train Components

Remove the valve mechanism covers. Check the following items for damage: camshaft, valve springs, lifters, pushrods, and bridges. Thoroughly clean the valve train components. If the camshaft is being replaced, also replace the valve lifters. Ensure that all of the valves move freely. Replace any damaged parts.

Connecting Rod and Main Bearings

Inspect the connecting rod and main bearings. Also, inspect the bearing surfaces (journals) on the crankshaft. Replace any damaged parts.

i01798137

Noise Coming from Cylinder

Probable Causes

- Fuel quality
- Fuel injection nozzles
- Valve lash

Recommended Actions

Fuel Quality

Check the fuel quality. Remove unsatisfactory fuel from the fuel tank. Install new fuel filters. Use the proper grade of clean fuel in the fuel tank.

Fuel Injection Nozzles

1. Remove the fuel injection nozzles from the cylinder head. Refer to Disassembly and Assembly, "Fuel Injection Nozzle - Remove".
2. Check the fuel injection nozzles. Refer to Testing and Adjusting, "Fuel Injection Nozzle - Test".
3. Ensure that the repairs have eliminated the problems.

Valve Lash

Refer to Troubleshooting, "Excessive Valve Lash".

i01798138

Poor Acceleration or Response

Probable Causes

- Refer to the logged codes.
- Fuel supply
- Individual malfunctioning cylinders
- Valve lash
- Low compression
- Fuel injection nozzles
- Turbocharger (if equipped)
- ECM parameters
- Intake manifold pressure (engines that are turbocharged)

Recommended Repairs

Diagnostic Codes

Check for active diagnostic codes on the electronic service tool. Troubleshoot any active codes before continuing with this procedure.

Fuel Supply

NOTICE

Do not crank the engine continuously for more than 30 seconds. Allow the starting motor to cool for two minutes before cranking the engine again.

1. Check the fuel pressure. Refer to Systems Operation, Testing and Adjusting, "Fuel System Pressure - Test".
2. Ensure that the fuel system has been primed. Refer to Systems Operation, Testing and Adjusting, "Fuel System - Prime".
3. Check the diesel fuel for contamination. Refer to Systems Operation, Testing and Adjusting, "Fuel Quality - Test".

4. Check for air in the fuel system. Refer to Systems Operation, Testing and Adjusting, "Air in Fuel - Test".
5. Check that the fuel lines are tight and secured properly.
6. Check for fuel supply lines that are restricted.
7. Check the fuel filters.
8. Visually check the fuel tank for fuel. The fuel gauge may be faulty.
9. If the engine has a water separator, check for water in the fuel.
10. Ensure that the fuel supply valve (if equipped) is in the full OPEN position.
11. If the temperature is below 0 °C (32 °F), check for solidified fuel (wax).

Individual Malfunctioning Cylinder

1. With the engine speed at a fast idle, loosen the high pressure fuel line to the fuel injection nozzle of number 1 cylinder. Note if there is any reduction in engine speed. Tighten the fuel line to the fuel injection nozzle.
2. Individually repeat this procedure for each fuel injection nozzle.
3. If there is no reduction in the engine speed proceed to "Check the Fuel Injection Nozzles".
4. If there is a reduction in engine speed proceed to "Valve Lash".

Valve Lash

1. Check the valve lash and reset the valve lash, if necessary. Refer to Systems Operation, Testing and Adjusting, "Engine Valve lash - Inspect and Adjust".
2. If the repair does not eliminate the fault proceed to "Check for Low Compression".

Check for Low Compression

1. Remove the fuel injection nozzles and perform a compression test. Refer to Systems Operation, Testing and Adjusting, "Compression - Test" data.
2. Make all necessary repairs to the engine.
3. Ensure that the repairs have eliminated the faults.

4. If the repair does not eliminate the fault proceed to "Check the Fuel Injection Nozzles".

Examples of low compression are shown in the following list:

- Mechanical problem
- Faulty piston rings
- Worn cylinder bores
- Worn valves
- Faulty cylinder head gasket
- Damaged cylinder head

Check the Fuel Injection Nozzles

1. Remove the fuel injection nozzles from the cylinder head. Refer to Disassembly and Assembly, "Fuel Injection Nozzle - Remove".
2. Check the fuel injection nozzles. Refer to Testing and Adjusting, "Fuel Injection Nozzle - Test".
3. Ensure that the repairs have eliminated the problems.
4. If the problem has not been eliminated, proceed to "Check the Turbocharger (if equipped)".

Check the Turbocharger (if equipped)

Note: The turbochargers that are equipped on 1100 Series are non-serviceable items. If any mechanical fault exists then the turbocharger must be replaced.

1. Ensure that the mounting bolts for the turbocharger are tight.
2. Check that the turbocharger drain is not blocked or restricted.
3. Check that the turbocharger housing is free of dirt and debris.
4. Check the turbocharger for worn bearings. Refer to Systems Operation, Testing and Adjusting, "Turbocharger - Inspect". The turbochargers that are equipped to 1100 series engines are not serviceable. If any mechanical fault exists then the turbocharger must be replaced.
5. Check that the turbine blades rotate freely on the turbocharger. Refer to Systems Operation, Testing and Adjusting, "Turbocharger - Inspect".

6. Ensure that the wastegate on the turbocharger is adjusted correctly. Refer to Systems Operation, Testing and Adjusting, "Turbocharger - Inspect". The adjustment of the wastegate is set at the factory. If adjustment of the wastegate is required then the turbocharger must be replaced.

7. Make all necessary repairs to the engine.
8. Ensure that the repairs have eliminated the faults.
9. If the fault has not been eliminated proceed to "ECM Parameters".

ECM Parameters

1. Ensure that the problem is not a programmed parameter.
2. Use the electronic service tool in order to ensure that the correct mode was selected.
3. Use the electronic service tool to verify the correct engine rating for the engine.
4. Use the electronic service tool to verify the maximum engine speed limit.
5. Use the electronic service tool to reset the parameters to the OEM specifications.
6. Ensure that the repairs have eliminated the performance problems.
7. If the repairs have not eliminated the faults proceed to "Check Intake Manifold Pressure".

Check Intake Manifold Pressure (Engines that are turbocharged)

1. Turn the start switch to the ON position.
2. Use the electronic service tool to observe the intake manifold pressure. The intake manifold pressure should be 0 kPa (0 psi).

Troubleshooting with a Diagnostic Code

i01798139

CID 0041 FMI 03 8v Sensor Power Supply, Voltage More Than Normal

Conditions Which Generate This Code:

The ECM detects all of the following conditions:

- The ECM has been powered for at least three seconds.
- The ECM reads signal voltage that is above normal.

System Response:

The ECM will log the diagnostic code. The diagnostic code may be viewed on the electronic service tool.

The ECM will return the engine to low idle or a safe speed. The engine will remain at low idle or safe speed while the diagnostic code remains active.

Possible Performance Effect:

- Low power

Troubleshooting:

Perform the following diagnostic procedure: "Throttle Position Sensor Circuit - Test"

Results:

- OK – STOP.

i01798140

CID 0041 FMI 04 8v Sensor Power Supply, Voltage Less Than Normal

Conditions Which Generate This Code:

The ECM detects all of the following conditions:

- The ECM has been powered for at least three seconds.

- The ECM reads signal voltage that is below normal.

System Response:

The ECM will log the diagnostic code. The diagnostic code may be viewed on the electronic service tool.

The ECM will return the engine to idle or a safe speed. The engine will remain at idle or safe speed while the diagnostic codes remain active.

Possible Performance Effect:

- Low power

Troubleshooting:

Perform the following diagnostic procedure: "Throttle Position Sensor Circuit - Test"

Results:

- OK – STOP.

i01798141

CID 0091 FMI 02 Throttle Demand Sensor Erratic Or Intermittent

Conditions Which Generate This Code:

If the engine is equipped with a throttle switch then the signal from this switch is invalid.

If the engine is equipped with a throttle position sensor then the signal from the throttle idle validation switch is invalid.

System Response:

The ECM will log the diagnostic code. The diagnostic code may be viewed on the electronic service tool.

Possible Performance Effect:

The engine speed defaults to low idle or a predetermined safe speed.

The engine will remain at this speed while the diagnostic code remains active.

The reduction of speed is determined by the current speed of the engine.

When a fault is detected and the engine is above the predetermined safe speed, the engine will reduce speed to the safe speed.

When a fault is detected and the engine is below the predetermined safe speed, the engine will match the correct speed.

The throttle switch is ignored by the ECM until the fault is repaired.

The throttle switch will also be ignored by the ECM until the keyswitch has been turned to the OFF position and then back to the ON position.

Troubleshooting:

Proceed to "Test Step 1" if the engine is equipped with a throttle switch.

Proceed to "Test Step 2" if the engine is equipped with a throttle position sensor.

Test Step 1.

Perform the following diagnostic procedure: "Throttle Switch Circuit - Test"

Results:

- OK – STOP.

Test Step 2.

Perform the following diagnostic procedure: "Throttle Position Circuit - Test"

Results:

- OK – STOP.

i01798142

CID 0091 FMI 03 Throttle Demand Sensor Open Circuit Or Shorted High

Conditions Which Generate This Code:

The ECM detects all of the following conditions:

- The ECM has been powered for at least 3 seconds.
- The ECM reads a signal voltage that is above normal.

System Response:

The ECM will log the diagnostic code. The diagnostic codes may be viewed on the electronic service tool.

The ECM will return the engine to low idle or to the predetermined safe speed while the diagnostic code remains active.

Possible Performance Effect:

- Low power
- Reduced engine speed

Troubleshooting:

Perform the following diagnostic procedure: "Throttle Switch Circuit - Test"

Results:

- OK – STOP.

i01798143

CID 0091 FMI 04 Throttle Demand Sensor Shorted Low

Conditions Which Generate This Code:

The ECM detects all of the following conditions:

- The ECM has been powered for at least 3 seconds.
- The ECM reads a signal voltage that is below normal.

System Response:

The ECM will log the diagnostic code. The diagnostic code may be viewed on the electronic service tool.

The ECM will return the engine to the low idle or to the predetermined safe speed while the diagnostic code remains active.

Possible Performance Effect:

- Low power
- Reduced engine speed

Troubleshooting:

Perform the following diagnostic procedure: "Throttle Position Sensor Circuit - Test"

Results:

- OK – STOP.

i01798144

CID 0091 FMI 08 Throttle Demand Sensor Abnormal Signal

Conditions Which Generate This Code:

The ECM is not receiving a correct throttle position signal.

System Response:

The ECM will log the diagnostic code. The diagnostic code may be viewed on the electronic service tool.

The ECM returns the engine to low idle or a safe speed when the problem is detected. The diagnostic code is logged only if the engine is running. The electronic service tool will indicate DIAG and a throttle position of 0 percent while the diagnostic code is active. This will happen regardless of the position of the throttle pedal assembly. The engine will remain at low idle or at the safe speed while the code is active.

Troubleshooting:

The diagnostic code is likely to be caused by one of the following conditions:

- Open circuit for the throttle position sensor
- Open circuit for the voltage supply

Perform the following diagnostic procedure: “Throttle Position Sensor Circuit - Test”

Results:

- OK – STOP.

i01798145

CID 0091 FMI 12 Throttle Demand Sensor Out Of Calibration

Conditions Which Generate This Code:

The ECM detects the following conditions:

- A 5 volt failure
- A 5 volt fault

System Response:

The ECM will log the diagnostic code. The diagnostic code may be viewed on the electronic service tool.

The ECM will return the engine to the low idle or to the predetermined safe speed while the diagnostic code remains active.

Possible Performance Effect:

- Low power
- Reduced engine speed

Troubleshooting:

Perform the following diagnostic procedure: “Throttle Position Sensor Circuit - Test”

Results:

- OK – STOP.

i01798146

CID 0100 FMI 03 Engine Oil Pressure Sensor Open Circuit Or Shorted High

Conditions Which Generate This Code:

The ECM detects all of the following conditions:

- Signal voltage is above normal.
- The ECM has been powered for at least 15 seconds.
- CID 262-03 5V Sensor Power Supply, Voltage More Than Normal and CID 262-04 5V Sensor Power Supply, Voltage Less Than Normal are not active.

System Response:

The ECM will set the engine oil pressure to a default value.

The electronic service tool will display “Open/Short High” for the engine oil pressure on the status screen.

The ECM will generate a CID 100 FMI 03 diagnostic code on the Data Link. The diagnostic code will be displayed on the diagnostic screen of the electronic service tool.

Troubleshooting:

Perform the following diagnostic procedure:

Perform the following diagnostic procedure: "Engine Pressure Sensor Open or Short Circuit - Test"

Results:

- OK – STOP.

i01798147

CID 0100 FMI 04 Engine Oil Pressure Sensor Shorted Low

Conditions Which Generate This Code:

The ECM detects all of the following conditions:

- The signal voltage that is below normal
- The ECM has been powered for at least two seconds.
- CID 262-03 5V Sensor Power Supply, Voltage More Than Normal and CID 262-04 5V Sensor Power Supply, Voltage Less Than Normal are not active.

System Response:

The ECM will log the diagnostic code. The diagnostic code may be viewed on the electronic service tool. The ECM flags oil pressure as invalid data and a default value is used.

Troubleshooting:

Perform the following diagnostic procedure:

Perform the following diagnostic procedure: "Engine Pressure Sensor Open or Short Circuit - Test"

Results:

- OK – STOP.

i01877641

CID 0100 FMI 10 Engine Oil Pressure Sensor, Power Supply Open Circuit

Conditions Which Generate This Code:

If the 5 volt connection to the sensor is an open circuit, this fault will result in a logged code.

The Electronic Control Module (ECM) detects all of the following conditions:

- No other CID 0262 or CID 0102 codes are active.
- The engine speed is greater than 600 rpm.
- Engine oil pressure signal is within the expected range for this failure mode.
- Engine oil pressure signal remains abnormally constant because the variations in the sensor signal are too small.
- All of the above conditions occur simultaneously for a period of 10 seconds.

System Response:

The ECM will log the diagnostic code. The diagnostic code may be viewed on the electronic service tool. The ECM will flag the engine oil pressure as invalid data. The engine oil pressure is set to a default value.

Possible Performance Effect:

Perform the following diagnostic procedure: "Engine Pressure Sensor Open or Short Circuit - Test"

Results:

- OK – STOP.

i01798148

CID 0102 FMI 03 Intake Manifold Pressure Sensor, Open Circuit Or Shorted High

Conditions Which Generate This Code:

The Electronic Control Module (ECM) detects all of the following conditions:

- The ECM reads a signal voltage that is above normal.

- The ECM has been powered for at least fifteen seconds.
- CID 262-03 5V Sensor Power Supply Voltage More Than Normal and CID 262-04 5V Sensor Power Supply Voltage Less Than Normal are not active.

System Response:

The ECM will set the intake manifold pressure to a default value.

The electronic service tool will display “Open/Short High” for the intake manifold pressure on the status screen.

The ECM will generate a CID 102 FMI 03 diagnostic code on the Data Link. The diagnostic code will be displayed on a diagnostic screen of the electronic service tool.

Possible Performance Effect:

The engine could have low power while the diagnostic code is active.

Perform the following diagnostic procedure: “Engine Pressure Sensor Open or Short Circuit - Test”

Results:

- OK – STOP.

i01798149

CID 0102 FMI 04 Intake Manifold Pressure Sensor Shorted Low

Conditions Which Generate This Code:

The Electronic Control Module (ECM) detects all of the following conditions:

- The ECM detects a signal voltage that is below normal.
- The ECM has been powered for at least fifteen seconds.
- CID 262-03 5V Sensor Power Supply, Voltage More Than Normal and CID 262-04 5V Sensor Power Supply, Voltage Less Than Normal are not active.

System Response:

The ECM will set intake manifold pressure to a default value.

The electronic service tool will display “Short to Ground” for the intake manifold pressure on the status screen.

The ECM will generate a CID 102 FMI 04 diagnostic code on the Data Link. The diagnostic code will be displayed on a diagnostic screen of the electronic service tool.

Possible Performance Effect:

The engine could have low power while the diagnostic code is active.

Perform the following diagnostic procedure: “Engine Pressure Sensor Open or Short Circuit - Test”

Results:

- OK – STOP.

i01877642

CID 0102 FMI 10 Intake Manifold Pressure Sensor Power Supply Open Circuit

Conditions Which Generate This Code:

If the 5 volt connection to the sensor is an open circuit, this fault will result in a logged code.

The Electronic Control Module (ECM) detects all of the following conditions:

- No other CID 0262 or CID 0102 codes are active.
- The engine speed is greater than 600 rpm.
- The pressure sensor signal from the intake manifold is within the expected range for this failure mode.
- The pressure sensor signal from the intake manifold remains abnormally constant because the variations in the sensor signal are too small.
- All of the above conditions occur simultaneously for a period of 30 seconds.

System Response:

i01798151

The ECM will log the diagnostic code. The diagnostic code may be viewed on the electronic service tool. The ECM will flag the intake manifold pressure as invalid data. The intake manifold pressure is set to a default value.

Perform the following diagnostic procedure: "Engine Pressure Sensor Open or Short Circuit - Test"

Results:

- OK – STOP.

i01798150

CID 0105 FMI 03 Intake Manifold Temperature Sensor Open Circuit Or Shorted High

Conditions Which Generate This Code:

The Electronic Control Module (ECM) detects all of the following conditions:

- The ECM reads signal voltage that is above normal.
- The ECM has been powered for at least fifteen seconds.

System Response:

The ECM will log the diagnostic code. The diagnostic code may be viewed on the electronic service tool. The ECM flags the intake air temperature as invalid data and a default value is used.

Possible Performance Effect:

- Low power
- Poor cold starting

Troubleshooting:

Perform the following diagnostic procedure: "Engine Temperature Sensor Open or Short Circuit - Test"

Results:

- OK – STOP.

CID 0105 FMI 04 Intake Manifold Temperature Sensor Shorted Low

Conditions Which Generate This Code:

The Electronic Control Module (ECM) detects all of the following conditions:

- The ECM reads signal voltage that is below normal.
- The ECM has been powered for at least fifteen seconds.

System Response:

The ECM will log the diagnostic code. The diagnostic code may be viewed on the electronic service tool. The ECM flags the intake air temperature as invalid data and a default value is used.

Possible Performance Effect:

- Low power
- Poor cold starting

Troubleshooting:

Perform the following diagnostic procedure: "Engine Temperature Sensor Open or Short Circuit - Test"

Results:

- OK – STOP.

i01798152

CID 0110 FMI 03 Engine Coolant Temperature Sensor Open Circuit Or Shorted High

Conditions Which Generate This Code:

The Electronic Control Module (ECM) detects all of the following conditions:

- The ECM reads signal voltage that is above normal.
- The ECM has been powered for at least three seconds.

System Response:

The ECM will log the diagnostic code. The diagnostic code may be viewed on the electronic service tool. The ECM flags coolant temperature as invalid data and a default value is used.

Possible Performance Effect:

- Engine misfires
- Low power
- Reduced engine speed (rpm)
- Poor cold starting

Troubleshooting:

Further troubleshooting is required.

Perform the following diagnostic procedure: "Engine Temperature Sensor Open/Short Circuit - Test"

Results:

- OK – STOP.

i01798153

CID 0110 FMI 04 Engine Coolant Temperature Sensor Shorted Low

Conditions Which Generate This Code:

The Electronic Control Module (ECM) detects all of the following conditions:

- The ECM reads signal voltage that is below normal.
- The ECM has been powered for at least three seconds.

System Response:

The ECM will log the diagnostic code. The diagnostic code may be viewed on the electronic service tool. The ECM flags coolant temperature as invalid data and a default value is used.

Possible Performance Effect:

- Engine misfires
- Low power

- Reduced engine speed (rpm)
- Poor cold starting

Troubleshooting:

Further troubleshooting is required.

Perform the following diagnostic procedure: "Engine Temperature Sensor Open/Short Circuit - Test"

Results:

- OK – STOP.

i01798154

CID 0174 FMI 02 Fuel Temperature Sensor Erratic, Intermittent

Conditions Which Generate This Code:

Note: If both of the following diagnostic codes are active, then the fuel injection pump has suffered a complete failure of the electrical supply:

- 174-02
- 342-02

Both of the diagnostic codes will be active if there has been a communication fault between the Electronic Control Module (ECM) and the CAN Data Link for the fuel injection pump. When only one of the diagnostic codes is active there is not a fault with the electrical supply for the fuel injection pump.

If the ECM has detected 174-02 only, then one of the following conditions has been detected:

- The fuel temperature signal is erratic.
- Fuel temperature that is intermittent.

System Response:

The ECM will log the diagnostic code. The diagnostic code may be viewed on the electronic service tool. The ECM logs the diagnostic code only if the engine is running.

Possible Performance Effect:

- The engine may shut down.
- The engine will have low power.

Troubleshooting:

Further troubleshooting is required.

Perform the following diagnostic procedure: "Fuel Injection Pump Circuit - Test"

Results:

- OK – STOP.

i01798155

CID 0247 FMI 09 J1939 Datalink, Abnormal Update

Conditions Which Generate This Code:

The ECM has detected a loss of communications with another device on the J1939 data link.

System Response:

Some system functions may not operate properly.

The ECM will generate a CID 247 FMI 09 diagnostic code on the Data Link. The diagnostic code will be displayed on a diagnostic screen of the electronic service tool.

Perform the following diagnostic procedure: "Troubleshooting, "CAN Data Link Circuit - Test"."

Results:

- – STOP.

i01798156

CID 0253 FMI 02 Incorrect ECM Software

Conditions Which Generate This Code:

The personality module is the software that is loaded into the ECM in order to determine the power and torque outputs for a particular engine model and/or a particular engine application. The engine's personality module is loaded by the factory. A replacement personality module can be loaded into the ECM. The diagnostic code 0253 indicates that the personality module is neither the original personality module nor a replacement of the original personality module.

Note: The personality module is a flash personality module. The personality module is installed into the ECM by flash programming.

System Response:

The ECM will not log any diagnostic code except diagnostic code 0253. The diagnostic code may be viewed on a display module or on the electronic service tool. As a result of this code, the fuel injection pump is disabled for the engine. The engine will not start, and the electronic service tool will not be able to reset the diagnostic code in order to allow the engine to start.

Possible Performance Effect:

- Engine shutdown

Troubleshooting:

Check the part number of ECM Personality Module. Ensure that the personality module part number agrees with the original engine arrangement.

Expected Result:

The correct personality module is installed in the ECM.

Results:

- OK – The correct personality module is installed in the ECM. STOP.
- Not OK – The correct personality module is not installed in the ECM.

Repair: Reprogram the ECM with the correct personality module. Refer to Troubleshooting, "Flash Programming".

STOP.

i01798157

CID 0262 FMI 03 5v Sensor Power Supply, Voltage More Than Normal

Conditions Which Generate This Code:

The Electronic Control Module (ECM) detects all of the following conditions:

- The ECM reads signal voltage that is above normal.

- The ECM has been powered for at least three seconds.

System Response:

The ECM will log the diagnostic code. The diagnostic code may be viewed on the electronic service tool.

Possible Performance Effect:

- Low power
- Possible engine misfire

Troubleshooting:

Further troubleshooting is required.

Perform the following diagnostic procedure: "5 Volt Pressure Sensor Supply Circuit - Test"

Results:

- OK – STOP.

i01798158

CID 0262 FMI 04 5v Sensor Power Supply, Voltage Less Than Normal

Conditions Which Generate This Code:

The Electronic Control Module (ECM) detects all of the following conditions:

- The ECM reads signal voltage that is below normal.
- The ECM has been powered for at least three seconds.

System Response:

The ECM will log the diagnostic code. The diagnostic code may be viewed on the electronic service tool.

Possible Performance Effect:

- Low power
- Possible engine misfire

Troubleshooting:

Further troubleshooting is required.

Perform the following diagnostic procedure: "5 Volt Pressure Sensor Circuit - Test"

Results:

- OK – STOP.

i01897931

CID 0266 FMI 02 Incorrect Crank-without-inject inputs

Conditions Which Generate This Code:

The Electronic Control Module (ECM) detects all of the following conditions:

- The Crank Without Injection input from the normally closed relay is above 11.5 VDC.
- The Crank Without Injection input from the normally open relay is below 0.5 VDC.

System Response:

The diagnostic code may be viewed on a display module or on the electronic service tool.

The Crank Without Injection will be disabled.

Possible Performance Effect:

- None

Troubleshooting:

Perform the following diagnostic procedure: "Crank Without Injection Circuit - Test"

Results:

- OK – STOP.

i01798159

CID 0320 FMI 02 Speed And Timing Sensor Intermittent Loss Of Signal

Conditions Which Generate This Code:

The signal for the speed/timing sensor is intermittent. This speed/timing sensor is located near the flywheel housing.

System Response:

The Electronic Control Module (ECM) will use the speed/timing sensor in the fuel injection pump to determine engine speed. The ECM will log the diagnostic code. The diagnostic code may be viewed on the electronic service tool.

Possible Performance Effect:

There may be a slight change in engine response.

The ECM will limit the maximum engine speed to 1200 rpm.

If the signal is lost from both of the engine speed/timing sensors, the ECM will shut down the engine.

Perform the following diagnostic procedure: "Engine Speed/Timing Sensor Circuit - Test"

Results:

- OK – STOP.
- REPAIRED, OK – STOP.

i01798160

CID 0320 FMI 11 Speed And Timing Sensor Loss Of Signal

Conditions Which Generate This Code:

The signal for the speed/timing sensor is lost. This speed/timing sensor is located near the flywheel housing.

System Response:

The Electronic Control Module (ECM) will use the speed/timing sensor in the fuel injection pump to determine engine speed. The ECM will log the diagnostic code. The diagnostic code may be viewed on the electronic service tool.

Possible Performance Effect:

There may be a slight change in engine response.

The ECM will limit the maximum engine speed to 1200 rpm.

If the signal is lost from both of the engine speed/timing sensors, the ECM will shut down the engine.

Perform the following diagnostic procedure: "Engine Speed/Timing Sensor Circuit - Test"

Results:

- OK – STOP.
- REPAIRED, OK – STOP.

i01798161

CID 0342 FMI 02 Speed And Timing Sensor No.2 Intermittent Signal

Conditions Which Generate This Code:

Note: If both of the following diagnostic codes are active, then the fuel injection pump has suffered a complete failure of the electrical supply:

- 0174-02
- 0342-02

Both of the diagnostic codes will be active if there has been a communication fault between the Electronic Control Module (ECM) and the CAN data link for the fuel injection pump. If only the 0342-02 is active there is not a fault with the electrical supply for the fuel injection pump.

The signal for the speed/timing sensor in the fuel injection pump is intermittent or lost for less than one second.

System Response:

The Electronic Control Module (ECM) will log the diagnostic code. The ECM will force the engine to a default value or a safe speed. The diagnostic code may be viewed on the electronic service tool.

Possible Performance Effect:

The engine will shut down.

Test Step 1.

Perform the following diagnostic procedure: "Fuel Injection Pump Circuit - Test"

Results:

- OK – STOP.

Test Step 2.

Perform the following diagnostic procedure: "CAN Data Link Circuit - Test"

Results:

- OK – STOP.
- REPAIRED, OK – STOP.

i01798162

CID 0774 FMI 02 Throttle Demand Sensor No.2 Erratic Or Intermittent

Conditions Which Generate This Code:

The ECM detects one of the following conditions:

- Erratic data
- Intermittent data
- Incorrect data

System Response:

The ECM will log the diagnostic code. The diagnostic code may be viewed on the electronic service tool.

The ECM will return the engine to low idle or to a safe speed while the diagnostic code is active.

Possible Performance Effect:

The engine speed defaults to low idle or a predetermined safe speed.

The engine will remain at this speed while the diagnostic code remains active.

The reduction of speed is determined by the current speed of the engine.

When a fault is detected and the engine is above the predetermined safe speed, the engine will reduce speed to the safe speed.

When a fault is detected and the engine is below the predetermined safe speed, the engine will match the correct speed.

The throttle is ignored by the ECM until the fault is repaired.

The throttle switch will also be ignored by the ECM until the keyswitch has been turned to the OFF position and then back to the ON position.

- Low power
- Reduced engine speed

Perform the following diagnostic procedure: "Throttle Switch Circuit - Test"

Results:

- OK – STOP.

i01798163

CID 0774 FMI 03 Throttle Demand Sensor No.2 Open Circuit Or Shorted High

Conditions Which Generate This Code:

The ECM detects one of the following conditions:

- Voltage for the throttle position sensor is above normal.
- Invalid throttle position signal

System Response:

The ECM will log the diagnostic code. The diagnostic code may be viewed on the electronic service tool.

The ECM will return the engine to low idle or to a safe speed while the diagnostic code is active.

Possible Performance Effect:

- Low power
- Reduced engine speed

Troubleshooting:

Perform the following diagnostic procedure: "Throttle Position Sensor Circuit - Test"

Results:

- OK – STOP.

i01798165

CID 0774 FMI 08 Throttle Demand Sensor No.2 Abnormal Signal

Conditions Which Generate This Code:

The ECM detects one of the following conditions:

- Voltage for the throttle position sensor is abnormal.
- Invalid throttle position signal

System Response:

The ECM will log the diagnostic code. The diagnostic code may be viewed on the electronic service tool.

The ECM will return the engine to low idle or to a safe speed while the diagnostic code is active.

Possible Performance Effect:

- Low power
- Reduced engine speed

Perform the following diagnostic procedure: "Throttle Position Sensor Circuit - Test"

Results:

- OK – STOP.

i01798164

CID 0774 FMI 04 Throttle Demand Sensor No.2 Shorted Low

Conditions Which Generate This Code:

The ECM detects one of the following conditions:

- Voltage for the throttle position sensor is below normal.
- Invalid throttle position signal

System Response:

The ECM will log the diagnostic code. The diagnostic code may be viewed on the electronic service tool.

The ECM will return the engine to low idle or to a safe speed while the diagnostic code is active.

Possible Performance Effect:

- Low power
- Reduced engine speed

Troubleshooting:

Perform the following diagnostic procedure: "Throttle Position Sensor Circuit - Test"

Results:

- OK – STOP.

i01798166

CID 0774 FMI 12 Throttle Demand Sensor No.2 Out Of Calibration

Conditions Which Generate This Code:

The ECM detects one of the following conditions:

- Throttle position sensor signal is abnormal.
- Failure of the throttle position sensor

System Response:

The ECM will log the diagnostic code. The diagnostic code may be viewed on the electronic service tool.

The ECM will return the engine to low idle or to a safe speed while the diagnostic code is active.

Possible Performance Effect:

- Low power
- Reduced engine speed

Perform the following diagnostic procedure: "Throttle Position Sensor Circuit - Test"

Results:

- OK – STOP.

i01877645

CID 1627 FMI 03 Fuel Injection Pump Relay Did Not Turn Off

Conditions Which Generate This Code:

The ECM still receives signals from the relay of the fuel injection pump even though the ECM has already switched off the relay.

System Response:

The ECM will log the diagnostic code. The diagnostic code may be viewed on the electronic service tool.

Possible Performance Effect:

Perform the following diagnostic procedure: "Fuel Injection Pump Circuit - Test"

Results:

- OK – STOP.

i01798167

CID 1684 FMI 00 Fuel Injection Pump, Fuel Temperature More Than Normal

Conditions Which Generate This Code:

This code is generated by the fuel injection pump.

There are two conditions that will generate this code:

The fuel temperature may be above the recommended maximum operating temperature. The Perkins recommended maximum operating fuel temperature is 70 °C (158.0 °F) at the inlet to the fuel injection pump. The electronic fuel injection pump will note that the fuel temperature is too high.

There may be an internal fault within the fuel injection pump.

System Response:

The ECM will log the diagnostic code. The diagnostic code may be viewed on the electronic service tool.

The fuel injection pump will reduce the available quantity of fuel for injection if the fuel temperature is too high and the diagnostic code is still active. E054 High Fuel Temperature Derate is the event code that will be logged on the ECM.

Possible Performance Effect:

- The fuel injection pump will be derated.
- Low engine power
- Reduced engine speed

Test Step 1.

Check the fuel system for restrictions.

Check the fuel temperature.

Check for active diagnostic codes

Results:

- OK – STOP.

Test Step 2.

If the fault has not been eliminated refer to Systems Operation, Testing and Adjusting, "Fuel System - Inspect".

Results:

- OK – STOP.

i01798168

CID 1684 FMI 02 Fuel Injection Pump, Software Failure

Conditions Which Generate This Code:

This code is generated by the fuel injection pump.

The fuel injection pump will detect the following condition:

- An internal failure of the fuel injection pump software.

System Response:

The ECM will log the diagnostic code. The diagnostic code may be viewed on the electronic service tool.

The ECM will not allow the engine to start while the diagnostic code is active.

If the engine is running and the diagnostic code becomes active, the ECM will cause the engine to shutdown.

Possible Performance Effect:

The ECM will cause the engine to shutdown.

The engine will not start while the diagnostic code is active.

Troubleshooting:

Contact the Perkins Technical Support Centre in order to check if the software version is correct. Also check that there have been no software updates.

If the problem still exists contact the Perkins Technical Support Centre in order to change the fuel injection pump. The warranty of the fuel injection pump will be affected if the pump is replaced without prior consultation.

Replace the fuel injection pump. Refer to Disassembly and Assembly, "Fuel Injection Pump Remove and Install".

Check for active diagnostic codes.

Results:

- OK – STOP.

i01798169

CID 1684 FMI 03 Fuel Injection Pump, Fuelling Fault

Conditions Which Generate This Code:

This code is generated by the fuel injection pump.

The fuel injection pump will detect the following condition:

- An internal problem with the fuel injection pump

The ECM will log the diagnostic code. The diagnostic code may be viewed on the electronic service tool.

System Response:

The ECM will have no response to this active code. The engine may have reduced power.

Possible Performance Effect:

An incorrect amount of fuel may be injected into the cylinders. Continuing to use the engine under these conditions may lead to engine failure.

Troubleshooting:

Contact the Perkins Technical Support Centre in order to check if the software version is correct. Also check that there have been no software updates.

If the problem still exists contact the Perkins Technical Support Centre in order to change the fuel injection pump. The warranty of the fuel injection pump will be affected if the pump is replaced without prior consultation.

Replace the fuel injection pump. Refer to Disassembly and Assembly, "Fuel Injection Pump Remove and Install".

Check for active diagnostic codes.

Results:

- OK – STOP.

i01798170

CID 1684 FMI 04 Fuel Injection Pump, Supply Voltage Fault

Conditions Which Generate This Code:

This code is generated by the fuel injection pump.

The fuel injection pump detects one of the following conditions while the engine is running:

- Supply voltage below normal
- Intermittent signal

The ECM will log the diagnostic code. The diagnostic code may be viewed on the electronic service tool.

System Response:

Possible Performance Effect:

The diagnostic code is logged, but there will be no other system response.

- There is no obvious effect on engine performance.

Troubleshooting:

Further troubleshooting is required.

Perform the following diagnostic procedure: "Fuel Injection Pump Circuit - Test"

Results:

- OK – STOP.

i01798171

CID 1684 FMI 05 Fuel Injection Pump, Invalid Pulse Width

Conditions Which Generate This Code:

The Electronic Control Module (ECM) detects the following improper response from the fuel injection pump.

- Invalid "PWM" signal from the fuel injection pump

This invalid "PWM" is likely to be caused by a fault in the CAN Data Link in either the ECM or in the fuel injection pump.

The ECM will log the diagnostic code. The diagnostic code may be viewed on the electronic service tool.

The ECM will cause the fuel injection pump to stop injecting fuel. The ECM will then cause the engine to shut down while the diagnostic code is active.

Troubleshooting:

- A. Connect a test ECM in order to determine if the problem is in the original ECM or in the fuel injection pump.

Note: The parameters of the test ECM must match the parameters in the suspect ECM. If the test ECM resolves the problem, reconnect the suspect ECM. Verify that the problem returns. If the problem returns, replace the suspect ECM.

- B. If the ECM is OK, contact the Perkins Technical Support Centre in order to change the fuel injection pump. The warranty of the fuel injection pump will be affected if the pump is replaced without prior consultation.

Replace the fuel injection pump. Refer to Disassembly and Assembly, "Fuel Injection Pump Remove and Install".

- C. Check for active diagnostic codes.

Results:

- OK – STOP.

i01798172

CID 1684 FMI 07 Fuel Injection Pump, Mechanical Fault

Conditions Which Generate This Code:

This code is generated by the fuel injection pump.

The ECM will log the diagnostic code. The diagnostic code may be viewed on the electronic service tool.

System Response:

The ECM will cause the fuel injection pump to stop injecting fuel. The ECM will then cause the engine to shut down while the diagnostic code is active.

Possible Performance Effect:

The engine will shut down.

Troubleshooting:

Refer to Troubleshooting, "Fuel Injection Pump Circuit - Test".

Check for active diagnostic codes.

Results:

- OK – STOP.

i01798173

CID 1684 FMI 08 Fuel Injection Pump, Crankshaft Reference Fault

Conditions Which Generate This Code:

This code is generated by the fuel injection pump.

The fuel injection pump detects one of the following conditions:

- The fuel injection pump did not receive a position signal.
- The signal that is received by the fuel injection pump is incorrect.

The ECM will log the diagnostic code. The diagnostic code may be viewed on the electronic service tool.

System Response:

The fuel injection pump will use the engine speed/timing sensor in order to set the engine timing. The ECM will derate the engine power by 20% while the diagnostic code is active.

Possible Performance Effect:

The engine will experience any of the following conditions:

- Small loss of engine performance
- Increased emissions
- The engine may be difficult to start.

Troubleshooting:

Further troubleshooting is required.

Test Step 1.

Check for the following active code:

- Diagnostic code 320-02
- Diagnostic code 320-11

Results:

- Codes Active – Proceed to Test Step 2.

Test Step 2.

Perform the following diagnostic procedure: “Engine Speed/Timing Sensor Circuit - Test”

Results:

- OK – STOP.
- Not OK – Proceed to Test Step 3.

Test Step 3.

Pay close attention to the following areas:

- P1/J1 ECM connector
- P40/J40 Fuel injection pump connector
- P1:59 Engine position
- P40:8 Engine position

Refer to Troubleshooting, “Electrical Connectors - Inspect”.

Results:

- OK – Proceed to Test Step 4.

Test Step 4.

Check continuity between the following connections:

- P1:59 Engine position
- P40:8 Engine position

Expected Result:

If the fault is cleared then STOP.

If the fault still exists, repair the wire harness or replace the wire harness.

Ensure that the repairs have eliminated the problem.

Check for active diagnostic codes.

Results:

- OK – STOP.

i01798174

CID 1684 FMI 09 Fuel Injection Pump, CAN Fault

Conditions Which Generate This Code:

This code is generated by the fuel injection pump.

The fuel injection pump detects one of the following conditions:

- Failure of the CAN Data Link
- The ECM sends incorrect data.
- The fuel injection pump sends incorrect data.

The ECM will log the diagnostic code. The diagnostic code may be viewed on the electronic service tool.

System Response:

The ECM will cause the fuel injection pump to stop the injection of fuel.

Possible Performance Effect:

The ECM will cause the following conditions:

- The engine will shut down.
- The engine will not start.

Troubleshooting:

Further troubleshooting is required.

Connect a test ECM in order to determine if the original ECM is the cause of the problem.

Note: The parameters of the test ECM must match the parameters in the suspect ECM. If the test ECM resolves the problem, reconnect the suspect ECM. Verify that the problem returns. If the problem returns, replace the suspect ECM.

Expected Result:

If the fault is cleared then STOP.

If the fault is still active, perform the following Troubleshooting, "CAN Data Link Circuit - Test".

If the fault is cleared then STOP.

If the fault is still active, contact the Perkins Technical Support Centre in order to change the fuel injection pump. The warranty of the fuel injection pump will be affected if the pump is replaced without prior consultation.

Replace the fuel injection pump. Refer to Disassembly and Assembly, "Fuel Injection Pump Remove and Install".

Check for active diagnostic codes.

Results:

- OK – STOP.

i01798175

CID 1684 FMI 10 Fuel Injection Pump, Fuel Shutoff Signal Error

Conditions Which Generate This Code:

The Electronic Control Module (ECM) detects one of the following improper responses from the fuel injection pump.

- Open circuit
- Wire shorted high.
- Wire shorted low.

The ECM will log the diagnostic code. The diagnostic code may be viewed on the electronic service tool.

System Response:

The engine may shut down while the diagnostic code is active. Also, the engine may not start while the diagnostic code is active.

Troubleshooting:

Further troubleshooting is required.

Test Step 1.

Use a multimeter to check the following connections:

- J1:1
- P40:5

Note: While the engine is cranking and running, the battery voltage at terminal P40:5 should drop to 0 volts.

Ensure that the problem has been eliminated.

Results:

- Check for active diagnostic codes – STOP.

Test Step 2.

Connect a test ECM to the engine in order to determine if the original ECM is causing the problem.

Note: The parameters of the test ECM must match the parameters in the suspect ECM. If the test ECM resolves the problem, reconnect the suspect ECM. Verify that the problem returns. If the problem returns, replace the suspect ECM.

Results:

- OK – STOP.
- Not OK – Proceed to Test Step 3.

Test Step 3.

Contact the Perkins Technical Support Centre in order to change the fuel injection pump. The warranty of the fuel injection pump will be affected if the pump is replaced without prior consultation.

Replace the fuel injection pump. Refer to Disassembly and Assembly, “Fuel Injection Pump Remove and Install”.

Check for active diagnostic codes.

Results:

- OK – STOP.

i01798176

CID 1684 FMI 11 Fuel Injection Pump, Internal Sensor Fault

Conditions Which Generate This Code:

This code is generated by the fuel injection pump.

The problem is internal to the fuel injection pump.

There may be air in the fuel injection pump.

The voltage and/or resistance at the connectors for the fuel injection pump are incorrect.

The ECM will log the diagnostic code. The diagnostic code may be viewed on the electronic service tool.

System Response:

The ECM will derate the engine power by 20% while the diagnostic code is active.

Possible Performance Effect:

The engine may experience any of the following conditions while the diagnostic code remains active:

- Low power
- Reduced engine speed

Troubleshooting:

Further troubleshooting is required.

Test Step 1.

Check the tightness of all fuel line connections. Check for air in the fuel injection pump. Refer to Operation and Maintenance Manual, “Fuel System - Prime”.

Results:

- OK – Proceed to Test Step 2.

Test Step 2.

Refer to Troubleshooting, “Fuel Injection Pump Circuit - Test”.

Check for active diagnostic codes.

Results:

- OK – STOP.

i01798177

CID 1684 FMI 12 Fuel Injection Pump, Device Failure

Conditions Which Generate This Code:

This code is generated by the fuel injection pump.

The problem is internal to the fuel injection pump.

The ECM will log the diagnostic code. The diagnostic code may be viewed on the electronic service tool.

System Response:

The ECM will derate the engine power by 20% while the diagnostic code is active.

Possible Performance Effect:

While the diagnostic code is active the engine will experience the following conditions:

- Low power
- Reduced engine speed

Troubleshooting:

Contact the Perkins Technical Support Centre in order to check if the software version is correct. Also check that there have been no software updates.

If the problem still exists contact the Perkins Technical Support Centre in order to change the fuel injection pump. The warranty of the fuel injection pump will be affected if the pump is replaced without prior consultation.

Replace the fuel injection pump. Refer to Disassembly and Assembly, "Fuel Injection Pump Remove and Install".

Check for active diagnostic codes.

Results:

- OK – STOP.

i02271066

CID 1684 FMI 14 Fuel Injection Pump, No Communications

Conditions Which Generate This Code:

The ECM detects a communication failure with the fuel injection pump. The communication failure may be due to disconnected connectors for the fuel injection pump or a faulty wiring harness for the fuel injection pump.

System Response:

The ECM will log the diagnostic code. The diagnostic code may be viewed on the electronic service tool.

Possible Performance Effect:

The 1684-14 diagnostic code will not have any effect on the performance of the engine. 1684-14 is normally accompanied by 174-02 or 320-02. The 174-02 may cause the engine to have low power. If 320-02 is active, the ECM will limit the engine rpm to 1200 rpm.

Troubleshooting:

Further troubleshooting is required.

Test Step 1.

Perform the following diagnostic procedure: "CAN Data Link Circuit - Test"

Results:

- OK – STOP.
- Not OK – Proceed to Test Step 2.

Test Step 2.

Connect a test ECM in order to determine if the problem is in the original ECM or in the fuel injection pump.

Note: The parameters of the test ECM must match the parameters in the suspect ECM. If the test ECM resolves the problem, reconnect the suspect ECM. Verify that the problem returns. If the problem returns, replace the suspect ECM.

Check for active diagnostic codes.

Results:

- OK – STOP.
- Not OK, 1684-14 is still active. – Proceed to Test Step 3.

Test Step 3.

Contact the Perkins Technical Support Centre in order to check if the software version is correct. Also check that there have been no software updates.

If the problem still exists, the fuel injection pump must be replaced. Contact the Perkins Technical Support Centre in order to replace the fuel injection pump. The warranty of the fuel injection pump will be affected if the pump is replaced without prior consultation. Refer to Disassembly and Assembly, "Fuel Injection Pump Remove and Install".

Check for active diagnostic codes.

Results:

- OK – STOP.

i01798179

CID 1743 FMI 02 Engine Speed Mode Selection Switch State, Invalid State

Conditions Which Generate This Code:

The ECM has detected one of the following conditions:

- Erratic data
- Intermittent data
- Incorrect data

System Response:

The ECM will return the engine to the last good mode selection or setting. The ECM will not allow the engine to advance to another mode selection until the problem is repaired.

Possible Performance Effect:

The engine will start but the engine will have reduced engine speed.

Troubleshooting:

Refer to Troubleshooting, “Mode Selection Circuit - Test”.

Results:

- OK – STOP.

i01798180

CID 1894 FMI 02 Set Speed Control Disengage Switch State, Invalid State

Conditions Which Generate This Code:

The ECM detects one of the following conditions:

- Erratic data
- Intermittent data

- Incorrect data

System Response:

The engine speed fails to disengage from the set speed.

The ECM will log the diagnostic code. The diagnostic code may be viewed on the electronic service tool.

The ECM will have no response to this active code. There is no loss of engine performance.

Troubleshooting:

Further troubleshooting is required.

Refer to Troubleshooting, “Throttle Switch Circuit - Test”.

Results:

- OK – STOP.

i01798181

CID 1895 FMI 02 Set Speed Control Speed Toggle Switch, Invalid State

Conditions Which Generate This Code:

The ECM detects one of the following conditions:

- Erratic data
- Intermittent data
- Incorrect data

System Response:

The engine speed fails to disengage from the set speed.

The ECM will log the diagnostic code. The diagnostic code may be viewed on the electronic service tool.

The ECM will have no response to this active code. There is no loss of engine performance.

Troubleshooting:

Further troubleshooting is required.

Refer to Troubleshooting, “Throttle Switch Circuit - Test”.

Results:

- OK – STOP.

Troubleshooting with an Event Code

Event Codes

i01798182

Note: If a diagnostic code has already been logged then any associated event code to that fault will not be logged as well.

The ECM can log events. Events refer to engine operating conditions such as low oil pressure or high coolant temperature. Logged events usually indicate a mechanical problem instead of an electronic system problem.

Programmable Engine Parameters

The following features may be programmed:

- Engine Warning
- Engine Derate
- Engine Shutdown

When the features are activated the event will be logged in the ECM.

i01798183

E015 High Engine Coolant Temperature Derate

Conditions Which Generate This Code:

The engine has been running for at least 3 minutes. The engine coolant temperature has exceeded the trip point and the delay time has expired.

System Response:

The alarm output is activated. The event is logged.

Possible Performance Effect:

The engine power is reduced.

Troubleshooting:

Refer to Troubleshooting, "Coolant Temperature Is Too High".

Results:

- OK – STOP.

i01897925

E016 High Engine Coolant Temperature Shutdown

Conditions Which Generate This Code:

The engine has been running for at least 3 minutes. The engine coolant temperature has exceeded the trip point and the delay time has expired.

System Response:

If the engine shutdown is "ENABLED" the fuel will be shut off. The event will be logged.

Possible Performance Effect:

The engine is shut down.

Troubleshooting:

Refer to Troubleshooting, "Coolant Temperature Is Too High".

Results:

- OK – STOP.

i01798184

E017 High Engine Coolant Temperature Warning

Conditions Which Generate This Code:

The engine has been running for at least 3 minutes. The engine coolant temperature has exceeded the trip point and the delay time has expired.

System Response:

The alarm output is activated. The event is logged.

Possible Performance Effect:

The engine operation is not immediately affected. However, if the coolant temperature continues to rise, the engine will be derated.

Troubleshooting:

Refer to Troubleshooting, “Coolant Temperature Is Too High”.

Results:

- OK – STOP.

i01798185

E025 High Intake Air Temperature Derate

Conditions Which Generate This Code:

The engine has been running for at least 3 minutes. The intake air temperature has exceeded the setpoint and the delay time has expired. No other codes for the intake manifold air temperature are active.

System Response:

The alarm output is activated. The event is logged.

Possible Performance Effect:

The engine power is reduced.

Troubleshooting:

Refer to Troubleshooting, “Intake Manifold Air Temperature Is Too High”.

Results:

- OK – STOP.

i01798186

E027 High Intake Air Temperature Warning

Conditions Which Generate This Code:

The engine has been running for at least 3 minutes. The intake manifold air temperature has exceeded the trip point for the machine’s application and the delay time of 4 seconds has expired. No other codes for the intake manifold air temperature are active. The ECM will reset when the intake manifold air temperature cools below the trip point for the machine application.

The ECM detects the following conditions:

- The intake manifold air temperature is greater than 76 °C (168 °F) for the 1106 engine.
- The intake manifold air temperature is greater than 135 °C (275 °F) for the 1104 turbocharged engine.
- The intake manifold air temperature is greater than 82 °C (179 °F) for the aftercooled 1104 turbocharged engine.
- The intake manifold air temperature is greater than 112 °C (233 °F) for the 1104 naturally aspirated engine.

The ECM will reset when the following conditions are met:

- The intake manifold air temperature is less than 74 °C (165 °F) for the 1106 engine.
- The intake manifold air temperature is less than 133 °C (271 °F) for the 1104 turbocharged engine.
- The intake manifold air temperature is less than 80 °C (176 °F) for the aftercooled 1104 turbocharged engine.
- The intake manifold air temperature is less than 110 °C (230 °F) for the 1104 naturally aspirated engine.

System Response:

The alarm output is activated. The code is logged.

Possible Performance Effect:

The ECM will derate the engine. The ECM will continue to derate the engine at a higher rate as the intake manifold air temperature rises.

Troubleshooting:

Refer to Troubleshooting, “Intake Manifold Air Temperature Is Too High”.

Results:

- OK – STOP.

i01983787

E040 Low Engine Oil Pressure Shutdown

Conditions Which Generate This Code:

The ECM detects the following conditions:

- The engine has been running for at least 5 seconds.
- The engine speed is above 350 RPM.
- The engine oil pressure is less than 100 kPa (14.5 psi).
- The two second delay time has expired.
- No codes for the engine oil pressure sensor are active.

System Response:

The code is logged. The ECM will reset the shutdown when the oil pressure rises 21 kPa (3 psi) above the low pressure trip line for 20 seconds. If the engine shutdown input is “ENABLED” and there is no rise in oil pressure above the trip line, the fuel will be shut off after the two second delay has expired.

Possible Performance Effect:

The engine is shut down.

Troubleshooting:

Refer to Troubleshooting, “Low Engine Oil Pressure”.

Results:

- OK – STOP.

i01798188

E054 High Fuel Temperature Derate

Conditions Which Generate This Code:

The engine has been running for at least 3 seconds and the fuel temperature is above the trip point for the machine’s application.

System Response:

The warning lamp will flash while the “Derate” is active.

The electronic service tool will display “Engine Derate” in the first engine status box on any electronic service tool status screen.

The ECM will generate a EID E054 event code on the Data Link. The event code will be displayed on a diagnostic screen of the electronic service tool.

Troubleshooting:

- There may be a problem with the fuel system.
- There may be a problem with the fuel temperature sensor.

Test Step 1. Check for Diagnostic Codes.

- Connect the electronic service tool to the service tool connector.
- Turn the keyswitch to the ON position. The engine should be off.
- Check for any active diagnostic codes or logged diagnostic codes.

Expected Result:

There should be no diagnostic codes that are present.

Results:

- OK – Proceed to Test Step 2.
- Not OK

Repair: Repair the diagnostic codes that are present. Refer to the appropriate topic in the “Troubleshooting With a Diagnostic Code” section of this manual.

Ensure that the repair eliminates the problem.

STOP.

Test Step 2. Perform a Check of the Fuel System.

- Perform a check of the fuel system. Refer to the appropriate topic in Testing and Adjusting for possible causes.

Expected Result:

There are no problems with the fuel system.

Results:

- OK – There may be an intermittent problem.

Repair: Monitor the operation of the engine.

Repair the problem.

Ensure that the repair eliminates the problem.

STOP.

- Not OK

Repair: Repair the problem.

Ensure that the repair eliminates the problem.

STOP.

i01798189

E056 High Fuel Temperature Warning

Conditions Which Generate This Code:

The fuel temperature has exceeded the trip point and the delay time has expired. The ECM will reset the warning when the fuel temperature is above the reset value.

The ECM detects all of the following conditions:

- The engine has been running at least three minutes. This three minute delay begins once the engine speed is within 50 rpm of the low idle setting.
- 174-02 Fuel Temperature Sensor erratic or intermittent

System Response:

The ECM will log the event. The event code can be viewed on the diagnostic screen of the electronic service tool.

Troubleshooting:

- There may be a problem with the fuel system.
- There may be a problem with the fuel temperature sensor.

Test Step 1. Check for Diagnostic Codes.

- A. Connect the electronic service tool to the service tool connector.
- B. Turn the keyswitch to the ON position. The engine should be off.
- C. Check for any active diagnostic codes or logged diagnostic codes.

Expected Result:

There should be no diagnostic codes that are present.

Results:

- OK – Proceed to Test Step 2.

- Not OK

Repair: Repair the diagnostic codes that are present. Refer to the appropriate topic in the “Troubleshooting With a Diagnostic Code” section of this manual.

Ensure that the repair eliminates the problem.

STOP.

Test Step 2. Perform a Check of the Fuel System.

- A. Perform a check of the fuel system. Refer to the appropriate topic in Testing and Adjusting for possible causes.

Expected Result:

There are no problems with the fuel system.

Results:

- OK – There may be an intermittent problem.

Repair: Monitor the operation of the engine.

Repair the problem.

Ensure that the repair eliminates the problem.

STOP.

- Not OK

Repair: Repair the problem.

Ensure that the repair eliminates the problem.

STOP.

i01983749

E100 Low Engine Oil Pressure Warning

Conditions Which Generate This Code:

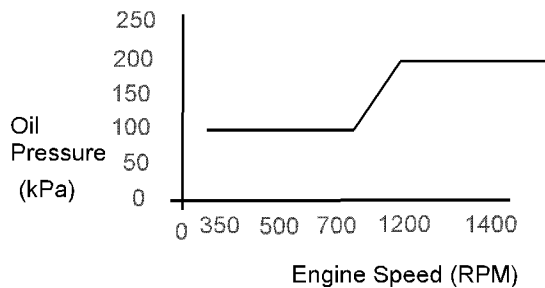

Illustration 17

g01028820

Oil pressure map for the 1104E engine

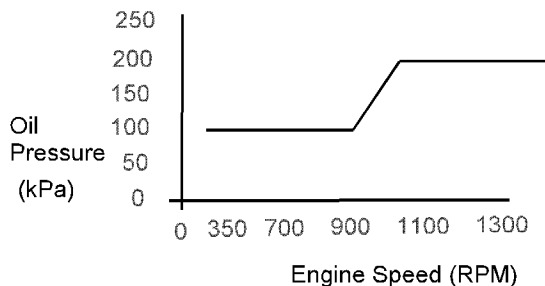

Illustration 18

g01028718

Oil pressure map for the 1106E engine

The Electronic Control Module (ECM) detects the following conditions:

- The engine has been running for at least 5 seconds.
- The engine speed is at least 350 rpm.
- Engine oil pressure is lower than the threshold for low oil pressure for more than 2 seconds.
- 100-03 "Engine Oil Pressure open/short to +batt" is not active.
- 100-04 "Engine Oil Pressure short to ground" is not active.
- 100-10 Engine Oil Pressure Sensor abnormal rate of change is not active.

System Response:

The ECM will log the event. The ECM will reset the warning when the oil pressure rises 21 kPa (3 psi) above the threshold for at least four seconds.

Possible Performance Effect:

- None

Troubleshooting:

- There may be a problem with the engine lubrication system.
- There may be a problem with the engine oil pressure sensor.

Test Step 1. Check for Active Diagnostic Codes.

A. Start the electronic service tool.

B. Turn the main power to the ON position.

C. Check for any Active Diagnostic Codes or Logged Diagnostic Codes.

Expected Result:

There should be no diagnostic codes that are present.

Results:

- OK – There are no diagnostic codes that are present. Proceed to test step 2.
- Not OK – There are diagnostic codes that are present.

Repair: Repair the diagnostic codes that are present. Refer to the appropriate topic in the "Troubleshooting With a Diagnostic Code" section of this manual. Ensure that the repair eliminates the problem.

STOP.

Test Step 2. Perform a Check of the Engine Lubrication System.

A. Perform a check of the engine lubrication system. Refer to the diagnostic procedure Troubleshooting, "Low Engine Oil Pressure".

Expected Result:

There should be no problems with engine oil pressure.

Results:

- OK – There are no problems with engine oil pressure. There may be an intermittent problem.

Repair: Monitor the operation of the engine. Repair the problem. Ensure that the repair eliminates the problem.

STOP.

- Not OK – There are problems with engine oil pressure.

Repair: Repair the problem. Ensure that the repair eliminates the problem.

STOP.

i01798191

E190 Engine Overspeed Warning

Conditions Which Generate This Code:

Engine speed is above 3000 rpm for the 1104 for more than 0.6 seconds or the engine speed is above 3300 RPM for the 1106 for more than 0.6 seconds. The reset point for both the 1104 and 1106 is 2800 RPM.

Note: This Event Code represents an event. This does not represent an electronic system fault.

System Response:

The event is logged in memory. The event may be viewed on a display module or the electronic service tool.

Possible Performance Effect:

None

Troubleshooting:

This event indicates excessive engine speed. This does not represent a problem with the Engine Control Module (ECM). This does not represent a problem with the Electronic Speed/Timing Sensor.

Engine Overspeed Warning

This event records the engine overspeed warning. No troubleshooting is required.

Expected Result:

Results:

- OK – STOP.

i01798192

E442 Engine Failed to Stop with a No-Fuel Command

Conditions Which Generate This Code:

The engine shutdown was slow when the keyswitch was turned to the OFF position.

The engine failed to shutdown when the keyswitch was turned to the OFF position.

The engine failed to shutdown when the fuel injection pump stopped fuel injection.

System Response:

If the engine still fails to shut down, the ECM will disable the power relay for the fuel injection pump.

The event code is logged in the ECM memory.

Possible Performance Effect:

Slow engine shutdown

Troubleshooting:

No troubleshooting will be required unless the diagnostic code 1684-09 is active.

Test Step 1.

Connect a test ECM in order to determine if the original ECM is the cause of the problem.

Note: The parameters of the test ECM must match the parameters in the suspect ECM.

If the test ECM resolves the problem, reconnect the suspect ECM.

Verify that the problem returns. If the problem returns, replace the suspect ECM.

Results:

- OK – STOP.
- Not OK – Proceed to Test Step 2.

Test Step 2.

Perform the following diagnostic procedure: "CAN Data Link Circuit - Test"

Results:

- OK – STOP.

i01798193

E883 Engine Failed To Stop When Fuel Solenoid Disengaged

Conditions Which Generate This Code:

The engine shutdown was slow when the keyswitch was turned to the OFF position.

The engine failed to stop when the ECM disabled the fuel injection pump.

The engine failed to shutdown when the keyswitch was turned to the OFF position.

System Response:

The ECM attempts to shut down the engine by instructing the fuel injection pump to stop fuel injection.

The event code is logged in the ECM memory.

Possible Performance Effect:

Slow engine shutdown

Troubleshooting:

No troubleshooting will be required unless the diagnostic code 1684-10 is active.

Test Step 1.

Use a multimeter to check the following connections:

- J1:1
- P40:5

Ensure that the problem has been eliminated.

Results:

- Check for active diagnostic codes – STOP.

Test Step 2.

Connect a test ECM to the engine in order to determine if the original ECM is causing the problem.

Note: The parameters of the test ECM must match the parameters in the suspect ECM.

If the test ECM resolves the problem, reconnect the suspect ECM.

Verify that the problem returns with the suspect ECM.

If the problem returns, replace the suspect ECM.

Results:

- OK – STOP.
- Not OK – Proceed to Test Step 3.

Test Step 3.

Replace the fuel injection pump. Refer to Disassembly and Assembly, "Fuel Injection Pump Remove and Install".

Results:

- OK – STOP.

Diagnostic Functional Tests

i01798194

5 Volt Engine Pressure Sensor Supply Circuit - Test

System Operation Description:

Use this procedure under the following situation:

Use this procedure if another procedure has directed you here. Also use this procedure if any of the following diagnostic codes are active:

- 262-03 5 Volt Sensor Power Supply voltage more than normal
- 262-04 5 Volt Sensor Power Supply voltage less than normal

The following background information is related to this procedure:

The Electronic Control Module (ECM) supplies regulated +5 VDC to the following sensors:

- J201/P201 Engine Oil Pressure Sensor
- J200/P200 Intake Manifold Pressure Sensor
- J40/P40 Throttle Sensor

The supply for the +5 V engine pressure sensor is routed from the ECM through ECM engine harness connector J1/P1 terminal 2 to terminal "A" of each pressure sensor connector. The supply voltage is 5.0 ± 0.5 VDC.

The +5 V short circuit diagnostic code is probably caused by a short circuit or an open circuit in the harness. The next probable cause is a sensor and the least probable cause is the ECM.

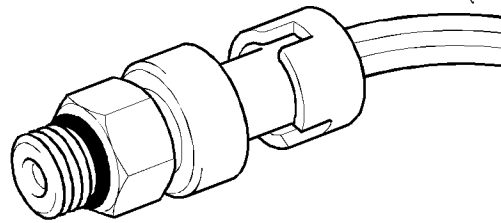

Illustration 19
The sensor for the intake manifold pressure

g00884730

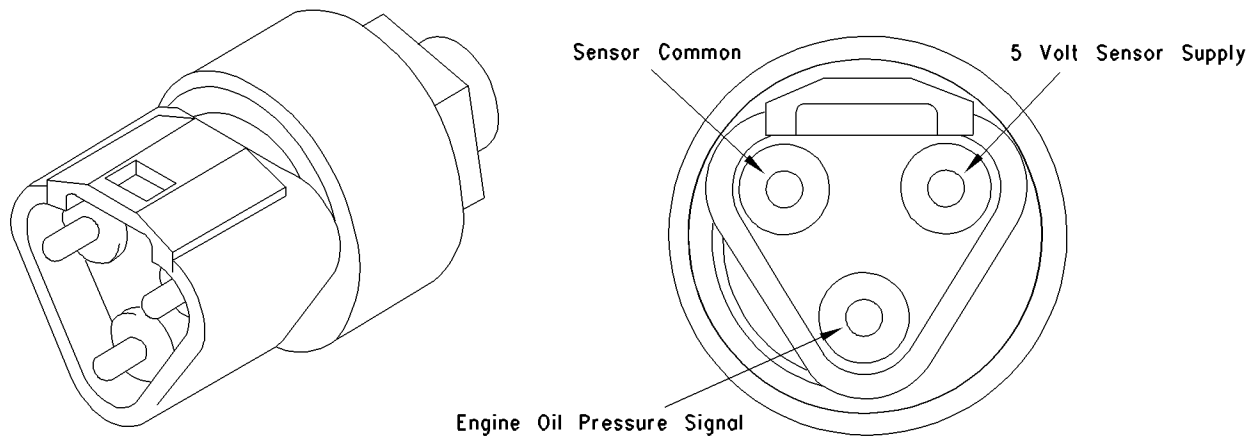

Illustration 20
Engine oil pressure sensor

g00835146

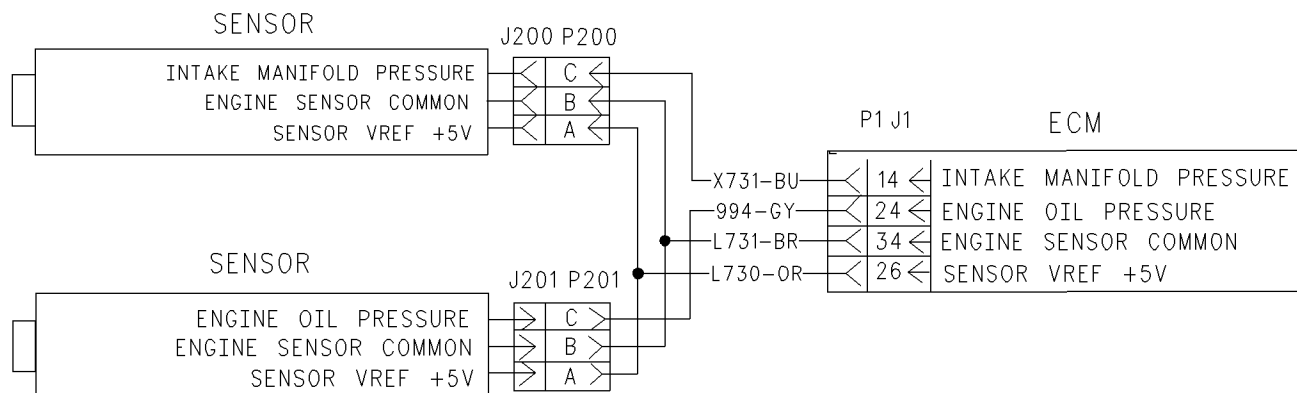

Illustration 21

g00954290

Schematic of the +5 V supply for the engine pressure sensors

Test Step 1. Inspect Electrical Connectors And Wiring.

A. Thoroughly inspect the following connections:

- P1/J1 ECM Engine harness connector
- P20/J20 MIC Machine harness connector
- P201/J201 Engine oil pressure sensor
- P200/J200 Intake manifold pressure sensor

Refer to Troubleshooting, “Electrical Connectors - Inspect” for details.

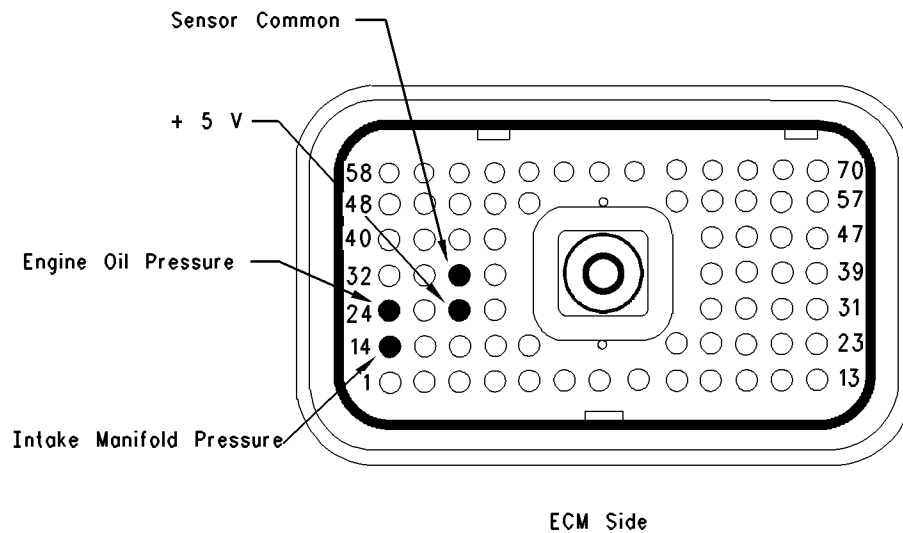

Illustration 22

g00954709

B. Perform a 45 N (10 lb) pull test on each of the wires in the ECM connector that are associated with the +5 V sensor supply:

- P1-14 Intake Manifold Pressure
- P1-24 Engine Oil Pressure
- P1-26 +5 V
- P1-34 Sensor Common

Refer to Illustration 22.

C. Check the ECM connector (Allen head screw) for the proper torque of 6.0 N·m (55 lb in).

D. Check the harness and wiring for abrasion and pinch points from the sensors back to the ECM.

Expected Result:

All connectors, pins and sockets should be completely coupled and/or inserted and the harness and wiring should be free of corrosion, abrasion or pinch points.

Results:

- OK – Proceed to Test Step 2.
- Not OK

Repair: Repair the connectors or wiring and/or replace the connectors or wiring. Ensure that all of the seals are properly in place and ensure that the connectors are completely coupled.

Verify that the repair eliminates the problem.

STOP.

Test Step 2. Check for Active Diagnostic Codes.

A. Connect the electronic service tool to the data link connector.

B. Turn the keyswitch to the ON position while the engine is OFF.

C. Monitor the active diagnostic code screen on the electronic service tool. Check and record any active diagnostic codes.

Note: Wait at least 15 seconds in order for the diagnostic codes to become active.

Expected Result:

Select the condition of the following codes:

- 262-03 5 Volt Sensor Power Supply, voltage more than normal

- 262-04 5 Volt Sensor Power Supply, voltage less than normal

Results:

- Active – Proceed to Test Step 3.
- Logged ONLY – Proceed to Test Step 5.
- Not Active or Logged – The +5 V supply is operating correctly at this time. STOP.

Test Step 3. Disconnect The ECM Engine Harness Connector From The ECM.

- A.** Connect the electronic service tool to the diagnostic connector.

 **WARNING**

Batteries give off flammable fumes which can explode.

To avoid injury or death, do not strike a match, cause a spark, or smoke in the vicinity of a battery.

NOTICE

Do Not connect the bypass harness to the battery until the 20 Amp in-line fuse has been removed from the +Battery line. If the fuse is not removed before connection to the battery, a spark may result.

- B.** Turn the keyswitch to the OFF position while the engine is off.

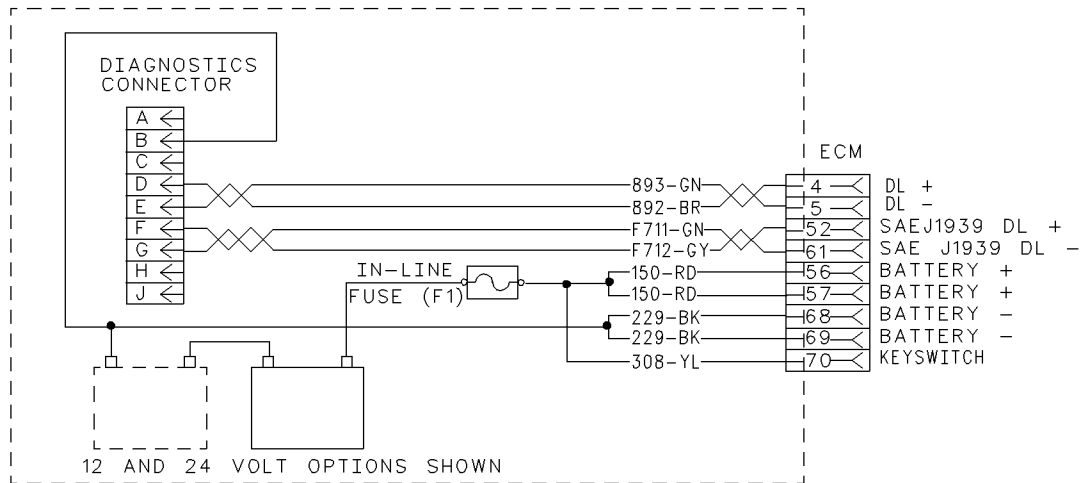

Illustration 23

g00954711

- C. Refer to Troubleshooting, "Engine Wiring Information" for wiring instructions.
- D. Disconnect J1/P1 ECM engine harness connector.
- E. Connect the J1 bypass harness to the ECM connector.
- F. Remove the fuse F1 from the bypass harness and from the battery circuit.
- G. Connect the unswitched battery cables directly to the battery terminals.
- H. Install the F1 fuse to the in-line fuse holder.

Note: The bypass harness directly connects the keyswitch circuit to the ECM. The ECM will have power until the connection to the + battery cable is disconnected. Remove the "F1" fuse from the in-line fuse holder in order to isolate the ECM.

- I. Turn the keyswitch to the ON position while the engine is off.
- J. Access the active diagnostic code screen on the electronic service tool. Check for one of the following active diagnostic codes:
 - 262-03 5 Volt Sensor Supply voltage more than normal

- 262-04 5 Volt Sensor Supply voltage less than normal

Note: When ECM engine harness connector J1/P1 is disconnected and the keyswitch is in the ON position, open circuit diagnostic codes will be "Active" or "Logged" for all of the engine sensors. This is normal.

Expected Result:

The +5 V diagnostic code is active when the ECM engine harness connector is disconnected.

Results:

- Yes – The +5 V diagnostic code is active when the ECM engine harness connector is disconnected.

Repair: Temporarily connect a test ECM to the engine J20/P20. The test ECM should be programmed with the same values and with the same parameters as the suspect ECM. Recheck for a +5 V diagnostic code. If a +5 V diagnostic code is not active, the original ECM is faulty. Reconnect the original ECM and check the +5 V diagnostic codes. If a +5 V diagnostic code becomes active, replace the ECM. If the ECM is replaced, the new ECM should be programmed with the same values and with the same parameter as the suspect ECM.

STOP.

- No – The +5 V sensor diagnostic code is no longer active when the harness is disconnected. Either the harness or a sensor that is attached to the harness is causing the problem. Reconnect the ECM engine harness connector. Proceed to Test Step 4.

Test Step 4. Disconnect The +5 V Sensors While Active Diagnostic Codes Are Being Monitored.

- A.** Connect the electronic service tool to the diagnostic connector.
- B.** Turn the keyswitch to the ON position while the engine is OFF.
- C.** Access the active diagnostic code screen on the electronic service tool. Verify that one of the following diagnostic codes is active:
- 262-03 5 Volt Sensor Supply voltage more than normal
 - 262-04 5 Volt Sensor Supply voltage less than normal
- D.** Disconnect the following sensors one at a time:
- Engine oil pressure sensor J201/P201
 - Intake manifold pressure sensor J200/P200
- E.** Wait for 30 seconds after each pressure sensor is disconnected while the electronic service tool is being monitored in order to verify that the disconnection of a specific sensor deactivates the +5 V diagnostic code.

Note: When the sensors are disconnected and the keyswitch is in the ON position, open circuit diagnostic codes will be active or logged when the +5 V diagnostic codes are no longer active. This is normal. Clear these diagnostic codes after this test step is completed.

Expected Result:

The original +5 V diagnostic code remains active.

Results:

- Yes – The +5 V diagnostic code is still active. The harness is the cause of the problem. Leave the sensors disconnected. Proceed to Test Step 5.
- No – The +5 V diagnostic code is not active when a specific sensor is disconnected.

Repair: Reconnect the sensor that is suspected of causing the problem. If the problem returns after the reconnection of the sensor, disconnect the sensor. If the problem disappears after the disconnection of the sensor, replace the sensor.

Clear all diagnostic codes. Verify that the repair eliminates the problem.

STOP.

Test Step 5. Check the Engine Harness.

Illustration 24

g00954709

- A.** Turn the keyswitch to the OFF position while the engine is OFF.
- B.** Disconnect ECM connector J1/P1. Verify that all of the +5 V engine pressure sensors that are attached to the ECM connectors are disconnected.
 - Engine oil pressure sensor J201/P201
 - Intake manifold pressure sensor J200/P200
- C.** Measure the resistance from P1-26 +5 V Engine Pressure Sensor to each of the following terminals:
 - P1:14 Intake manifold Pressure
 - P1:24 Engine Oil Pressure
 - a.** Wiggle the harness during the measurement in order to reveal any intermittent short condition.

Expected Result:

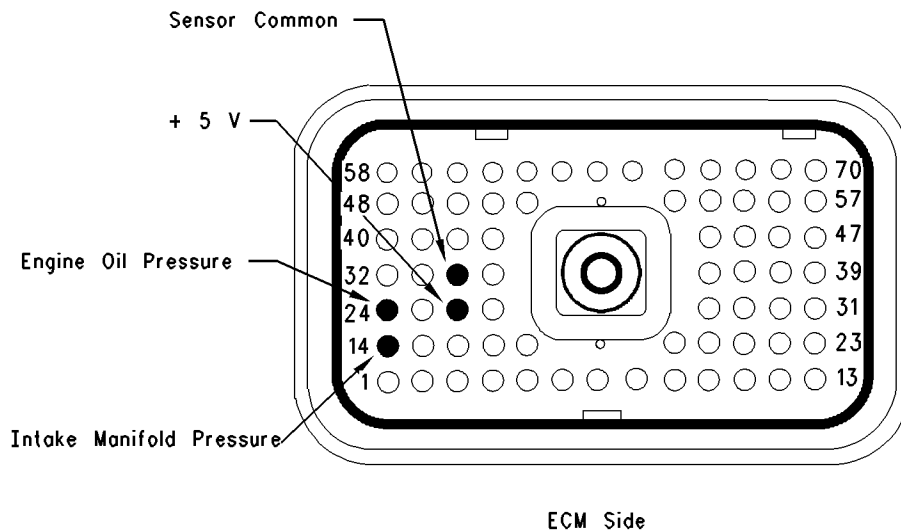
Each resistance measurement is more than 20 ohms.

Results:

- OK – The +5 V line is not shorted in the engine harness. Ensure that the engine harness is connected to the ECM and that all of the sensors are reconnected. There does not appear to be a problem at this time. Clear all diagnostic codes. Continue to troubleshoot until the original condition is resolved. STOP.
- Not OK

Repair: Replace the engine harness. Clear all logged diagnostic codes. Verify that the repair eliminates the problem.

STOP.

i01798196

Air Inlet Heater Circuit - Test**System Operation Description:**

The air inlet heater is a cold starting aid.

Use this procedure under the following circumstances:

- Check voltage for the air inlet heater starting aid.

- Check the operation of the air inlet heater starting aid.

Also use this procedure if another procedure has directed you here.

The air inlet heater starting aid is used to improve the engines' ability to start when the engine is cold. A reduction of white smoke is also a benefit of the air inlet heater starting aid.

The ECM controls the operation of the air inlet heater starting aid through the air inlet heater relay and P1:43.

There are two types of air inlet heater starting aid that equip 1100 Series engines. The 1104 uses glow plugs. The 1106 uses a fuelled starting aid.

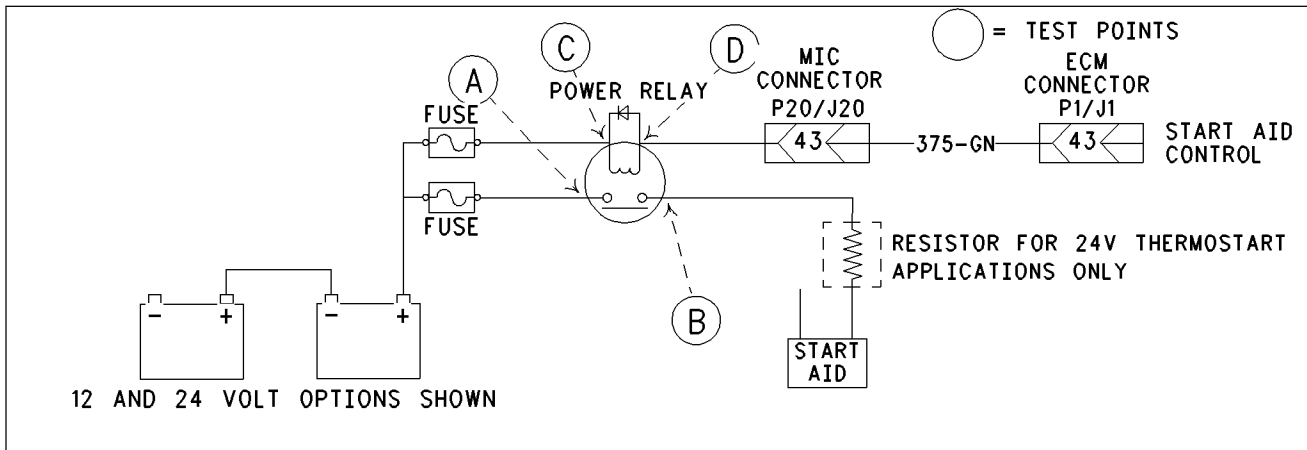

Illustration 25
Schematic for the air inlet heater starting aid

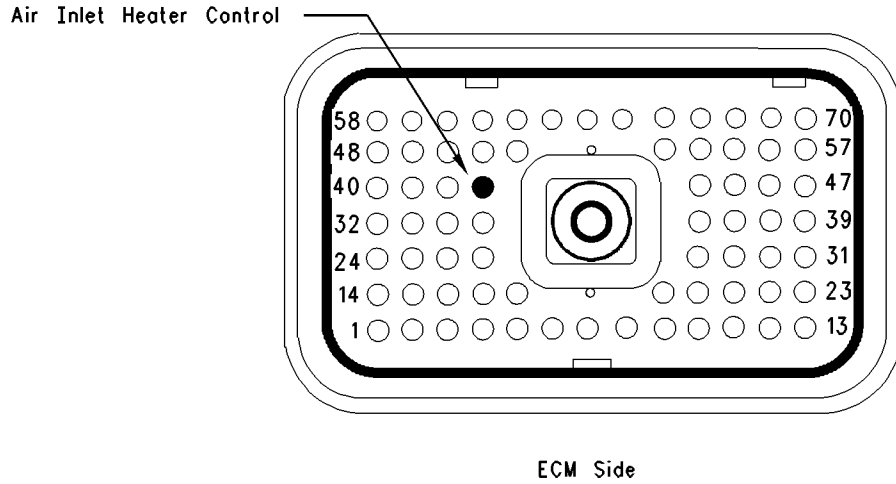

Illustration 26

g00878757

ECM pin locations for air inlet heater starting aid

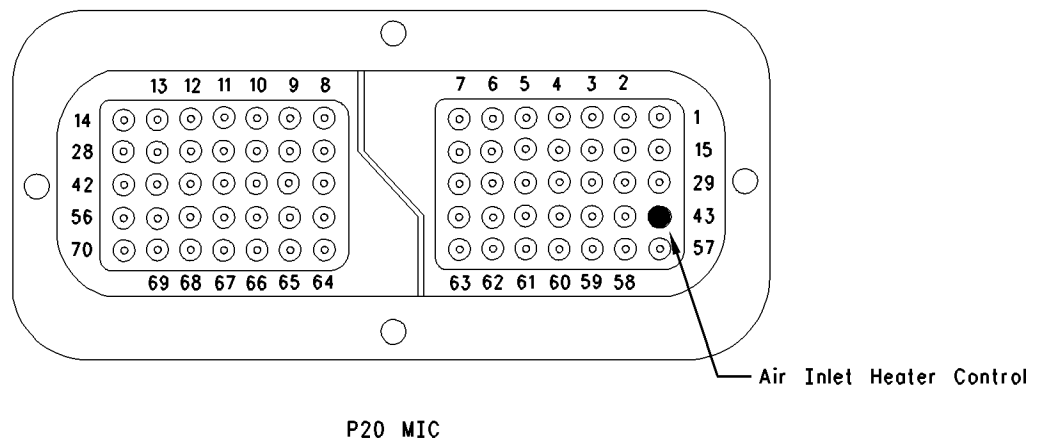

Illustration 27

g00954741

MIC pin locations for the air inlet heater starting aid

Test Step 1. Inspect Electrical Connectors and Wiring

- A. Thoroughly inspect the J1/P1 ECM connector and J20/P20 MIC. Inspect the terminal connections on the air inlet heater relay. Refer to Troubleshooting, "Electrical Connectors - Inspect" for details.
- B. Perform a 45 N (10 lb) pull test on each of the wires in the ECM connector that are associated with the air inlet heater starting aid. Refer to Illustration 26 and 27.
- C. Check the ECM connector (Allen head screw) for the proper torque of 6.0 N·m (55 lb in).
- D. Check the harness and wiring for abrasion and for pinch points from the sensors back to the ECM.

Expected Result:

All connectors, pins and sockets should be completely coupled and/or inserted and the harness and wiring should be free of corrosion, abrasion or pinch points.

Results:

- OK – The wiring and the connectors are good. Proceed to Test Step 2.
- Not OK – There is a problem with the wiring and the connectors.

Repair: Perform the following repair:

Repair the connectors or wiring and/or replace the connectors or wiring. Ensure that all of the seals are properly in place and ensure that the connectors are completely coupled.

Verify that the repair eliminates the problem.

STOP.

Test Step 2. Check the Supply to the Power Relay for the Air Inlet Heater Starting Aid

- A. Turn the ignition key switch to the ON position. Refer to Illustration 25.
- B. Measure the resistance between the following contacts:
 - A The supply side of the air inlet heater power relay and NEG battery
 - C Positive side of the air inlet heater relay coil and NEG battery

Expected Result:

The battery voltage is correct.

Results:

- OK – Proceed to Test Step 3.
- Not OK – There is a problem in the wires between the battery and the air inlet heater starting aid.

Repair: Check the fuse and wires. Repair the wires or replace the fuse. Verify that the repairs have eliminated the problem.

STOP.

Test Step 3. Check the Output from the Power Relay for the Air Inlet Heater Starting Aid

- A. Turn the ignition key switch to the ON position. Refer to Illustration 25.
- B. Measure the voltage between the following contacts:
 - (B)
 - NEG battery

Expected Result:

The battery has the proper voltage.

Results:

- OK – There is a problem in the wires between the relay and the air inlet heater starting aid.

Repair: Repair the wires or replace the wires. Verify that the repair has eliminated the problem.

STOP.

- Not OK – Proceed to Test Step 4.

Test Step 4. Ground the Input to the Power Relay at the MIC

- A. Turn the keyswitch to the OFF position.
- B. Disconnect P20 connector from the MIC and connect a 70 pin Breakout T.
- C. Connect the electronic service tool to the diagnostic connector.
- D. Turn the keyswitch to the ON position.

- E. Use the override setting in the electronic service tool in order to engage the air inlet heater starting aid.
- F. Measure the voltage between P20:43 air inlet heater control and socket 69 NEG battery on the Breakout T.

Expected Result:

The voltage is 0 volts when the air inlet heater starting aid is engaged.

Results:

- OK – Proceed to Test Step 5.
- Not OK – The problem is in the wires between the power relay for the air inlet heater starting aid and the MIC.

Repair: Repair the harness or replace the harness. Verify that the repair has eliminated the problem.

STOP.

Test Step 5. Ground the Input to the Power Relay at the ECM connector

- A. Turn the ignition key switch to the OFF position.
- B. Remove the 70 pin Breakout T and reconnect the P20 MIC.
- C. Disconnect the P1 ECM connector from the ECM and connect a 70 pin Breakout T.
- D. Connect the electronic service tool to the diagnostic connector.
- E. Turn the keyswitch to the ON position.
- F. Insert a jumper wire between J1:43 on the Breakout T. Monitor the status screen on the electronic service tool. Slowly connect and disconnect the other end of the jumper wire to socket 69 NEG battery on the Breakout T.

Expected Result:

When the jumper wire is connected the status of the relay should be closed.

When the jumper wire is disconnected the status of the relay should be open.

Results:

- OK – Proceed to Test Step 6.
- Not OK – The problem is in the wire harness between the MIC and the ECM connector.

Repair: Repair the damaged wire or replace the wire. Verify that the problem has been eliminated.

If the repair has not eliminated the problem proceed to test step 6.

STOP.

Test Step 6. Override the Air Inlet Heater Starting Aid in order to Test the ECM

- A. Turn the ignition key switch to the OFF position.
- B. Remove the 70 pin Breakout T.
- C. Connect the P1 ECM connector.
- D. Connect the electronic service tool to the diagnostic connector.
- E. Turn the keyswitch to the ON position.
- F. Use the electronic service tool to monitor the status screen.
- G. Use the override parameter for the air inlet heater starting aid to override the following systems:
 - Glow plug starting aid (if equipped)
 - Fuelled starting aid (if equipped)
- H. Verify that the air inlet heater starting aid is either “enabled” or “disabled”.
- I. Verify that the lamp for the air inlet heater starting aid is on.

Expected Result:

The air inlet heater starting aid is working properly.

Results:

- OK – The ECM is operating properly. STOP.
- Not OK – The ECM is not working properly.

Repair: Temporarily connect a test ECM. Remove all jumpers and replace all connectors. The test ECM should be programmed with the correct software. All parameters should be set to the same value of the suspect ECM.

If the problem is eliminated with the test ECM, reconnect the suspect ECM. If the problem returns with the suspect ECM, replace the suspect ECM.

Verify that the repair has eliminated the problem.

STOP.

i02270219

Analog Throttle Position Sensor Circuit - Test

The system will check the switch position in relation to the throttle position signal when the idle validation has been set for use. If the switch position and the signal from the throttle demand sensor are valid then the throttle will operate as normal.

System Operation Description:

Use this procedure if another procedure has directed you here. Use this procedure if any of the following diagnostic codes are active:

- 91-02 Throttle Demand Sensor erratic or intermittent
- 91-03 Throttle Demand Sensor open circuit or shorted high
- 91-04 Throttle Demand Sensor shorted low
- 774-02 Throttle Demand Sensor No.2 erratic or intermittent
- 774-03 Throttle Demand Sensor No.2 open circuit or shorted high
- 774-04 Throttle Demand Sensor No.2 shorted low
- 262-03 5V Sensor Supply Voltage more than normal
- 262-04 5V Sensor Supply Voltage less than normal

The throttle demand sensor is an Analog sensor and this sensor is mounted on the throttle pedal. The throttle demand sensor provides an output voltage to the ECM. This sensor output voltage will vary with the position of the throttle from 0.5 volts to 4.5 volts. The throttle demand sensor is attached directly to the throttle assembly. Foot or hand operated versions of the throttle assembly are also available.

The sensor receives +5 volt power from the ECM. The sensor will produce a voltage that will alter between low idle and high idle. The voltage is changed into a throttle position within the range 0 to 100 percent by the ECM.

The throttle demand sensor senses the speed requirement from the throttle position. A second throttle demand sensor may override this speed requirement from the first throttle demand sensor. This override will be subject to an input from either the SAE J1939 (CAN), or from the Set Speed Control. The input status can be checked on the electronic service tool Status Display Screen.

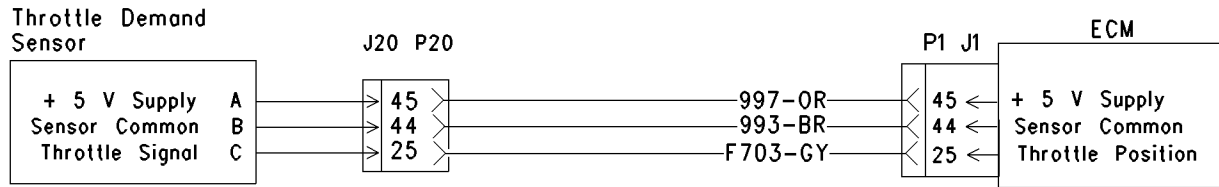

Illustration 28

g00955292

Schematic of the analog throttle demand sensor

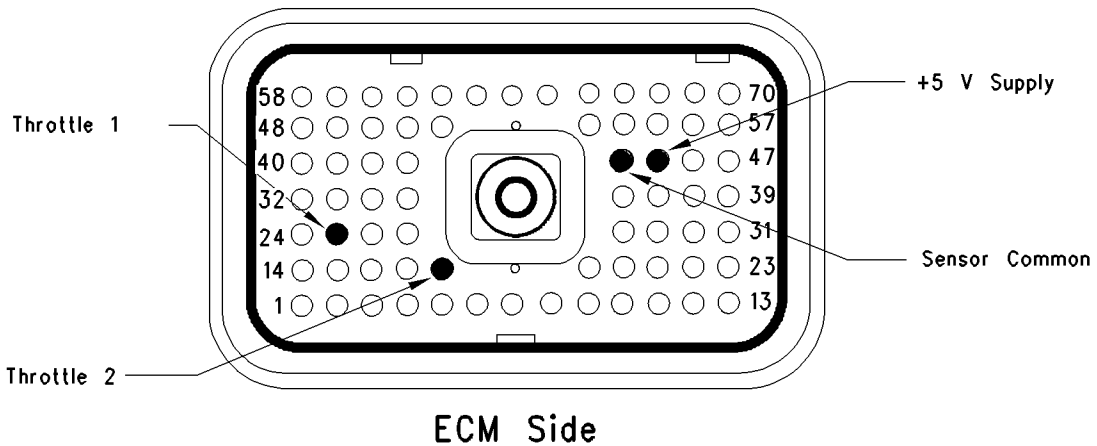

Illustration 29

g00997597

ECM pin locations

Test Step 1. Check for Connector Damage.

- A. Turn the keyswitch to the OFF position.
- B. Check the connectors and wiring for the following problems: damage, abrasion, corrosion, and incorrect attachment.

- C. Refer to Troubleshooting, "Electrical Connectors - Inspect".

- D. Perform a 45 N (10 lb) pull test on each of the wires in the harness that are associated with the throttle demand sensor. Check the wire connectors at the ECM, at the MIC, and at the throttle pedal.

- P1:18 Throttle No 2
- P1:25 Throttle No 1
- P1:44 Sensor common
- P1:45 +5V DC sensor supply

E. Check the ECM connector (Allen head screw) for the proper torque of 6.0 N·m (55 lb in).

Expected Result:

The connectors and wiring should be free of the following problems: damage, abrasion, corrosion, and incorrect attachment.

Results:

- OK – Proceed to Test Step 2.
- Not OK

Repair: Repair the connectors or wiring and/or replace the connectors or wiring.

STOP.

Test Step 2. Check for active Diagnostic Codes.

- A. Turn the keyswitch to the ON position.
- B. Use the electronic service tool to check for diagnostic codes.

Expected Result:

RESULT 1 The electronic service tool displays the following active diagnostic codes:

- 91-03
- 91-04
- 774-03
- 774-04

RESULT 2 The electronic service tool displays the following active diagnostic codes:

- 91-12
- 774-12
- 262-03
- 262-04

RESULT 3 The electronic service tool displays the following active diagnostic codes:

- 91-02
- 774-02

RESULT 4 The electronic service tool displays no active diagnostic codes:

Results:

- Result 1 – Proceed to Test Step 3.
- Result 2 – Proceed to Test Step 5.
- Result 3

Repair: Refer to Troubleshooting, “Idle Validation Circuit Test”.

STOP.

- Result 4 – Proceed to Test Step 3.

Test Step 3. Check the Throttle Position with the Electronic Service Tool.

- A. Connect the electronic service tool to the diagnostic connector.
- B. Turn the keyswitch to the ON position. The engine should be off.
- C. Observe the throttle position reading on the electronic service tool.
- D. Depress the throttle and release the throttle.

Expected Result:

The output should increase when the throttle pedal is depressed.

The output should be between “20 percent” and “27 percent” at the low idle position. The output should be between “80 percent” and “87 percent” at the high idle position.

Results:

- OK – The throttle demand sensor is operating correctly. Proceed to Test Step 5.
- Not OK – The ECM is not receiving a correct signal from the sensor. There may be a problem in the harness. Proceed to Test Step 4.

Test Step 4. Check the Voltage at the Throttle Demand Sensor.

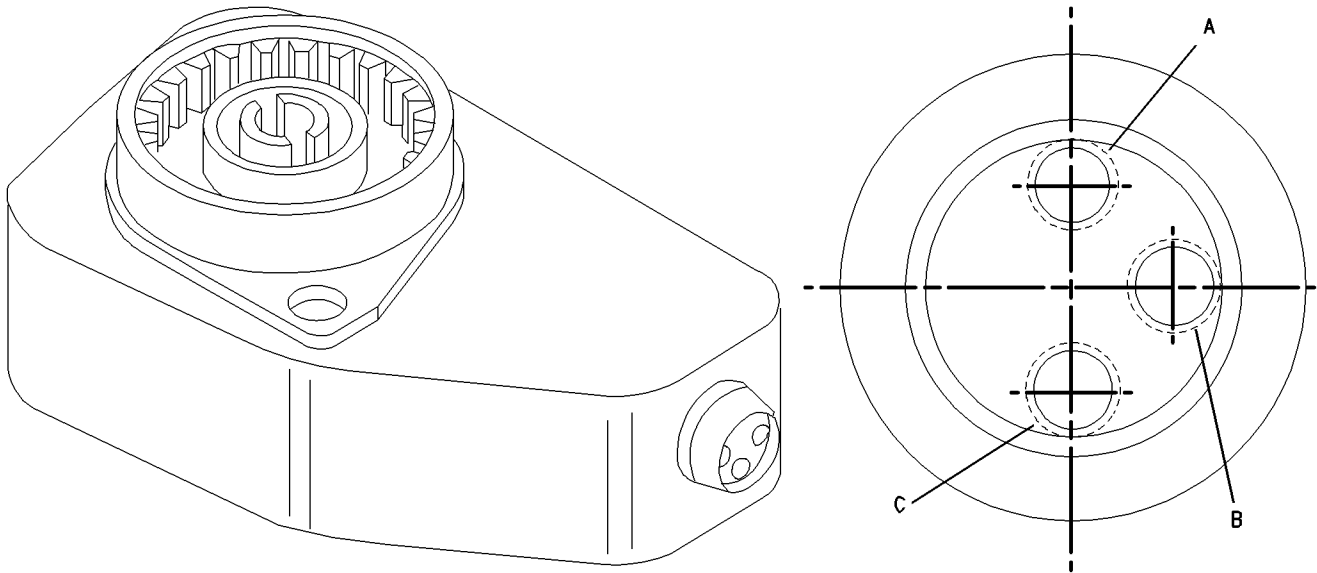

Illustration 30

g00835148

Typical example of the throttle demand sensor for the 1106 and 1104 engines

- A. Turn the keyswitch to the OFF position.
- B. Install a Breakout T with 3 terminals for this test procedure.
- C. Turn the keyswitch to the ON position.
- D. Measure the voltage between terminal A and terminal B.

Expected Result:

Supply voltage should be between 4.5 VDC and 5.5 VDC.

Results:

- OK – The supply voltage is reaching the sensor. Proceed to Test Step 5.
- Not OK – Proceed to Test Step 6.

Test Step 5. Disconnect the Throttle Position Sensor and Check for Active Diagnostic Codes.

- A. Turn the keyswitch to the OFF position. Use the electronic service tool to check for active diagnostic codes.
- B. Ensure that one of the following diagnostic codes are active:
 - 262-03 5 Volt Sensor Power Supply voltage more than normal

- 262-04 5 Volt Sensor Power Supply voltage less than normal

- C. While the throttle demand sensor is connected and disconnected, monitor the electronic service tool screen. Check and record active diagnostic codes.

Expected Result:

Diagnostic codes are active after disconnecting the throttle sensor.

Diagnostic codes are not active after disconnecting the throttle sensor.

Results:

- OK – Diagnostic codes are not active after disconnecting the throttle demand sensor. Reconnect the throttle sensor and proceed to test step 7.
- Not OK

Repair: Temporarily install another throttle demand sensor. Use the electronic service tool in order to check if the diagnostic codes are still active. Replace the throttle demand sensor if both of the following conditions occur:

- The problem is corrected with the new throttle demand sensor.

- The problem returns after the old throttle demand sensor has been reconnected.

STOP.

Test Step 6. Check the Throttle Selection Status with the Electronic Service Tool.

- A.** Check the status of the throttle selection switch (if equipped). The throttle selection status can be observed on the status display screen of the electronic service tool.

Expected Result:

If the throttle selection switch status is shown in the OFF position, then the throttle 1 has control of the engine speed.

If the throttle selection switch status is shown in the ON position then the throttle 2 has control of the engine speed.

The throttle could be overridden by instructions via the SAE J1939 (CAN) or the set speed control.

Results:

- OK – The throttle demand switch is operating correctly.

Repair: There may be an intermittent fault. Refer to Troubleshooting, “Electrical Connectors - Inspect”.

STOP.

- Not OK – The wrong throttle is selected. Change to the other throttle. There may be a fault with the input from the selector switch. Proceed to Step 7.

Test Step 7. Disconnect the Supply Terminals of the Throttle Demand Sensor at the ECM.

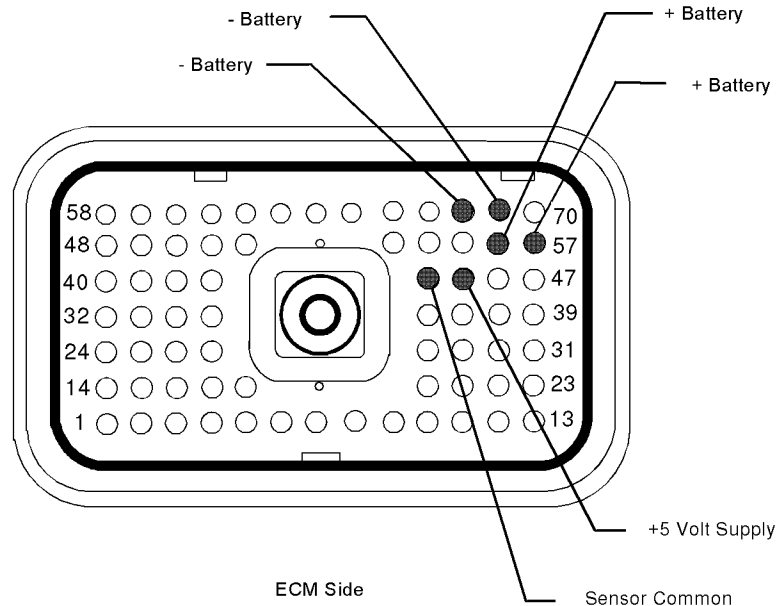

Illustration 31

g01137361

Connections for the ECM terminals

- A. Turn the keyswitch to the OFF position.
- B. Remove P:45 (+5 volt supply) and P:44 (sensor common) from the ECM connector P1.
- C. Turn the keyswitch to the ON position.
- D. Use the electronic service tool to check for active diagnostic codes.

Expected Result:

The ECM is not working correctly.

The cable between the ECM and the throttle demand sensor is faulty.

Results:

- OK – Check for proper battery voltage.

Repair: Check the battery voltage for P1 between terminal 56 and terminal 57 to terminal 68 and terminal 69. The voltage should be between 11.0 to 13.5 volts for a 12 volt system. The voltage should be between 22.0 to 27.0 volts for a 24 volt system. If the battery voltage is correct and diagnostic codes are still active, then the ECM does not operate correctly.

1. Temporarily connect a test ECM.

Note: The test ECM should be programmed with the correct software. All parameters should be set to the same value as the suspect ECM.

2. If the fault is eliminated with the test ECM, reconnect the suspect ECM.
3. If the fault returns with the suspect ECM, then the suspect ECM is faulty.
4. Replace the suspect ECM.

STOP.

- Not OK – There is a short circuit in the harness or connectors.

Repair: Connect the cables one at a time. Connect terminal 44 to the ECM. Check if the diagnostic code reappears. Then connect terminal 45 to the ECM. Use the electronic service tool to check if the diagnostic code reappears. Replace the faulty cable. Verify that the repair has eliminated the fault.

STOP.

Test Step 8. Check the Position of Throttle Demand Sensor.

- A.** Turn the keyswitch to the OFF position.
- B.** Install a Breakout T with 3 terminals to the throttle demand sensor.
- C.** Turn the keyswitch to the ON position.
- D.** Measure the voltage between terminal C and terminal B of the Breakout T.
- E.** Observe the voltage while the engine speed control is moved from the minimum to the maximum position.

Expected Result:

The voltage should be between 20 and 80 percent of the sensor supply voltage when the speed control is moved from the minimum to the maximum position.

Results:

- OK – The throttle demand sensor is working correctly. Proceed to Test Step 9.
- Not OK – The throttle demand sensor is faulty. Proceed to Test Step 10.

Test Step 9. Check the Throttle Demand Sensor at the ECM.

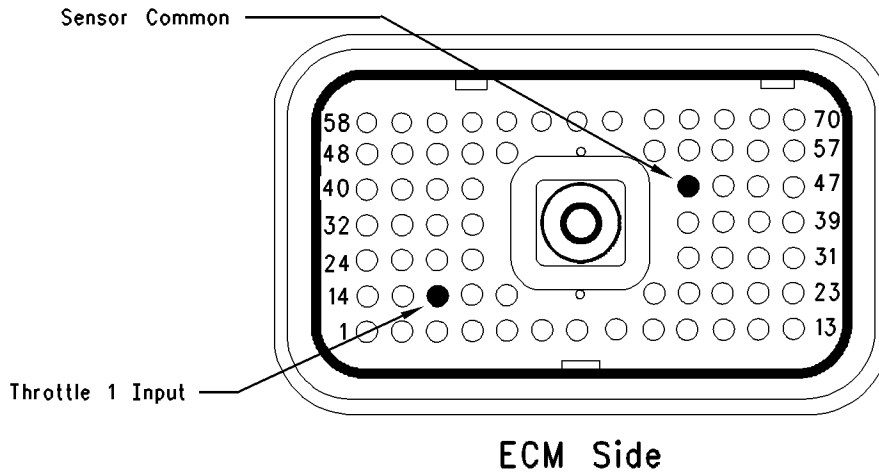

Illustration 32

g00854873

Connections of the ECM terminals

- A. Turn the keyswitch to the OFF position.
- B. Remove terminal 16 from P1.
- C. Connect a multimeter to terminal 16 and terminal 44.
- D. Turn the keyswitch to the ON position.
- E. Use the multimeter to display the output voltage of the throttle demand sensor while the engine speed control is moved from the minimum position to the maximum position.
- F. Turn the keyswitch to the OFF position and connect terminal 16 to the P1 connector.

Expected Result:

The voltage should be between 0 and 100 percent when the speed control is moved from the minimum position to the maximum position.

Results:

- OK – The ECM terminals have the correct voltage for the throttle demand sensor.

Repair: Check for the correct supply voltage at the ECM. If the voltage is correct, then the ECM is suspect.

1. Temporarily connect a test ECM.

Note: The test ECM should be programmed with the correct software. All parameters should be set to the same value of the suspected ECM.

2. If the fault is eliminated with the test ECM, install the suspect ECM and verify that the fault returns.
3. If the fault returns replace the ECM.

STOP.

- Not OK – There is a fault in the harness or the connectors between the sensor and the ECM. Check the terminals between the MIC and the throttle demand sensor. Repair the damaged cables or replace the damaged cables. Check that the repairs have eliminated the fault. STOP.

Test Step 10. Remove the Throttle Demand Sensor from the Engine Speed Control Assembly.

- A Mate sensor to accelerator pedal assembly. Key must match up with the sensor slot. Check the sensor housing for a flush fit to the pedal assembly mounting surface (This ensures slot on sensor has mated correctly with the pedal assembly key.)
- B Ensure the sensor is oriented the same as it was prior to removal to ensure sensor harness pigtail is routed correctly.
- C Line up screw holes and install mounting screws.

NOTE: Procedure is identical for the suspended accelerator pedal assembly.

Accelerator Pedal Assembly

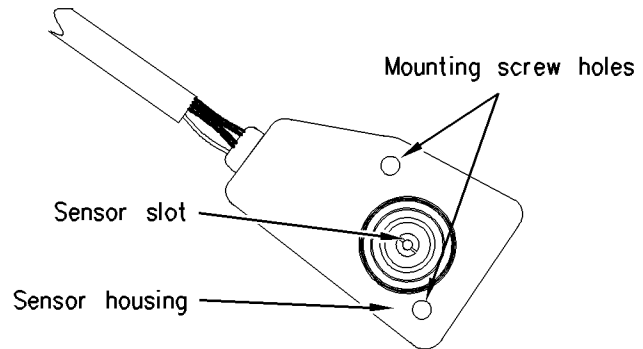
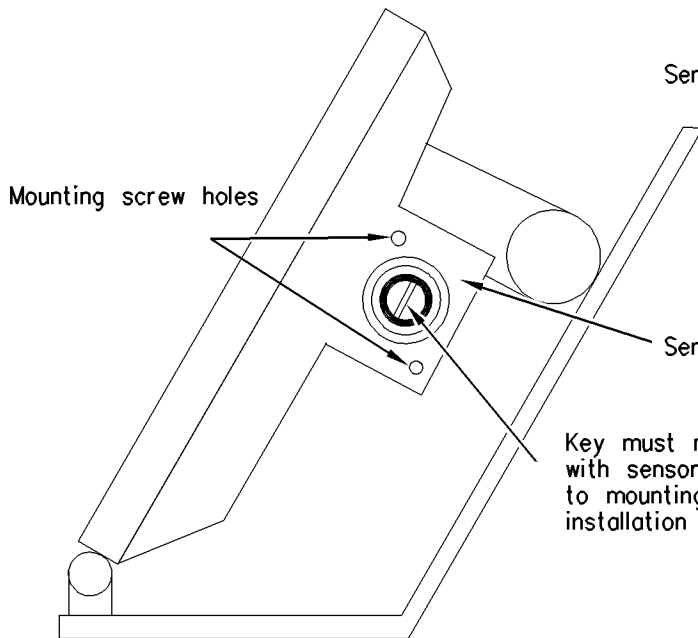

Accelerator Block Assembly

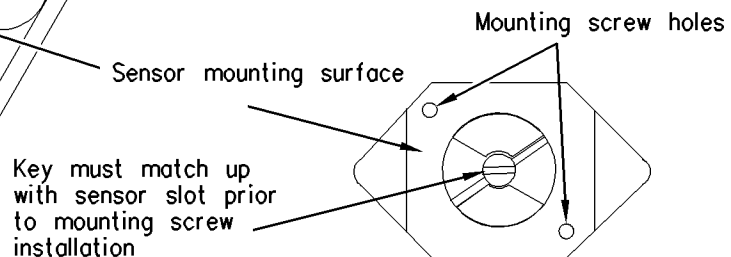

Accelerator Block Assembly

Illustration 33
Accelerator pedal assembly

g00706977

- A. Turn the keyswitch to the OFF position.
- B. Record the position of the sensor before removing the throttle demand sensor.
- C. Remove the throttle demand sensor from the housing and inspect the cables for signs of wear.
- D. Connect a multimeter to terminal C and terminal B of the Breakout T.
- E. Turn the keyswitch to the ON position.

- F. Record the signal voltage of the throttle demand sensor with the sensor slot in the released position.
- G. Record the signal voltage of the throttle demand sensor with the sensor slot in the advanced position.

Expected Result:

The output from the throttle demand sensor is 0.5 volts or less with the sensor slot in the released position.

The output from the throttle demand sensor is 4.5 volts or more with the sensor slot in the advanced position.

Results:

- OK

Repair: The operation of the throttle demand sensor is correct. The fault is caused by the foot pedal or the lever assembly. Adjust the assembly or replace the assembly.

Verify that the repairs have eliminated the fault.

STOP.

- Not OK – The throttle demand sensor is faulty.

Repair: Replace the throttle demand sensor.

Verify that the repair has eliminated the fault.

STOP.

i01798197

CAN Data Link Circuit - Test

System Operation Description:

Use this procedure if another procedure has directed you here. Also use this procedure if any of the following diagnostic codes are active:

- 342-2 Speed and Timing Sensor No.2 intermittent signal

The CAN Data Link is the communication link between the Electronic Control Module (ECM) and the fuel injection pump. The CAN Data Link is used to communicate the following information:

- Engine timing
- Fuel demand to the fuel injection pump
- Data from the fuel injection pump
- Status of the fuel injection pump

A failure in the CAN Data Link will cause the following conditions:

- The engine will shut down.
- The engine will not start.

Note: Do not attempt to repair the wire harness between the ECM and the fuel injection pump. If the wire harness is damaged the wire harness must be replaced.

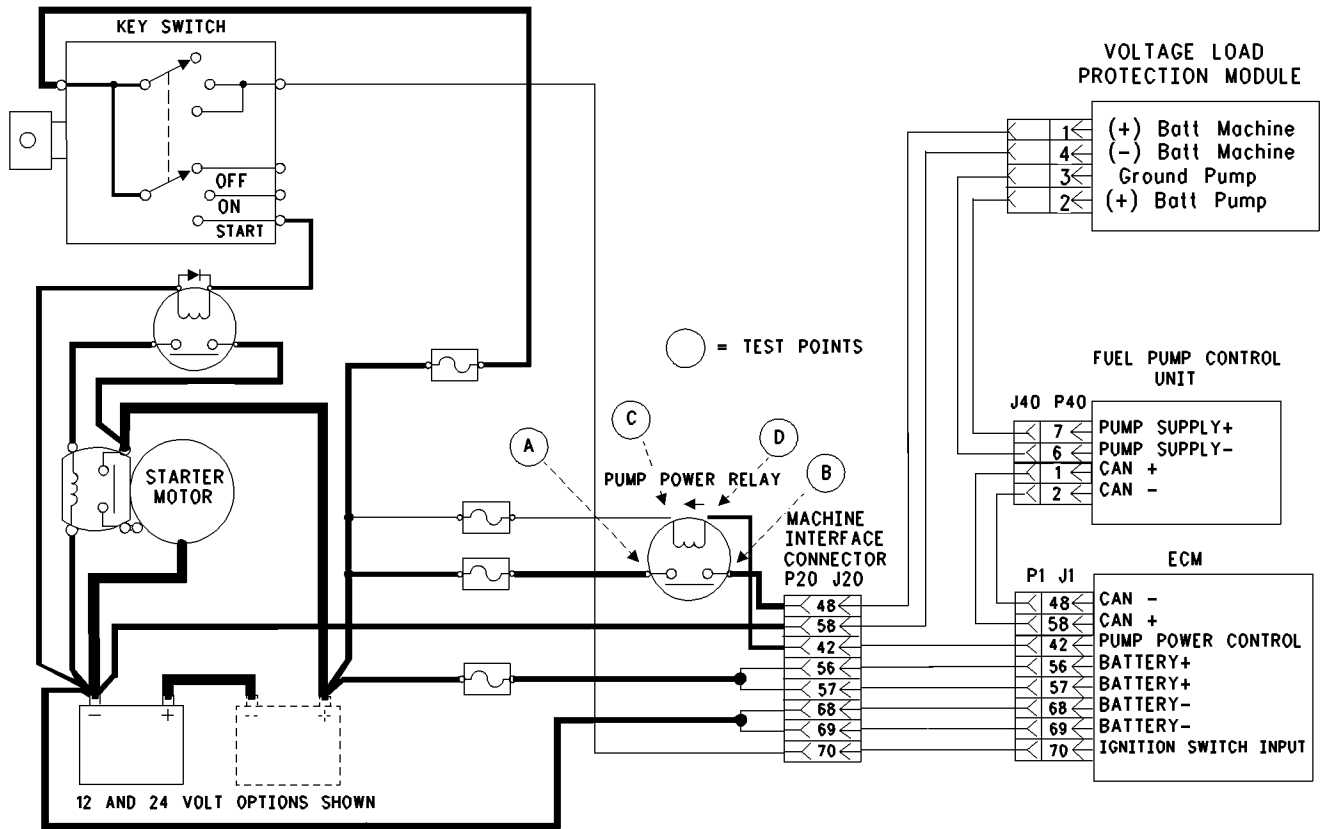

Illustration 34
 Schematic for the CAN Data Link and the fuel injection pump

Test Step 1. Inspect Electrical Connectors and Wiring

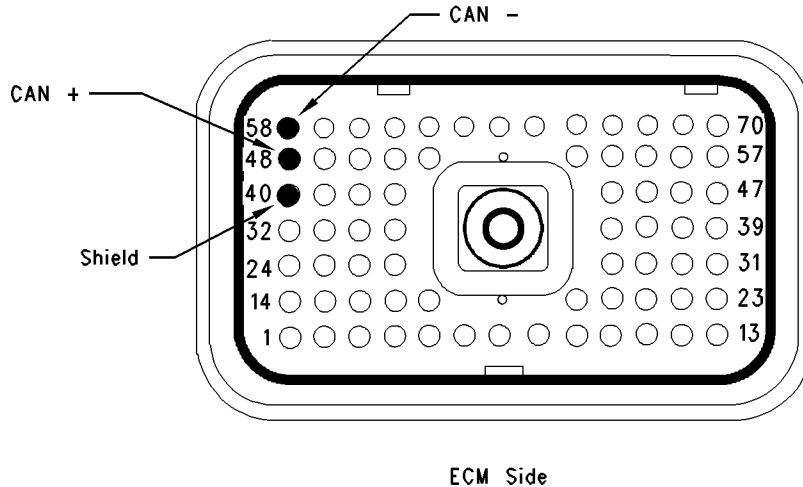

Illustration 35

g00885803

- A.** Turn the keyswitch to the OFF position.
- B.** Check the connectors and wiring for the following problems: damage, corrosion, abrasion, and incorrect attachment.
- C.** Pay close attention to the following areas:
- ECM connector J1/P1
 - P1:48 CAN +
 - P1:58 CAN -
 - P40:2 CAN +
 - P40:1 CAN -
 - P1:40 Shield

Refer to Troubleshooting, "Electrical Connectors - Inspect" for more information.

Expected Result:

The connectors and wiring should be free of the following problems: damage, corrosion, abrasion, and incorrect attachment.

Results:

- OK – Proceed to Test Step 2.
- Not OK

Repair: Repair the Data Link circuit. Replace the cables and/or the connectors that are causing the problem. Ensure that all seals are properly placed and that all connectors are secured correctly. Verify that the repair eliminates the problem.

Proceed to 2.

Test Step 2. Check the CAN Data Link Between the ECM and P40 Fuel Injection

Pump Control Unit Connector for an Open Circuit

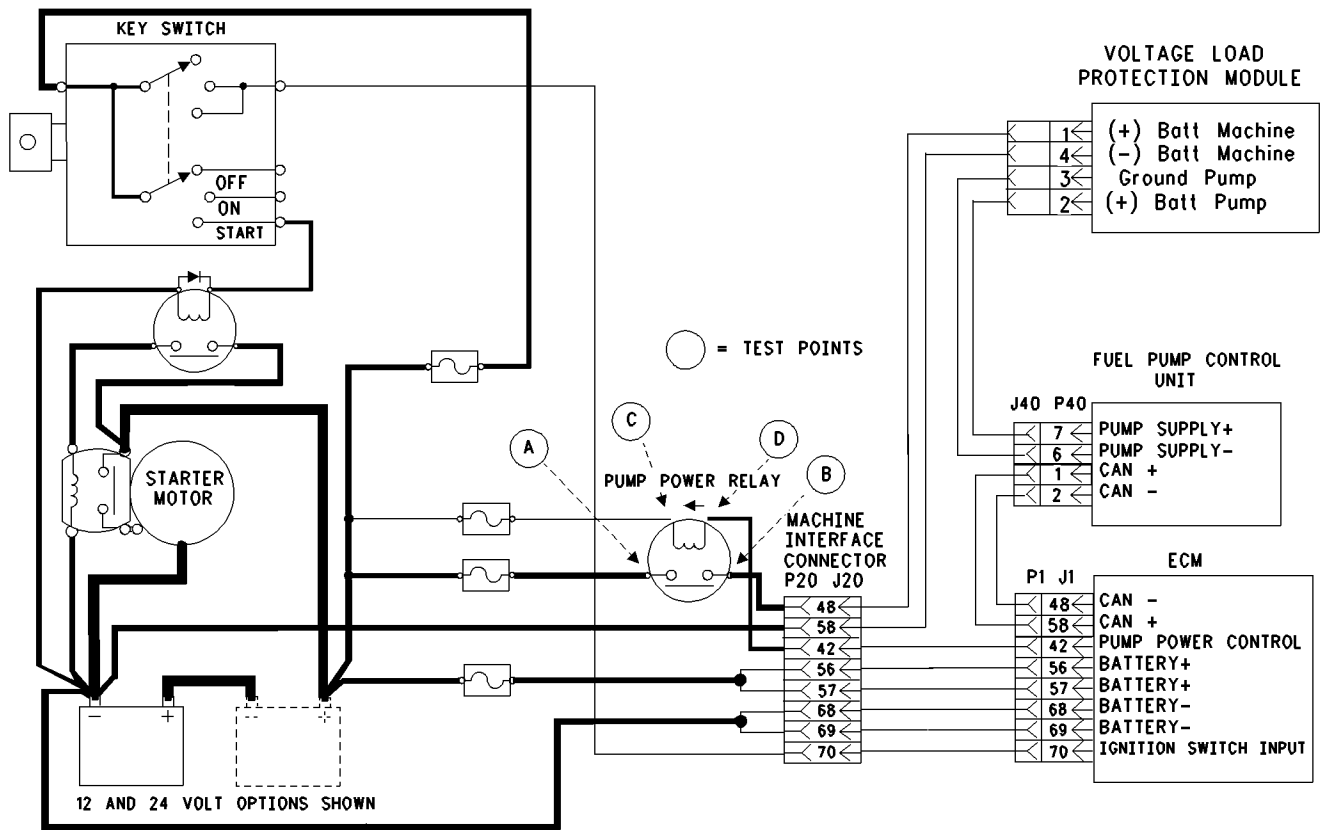

Illustration 36
 Schematic of the CAN Data Link and the fuel injection pump

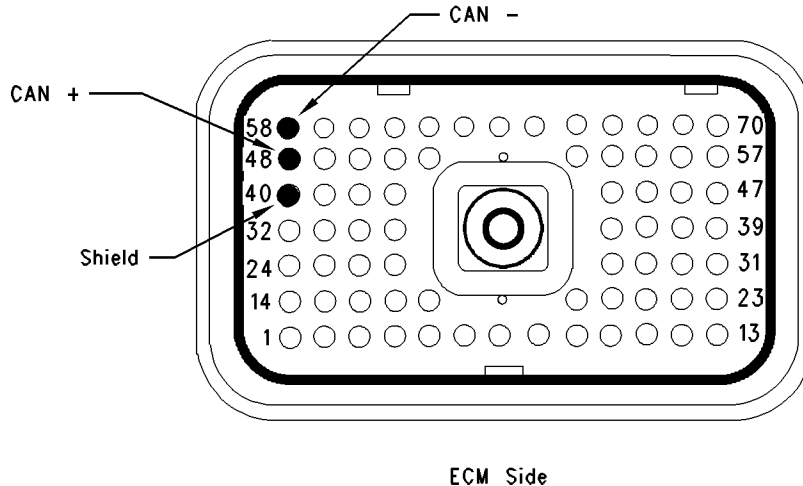

Illustration 37

g00885803

A. Disconnect P1 from the ECM.

Note: Do not disconnect P40 Fuel Injection Pump Connector.

B. Measure the resistance between terminal P1:48 and terminal P1:58.

Expected Result:

The readings should be between 100 and 132 ohms.

Results:

- OK – Proceed to Test Step 3.
- Not OK

Repair: There is an open circuit in the harness between the P1 ECM connector and the control unit for the fuel injection pump. Repair the harness and/or replace the harness.

STOP.

Test Step 3. Check the CAN Data Link Between the ECM and P40 Fuel Injection Pump Control Unit Connector for a Short Circuit

A. Disconnect P1 from the ECM.

Note: Do not disconnect P40 Fuel Injection Pump Connector.

B. Measure the resistance between terminal P1:58 and terminal P1:40.

C. Measure the resistance between terminal P1:48 and terminal P1:40.

Expected Result:

The readings should be more than 5,000 ohms.

Results:

- OK – Proceed to Test Step 4.
- Not OK

Repair: There is a short circuit in the harness between the P1 ECM connector and the control unit for the fuel injection pump. Repair the harness and/or replace the harness.

STOP.

Test Step 4. Verify the Supply Voltage at the Fuel Injection Pump

A. Turn the keyswitch to the OFF position.

B. Disconnect the P40 connector from the fuel injection pump.

- C. Turn the keyswitch to the ON position.
- D. Measure the voltage between terminal J40:7 and terminal J40:6.
- E. Turn the keyswitch to the OFF position.
- F. Reconnect the P40 connector.

Expected Result:

The voltage for a 12 V system should be constant. The voltage should be between 11.0 volts and 13.5 volts.

The voltage for a 24 volt system should be constant. The voltage should be between 22.0 volts and 27.0 volts.

Results:

- OK

Repair: Perform the following repairs:

1. Temporarily connect a test ECM.

Note: The test ECM should be programmed with the correct software. All parameters should be set to the same value as the suspect ECM.

2. If the fault is eliminated with the test ECM, reconnect the suspect ECM.
3. If the fault returns with the suspect ECM, then the suspect ECM is faulty. Replace the suspect ECM.

STOP.

- Not OK – No voltage or the voltage is less than the permissible limit.

Repair: Refer to Troubleshooting, “Fuel Injection Pump Circuit - Test”.

Verify that the repair has eliminated the fault.

STOP.

Use this procedure if the electronic service tool will not communicate with the Electronic Control Module (ECM) through the data link. If the electronic service tool will not power up, refer to Troubleshooting, “Electrical Power Supply Circuit - Test”.

Use this test if the Engine Monitoring System (EMS) displays “Error” or incorrect values are being displayed. An incorrect value may be “0” for engine speed.

The following background information is related to this procedure:

The Data Link is the standard Data Link that is used by the ECM in order to communicate with the electronic service tool.

The ECM provides the following two connections for the Data Link from the ECM connector J1:

- J1:5 (Data Link Negative) to J20:5
- J1:4 (Data Link Positive) to J20:4

Communication

The electronic service tool may indicate the following error message:

- The version of the ECM is not recognized and the integrity of the changed parameters and displayed data is not guaranteed.

This message will indicate that the version of the software that is in the electronic service tool is not the same version of the software that is in the ECM. Contact the Perkins Technical Service Centre in order to confirm the correct version of the software.

i01798198

Data Link Circuit - Test

System Operation Description:

Use this procedure under the following circumstances:

Test Step 1. Inspect Electrical Connectors and Wiring.

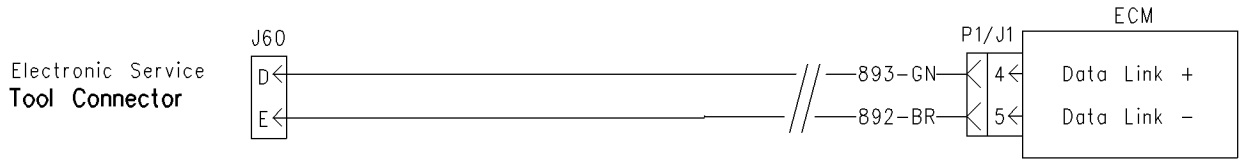

Illustration 38
Schematic for the Data Link

g00954759

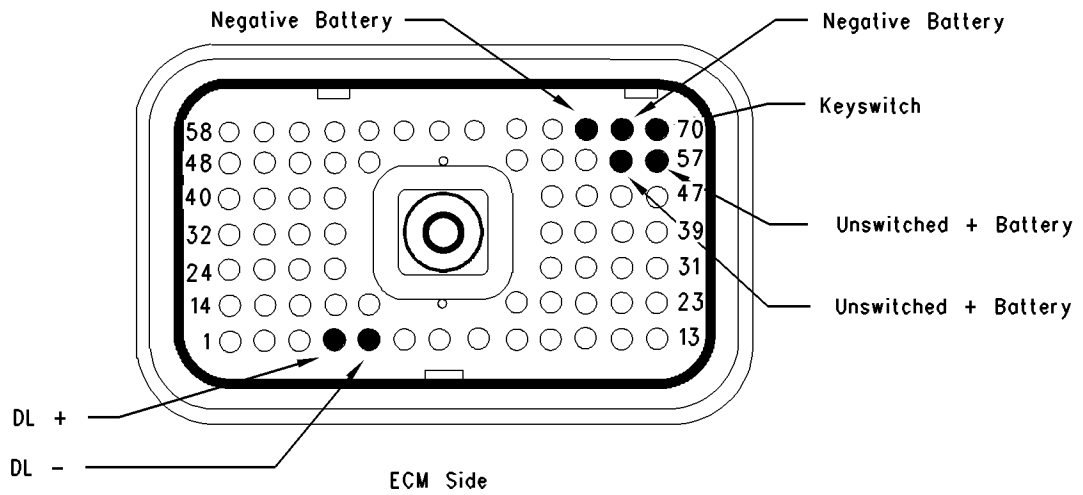

Illustration 39
ECM pin locations

g00954765

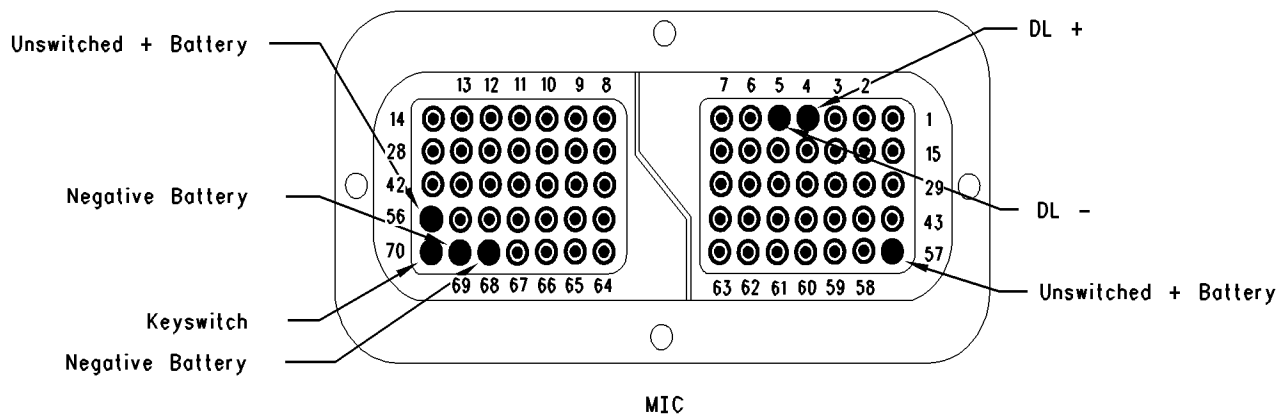

Illustration 40
MIC pin locations

g00954767

A. Thoroughly inspect the following electrical connectors:

- ECM connector J1/P1
- Data Link connectors J60 and J20/P20
- J20 Customer connector (pin 4 and pin 5)
- Electronic Service Tool connectors
- Data Link (terminal 4 and terminal 5) in the J1/P1 ECM connector

Refer to Troubleshooting, “Electrical Connectors - Inspect” for details.

B. Perform a 45 N (10 lb) pull test on each of the wires in the ECM connector that are associated with the Data Link.

C. Check the ECM connector (Allen head screw) for the proper torque of 6.0 N·m (55 lb in).

D. Check the harness and wiring for abrasion and pinch points from the connector to the ECM.

Refer to Illustration 40.

Expected Result:

All connectors, pins and sockets should be completely coupled and/or inserted. The harness and wiring should be free of corrosion, abrasion and/or pinch points.

Results:

- OK – Proceed to Test Step 2.
- Not OK

Repair: Perform the following repair:

Repair the connectors and/or wiring, or replace the connectors and/or wiring. Ensure that all of the seals are properly in place and ensure that the connectors are completely coupled.

Verify that the repair eliminates the problem.

STOP.

Test Step 2. Determine the type of Problem with the Data Link.

A. Connect the electronic service tool to the J60 service tool connector that is on the engine harness.

B. Start the engine.

Expected Result:

Result 1 The engine starts. The electronic service tool powers up and the electronic service tool communicates without error.

Result 2 The engine starts. The electronic service tool powers up but an error is displayed.

Result 3 The engine cranks but the engine will not start regardless of the condition of the electronic service tool.

Result 4 The engine will not crank regardless of the condition of the electronic service tool.

Result 5 The engine starts but the electronic service tool does not power up.

Results:

- Result 1 – There is not a problem with the Data Link at this time. If an intermittent condition exists, thoroughly inspect all wiring and connectors.

Repair: Perform the following diagnostic procedure:

Troubleshooting, “Electrical Connectors - Inspect”

STOP.

- Result 2 – The electronic service tool displays an error message. The ECM is receiving battery power. Proceed to Test Step 3.

- Result 3 –

Repair: Perform the following diagnostic procedure:

Troubleshooting, “Engine Will Not Crank”

STOP.

- Result 4 –

Repair: Perform the following diagnostic procedure:

Troubleshooting, “Engine Cranks But Will Not Start”

STOP.

- Result 5 – The electronic service tool does not power up or the communications adapter does not power up. Ensure that the ECM is receiving the correct battery power. Proceed to Test Step 4.

Test Step 3. Check the Battery Voltage at the ECM.

- A. Ensure that the electronic service tool is connected to the J60 service tool connector.
- B. Disconnect ECM connector P1 from ECM connector J1.
- C. Turn the keyswitch to the ON position.

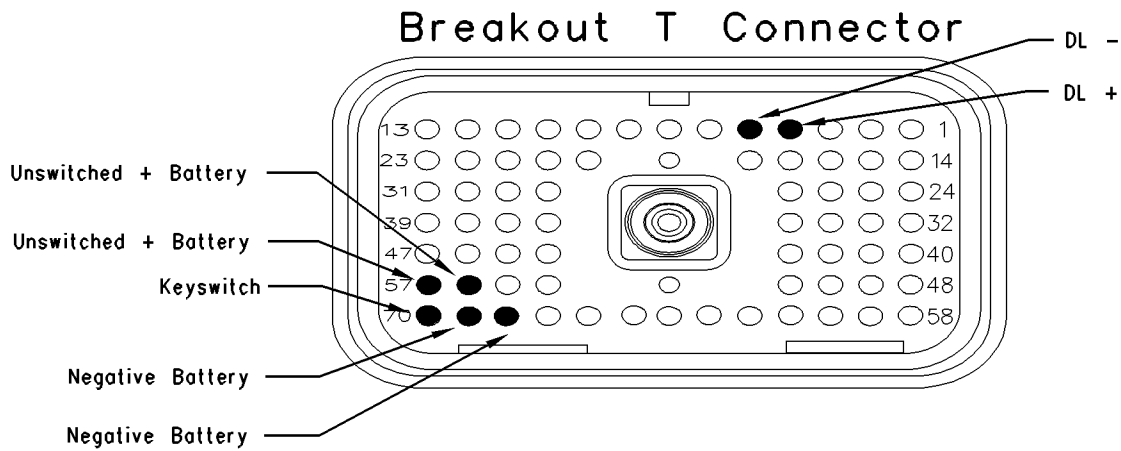

Illustration 41

g00954771

- D. Measure the voltage on P1 between sockets P1:56 (UNSWITCHED POSITIVE BATTERY) and P1:68 (NEGATIVE BATTERY).
- E. Measure the voltage on P1 between sockets P1:57 (UNSWITCHED POSITIVE BATTERY) and P1:69 (NEGATIVE BATTERY).
- F. Measure the voltage on P1 between sockets P1:70 (keyswitch) and P1:68 (NEGATIVE BATTERY).

Refer to Illustration 39.

Expected Result:

The voltage is between 22.0 VDC and 27 VDC for a 24 volt system and between 11.0 VDC and 13.5 VDC for a 12 volt system when the keyswitch is in the ON position.

Results:

- Yes – The ECM is currently receiving the correct voltage. Proceed to Test Step 4.
- No – The ECM is not receiving the correct voltage.

Repair: Perform the following diagnostic procedure:

Troubleshooting, “Electrical Power Supply Circuit - Test”

STOP.

Test Step 4. Check the Battery Voltage that is coming to the Data Link Connector.

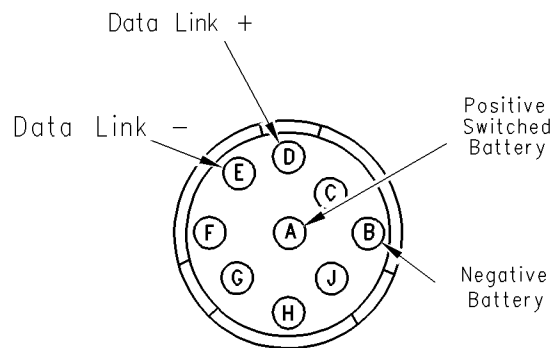

Deutsch 9-Pin Service Tool Connector

Illustration 42

g00954774

- A.** Turn the keyswitch to the ON position.
- B.** Use a multimeter in order to measure the voltage between the pin A POSITIVE SWITCHED BATTERY and pin B for NEGATIVE BATTERY on the service tool connector.

Refer to Illustration 42.

Expected Result:

The voltage is between 22.0 VDC and 27.0 VDC for a 24 volt system and between 11.0 VDC and 13.5 VDC for a 12 volt system.

Results:

- Yes – The Data Link connector is currently receiving the correct voltage. Proceed to Test Step 5.
- No – The Data Link connector is not receiving the correct voltage.

Repair: Inspect the wiring and fuses to the connector. Repair the wiring or batteries and/or replace the wiring or batteries, as required. Send the machine to the OEM dealer for repair, if necessary.

Verify that the repair eliminates the problem.

STOP.

Test Step 5. Connect the Electronic Service Tool directly to the ECM.

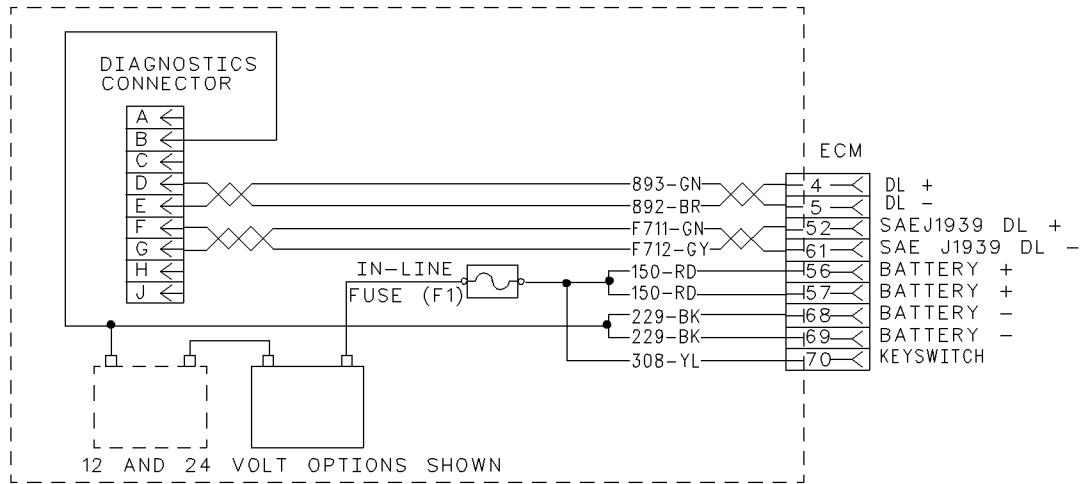

Illustration 43
 Typical bypass harness

g00954776

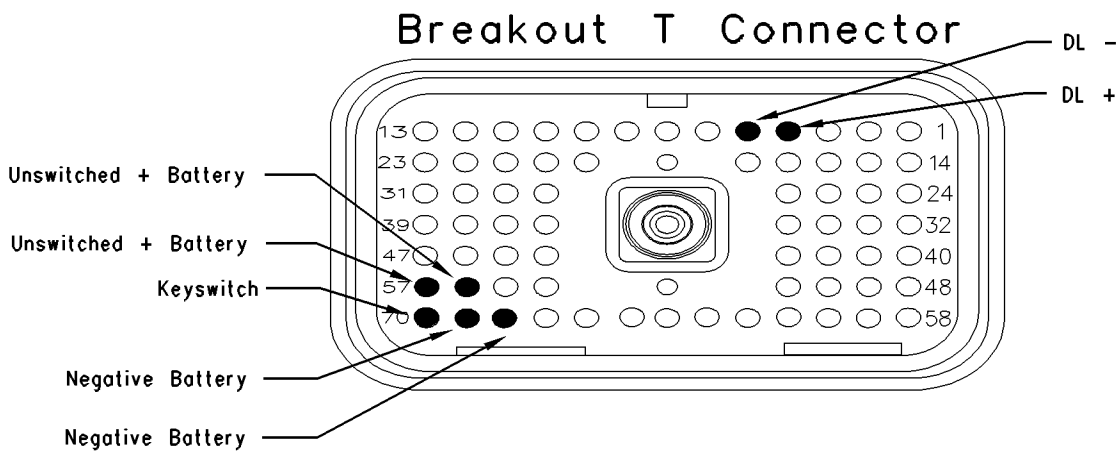

Illustration 44
 Pin locations for the Breakout T

g00954771

⚠ WARNING

Batteries give off flammable fumes which can explode.

To avoid injury or death, do not strike a match, cause a spark, or smoke in the vicinity of a battery.

NOTICE

Do Not connect the Bypass Harness to the battery until the 20 Amp in-line fuse has been removed from the +Battery line. If the fuse is not removed before connection to the battery a spark may result.

- A. Turn the keyswitch to the ON position.
- B. Disconnect engine harness connector J1/P1 from the ECM.
- C. Construct a bypass harness for the electronic service tool. Connect the bypass harness to ECM connector J1.

Refer to Illustration 43 for the bypass harness.

Note: This bypass directly connects the circuit for the keyswitch to the ECM. The ECM will remain powered until the connection to the unswitched battery line “+” is disconnected. Remove the 20 Amp fuse from the in-line fuse holder to power down the ECM. Do Not connect the bypass to the battery posts without first removing the 20 Amp in-line fuse or do not remove the bypass from the battery posts without first removing the 20 Amp in-line fuse.

Expected Result:

The electronic service tool is operating correctly.

Results:

- Yes

Repair: Perform the following repair:

There is a problem in the wiring. Inspect the wiring and fuses to the connector. Repair the wiring and/or batteries, or replace the wiring and/or batteries, as required.

Verify that the repair eliminates the problem.

STOP.

- No – Verify that the 20 Amp fuse in the bypass harness of the electronic service tool is not open. A fuse that is open is a blown fuse. Proceed to Test Step 6.

Test Step 6. Change Electronic Service Tool Components.

- A. If another electronic engine is available, connect the electronic service tool to the other engine. Ensure that the same cables are used.
- B. Turn the keyswitch to the ON position. Determine if the electronic service tool operates correctly on the other engine.
- C. If another engine is not available in the shop, find a different set of electronic service tool cables. Ensure that the set of electronic service tool cables is a complete set.
- D. Use the new set of cables and connect the electronic service tool to the Data Link connector.
- E. Turn the keyswitch to the ON position.
- F. If changing cables allows the electronic service tool to operate properly, use the following procedure:
 - a. Replace the pieces from the old set of cables into the new set of cables that operate. Replace one piece at a time.
 - b. Apply power to the electronic service tool after each of the pieces is replaced. Use this method to find the faulty piece.
- G. If changing cables does not allow the electronic service tool to operate properly, connect another electronic service tool.
- H. Turn the keyswitch to the ON position.

Expected Result:

Result 1 The original electronic service tool works on another engine.

Result 2 A different electronic service tool works on the original engine while the engine is being tested.

Results:

- Result 1 – Proceed to Test Step 7.
- Result 2

Repair: Send the faulty electronic service tool for repairs.

STOP.

Test Step 7. Connect an Electronic Service Tool and the ECM to another Battery.

WARNING

Batteries give off flammable fumes which can explode.

To avoid injury or death, do not strike a match, cause a spark, or smoke in the vicinity of a battery.

NOTICE

Do Not connect the Bypass Harness to the battery until the 20 Amp in-line fuse has been removed from the +Battery line. If the fuse is not removed before connection to the battery a spark may result.

- A. Connect the battery wires from the bypass harness of the electronic service tool to a different battery that is not on the engine.

Expected Result:

The electronic service tool is operating correctly.

Results:

- Yes

Repair: Perform the following diagnostic procedure:

Troubleshooting, "Electrical Power Supply Circuit - Test"

STOP.

- No

Repair: Perform the following repair:

1. Temporarily connect a test ECM.

Note: The test ECM should be programmed with the correct software. All parameters should be set to the same value as the suspect ECM.

2. Remove all jumpers and reconnect all connectors.
3. Recheck the system for active diagnostic codes.
4. Repeat the test step.
5. If the problem is resolved with the test ECM, reconnect the suspect ECM.

6. If the problem returns with the suspect ECM, replace the suspect ECM.

7. Verify that the repair eliminates the problem.

STOP.

i02293740

Digital Throttle Position Sensor Circuit - Test

System Operation Description:

Use this procedure if another procedure has directed you here. Use this procedure if any of the following diagnostic codes are active:

- 91-08 Throttle Demand Sensor abnormal signal
- 774-08 Throttle Demand Sensor No.2 abnormal signal
- 41-03 8 Volt Sensor Power Supply, voltage more than normal
- 41-04 8 Volt Sensor Power Supply, voltage less than normal

The pedal mounted throttle position sensor provides a throttle position signal to the Electronic Control Module (ECM). The pedal mounted throttle position sensor is attached directly to the throttle assembly. Foot or hand operated versions of the throttle assembly are available.

The pedal mounted throttle position sensor will produce a duty cycle of 10 to 22 percent at low idle and 75 to 90 percent when the accelerator pedal is fully depressed.

The pedal mounted throttle position sensor will produce a minimum duty cycle when the pedal is released. The pedal mounted throttle position sensor will produce a maximum duty cycle when the pedal is fully depressed.

The pedal mounted throttle position sensor sends a pulse width modulated signal. The signal varies with the throttle position. The signal is expressed as a percentage.

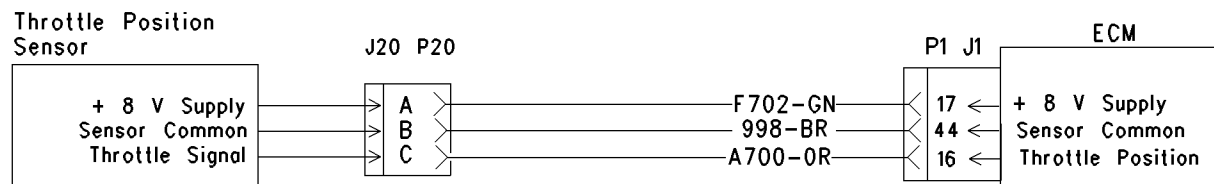

Illustration 45

Schematic of the throttle position sensor

g00872561

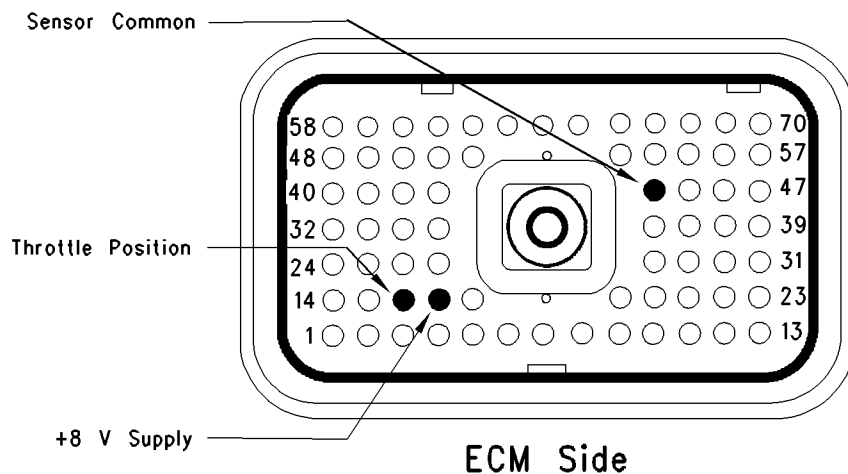

Illustration 46

ECM pin locations

g00872608

Test Step 1. Check for Connector Damage.

- A. Turn the keyswitch to the OFF position.
- B. Check the connectors and wiring for the following problems: damage, abrasion, corrosion, and incorrect attachment.

C. Refer to Troubleshooting, "Electrical Connectors - Inspect".

- D. Perform a 45 N (10 lb) pull test on each of the wires in the ECM connector that are associated with the pedal mounted throttle position sensor:

- P1:16

- P1:17
- P1:44

E. Check the ECM connector (Allen Head Screw) for the proper torque of 6.0 N·m (55 lb in).

Expected Result:

The connectors and wiring should be free of the following problems: damage, abrasion, corrosion, and incorrect attachment.

Results:

- OK – Proceed to Test Step 2.
- Not OK

Repair: Repair the connectors or wiring and/or replace the connectors or wiring.

STOP.

Test Step 2. Check for active Diagnostic Codes.

- A.** Turn the keyswitch to the ON position.
- B.** Use the electronic service tool to check for diagnostic codes.

Expected Result:

RESULT 1 The electronic service tool displays the following active diagnostic codes:

- 91-08
- 774-08

RESULT 2 The electronic service tool displays the following active diagnostic codes:

- 41-03
- 41-04

RESULT 3 The electronic service tool displays no active diagnostic codes.

Results:

- Result 1 – Proceed to Test Step 3.
- Result 2 – Proceed to Test Step 5.
- Result 3 – Proceed to Test Step 3.

Test Step 3. Check the Throttle Position with the Electronic Service Tool.

- A.** Connect the electronic service tool to the service tool connector.
- B.** Turn the keyswitch to the ON position. The engine should be OFF.
- C.** Observe the throttle position reading on the electronic service tool.
- D.** Depress the throttle and release the throttle.

Expected Result:

The output should be “0 percent” when the pedal is released. The output should increase to “100 percent” when the throttle pedal is fully depressed.

The output should be between “20 percent” and “27 percent” at the low idle position. The output should be between “80 percent” and “87 percent ” at the high idle position.

Results:

- OK – The throttle position sensor is operating correctly. Proceed to Test Step 5.
- Not OK – The ECM is not receiving a correct signal from the sensor. There may be a problem in the harness. Proceed to Test Step 4.

Test Step 4. Check the Voltage at the Throttle Position Sensor.

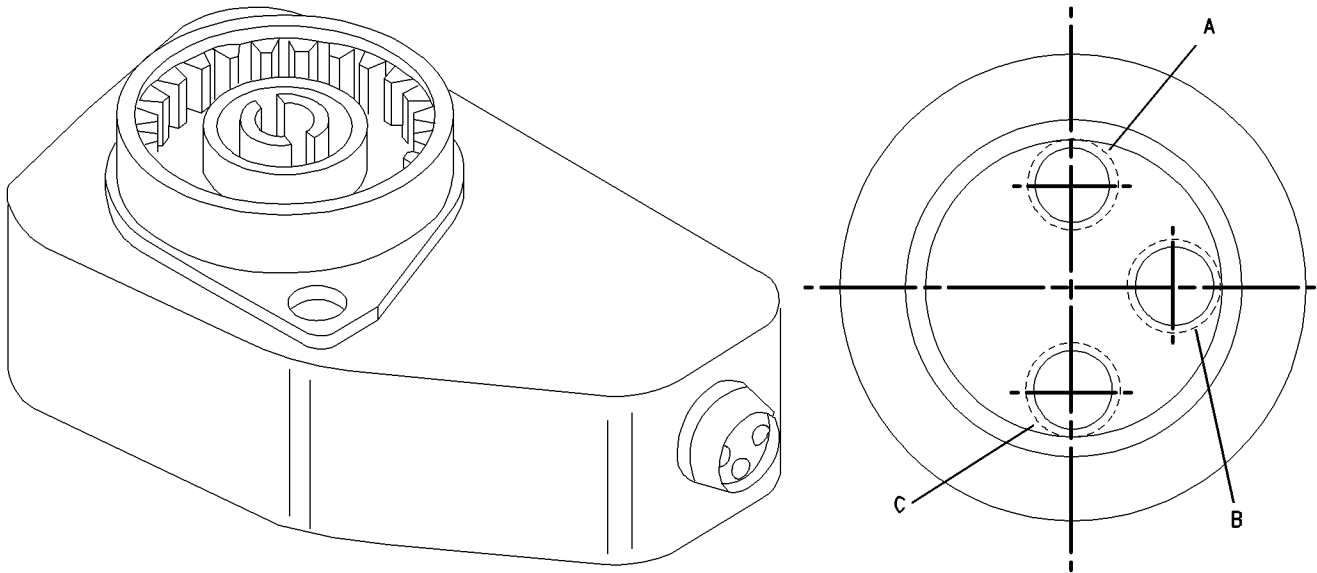

Illustration 47

g00835148

Typical example of the throttle position sensor for the 1104 and 1106 engines

- A. Turn the keyswitch to the OFF position.
 - B. Install a Breakout T with 3 terminals for this test procedure.
 - C. Turn the keyswitch to the ON position.
 - D. Measure the voltage between terminal A and terminal B.
- 41-04 8 Volt Sensor Power Supply, voltage less than normal
- C. While the throttle position sensor is connected and disconnected, monitor the electronic service tool screen. Check and record active diagnostic codes.

Expected Result:

Diagnostic codes are active after disconnecting the throttle sensor.

Diagnostic codes are not active after disconnecting the throttle sensor.

Expected Result:

Supply voltage should be between 7.6 VDC and 8.4 VDC.

Results:

- OK – The supply voltage is reaching the sensor. Proceed to Test Step 5.
- Not OK – Proceed to Test Step 6.

Test Step 5. Disconnect the Throttle Position Sensor and Check for Active Diagnostic Codes.

- A. Turn the keyswitch to the ON position. Use the electronic service tool to check for active diagnostic codes.
- B. Ensure that one of the following diagnostic codes are active:
 - 41-03 8 Volt Sensor Power Supply, voltage more than normal

Results:

- OK – Diagnostic codes are not active after disconnecting the throttle position sensor. Reconnect the throttle sensor and proceed to test step 7.
- Not OK

Repair: Temporarily install another throttle position sensor. Use the electronic service tool in order to check if the diagnostic codes are still active. Replace the throttle position sensor if both of the following conditions occur:

- The problem is corrected with the new throttle position sensor.

- The problem returns after the old throttle position sensor has been reconnected.

STOP.

Test Step 6. Check the Throttle Selection Status with the Electronic Service Tool.

- A.** Check the status of the throttle selection switch (if equipped). The throttle selection status can be observed on the status display screen of the electronic service tool.

Expected Result:

If the throttle selection switch status is shown in the OFF position, then the throttle 1 has control of the engine speed.

If the throttle selection switch status is shown in the ON position then the throttle 2 has control of the engine speed.

The throttle could be overridden by instructions via the SAE J1939 (CAN) or the set speed control.

Results:

- OK – The throttle position sensor is operating correctly.

Repair: There may be an intermittent fault. Refer to Troubleshooting, “Electrical Connectors - Inspect”.

STOP.

- Not OK – The wrong throttle is selected. Change to the other throttle. There may be a fault with the input from the selector switch. Proceed to Step 7.

Test Step 7. Disconnect the Supply Terminals of the Throttle Position Sensor at the ECM.

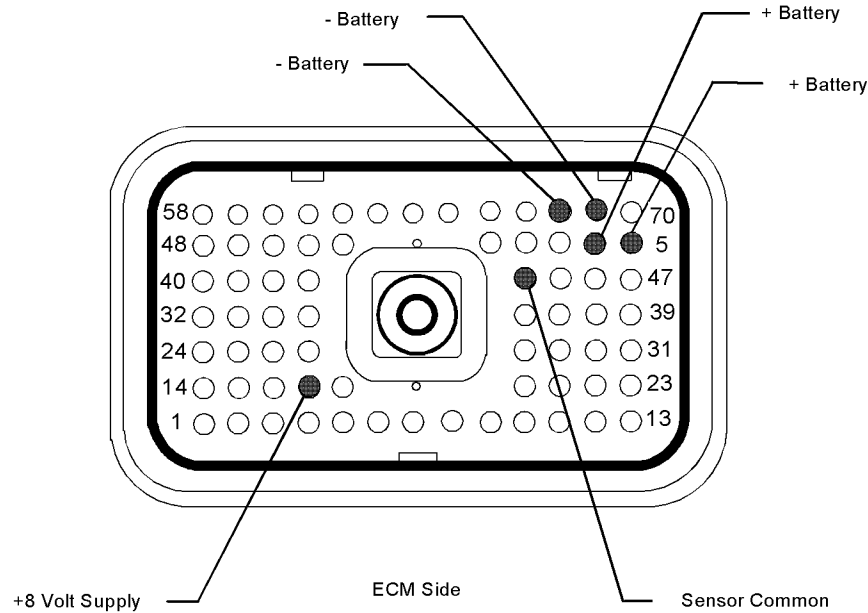

Illustration 48

g01148457

Connections for the ECM terminals

- A. Turn the keyswitch to the OFF position.
- B. Remove P1:17 (+8 volts) and P1:44 (sensor common) from the ECM connector P1.
- C. Turn the keyswitch to the ON position.
- D. Use the electronic service tool to check for active diagnostic codes.

Expected Result:

The ECM is not working correctly.

The cable between the ECM and the throttle position sensor is faulty.

The diagnostic codes are active.

Results:

- OK – Check for proper battery voltage.

Repair: Check the battery voltage for P1 between terminal 56 and terminal 57 to terminal 68 and terminal 69. The voltage should be between 11.0 to 13.5 volts for a 12 volt system. The voltage should be between 22.0 to 27.0 volts for a 24 volt system. If the battery voltage is correct and diagnostic codes are still active, then the ECM does not operate correctly.

1. Temporarily connect a test ECM.

Note: The test ECM should be programmed with the correct software. All parameters should be set to the same value as the suspect ECM.

2. If the fault is eliminated with the test ECM, reconnect the suspect ECM.
3. If the fault returns with the suspect ECM, then the suspect ECM is faulty.
4. Replace the suspect ECM.

The diagnostic codes are no longer active.

STOP.

- Not OK – There is a short circuit in the harness or connectors.

Repair: Connect the cables one at a time. Connect terminal 44 to the ECM. Check if the diagnostic code reappears. Then connect terminal 17 to the ECM. Use the electronic service tool to check if the diagnostic code reappears. Replace the faulty cable. Verify that the repair has eliminated the fault.

STOP.

Test Step 8. Check the Position of Throttle Position Sensor.

- A. Turn the keyswitch to the OFF position.
- B. Install a Breakout T with 3 terminals to the throttle position sensor.
- C. Turn the keyswitch to the ON position.
- D. Measure the PWM signal. Connect one probe to terminal C (throttle position sensor) and the other probe to terminal B sensor common of the Breakout T.
- E. Observe the position while the engine speed control is moved from the minimum to the maximum position.

Expected Result:

The position should be between 10 and 22 percent in the low idle position.

The position should be between 75 and 90 percent in the high idle position.

Results:

- OK – The throttle position is working correctly. Proceed to Test Step 9.
- Not OK – The throttle position sensor is faulty. Proceed to Test Step 10.

Test Step 9. Check the Throttle Position Sensor at the ECM.

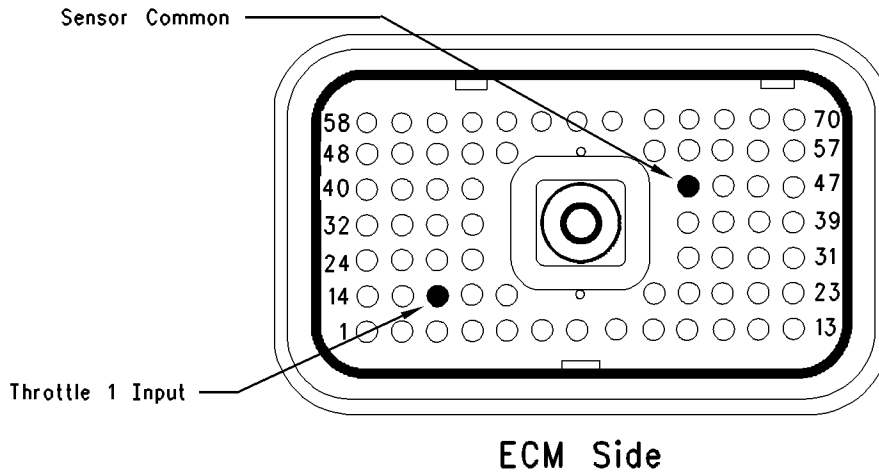

Illustration 49

g00854873

Connections of the ECM terminals

- A. Turn the keyswitch to the OFF position.
- B. Remove terminal 16 from P1.
- C. Connect a multimeter to terminal 16 and terminal 44.
- D. Turn the keyswitch to the ON position.
- E. Use the multimeter to display the output signal of the throttle position sensor while the engine speed control is moved from the minimum position to the maximum position.
- F. Turn the keyswitch to the OFF position and connect terminal 16 to the P1 connector.

Expected Result:

The position should be between 10 and 22 percent in the low idle position.

The position should be between 75 and 90 percent in the high idle position.

Results:

- OK – The ECM terminals have the correct signal for the throttle position sensor.

Repair: Check for the proper supply voltage at the ECM. If the voltage is correct, then the ECM is suspect.

1. Temporarily connect a test ECM.

Note: The test ECM should be programmed with the correct software. All parameters should be set to the same value of the suspect ECM.

2. If the fault is eliminated with the test ECM, install the suspect ECM and verify that the fault returns.
3. If the fault returns replace the suspect ECM.

STOP.

- Not OK – There is a fault in the harness or the connectors between the sensor and the ECM. Check the terminals between the machine interface connector and the throttle position sensor. Repair the damaged cables or replace the damaged cables. Check that the repairs have eliminated the fault. STOP.

Test Step 10. Remove the Throttle Position Sensor from the Engine Speed Control Assembly.

- A Mate sensor to accelerator pedal assembly. Key must match up with the sensor slot. Check the sensor housing for a flush fit to the pedal assembly mounting surface (This ensures slot on sensor has mated correctly with the pedal assembly key.)
- B Ensure the sensor is oriented the same as it was prior to removal to ensure sensor harness pigtail is routed correctly.
- C Line up screw holes and install mounting screws.

NOTE: Procedure is identical for the suspended accelerator pedal assembly.

Accelerator Pedal Assembly

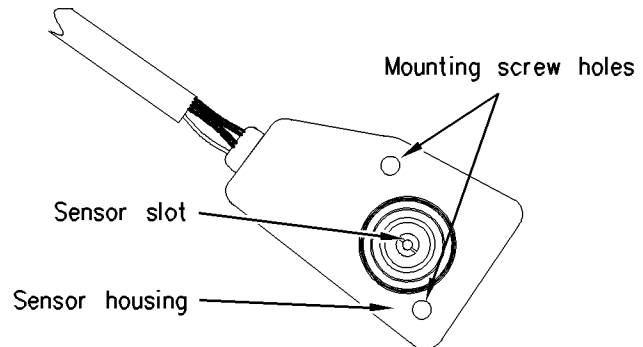
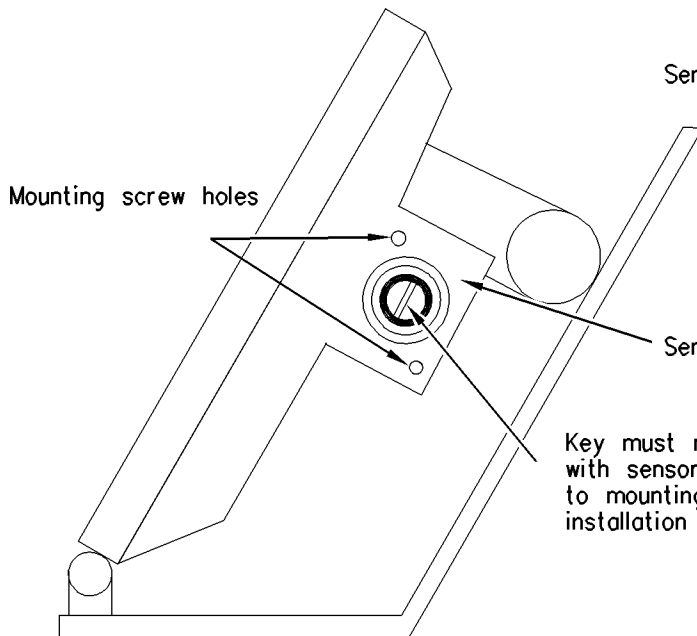

Accelerator Block Assembly

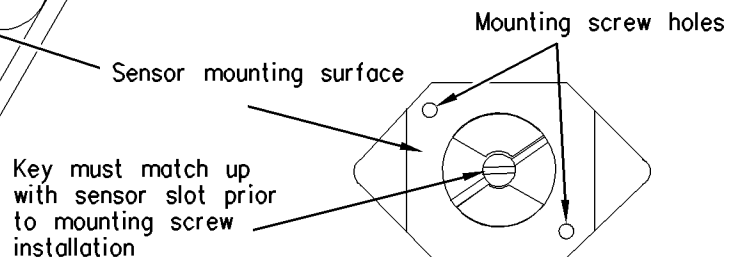

Accelerator Block Assembly

Illustration 50
Accelerator pedal assembly

g00706977

- A. Turn the keyswitch to the OFF position.
- B. Record the position of the sensor before removing the throttle position sensor.
- C. Remove the throttle position sensor from the housing and inspect the cables for signs of wear.
- D. Connect a multimeter to terminal C of the Breakout T.
- E. Turn the keyswitch to the ON position.

- F. Record the output signal of the throttle position sensor with the sensor slot in the released position.
- G. Record the output signal of the throttle position sensor with the sensor slot in the advanced position.

Expected Result:

The throttle position sensor output is 10 percent or less.

The throttle position sensor output is 90 percent or more.

Results:

- OK

Repair: The operation of the throttle position sensor is correct. The fault is caused by the foot pedal or the lever assembly. Adjust the assembly or replace the assembly.

Verify that the repairs have eliminated the fault.

STOP.

- Not OK – The throttle position sensor is faulty.

Repair: Replace the throttle position sensor.

Verify that the repair has eliminated the fault.

STOP.

- Bent terminals
- Improperly crimped terminals
- Corrosion
- Improper harness routing

The original source of the problem must then be identified in order to ensure that the problem does not reoccur.

Follow this procedure to thoroughly inspect the connectors in order to determine if the connectors are the cause of the problem.

i02295092

Electrical Connectors - Inspect

System Operation Description:

Use this procedure in order to check the electrical connectors:

Use the following steps to help determine if the connector is the cause of the problem. If a problem is found in the electrical connector, repair the connector and verify that the problem has been corrected.

The following background information is related to this procedure:

Many of the operational procedures and the diagnostic code procedures in this troubleshooting guide will instruct you to check a specific electrical connector. The engine uses a variety of Deutsch and AMP connectors.

Intermittent electrical problems are often caused by poor connections. Always check for an active diagnostic code before breaking any connections. Also, always check for an active diagnostic code after the connector is reconnected in order to verify that the problem disappears.

Simply disconnecting the connectors and then reconnecting the connectors can temporarily solve a problem at times. If this occurs, check for the following conditions:

- Loose terminals

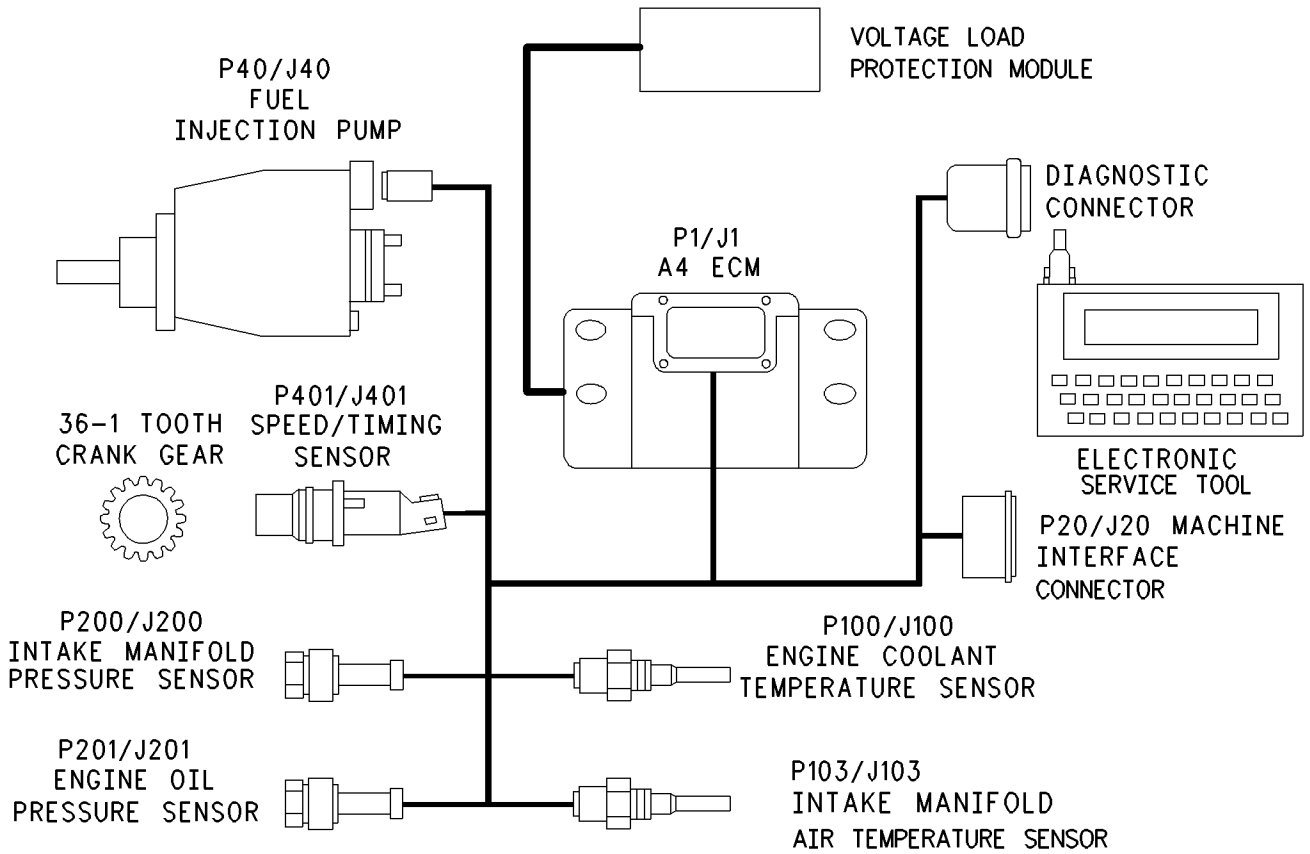

Illustration 51
Basic engine schematic

g00954204

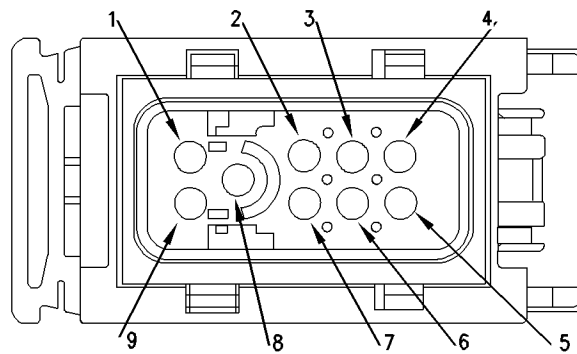

Illustration 52
"VP30" Fuel injection pump connector

g01149572

- | | | |
|---------------------|------------------|---------------|
| (1) Data link | (4) + Battery | (7) Unused |
| (2) Unused | (5) - Battery | (8) Unused |
| (3) Engine position | (6) Fuel shutoff | (9) Data link |

A - WIRE HARNESS SIDE
B - ECM SIDE

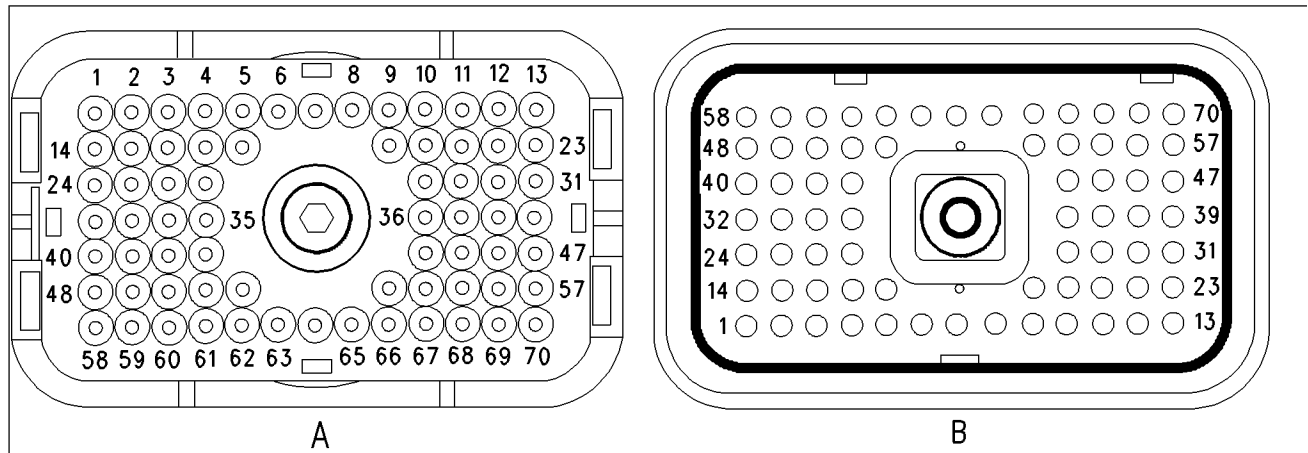

Illustration 53

g00955137

Each end of the Machine SAE J1939 data link must be terminated with a 120 ohm resistor.

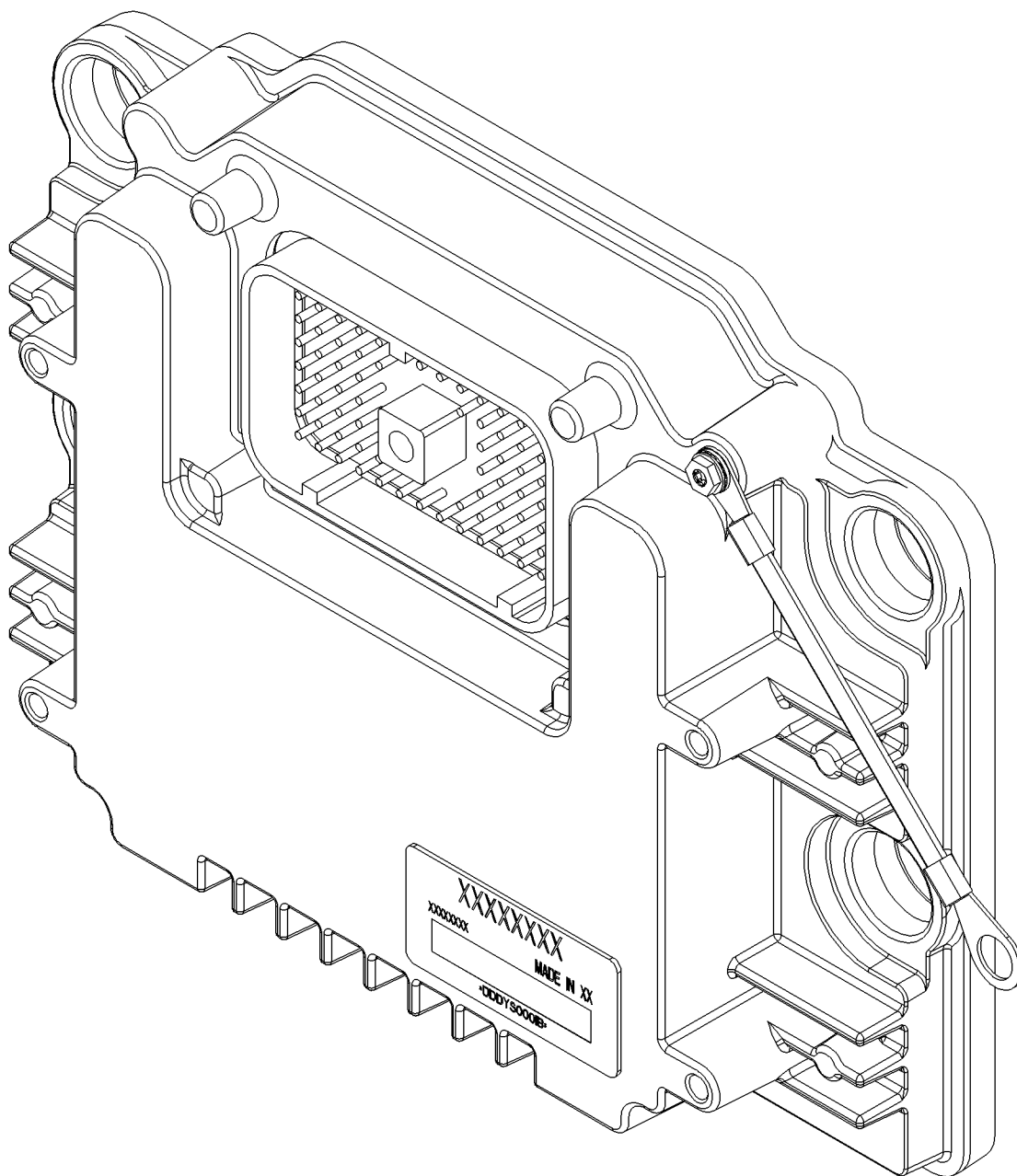

Illustration 54
ECM

Machine Interface Connector (MIC)

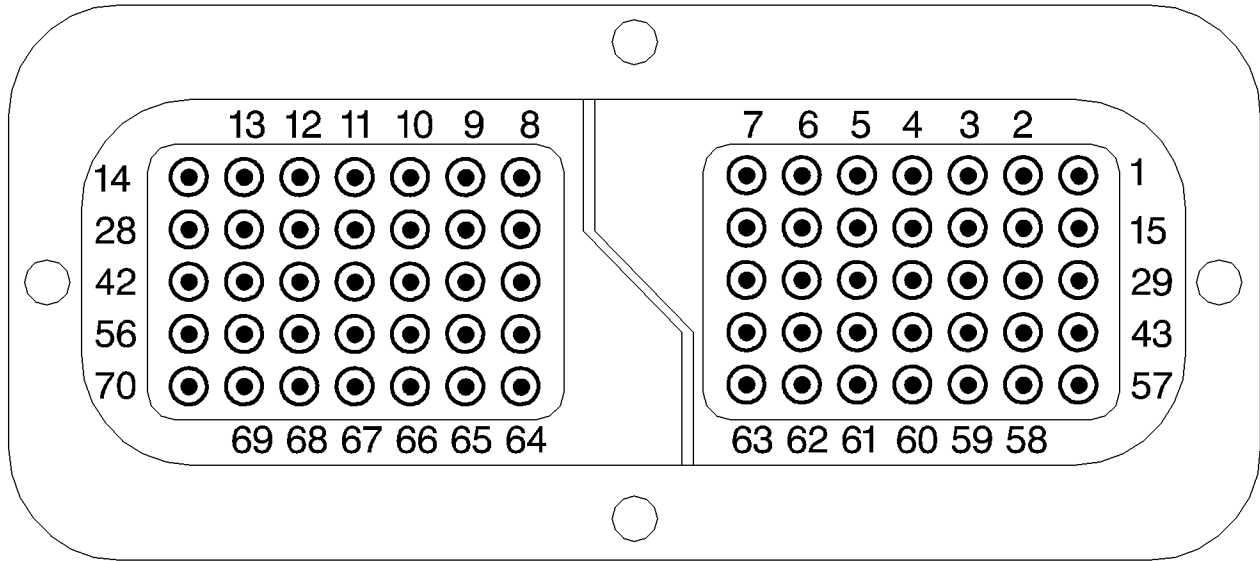

Illustration 55
70 pin Machine Interface Connector.

g00856894

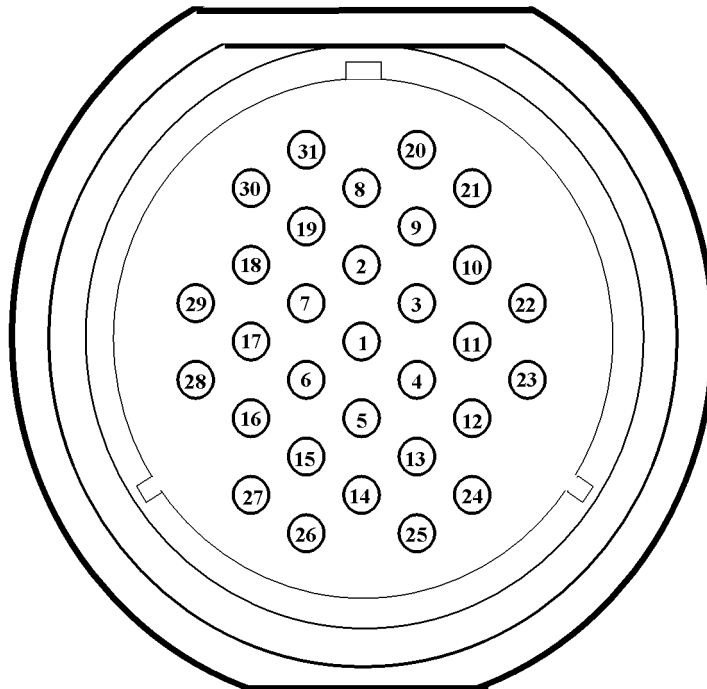

Illustration 56
31 pin Machine Interface Connector.

g01152393

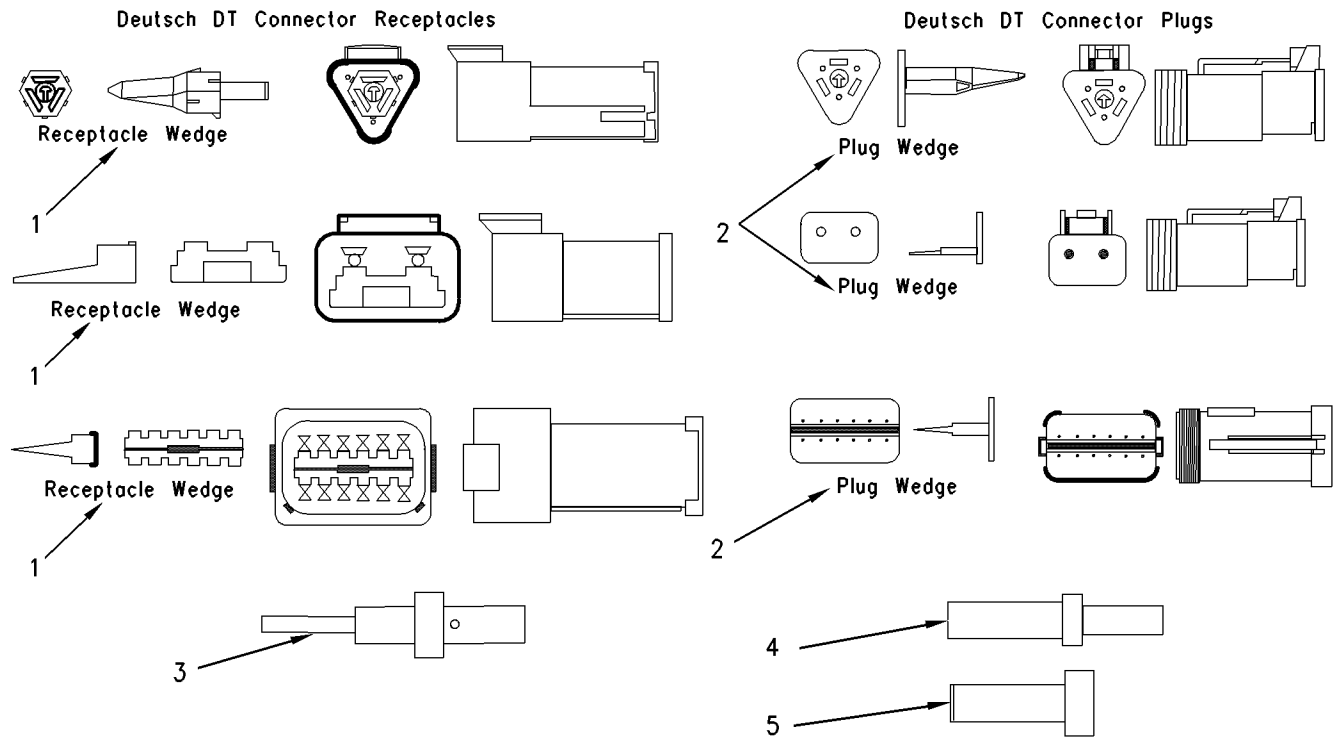

Illustration 57

g00854362

Connector receptacles (Deutsch) and connector plugs (Deutsch)

- (1) Wedge (receptacle)
- (2) Wedge (plug)

- (3) Terminal pin
- (4) Machined socket terminal

- (5) Sealing plug

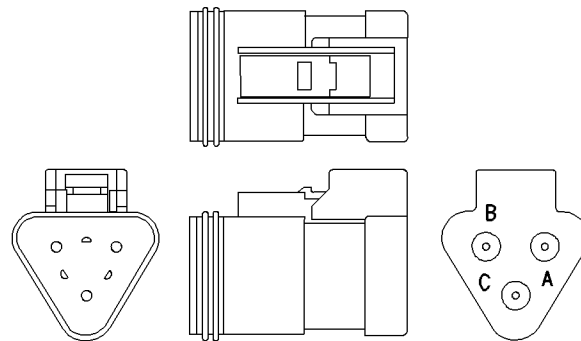

Illustration 58

g00835079

3 pin Deutsch plug connector

- (A) +5 Volt

- (B) Sensor common

- (C) Signal

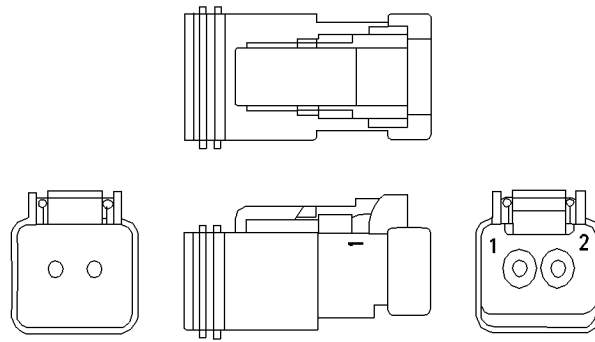

Illustration 59

g00835081

2 pin Deutsch connector

(1) Signal

(2) Sensor common

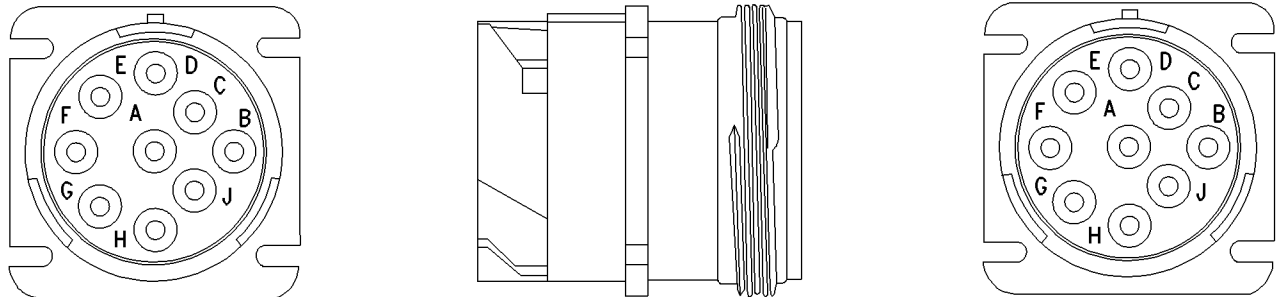

Illustration 60

g00835090

Deutsch data link connector

(A) +Battery

(B) - Battery

(C) J1939 shield

(D) DL+

(E) DL-

(F) J1939 -

(G) J1939 +

(H) Spare

(J) Spare

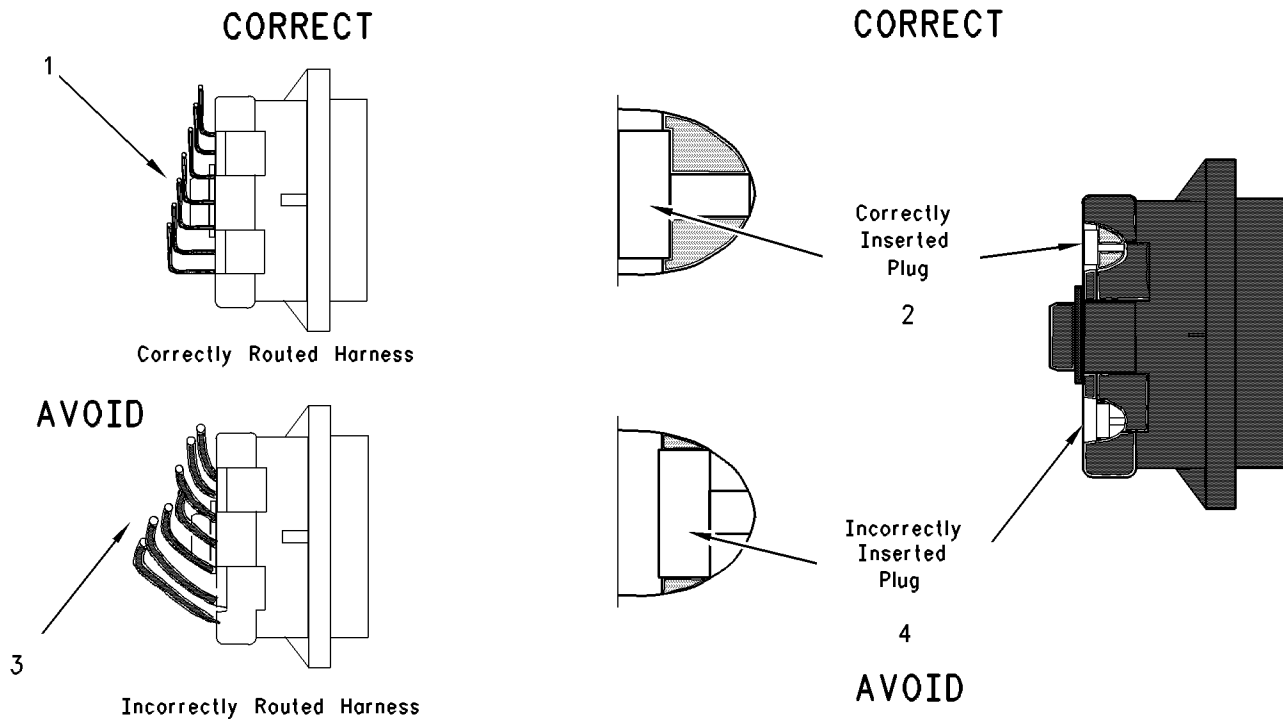

Illustration 61

g00640158

Routing of the harness and insertion of the plug

- (1) Correctly routed harness
 (2) Correctly inserted plug
 (3) Incorrectly routed harness
 (4) Incorrectly inserted plug

Test Step 1. Check the Locking of the DT Connector (Deutsch) and Check the Lock Ring of the HD Style Connector (Deutsch).

- A. Ensure that the connector is properly locked. Also ensure that the two halves of the connector can not be pulled apart.
- B. Verify that the latch tab of the connector is properly latched. Also verify that the latch tab of the connector returns to the Fully Latched position.

Expected Result:

Check that the connector will lock securely. Also check that the connector and the locking mechanism are without cracks or breaks.

Results:

- OK – Proceed to Test Step 2.
- Not OK – Repair the connector or replace the connector, as required.

Repair: Verify that the repair has eliminated the fault.

If the repair has not eliminated the fault, proceed to test step 2.

Test Step 2. Check the Allen Head Screw on the Connector for the Electronic Control Module (ECM)

- A. Ensure that the connector bolt is properly tightened. Be careful not to overtighten the bolt and break the connector.
- B. Do not exceed 6.0 N·m (55 lb in) of torque on the connector bolt of the ECM when the P1/J1 ECM connector is being installed on the ECM.

Expected Result:

The ECM connector is secure and the connector bolt of the ECM is properly torqued.

Results:

- OK – Proceed to Test Step 3.
- Not OK – Secure the ECM connector.

Repair: Tighten the Allen head screw to the proper torque.

Verify that the fault has been eliminated.

If the fault has not been eliminated proceed to test step 3.

Test Step 3. Perform a Pull Test on each Wire Terminal Connection.

- A. Each terminal and each connector should withstand a 45 N (10 lb) pull test. Each wire should remain in the connector body. This test checks whether the wire was properly crimped in the terminal and whether the terminal was properly inserted into the connector.
- B. The DT connectors use an orange wedge to lock the terminals in place.
- C. Check in order to ensure that the orange wedge is not missing and that the orange wedge is installed properly on the DT connectors.

Note: Terminals should always be crimped onto the wires by use of a crimp tool. Do not solder the terminals.

Expected Result:

Check that each terminal and each connector withstands 45 N (10 lb) of pull. Each wire remains in the connector body.

Results:

- OK – Proceed to Test Step 4.
- Not OK – Repair the wiring or replace the connector or the terminal.

Repair: Verify that the repair has eliminated the fault.

If the fault has not been eliminated proceed to test step 4.

Test Step 4. Monitor the Electronic Service Tool while the Wiring and the Connectors are being pulled.

- A. Turn the keyswitch to the ON position.
- B. If there is an inactive diagnostic code that pertains to the circuit, perform the following test:

Monitor the “Inactive Diagnostic Code” screen of the electronic service tool while the diagnostic code remains active. Pull each of the harnesses and the connectors that connect to the component. If the harness is being pulled and the inactive diagnostic code disappears refer to Troubleshooting, “Troubleshooting with a Diagnostic Code” for the correct procedure.

- C. If there is an active diagnostic code on the circuit for a particular component, perform the following test:

Monitor the “Active Diagnostic Code” screen of the electronic service tool for the component while the harnesses are being pulled. Verify that the code has been eliminated. If the code remains active there is a problem in the wiring or the connector.

- D. If there are no active diagnostic codes or inactive diagnostic codes, perform the following test:

Monitor the “Status Display” screen on the electronic service tool for a particular parameter while the wiring harness is being pulled.

If the harness is being pulled and the reading changes erratically, there is a problem in the cables or the connector.

Expected Result:

If the problem appears to be external to the harnesses and connectors, then pulling on the harness and the connectors will have no effect on either the component status of the active diagnostic code or on the engine performance.

Results:

- OK – Proceed to Test Step 5.
- Not OK – Repair the harness and/or the connectors or replace the harness and/or connectors that are causing the problem. If the fault has not been eliminated proceed to test step 5.

Test Step 5. Check Wires for Nicks and/or Abrasions in the Insulation.

- A. Carefully inspect each wire for signs of abrasion, nicks, or cuts.

The following areas are locations that should be checked:

- Exposed insulation
- Points of rubbing wire against the engine
- Points of rubbing wire against a sharp point

B. Check all of the hold down clamps for the harness in order to verify that the harness is properly clamped. Also check all of the hold down clamps for the harness in order to verify that the harness is not compressed by the clamp. Pull back the harness sleeves in order to check for a flattened portion of wire. The flattened portion of wire is caused by the clamp that holds the harness.

Expected Result:

The wires are free of abrasion, nicks, or cuts and the harness is properly clamped.

Results:

- OK – Proceed to Test Step 6.
- Not OK – Repair the wires or replace the wires, as required. If the fault has not been eliminated proceed to test step 6.

Test Step 6. Check Connectors for Moisture or Corrosion.

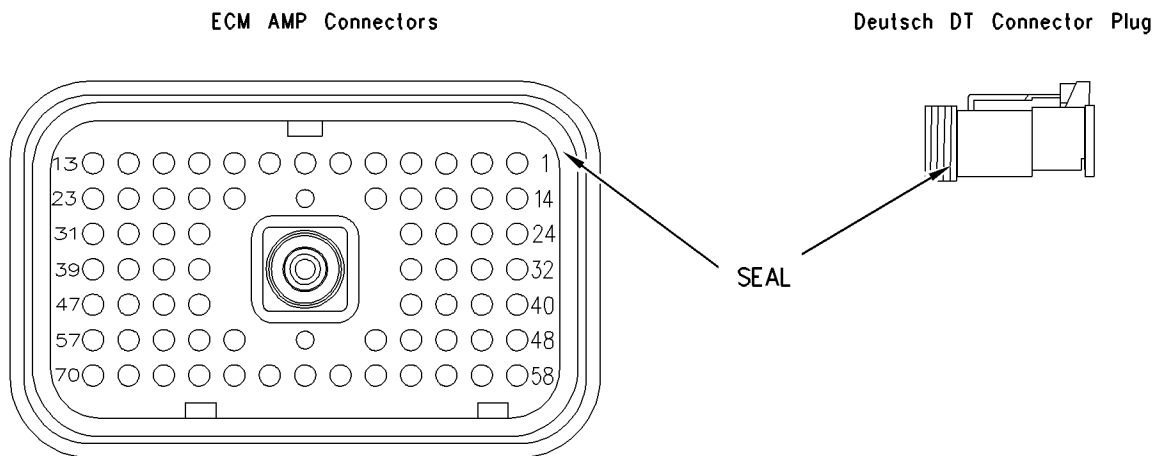

Illustration 62
Connector seals

g00705443

- A.** Ensure that the connector seals and the white sealing plugs are in place. If any of the seals or plugs are missing, replace the seal or plug. If necessary, replace the connector.
- B.** Check all of the wiring harnesses in order to verify that the harness does not make a sharp bend out of a connector. This will deform the connector seal and this will create a path for the entrance of moisture.

Thoroughly inspect ECM connectors J1/P1 and J20/P20 for evidence of moisture entry.

Note: It is normal to see some minor seal abrasion on the ECM connector seals. Minor seal abrasion will not allow the entry of moisture.

C. If moisture or corrosion is evident in the connector, the source of the moisture entry must be found and the source of the moisture entry must be repaired. If the source of the moisture entry is not repaired, the problem will reoccur. Simply drying the connector will not fix the problem. Likely paths for the entrance of moisture are in the following list:

- Missing seals
- Improperly installed seals
- Nicks in exposed insulation
- Improperly mated connectors

Moisture can also travel from one connector through the inside of a wire to the ECM connector. If moisture is found in the ECM connector, thoroughly check all connectors and wires on the harness that connect to the ECM. The ECM is not the source of the moisture. Do not replace an ECM if moisture is found in either ECM connector.

Note: If corrosion is evident on the pins, sockets, or the connectors, use only denatured alcohol to remove the corrosion. Use a cotton swab or a soft brush to remove the corrosion. Do not use any cleaners that contain trichloro-ethylene because trichloro-ethylene may damage the connector.

Expected Result:

All of the connectors should be completely coupled and all of the seals should be completely inserted. The harness and the wiring should be free of corrosion, abrasion or pinch points.

Results:

- OK – Proceed to Test Step 7.
- Not OK

Repair: Repair the connectors and/or wiring, or replace the connectors and/or wiring. Ensure that all of the seals are properly in place and ensure that the connectors are completely coupled.

Verify that the repair eliminates the problem by running the engine for several minutes and by checking again for moisture. If moisture reappears then the moisture may be contained within the insulation of the wiring. Replace any wires that may contain moisture inside the insulation. Verify that the repair eliminates the problem.

If the repair has not eliminated the fault proceed to test step 7.

Test Step 7. Inspect the Connector Terminals.

- A. Verify that the terminals are not damaged. Verify that the terminals are properly aligned in the connector and verify that the terminals are properly located in the connector.

Expected Result:

The terminals are properly aligned and the terminals appear undamaged.

Results:

- OK – Proceed to Test Step 8.
- Not OK – Repair the terminals and/or wiring, or replace the terminals and/or wiring. If the repair has not eliminated the fault proceed to test step 8.

Test Step 8. Check Individual Pin Retention into the Socket.

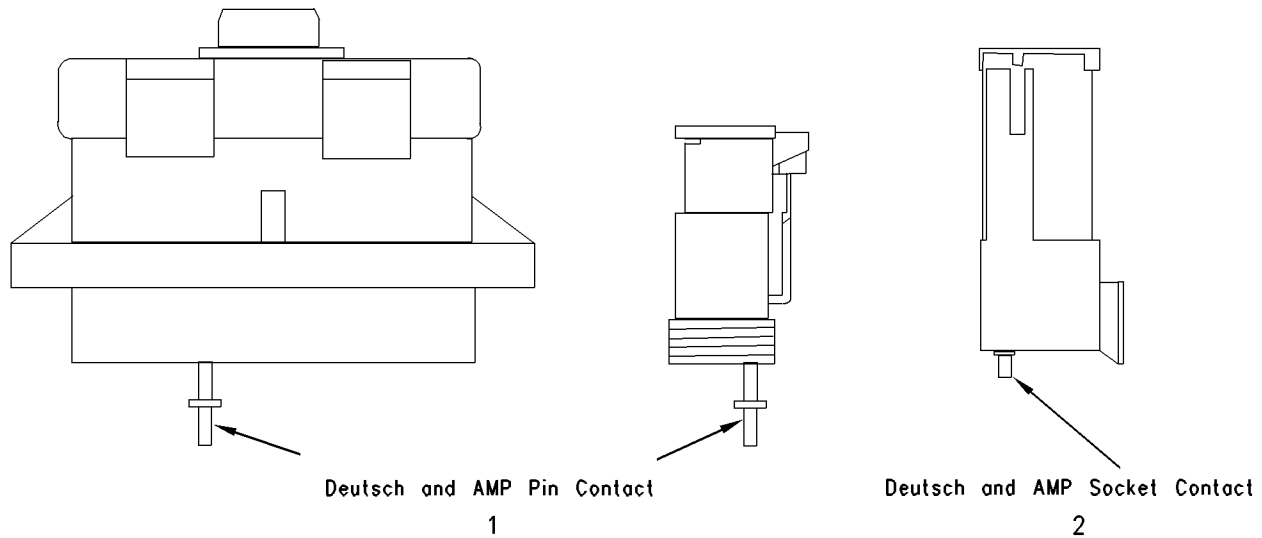

Illustration 63

g00640220

Pin retention of the connector

(1) Contact point

(2) Contact of the socket

Note: This is especially important for intermittent faults.

i01798200

- A.** Use a new pin. Insert the pin into each socket one at a time in order to check for a good grip on the pin by the socket.
- B.** Use a new socket. Insert the socket over each pin one at a time in order to check for a good grip on the pin by the socket. The pins are located on the mating side of the connector.
- C.** The contact terminal should stay connected when the connector is held in the position shown in Illustration 63. The contact terminal is the pin or the socket.

Expected Result:

The pins and the sockets appear to be OK.

Results:

- OK – STOP.
- Not OK – Replace the terminal. STOP.

Electrical Power Supply Circuit - Test

System Operation Description:

Use this procedure under the following conditions:

This procedure tests whether the correct voltage is supplied by the wiring. Use this procedure if the diagnostic code is logged or active.

- 253-02 Incorrect ECM Software

Note: This code can be generated by rapidly cycling the keyswitch. If this occurs, clear the logged diagnostic codes in order to prevent future confusion or an incorrect diagnosis.

The electronic service tool will indicate Low Battery Voltage if the ECM is not receiving the battery supply voltage.

Also use this procedure if another procedure has directed you here.

The following background information is related to this procedure:

The ECM receives electrical power (battery voltage) through the wiring within the engine harness. The ECM input at connector P1:70 (keyswitch) receives battery voltage from the keyswitch when the keyswitch is in the ON position or the START position. The ECM will power up when the ECM detects battery voltage at the keyswitch. The ECM will power down when battery voltage is removed from the keyswitch.

The cause of an intermittent power supply to the ECM can occur on either the positive side (unswitched +battery) or the negative side (battery negative). Both sides are routed from the ECM to the battery. The three connections for the unswitched +battery should be routed through a dedicated protection circuit.

The engine ECM requires the keyswitch to be in the ON position in order to maintain communications.

Temporarily bypassing the engine wiring may be an effective means of determining the root cause of intermittent problems such as intermittent shutdowns. If the symptoms disappear with the bypass wiring, the engine wiring is the cause of the problem. A means of bypassing engine wiring is explained in this test procedure.

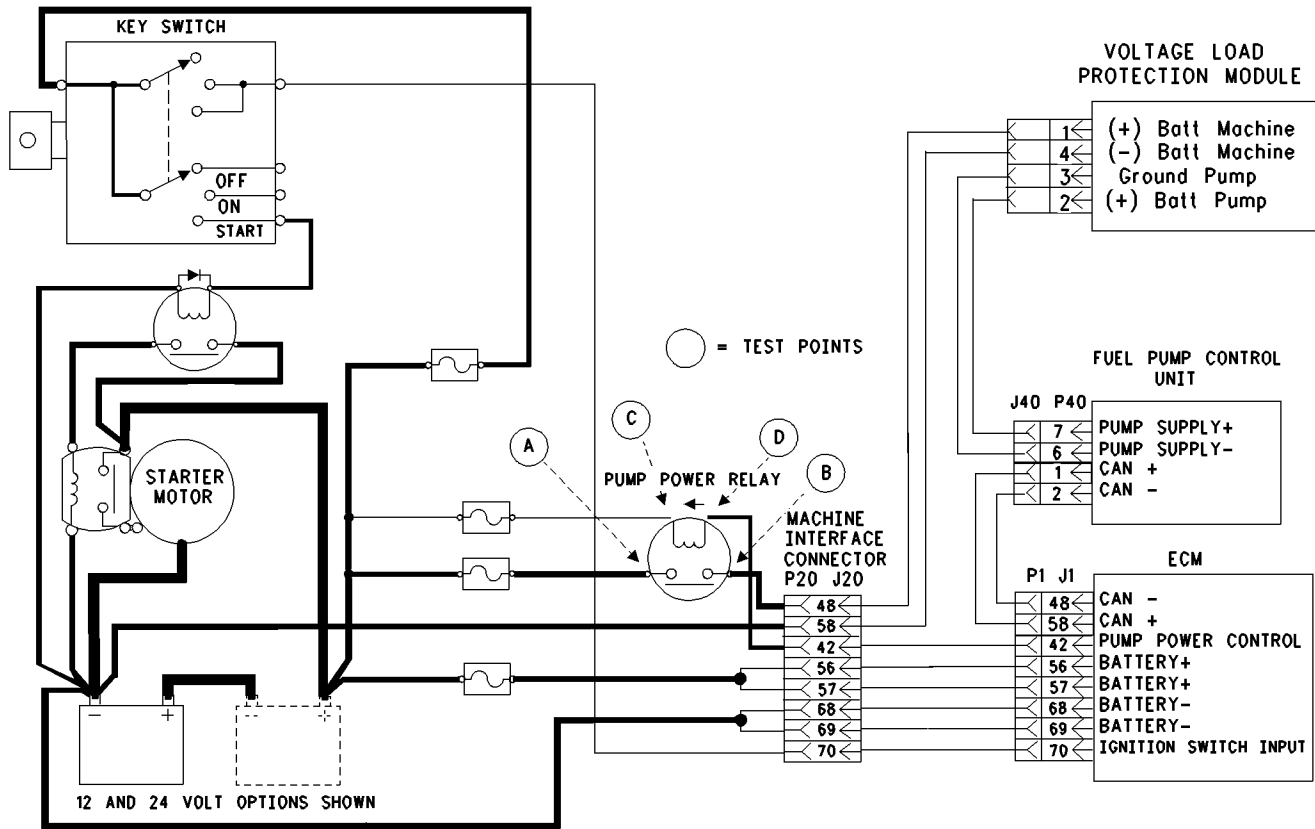

Illustration 64
Schematic of the power supply for the fuel injection pump

g00910876

⚠ WARNING

Batteries give off flammable fumes which can explode.

To avoid injury or death, do not strike a match, cause a spark, or smoke in the vicinity of a battery.

Test Step 1. Check The Batteries.

- Measure no-load battery voltage at the battery posts.
- Load test the batteries.

Note: The batteries must pass the load test. The minimum voltage must be 11.5 volts for a 12 volt battery. If the battery voltage of a 12 volt battery is below 12.4 volts then the battery needs to be charged.

Expected Result:

If the batteries are OK proceed to Test Step 2.

Results:

- Not OK – Recharge or replace the batteries. Verify that the repair eliminates the problem. STOP.

Test Step 2. Inspect Electrical Connectors And Wiring.

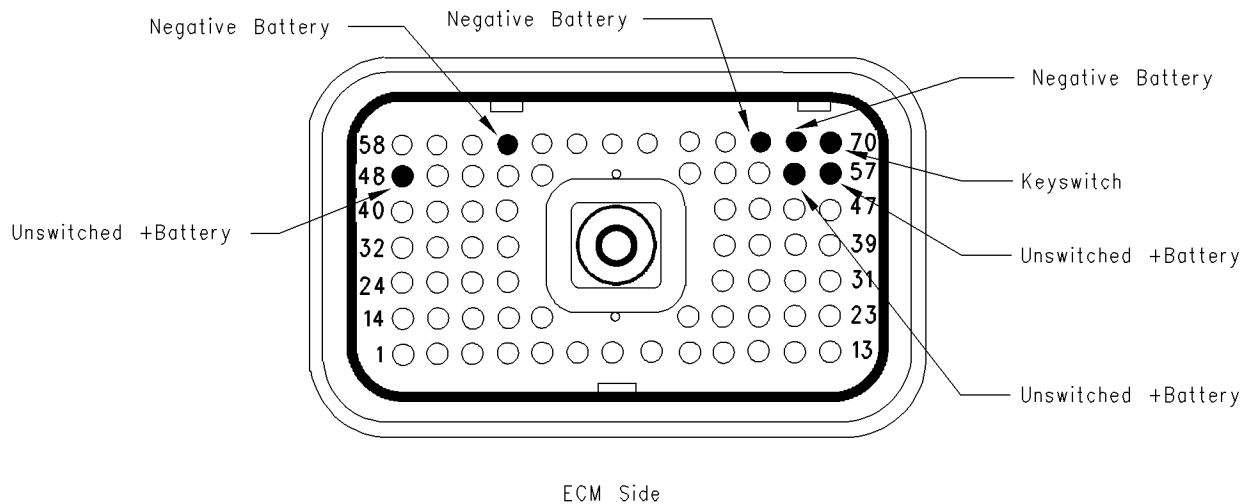

Illustration 65

g00905719

- A.** Thoroughly inspect the harness connector J1/P1. Also inspect the connections for the battery and the connections to the keyswitch. Refer to Troubleshooting, "Electrical Connectors - Inspect" for details.
- B.** Perform a 45 N (10 lb) pull test on each of the wires in the ECM connector that are associated with the following connections:
 - P1:48, P1:56, and P1:57 (Unswitched positive battery)
 - P1:61, P1:68, and P1:69 (Negative battery)
 - P1:70 (Keyswitch)
- C.** Check the ECM connector (Allen head screw) for the proper torque of 6.0 N·m (55 lb in).
- D.** Check the harness and wiring for abrasions and for pinch points from the battery to the ECM. Also, check the harness and wiring for abrasions and for pinch points from the keyswitch to the ECM.

Expected Result:

All connectors, pins, and sockets should be completely coupled and/or inserted. The harness and wiring should be free of corrosion, abrasion, and/or pinch points.

Results:

- OK – Proceed to Test Step 3.
- Not OK – There is a problem with the connectors or wiring.

Repair: Repair the connectors or wiring and/or replace the connectors or wiring. Ensure that all of the seals are properly in place and ensure that the connectors are completely coupled.

STOP.

Test Step 3. Check the Battery Voltage at the ECM.

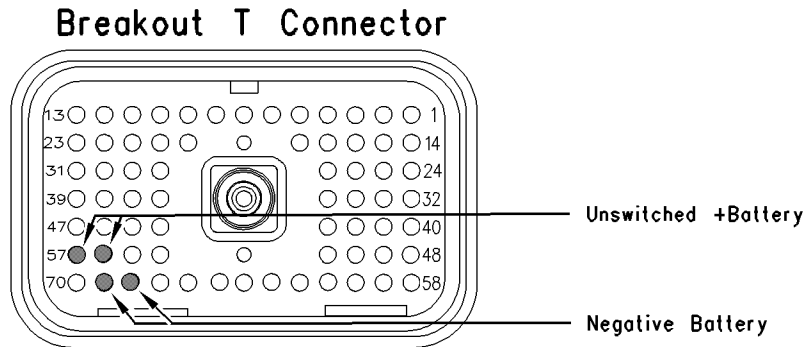

Illustration 66

g00955807

Test points for the Breakout T.

- A. Disconnect engine harness connector P1 from ECM connector J1 and insert a 70 Pin Breakout T.
- B. Reconnect the harness.
- C. Turn the keyswitch to the ON position.
- D. Measure the voltage between P1:56 (unswitched positive battery) and P1:68 (negative battery).
- E. Measure the voltage between P1:57 (unswitched positive battery) and P1:69 (negative battery).

Refer to Illustration 66 for the ECM Breakout T-connector.

Expected Result:

The measured voltage is between 11.0 VDC and 13.5 VDC for a 12 volt system and between 22.0 VDC and 27.0 VDC for a 24 volt system with no suspected intermittent problems at this time.

If the ECM is receiving the correct voltage, proceed to Test Step 4.

If the ECM is not receiving the correct voltage and an intermittent condition is suspected, refer to Troubleshooting, "Electrical Connectors - Inspect". Repair any damaged connectors or damaged wiring and/or replace any damaged connectors or damaged wiring. Verify that the repairs eliminate the problem and proceed to Test Step 4.

If the voltage at the keyswitch is out of the nominal range, trace the wiring for the keyswitch from the ECM through the keyswitch circuit to the batteries. Identify the problem and repair the problem. Check the circuit protection for the circuit and for the wiring.

Verify that the repairs eliminate the problem.

Results:

- OK – Proceed to Test Step 4.

Test Step 4. Use the Bypass Harness for the Electronic Service Tool to Bypass the Machine Wiring.

WARNING

Batteries give off flammable fumes which can explode.

To avoid injury or death, do not strike a match, cause a spark, or smoke in the vicinity of a battery.

NOTICE

Do Not connect the bypass harness to the battery until the 20 Amp in-line fuse has been removed from the +battery line. If the fuse is not removed before connection to the battery, a spark may result.

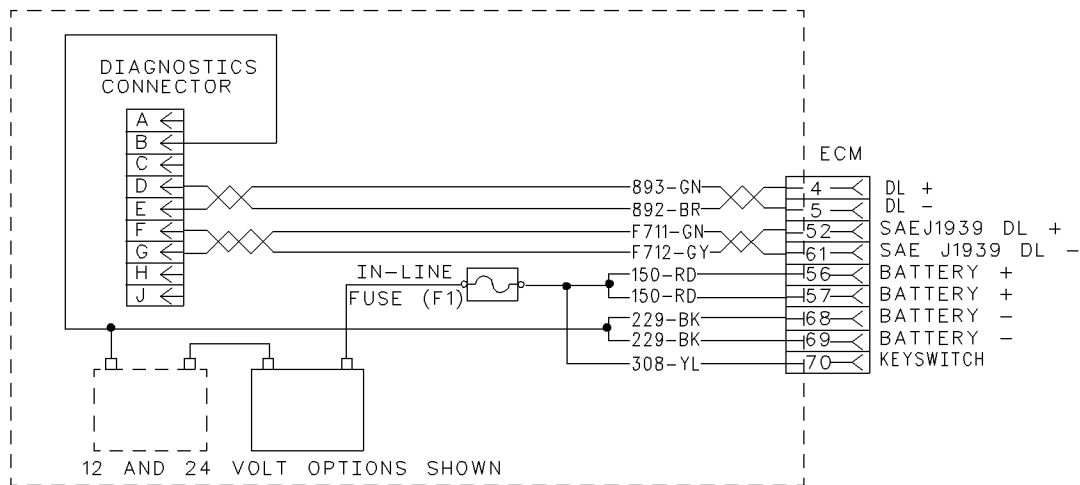

Illustration 67

g00954776

Bypass harness

Note: This bypass harness is only for test applications. This bypass harness may be left only temporarily on the engine. The bypass harness can be used in order to determine if the cause of the intermittent problem is the interruption of the power supply from the battery to the ECM or to the keyswitch circuit.

- A. Turn the keyswitch to the OFF position.
- B. Disconnect harness connector J1/P1 from the ECM.
- C. Remove the 20 Amp in-line fuse from the bypass harness and connect the harness to the ECM connector J1.

Note: This bypass directly connects the circuit for the keyswitch to the ECM. The ECM will remain powered until the connection to the unswitched battery line "+" is disconnected from the battery post. The removal of the 20 Amp fuse will ensure that the ECM will remain without power while connections are being made. The 20 Amp fuse should also be removed before disconnecting the battery connections.

- D. Connect an electronic service tool to the Data Link connector. Connect the unswitched + battery and the negative wire of the battery directly to the battery posts in order to ensure the correct polarity.

- E. Replace the 20 Amp in-line fuse. Verify that communication from the service tool is established. Perform any necessary diagnostic tests.
- F. Remove the 20 Amp in-line fuse. Disconnect the bypass harness. Restore all wiring to the original condition. Replace the fuse in the disconnected bypass harness.

Expected Result:

Installing the bypass eliminates the problem.

Results:

- OK – The symptoms disappear when the bypass harness is installed. Also, the symptoms return when the bypass harness is removed. The problem is in the wiring that supplies power to the ECM. Repair the wiring that supplies power to the ECM. STOP.
- Not OK

Repair: If the problem still exists, temporarily connect a test ECM. Remove all jumpers and replace all connectors. The test ECM must be programmed with the same parameters as the suspect ECM. Recheck the system for active diagnostic codes and repeat the Test Step. If the problem is resolved with the test ECM, reconnect the suspect ECM. If the problem returns with the suspect ECM, replace the suspect ECM.

Verify that the repair eliminates the problem.

STOP.

i01798870

Engine Oil Level Switch Circuit - Test

System Operation Description:

The Low Oil Level Switch signals the Electronic Control Module (ECM) if the oil level falls below a predetermined level in the oil pan. The ECM warns the operator of possible engine damage. The switch uses a float that closes the circuit when the oil level is above a predetermined level.

The ECM may modify the operation of the engine in the event of low oil level. The ECM cannot determine if the oil level switch or associated components have failed.

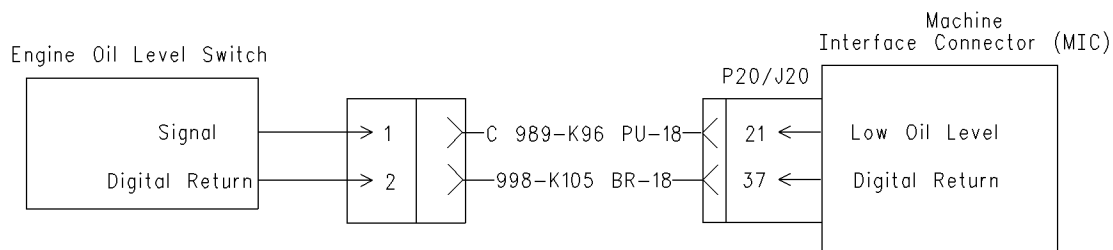

Test Step 1. Check for Connector Damage.

- A. Turn the circuit breaker for the battery to the OFF position.
- B. Turn the keyswitch to the OFF position.
- C. Disconnect the main power.
- D. Thoroughly inspect the ECM connectors J1/P1 and J20/P20. Inspect all of the other connectors. Refer to the diagnostic functional test Troubleshooting, "Inspecting Electrical Connectors" for details.
- E. Perform a 45 N (10 lb) pull test on each of the wires in the ECM connector that are associated with the circuit.
- F. Check the ECM connector (Allen head screw) for the proper torque of 6.0 N·m (55 lb in).
- G. Check the customer connector (Allen head screw) for the proper torque of 2.25 ± 0.25 N·m (20 ± 2 lb in).
- H. Check the harness and the wiring for abrasion and pinch points.

Expected Result:

The connectors and wiring should be free of the following problems: damage, corrosion, abrasion, and incorrect attachment.

Results:

- OK – The connectors and the wiring are okay. Proceed to test step 2.
- Not OK – The connectors and/or wiring are not okay.

Repair: Repair the connectors or wiring and/or replace the connectors or wiring.

STOP.

Test Step 2. Check the Engine Oil Level

- A. Check the engine oil level.
- B. Ensure that the correct engine oil dipstick is installed.
- C. Check for external oil leaks.

Expected Result:

The engine oil should be at the correct level.

Results:

- OK – The engine oil level is correct. Proceed to test step 3.
- Not OK – The engine oil level is not correct.

Repair: If necessary, add oil to the engine.

STOP.

Test Step 3. Use the Electronic Service Tool in order to Check the Engine Oil level.

- A. Connect the electronic service tool to the service tool connector.
- B. Turn the keyswitch to the ON position. The engine should be off.
- C. Observe the "Engine Oil Level" reading on the electronic service tool.

Expected Result:

The "Engine Oil Level" should read "OK".

Results:

- OK – The "Engine Oil Level" does read "OK".

Repair: The switch signal is correct.

STOP.

- Not OK – The "Engine Oil Level" does not read "OK". The switch signal is not correct. Proceed to test step 4.

Test Step 4. Short the Wires at the Low Oil Level Switch.

- A. Disconnect the low oil level switch.
- B. Use a wire to short the wires for the "engine oil level switch".
- C. Turn the keyswitch to the ON position. The engine should be off.
- D. Observe the status of the "Engine Oil Level" on the electronic service tool.
- E. Remove the wire short.
- F. Observe the status of the "Engine Oil Level" on the electronic service tool.
- G. Turn the keyswitch to the OFF position.

Expected Result:

The electronic service tool should indicate “OK” when the wire short is installed. The electronic service tool should indicate “LOW” when the wire short is removed.

Results:

- OK – The electronic service tool screen indicates “OK”, when the wire short is in place. The electronic service tool screen indicates “LOW”, when the wire short is removed. The electronic service tool recognized the input from the switch.

Repair: Temporarily replace the switch. Verify that the new switch solves the problem before you permanently install the new switch.

STOP.

- Not OK – The electronic service tool screen does not indicate “OK”, when the wire short is in place. The electronic service tool screen does not indicate “LOW”, when the wire short is removed. The electronic service tool screen does not recognize the switch input from the switch. Proceed to test step 5.

Test Step 5. Check For Shorts in the Wiring Harness.

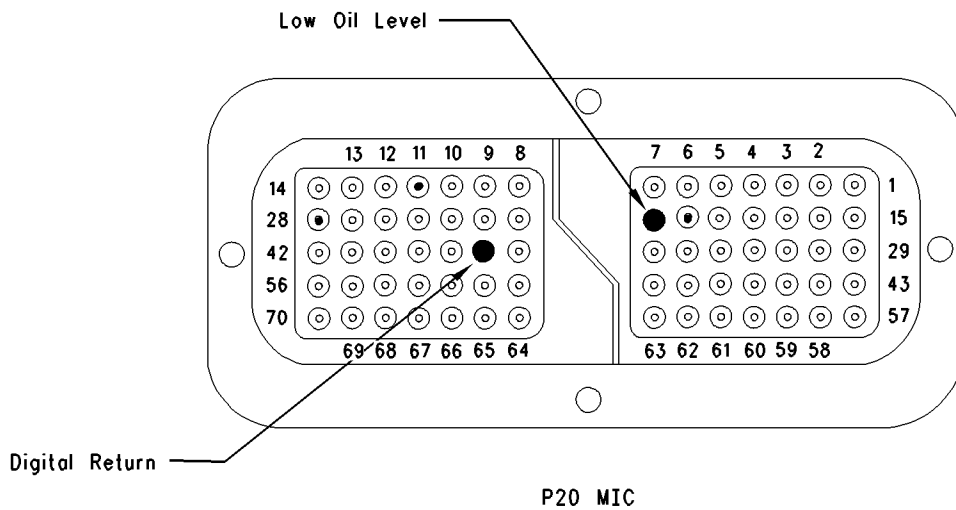

- A. Disconnect ECM connector J20/P20.
- B. Measure the resistance between P20:21 and P20:37.
- C. Measure the resistance between P20:21 and the engine ground.
- D. Measure the resistance between P20:37 and the engine ground.

Expected Result:

The resistance should be greater than 20,000 ohms.

Results:

- OK – The resistance is greater than 20,000 ohms. Proceed to test step 6.
- Not OK – The resistance is less than 20,000 ohms. There is a short in the wiring harness.

Repair: Repair the connectors or wiring and/or replace the connectors or wiring.

STOP.

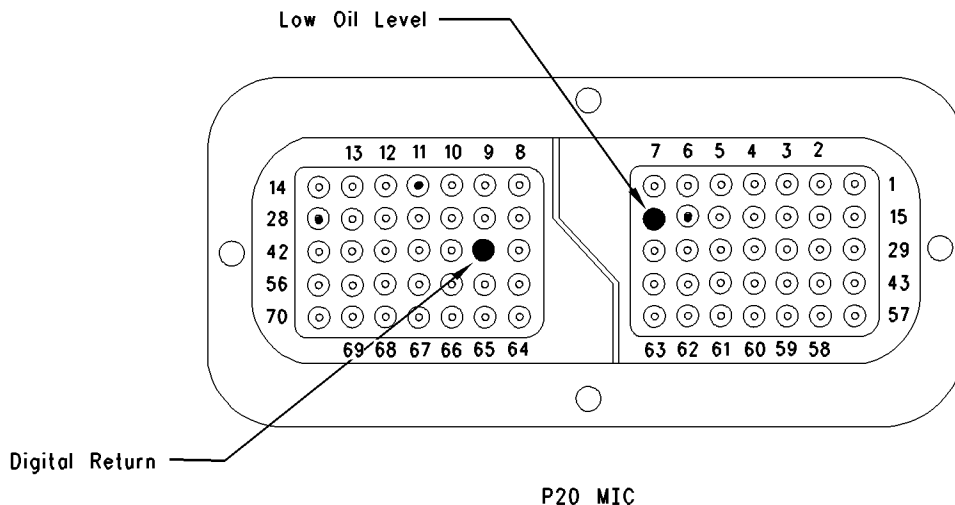
Test Step 6. Check the Resistance through the Harness.

- A. Measure the resistance between P20:21 and P20:37 at the MIC.

Expected Result:

The resistance should be less than 10 ohms.

Results:

- OK – The resistance is less than 10 ohms.
Proceed to test step 7.
- Not OK – The resistance is greater than 10 ohms.
There is an open circuit or excessive resistance in the wiring harness.

Repair: Repair the connectors or wiring and/or replace the connectors or wiring.

STOP.

Test Step 7. Short the Input Wires of the Oil Level Switch at the MIC Machine Interface Connector

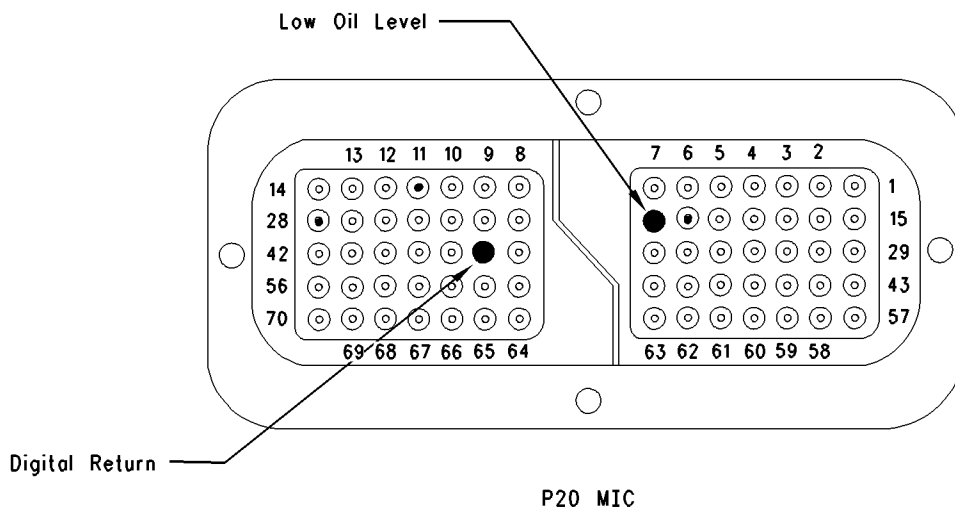

Illustration 71

g00955140

- Remove the wires P20:21 and P20:37 from the Machine Interface Connector (MIC).
- Insert a jumper wire between P20:21 and P20:37 at the MIC.
- Reconnect all connectors.
- Turn the keyswitch to the ON position. The engine should be OFF.

Note: Additional diagnostic codes will be generated because the digital return will no longer be connected to the other sensors and switches. Ignore the codes and clear the codes when you complete this test.

- Observe the status of the "Engine Oil Level" on the electronic service tool.
- Turn the keyswitch to the OFF position.
- Disconnect J20/P20 MIC and remove the wire short.
- Reconnect all connectors.

- I. Turn the keyswitch to the ON position. The engine should be OFF.
- J. Observe the status of the “Engine Oil Level” on the electronic service tool.

Expected Result:

The electronic service tool should indicate “OK” when the wire short is installed. The electronic service tool should indicate “LOW” when the wire short is removed.

Results:

- OK – The electronic service tool screen indicates “OK”, when the wire short is installed. The electronic service tool screen indicates “LOW”, when the wire short is removed. The harness is faulty.

Repair: Repair the connectors or wiring and/or replace the connectors or wiring.

STOP.

- Not OK – The electronic service tool screen does not indicate “OK”, when the wire short is in place. The electronic service tool screen does not indicate “LOW”, when the wire short is removed. The ECM is not reading the switch position.

Repair: Replace the ECM. Refer to the diagnostic procedure Troubleshooting, “Replacing the ECM”.

STOP.

i01798871

Engine Pressure Sensor Open or Short Circuit - Test

System Operation Description:

Use this procedure under the following conditions:

Use this procedure if another procedure has directed you here. Also use this procedure when there is an active fault for any of the following sensors:

- Oil pressure sensor
- The sensor for the Intake Manifold Pressure

The following background information is related to this procedure:

The troubleshooting procedures for the diagnostic codes of each pressure sensor are identical. The pressure sensors are sensors that have three terminals. The pressure sensors are active sensors. Active sensors require supply voltage from the Electronic Control Module (ECM). The ECM connector J1/P1 terminal 26 supplies +5 volts to terminal “A” of each sensor. The ECM connector J1/P1 terminal 34 is the common connection for the pressure sensors. The sensor common connection is shared between all of the pressure sensors. The common line is connected to each sensor connector terminal “B”. The signal voltage from terminal “C” of each sensor is supplied to the appropriate terminal at the ECM connector J1/P1.

Use this procedure for the following diagnostic codes:

- 100-03 Engine Oil Pressure Sensor Open Circuit or Shorted High
- 100-04 Engine Oil Pressure Sensor Shorted Low
- 100-10 Engine Oil Pressure Sensor Power Supply Open Circuit
- 102-03 Intake Manifold Pressure Sensor Open Circuit or Shorted High
- 102-04 Intake Manifold Pressure Sensor Shorted Low
- 102-10 Intake Manifold Pressure Sensor Power Supply Open Circuit

Note: The following diagnostic codes should not be active:

- 262-03 5 Volt Sensor Supply, voltage more than normal
- 262-04 5 Volt Sensor Supply, voltage less than normal

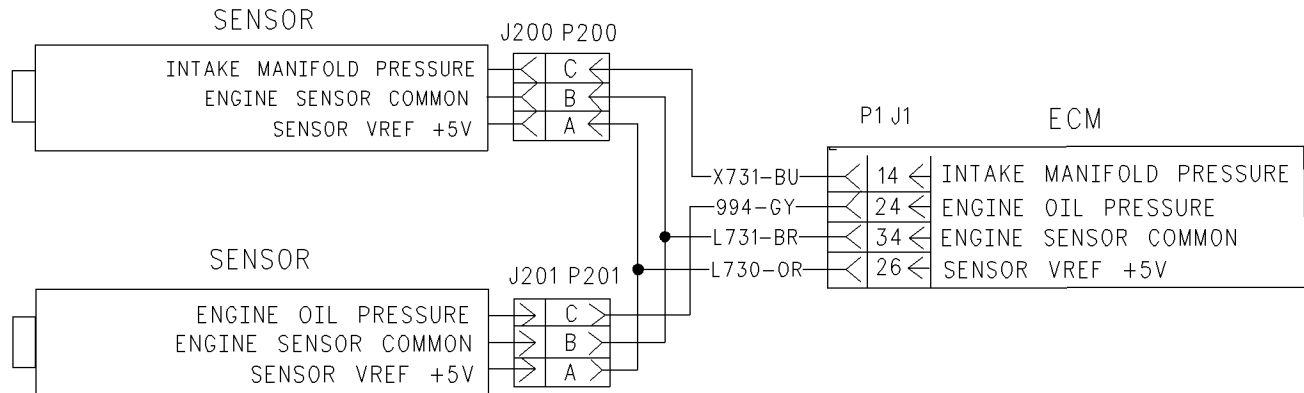

Illustration 72

g00954290

Schematic of pressure sensors

Test Step 1. Check For Active +5 V Sensor Supply Diagnostic Codes.

- A. Connect the electronic service tool to the diagnostic connector.
- B. Turn the keyswitch to the ON position. Wait at least 15 seconds for activation of the diagnostic codes.
- C. Verify if any of the following diagnostic codes are active:
 - 262-03 5 Volt Sensor Supply, voltage more than normal
 - 262-04 5 Volt Sensor Supply, voltage less than normal

Expected Result:

One or more of the preceding diagnostic codes are active.

Results:

- Yes

Repair: Perform the following diagnostic procedure: Troubleshooting, "5 Volt Engine Pressure Sensor Supply Circuit - Test".

STOP.

- No – Proceed to Test Step 2.

Test Step 2. Verify All Active Diagnostic Codes.

- A. Turn the keyswitch to the ON position. Wait at least 15 seconds for activation of the diagnostic codes.
- B. Verify if any of the following diagnostic codes are active:
 - 100-03 Engine Oil Pressure Sensor Open Circuit or Shorted High
 - 100-04 Engine Oil Pressure Sensor Shorted Low
 - 100-10 Engine Oil Pressure Sensor Power Supply Open Circuit
 - 102-3 Intake Manifold Pressure Sensor Open Circuit or Shorted High
 - 102-4 Intake Manifold Pressure Sensor Shorted Low
 - 102-10 Intake Manifold Pressure Sensor Power Supply Open Circuit

Note: The following diagnostic codes should not be active:

- 262-03 5 Volt Sensor Supply, voltage more than normal
- 262-04 5 Volt Sensor Supply, voltage less than normal

Expected Result:

One or more of the preceding diagnostic codes are active.

Results:

- Yes – Proceed to Test Step 3.
- No

Repair: If the preceding codes are logged but not active and the engine is not running properly, refer to Troubleshooting, “Troubleshooting without a Diagnostic Code”. If the engine is running properly at this time, an intermittent condition may be causing the logged codes. Refer to Troubleshooting, “Electrical Connectors - Inspect”.

STOP.

Test Step 3. Inspect Electrical Connectors And Wiring.

Illustration 73

g00955141

A. Thoroughly inspect the following terminal connections on the P1 ECM connector:

- P:14 Intake Manifold Pressure
- P:24 Engine Oil Pressure
- P:26 +5 V
- P:34 Sensor Common

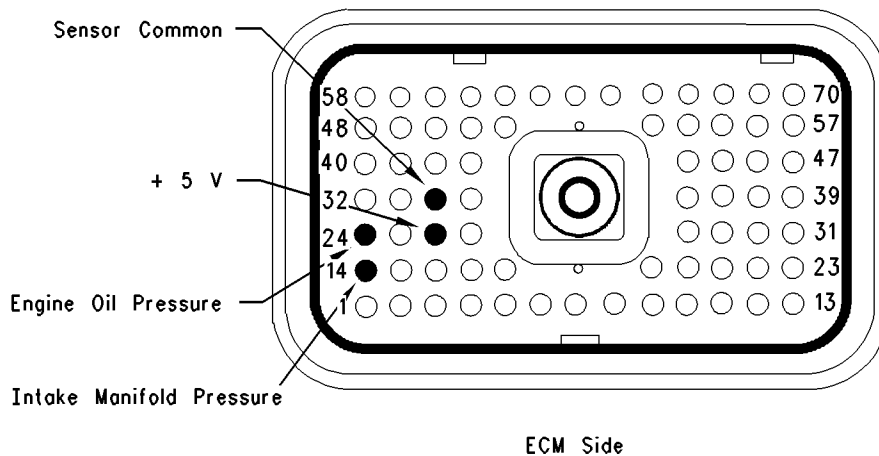
B. Thoroughly inspect the following engine pressure sensors:

- J1/P1 ECM Engine Harness Connector
- J20/P20 Machine Interface Connector
- J200/P200 Intake Manifold Pressure Sensor
- J201/P201 Engine Oil Pressure Sensor

- C. Refer to Troubleshooting, “Electrical Connectors - Inspect”.
- D. Perform a 45 N (10 lb) pull test on each of the wires in the ECM connector and the sensor connectors that are associated with the active diagnostic code.

Refer to Illustration 73.
- E. Check the ECM connector (Allen head screw) for the proper torque of 6.0 N·m (55 lb in).
- F. Check the harness and wiring for abrasions and for pinch points from the sensors back to the ECM.

Expected Result:

All connectors, pins, and sockets should be completely coupled and inserted. The harness and wiring should be free of corrosion, abrasion, and pinch points.

Results:

- OK – Proceed to Test Step 4.
- Not OK

Repair: Repair the connectors or wiring and/or replace the connectors or wiring. Ensure that all of the seals are properly in place and ensure that the connectors are completely coupled.

Verify that the repair eliminates the problem.

Use the electronic service tool in order to clear all logged diagnostic codes.

STOP.

Test Step 4. Verify that the Diagnostic Code is Still Active.

- A. Turn the keyswitch to the ON position. Wait at least 15 seconds for activation of the diagnostic codes.
- B. Use the electronic service tool to check for active diagnostic codes. Record all active diagnostic codes.
- C. Determine if the problem is related to an open circuit diagnostic code or a short circuit diagnostic code.

Expected Result:

Either a short circuit diagnostic code is active or an open circuit diagnostic code is active.

Results:

- SHORT Circuit – A short circuit diagnostic code is active at this time. Proceed to Test Step 5.
- OPEN Circuit – An open circuit diagnostic code is active at this time. Proceed to Test Step 6.

Test Step 5. Disconnect The Sensor In Order To Create An Open Circuit.

- A. Turn the keyswitch to the OFF position.
- B. Disconnect the sensor connector of the sensor with the short circuit diagnostic code.
- C. Turn the keyswitch to the ON position. Wait at least 15 seconds for activation of the diagnostic codes.
- D. Use the electronic service tool to check the “Active Diagnostic Code” screen. Check for an open circuit diagnostic code.

Expected Result:

An open circuit diagnostic code for the disconnected sensor is now active.

Results:

- OK – A short circuit diagnostic code was active before disconnecting the sensor. An open circuit diagnostic code became active after disconnecting the sensor. Proceed to Test Step 7.
- Not OK – There is a short circuit between the sensor harness connector and the ECM. Leave the sensor disconnected. Proceed to Test Step 9.

Test Step 6. Measure the Sensor Supply Voltage.

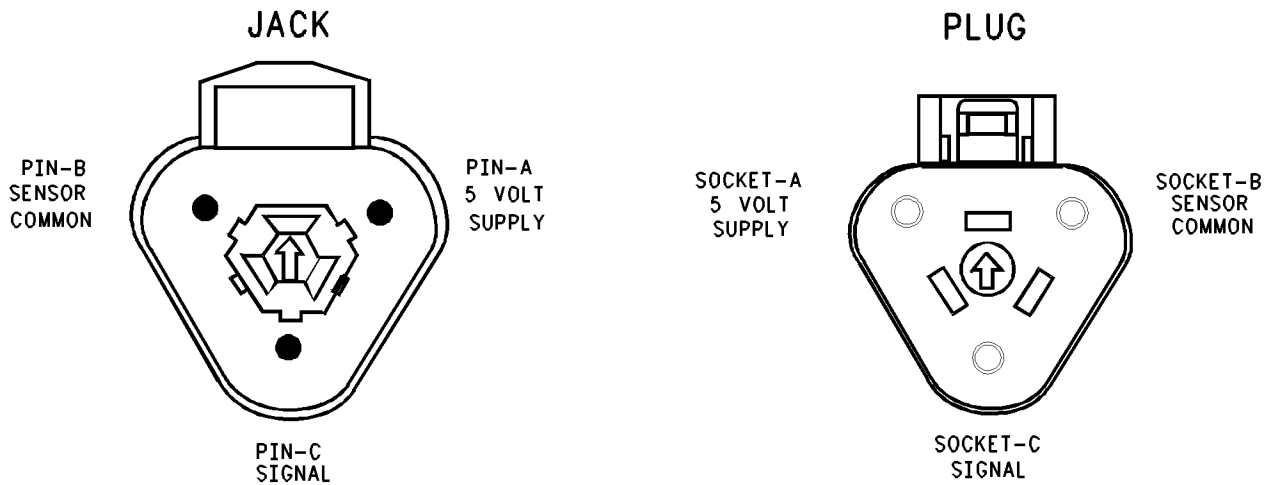

Illustration 74

g00664397

- A. Turn the keyswitch to the OFF position.
- B. Disconnect the sensor from the engine harness.
- C. Connect a 3-Terminal Breakout T to the engine harness only. Do not connect the sensor to the Breakout T.
- D. Turn the keyswitch to the ON position.
- E. Measure the voltage from the terminal "A" (pressure sensor supply) to terminal "B" (sensor common).

Expected Result:

The DC voltage from terminal "A" to terminal "B" measures 4.5 to 5.5 VDC.

Results:

- OK – The sensor supply voltage is correct. Remove the Breakout T. Proceed to Test Step 8.
- Not OK – The sensor supply voltage is out of the nominal range. Continue testing the sensor supply circuit.

Repair: Proceed to the following repair: Troubleshooting, "5 Volt Engine Pressure Sensor Supply Circuit - Test"

STOP.

Test Step 7. Determine If The Short Circuit Is In The Connector Or In The Sensor.

- A. Thoroughly inspect the connector for moisture.
- B. Inspect the seals and reconnect the sensor.
- C. Refer to Troubleshooting, "Electrical Connectors - Inspect".
- D. If the short circuit diagnostic code reappears, the sensor or the pigtail harness connector is the problem.
 - a. Temporarily connect a new sensor to the harness, but do not install the new sensor in the engine.
- E. Use the electronic service tool to verify that there is a short circuit diagnostic code. The new sensor should be connected to the harness at this time.

Expected Result:

The short circuit diagnostic code is not present when a new sensor is connected.

Results:

- OK – Verify that the repair eliminates the problem. Use the electronic service tool to clear the logged diagnostic codes. STOP.
- Not OK – Repair the engine harness connector. STOP.

Test Step 8. Create a Short Circuit Between the Signal and the Common Terminals at the Engine Harness Connector.

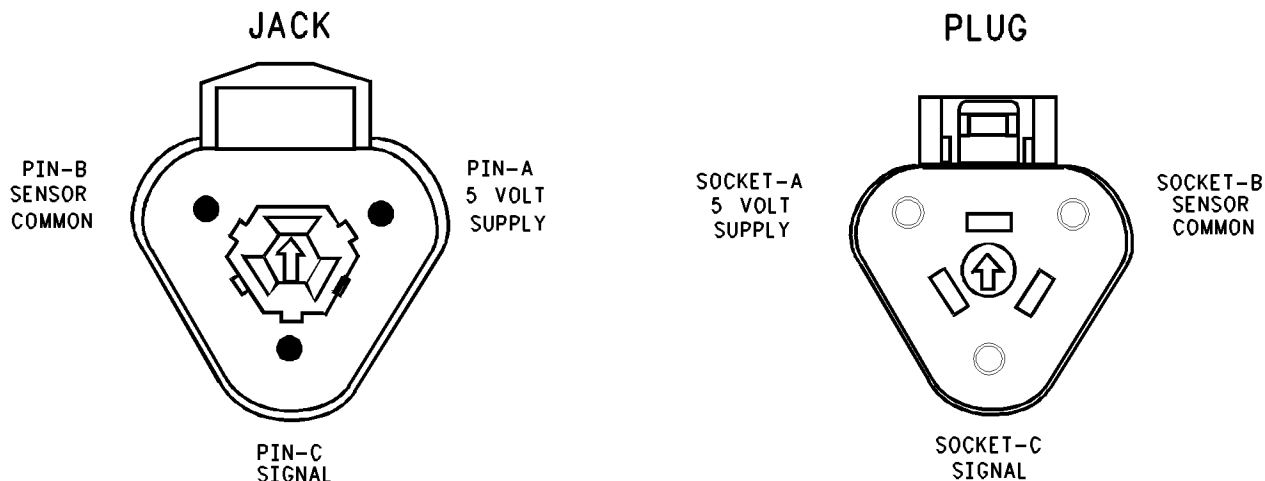

Illustration 75

g00664397

Terminals for the pressure sensor connector

- A. Turn the keyswitch to the ON position.
 - B. Fabricate a jumper wire 150 mm (6 inch) long. Crimp a Deutsch terminal to both ends of the wire.
 - C. Monitor the “Active Diagnostic Code” screen of the electronic service tool before installing the jumper wire and after installing the jumper wire.
 - D. Install the jumper on the engine harness connector. Install one end of the jumper at the sensor signal (terminal “C”). Install the other end of the jumper at the common connection for the pressure sensor (terminal “B”). Wait at least 15 seconds for activation of the short circuit diagnostic code.
- Refer to Illustration 75.
2. Use the electronic service tool to verify if the diagnostic code remains active.
 3. If the diagnostic code is active replace the sensor.
 4. Use the electronic service tool to verify that the repair eliminated the problem.
- STOP.
- Not OK – The open circuit diagnostic code remains active when the jumper is installed. The most probable location for the open circuit is in the common wire for the sensor, or in the sensor signal wire of the engine harness between the ECM and the sensor. Remove the jumper. Proceed to test step 9.

Expected Result:

A short circuit diagnostic code is active when the jumper is installed. An open circuit diagnostic code is active when the jumper is removed.

Results:

- OK – The engine harness and the ECM are OK.

Repair: Perform the following repair:

1. Temporarily connect the suspect sensor.

Test Step 9. Check the Operation of the ECM by Creating Open and Short Circuits at the ECM Connector.

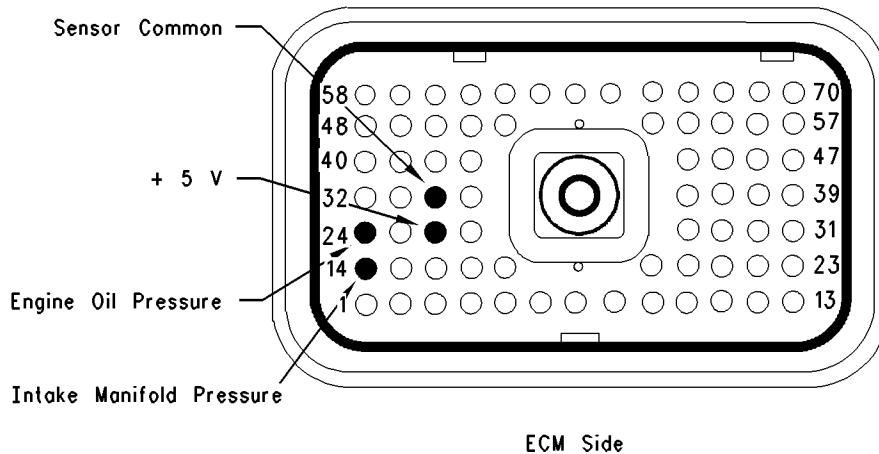

Illustration 76

g00955141

- A.** Turn the keyswitch to the OFF position.
- B.** Disconnect J1/P1.ECM connector. Thoroughly inspect both halves of the connectors for signs of corrosion or moisture.
- C.** Refer to Troubleshooting, “Electrical Connectors - Inspect”.
- D.** Reconnect J1/P1 ECM connector.
- E.** Turn the keyswitch to the ON position. Monitor the “Active Diagnostic Code” screen of the electronic service tool. Wait at least 15 seconds for activation of the code.
- An open circuit diagnostic code should be active for the suspect sensor.
- Note:** When the engine harness is disconnected, all of the open circuit diagnostic codes for the pressure sensors will be active. This is normal. Disregard the diagnostic codes for the other pressure sensors. Direct your attention to the diagnostic codes for the suspect sensor only.
- F.** Turn the keyswitch to the OFF position.
- G.** Fabricate a jumper wire 150 mm (6 inch) long. Crimp a Deutsch socket to both ends of the wire.

- H.** Install the jumper wire on the ECM connector J1. Insert the jumper wire between the terminal for the suspect sensor signal and the common connection for the engine’s pressure sensor (terminal 3).

Use the electronic service tool to verify that there is a short circuit diagnostic code.

Refer to Illustration 76 for the ECM connectors.

Expected Result:

Open circuit diagnostic codes and short circuit diagnostic codes were active.

Results:

- OK – The ECM is operating properly. Proceed to Test Step 10.
- Not OK – One of the following conditions exists: The open circuit diagnostic code is not active when the harness is disconnected. The short circuit diagnostic code is not active when the jumper wire is installed.

Repair: Perform the following repair:

1. Temporarily connect a test ECM.

Note: The test ECM should have the same values and the same parameters as the suspect ECM.

2. Remove all jumpers and replace all connectors.
3. Use the electronic service tool to recheck the system for active diagnostic codes.
4. Repeat the test step.
5. If the problem is resolved with the test ECM, reconnect the suspect ECM.
6. If the problem returns with the suspect ECM, replace the ECM.
7. Verify that the repair eliminates the problem.

STOP.

Test Step 10. Bypass the Harness Wiring Between the ECM and the Sensor Connector.

- A. Turn the keyswitch to the OFF position.
 - B. Disconnect J1/P1 ECM connector and the sensor connector.
 - C. Remove the sensor signal wire from the ECM connector.
 - D. Remove the signal wire (terminal "C") from the sensor connector on the engine harness.
 - E. Fabricate a jumper wire that is long enough to reach from the ECM to the sensor connector or use an engine sensor harness bypass with 3 terminals.
- Note:** If an engine sensor harness bypass is being made, crimp a Deutsch socket on one end in order to connect to the ECM. Crimp either a Deutsch pin or a Deutsch socket on the other end, as required.
- F. Insert the one end of the engine sensor harness bypass into P1 ECM connector on the engine harness. Insert the other end of the engine sensor harness bypass into the sensor connector of the engine harness.
 - G. Reconnect J1/P1 ECM engine connector and the sensor connector.
 - H. Turn the keyswitch to the ON position.
 - I. Use the electronic service tool to monitor the "Active Diagnostic Code" screen for either the open circuit diagnostic code for the sensor or the short circuit diagnostic code for the sensor.

Expected Result:

The diagnostic code disappears when the jumper or the bypass is installed.

Results:

- OK – There is a problem in the wiring harness.

Repair: Perform the following repair:

1. Repair the faulty wiring harness or replace the faulty wiring harness.
2. Clear all diagnostic codes.
3. Use the electronic service tool in order to verify that the repair eliminates the problem.

STOP.

- Not OK – Restart this procedure and carefully perform each step. STOP.

i01798872

Engine Speed/Timing Sensor Circuit - Test

System Operation Description:

Use this procedure to troubleshoot the system under the following conditions:

- There is an active diagnostic code for the engine speed/timing sensors.
- Use this procedure if another procedure has directed you here.

The engine uses two engine speed/timing sensors. One sensor is located in the cylinder block. The speed/timing sensor that is mounted on the cylinder block measures the crankshaft speed and the speed/timing sensor calculates the position of the crankshaft. In order to determine the engine rpm, the Electronic Control Module (ECM) measures the time between pulses that are created by the sensor as the speed-timing wheel rotates.

The second speed/timing sensor is located in the fuel injection pump. This speed/timing sensor measures the speed and the position of the fuel injection pump.

The ECM uses both sensor signals to calculate the engine speed and the correct engine timing.

The engine will start and the engine will run when only one sensor signal is present from either of the sensors. The loss of the signal from both of the sensors during engine operation will result in the termination of injection and the shutting down of the engine by the ECM. The loss of the signal from both of the sensors during start-up will prevent the engine from starting.

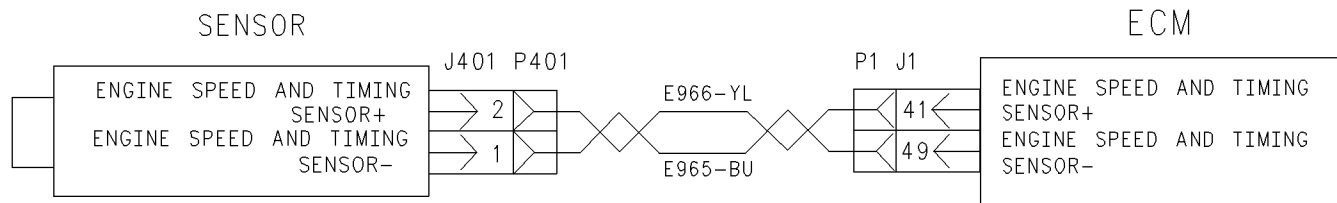

Illustration 77

g00835107

The schematic for the speed/timing sensor

Test Step 1. Inspect the Electrical Connectors and Cables

- A. Turn the keyswitch to the OFF position.
- B. Inspect the electrical connectors for damage.
Refer to Troubleshooting, "Electrical Connectors - Inspect".

Expected Result:

The electrical system is free from damage and faults.

Results:

- OK – There is no damage or faults. Proceed to Test Step 2.
- Not OK – There is damage to the electrical system components.

Repair: Repair the cables and/or the connectors or replace the cables and/or the connectors.

Ensure that all seals are in place and ensure that the connectors are correctly installed.

Verify that the repair has eliminated the fault.

STOP.

- Fault not eliminated – Proceed to Test Step 2.

Test Step 2. Check the Installation of the Engine Speed/Timing Sensors

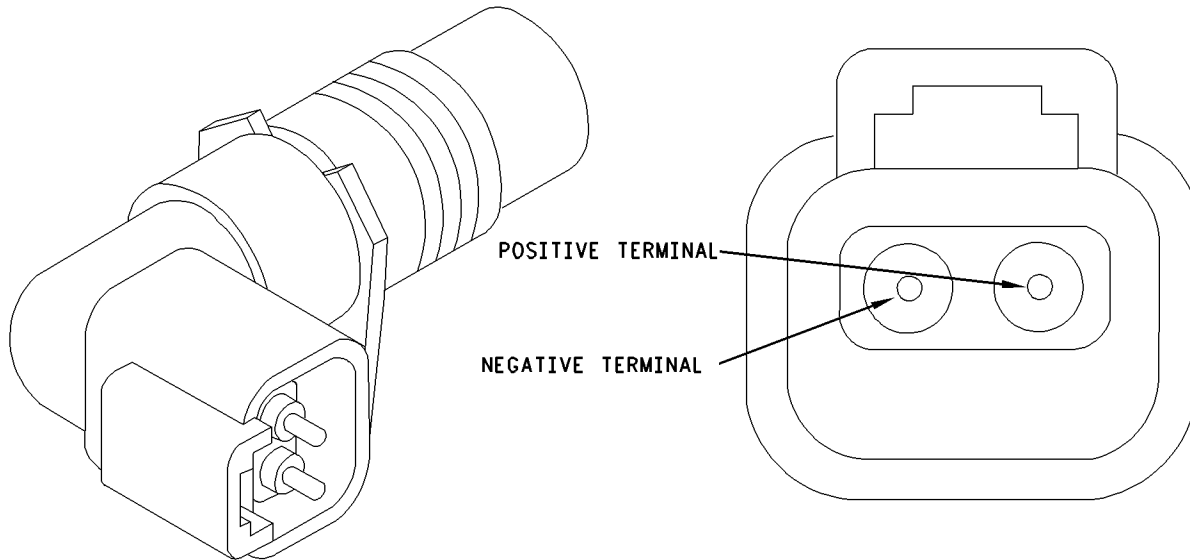

Illustration 78
Speed/timing sensor

g00985468

- A. Turn the keyswitch to the OFF position.
- B. Refer to troubleshooting, “Electrical Connectors - Inspect”.
- C. For correct operation, ensure that the metal plate of the engine speed/timing sensor is installed flat against the cylinder block.
- D. Check that the O rings have been installed properly on the sensor and that the O rings are not damaged.

Expected Result:

Check that the electrical connectors and the cables are properly installed.

Results:

- OK – The electrical connectors and the cables are properly installed. Proceed to Test Step 3.
- Not OK

Repair: When the sensors are being installed, complete all of the following tasks:

- Lubricate the O ring with clean engine lubricating oil.
- Ensure that the sensor has a connector face seal inside the connector body. If a seal is damaged or missing, replace the seal.

- Ensure that the sensor is fully seated into the engine before tightening the bracket bolt.
- Ensure that the connector is latched on both sides.
- Ensure that the harness is properly secured, and ensure that the harness is attached to the harness clip.

1. Verify that the repair has eliminated the fault.

STOP.

Test Step 3. Measure the Sensor Resistance Through the Wiring Harness

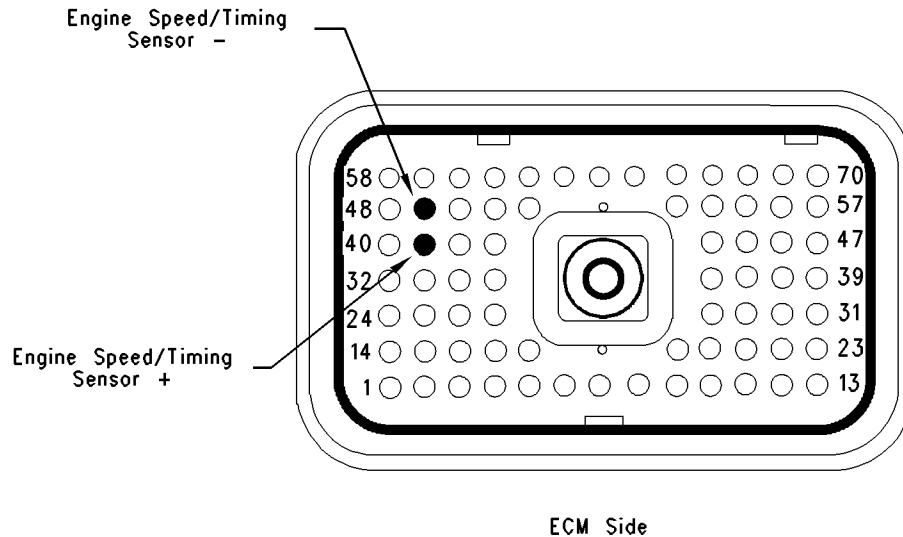

Illustration 79

g00887704

- A. Turn the keyswitch to the OFF position.
- B. Remove the P1 ECM connector.
- C. Use a multimeter to measure the resistance of the sensor from 41 terminal to 49 terminal.
- D. Wiggle the cables that are associated with the engine speed/timing sensor while the resistance is measured in order to check for an intermittent open or short circuit.

Refer to Illustration 79.

- E. The resistance between the terminals should be from 75 to 230 ohms.

Expected Result:

The readings agree with the values that are listed above.

Results:

- OK – Neither a short circuit nor an open circuit is indicated. Proceed to Test Step 5.
- Not OK – The resistance is not within the acceptable range when the circuit resistance is measured through the engine harness. Proceed to Test Step 4.

Test Step 4. Measure the Resistance of the Sensor

- A. Turn the keyswitch to the OFF position.
- B. Check the harness and the wiring for abrasion and pinch points from the sensor back to the ECM.
- C. Disconnect P401 engine speed/timing sensor connector.
- D. Thoroughly inspect the J401/P401 engine speed/timing sensor connector. Refer to Troubleshooting, “Electrical Connectors - Inspect”.
- E. The resistance between the terminals should be from 75 to 230 ohms.

Expected Result:

The readings agree with the values that are listed above.

Results:

- OK – The sensor resistance is within tolerance.

Repair: There is a fault in the cable between the P1 ECM connector and the P401 connector.

Repair the faulty cable or replace the faulty cable.

Verify that the repair has eliminated the faults.

STOP.

- Not OK – The sensor resistance is out of the nominal range.

Repair: Perform the following procedure in order to check and install the new sensor:

1. Before installing the new sensor, measure the resistance of the new sensor.

If the new sensor resistance is in the correct range, install the new sensor in the engine.

Ensure that the O ring is installed and free of damage.

Seat the sensor and tighten the setscrew.

If the sensor will not seat, repair the sensor or replace the sensor, as required.

Ensure that the sensor is properly oriented and that the harness is secured in the proper location.

2. Verify that the repair eliminates the problem.

STOP.

Test Step 5. Measure the Resistance of the Cables Between the Fuel Injection Pump and the ECM

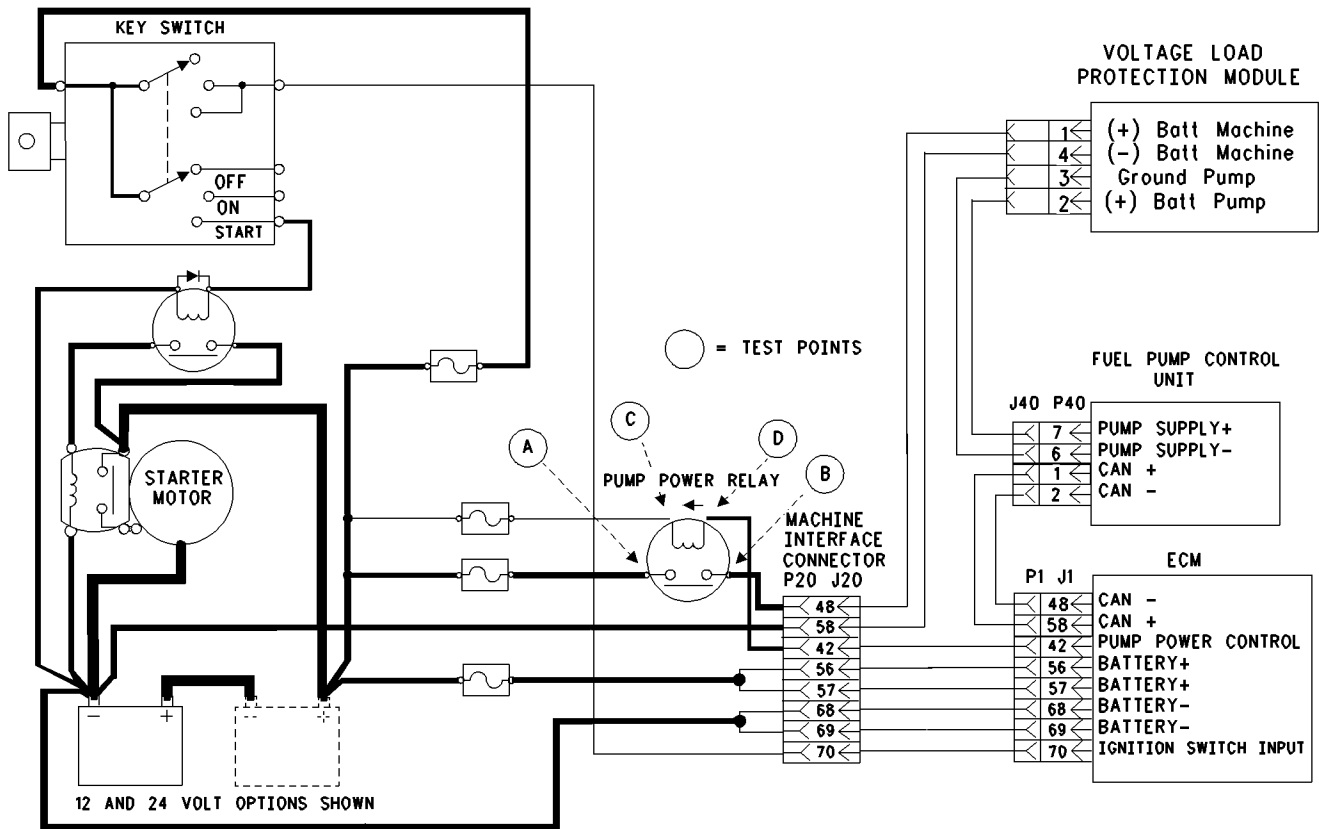

Illustration 80

g00910876

Schematic of the power supply for fuel injection pump

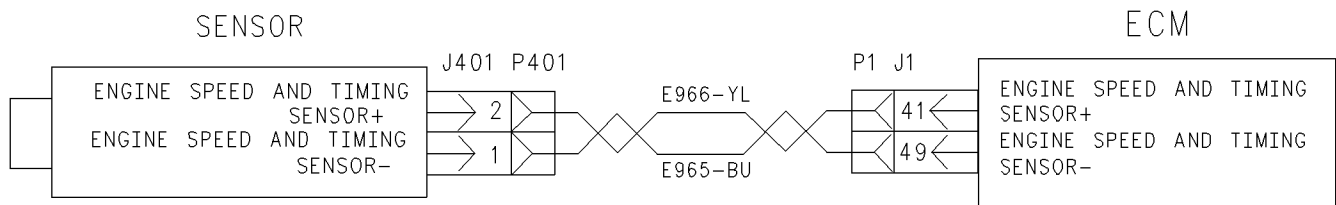

Illustration 81

g00835107

Schematic for the speed/timing sensor

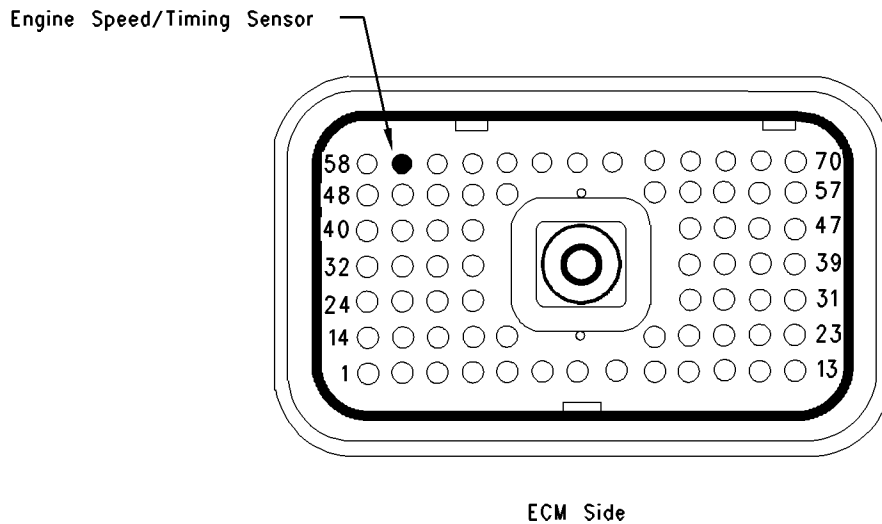

Illustration 82

g00885751

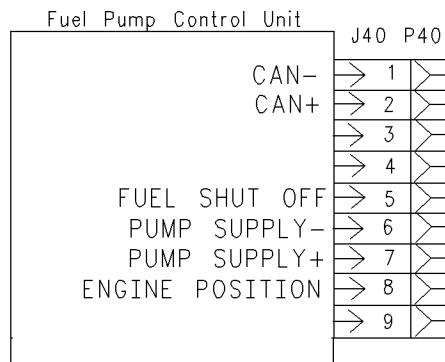

Illustration 83

g00863550

Fuel pump power supply

- A. Turn the keyswitch to the OFF position.
- B. Disconnect the P1 ECM connector and the P40 fuel injection pump connector.
- C. Measure the resistance from terminal 59 engine speed/timing sensor at the ECM and to terminal 8 engine speed/timing sensor of the P40 fuel injection pump connector.
- D. The resistance should be less than 2 ohms.

Expected Result:

The readings agree with the values that are listed above.

Results:

- OK – The ECM does not operate properly.

Repair: Perform the following repairs on the suspect ECM.

1. Temporarily install a test ECM.

Note: The test ECM should be programmed with the correct software. All parameters should be set to the same value as the suspect ECM.

2. If the fault is eliminated with the test ECM, reconnect the suspect ECM.
3. If the fault returns with the suspect ECM, then the suspect ECM is faulty. Replace the suspect ECM.

STOP.

- Not OK – The readings are higher than 2 ohms. Proceed to Test Step 6.

Test Step 6. Check the Continuity of the Cables From the ECM to the Fuel Injection Pump

- A. Turn the keyswitch to the OFF position.
- B. Disconnect the J1/P1 ECM connector and the J40/P40 fuel injection pump connector.

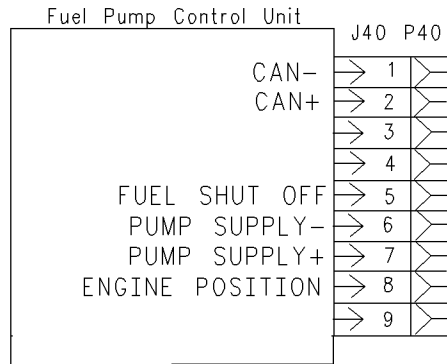

Illustration 84

g00863550

Fuel pump power supply

- C. Perform a continuity test between P40:8 fuel injection pump connector and the following terminals:
- P40:1
 - P40:2
 - P40:5
 - P40:6
 - P40:7

Expected Result:

The continuity check is positive.

Results:

- OK – There is a fault with the cables between the fuel injection pump and/or the ECM.

Repair: Replace the cable.

Verify that the repair eliminates the problem.

STOP.

- Not OK – The ECM is suspect.

Repair: Verify that the repair eliminates the problem.

1. Temporarily install a test ECM.

Note: The test ECM should be programmed with the correct software. All parameters should be set to the same value as the suspect ECM.

2. If the fault is eliminated with the test ECM, reconnect the suspect ECM.
3. If the fault returns with the suspect ECM, then the suspect ECM is faulty.
4. Replace the suspect ECM.

STOP.

i01798873

Engine Temperature Sensor Open or Short Circuit - Test

System Operation Description:

Use this procedure under the following conditions:

Use this procedure to troubleshoot the system only when there is an active diagnostic code or when a diagnostic code can easily be activated. This procedure covers open circuit diagnostic codes and short circuit diagnostic codes that are associated with the following sensors:

- Coolant temperature sensor
- Intake manifold air temperature sensor

The following background information is related to this procedure:

The troubleshooting procedures for the diagnostic codes of each temperature sensor are identical. The temperature sensors are sensors that have two terminals. The temperature sensors do not require supply voltage from the Electronic Control Module (ECM). ECM connector J1/P1 terminal 34 is the common connection for the engine temperature sensors. The sensor common connection is shared between all of the temperature sensors. The common line is connected to each sensor connector terminal 2. Terminal 1 is the sensor output. The signal voltage from terminal 1 of each sensor is supplied to the appropriate terminal at ECM Connector J1/P1.

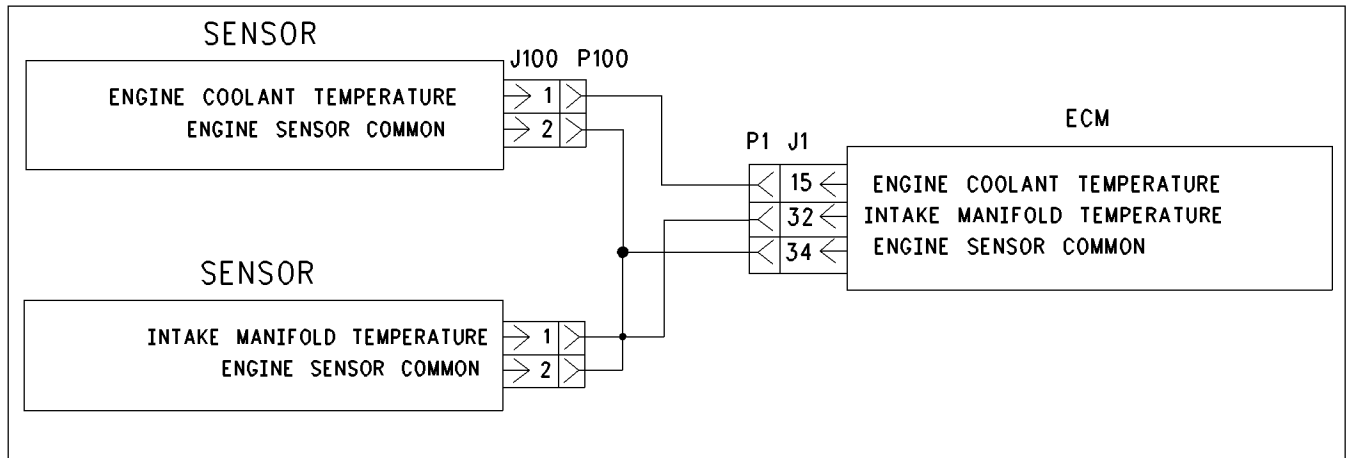

Illustration 85
Schematic for engine temperature sensors

g00955142

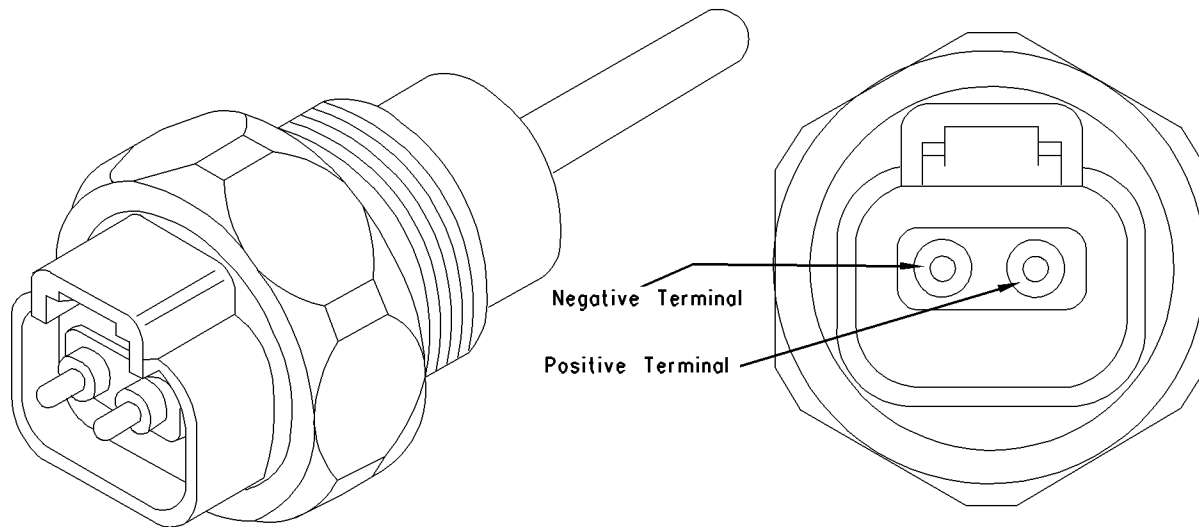

Illustration 86
Engine coolant temperature sensor and intake manifold air temperature sensor

g00835142

Test Step 1. Verify All Active Diagnostic Codes.

A. Connect the electronic service tool to the data link connector.

B. Turn the keyswitch to the ON position.

Note: Wait at least 15 seconds for activation of the diagnostic codes.

C. Use the electronic service tool in order to verify if any of the following diagnostic codes are active:

- 105-03 Intake Manifold Temperature Sensor Open Circuit or Shorted High
- 105-04 Intake Manifold Temperature Sensor Shorted Low
- 110-03 Engine Coolant Temperature Sensor Open Circuit or Shorted High
- 110-04 Engine Coolant Temperature Sensor Shorted Low

Expected Result:

One or more of the preceding diagnostic codes are active.

Results:

- Yes – Proceed to Test Step 2.
- No

Repair: If the preceding codes are logged but not active and the engine is not running properly, refer to Troubleshooting, “Troubleshooting without a Diagnostic Code”. If the engine is running properly at this time, an intermittent condition may be causing the logged codes. Refer to Troubleshooting, “Electrical Connections - Inspect”.

STOP.

Test Step 2. Inspect Electrical Connectors And Wiring.

Illustration 87

g00955143

- Thoroughly inspect ECM engine harness connector J1/P1 and the suspect sensor connector. Refer to Troubleshooting, “Electrical Connectors - Inspect”.
- Perform a 45 N (10 lb) pull test on each of the wires in the sensor connector and the ECM connector that are associated with the active diagnostic code.

Refer to Illustration 87.

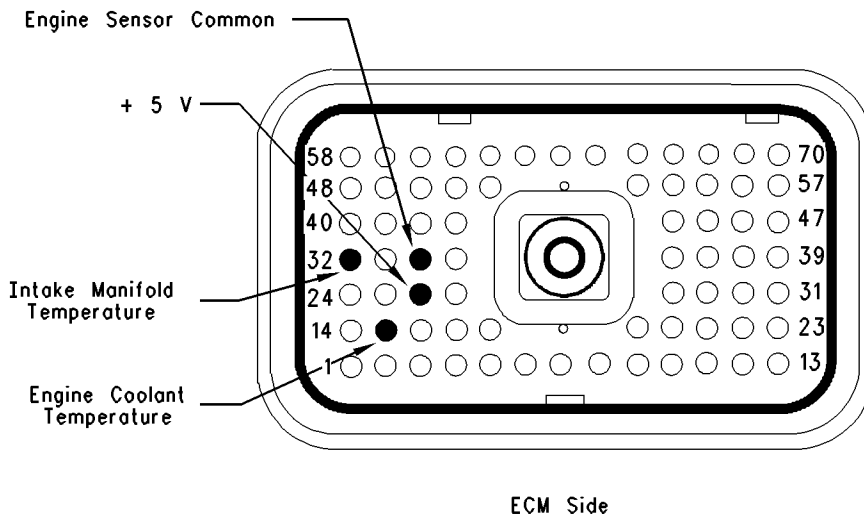
- Verify that the latch tab of the connector is properly latched. Also verify that the latch tab of the connector has returned to the fully latching position.
- Check the ECM connector (Allen head screw) for the proper torque of 6.0 N·m (55 lb in).

- E. Check the harness and wiring for abrasions and for pinch points from the sensor to the ECM.

Expected Result:

All connectors, pins, and sockets should be completely coupled and/or inserted. The harness and wiring should be free of corrosion, abrasion, and pinch points.

Results:

- OK – Proceed to Test Step 3.
- Not OK – Repair the connectors or wiring and/or replace the connectors or wiring. Ensure that all of the seals are properly in place and ensure that the connectors are completely coupled. Clear all inactive diagnostic codes. Verify that the repair has eliminated the problem. Proceed to test step 3 if the fault has not been eliminated.

Test Step 3. Verify That The Diagnostic Code Is Still Active.

- A. Turn the keyswitch to the ON position.

Note: Wait at least 15 seconds for activation of the diagnostic codes.

- B. Access the “Active Diagnostic Code” screen on the electronic service tool and check for active diagnostic codes.
- C. Determine if the problem is related to an open circuit diagnostic code or a short circuit diagnostic code.

Expected Result:

A short circuit diagnostic code or an open circuit diagnostic code is active.

Results:

- SHORT Circuit – A short circuit diagnostic code is active at this time. Proceed to Test Step 4.
- OPEN Circuit – An open circuit diagnostic code is active at this time. Proceed to Test Step 5.

Test Step 4. Disconnect The Sensor In Order To Create An Open Circuit.

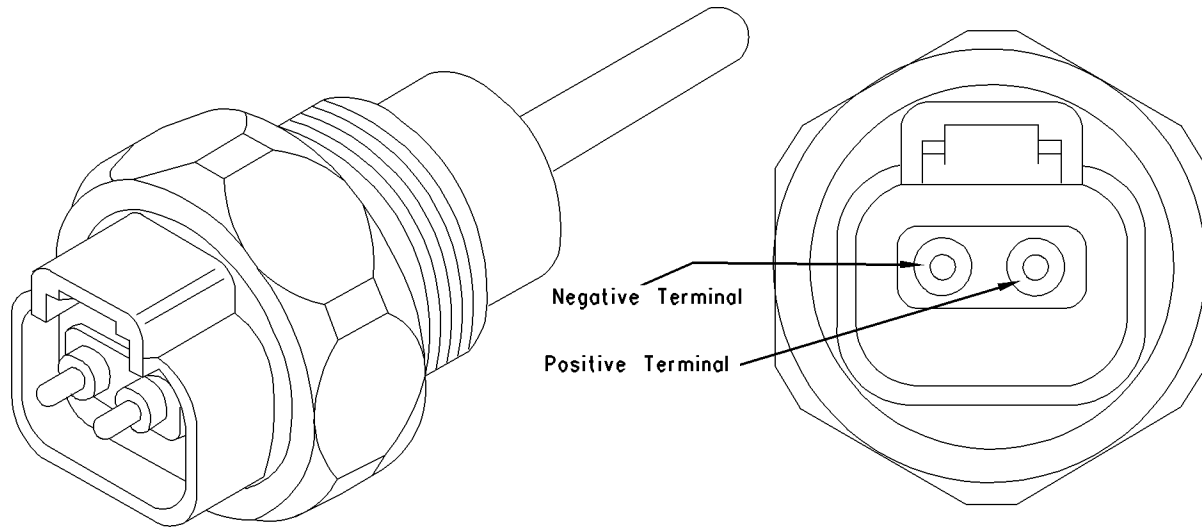

Illustration 88

g00835142

Engine coolant temperature sensor

- A. Turn the keyswitch to the OFF position.
 - B. Disconnect the sensor connector of the sensor with the short circuit diagnostic code.
 - C. Turn the keyswitch to the ON position.
- Note:** Wait at least 15 seconds for activation of the diagnostic codes.
- D. Access the “Active Diagnostic Code” screen of the electronic service tool. Check for an active open circuit diagnostic code.

Expected Result:

An open circuit diagnostic code for the disconnected sensor is now active.

Results:

- OK – A short circuit diagnostic code was active before disconnecting the sensor. An open circuit diagnostic code became active after disconnecting the sensor.

Repair: Refer to Troubleshooting, “Electrical Connectors - Inspect”.

Inspect the seals of the connectors for damage.

Connect the sensor and verify that the fault returns. If the fault returns, the sensor is faulty.

Replace the sensor.

Remove all inactive diagnostic fault codes.

STOP.

- Not OK – There is a short circuit between the sensor harness connector and the ECM. Leave the sensor disconnected. Proceed to Test Step 6.

Test Step 5. Create A Short Circuit Between The Signal And The Common Terminals At The Sensor Harness Connector.

- A. Turn the keyswitch to the ON position.

Note: Wait at least 15 seconds for the activation of any diagnostic fault codes.

- B. Fabricate a jumper wire 150 mm (6 inch) long. Crimp a Deutsch terminal to both ends of the wire.
- C. Monitor the “Active Diagnostic Code” screen on the electronic service tool before installing the jumper wire and after installing the jumper wire.
- D. Install the jumper on the engine harness connector. Install one end of the jumper at the sensor signal (positive terminal). Install the other end of the jumper at the common connection for the engine temperature sensor (terminal 2).

Note: Wait at least 15 seconds for activation of the short circuit diagnostic code.

Expected Result:

A short circuit diagnostic code is active when the jumper is installed. An open circuit diagnostic code is active when the jumper is removed.

Results:

- OK – The engine harness and the ECM are OK.

Repair: Perform the following repair:

1. Temporarily connect the suspect sensor.
2. If the diagnostic code remains active, replace the sensor.
3. Verify that the repair eliminates the problem.
4. Clear all inactive diagnostic codes.

STOP.

- Not OK – The open circuit diagnostic code remains active with the jumper in place. The most probable location for the open is in the sensor common or the sensor signal wire in the engine harness between the ECM and the sensor. Remove the jumper. Proceed to Test Step 6.

Test Step 6. Check The Operation Of The ECM By Creating An Open And A Short Circuit At The ECM Connector.

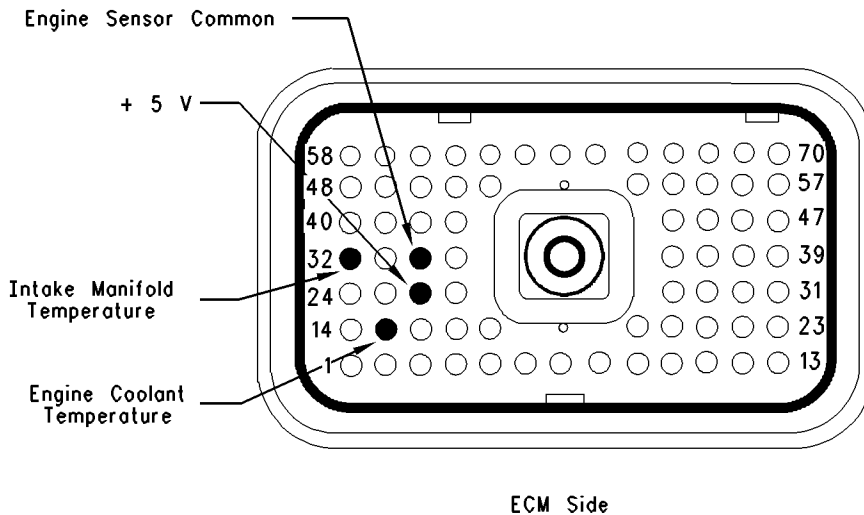

Illustration 89

g00955143

- A.** Turn the keyswitch to the OFF position.
- B.** Disconnect the J1/P1 ECM connector.
- C.** Disconnect the connector for the ECM harness. Thoroughly inspect both halves of the connector for signs of corrosion or moisture. Refer to Troubleshooting, “Electrical Connectors - Inspect”.
- D.** Turn the keyswitch to the ON position. Use the electronic service tool in order to monitor the “Active Diagnostic Code” screen. Wait at least 15 seconds for activation of the code.
- An open circuit diagnostic code should be active for the suspect sensor.
- Note:** When the engine harness is disconnected, all of the open circuit diagnostic codes for the pressure sensors will be active. This is normal. Disregard the diagnostic codes for the pressure sensors.
- E.** Turn the keyswitch to the OFF position.
- F.** Fabricate a jumper wire 150 mm (6 inch) long. Crimp a Deutsch terminal to both ends of the wire.
- G.** Monitor the “Active Diagnostic Code” screen on the electronic service tool before installing the jumper wire and after installing the jumper wire.

- H.** Install the jumper on the engine harness connector. Install one end of the jumper at the sensor signal on the bypass harness. Install the other end of the jumper at the terminal 34 common connection for the bypass harness. Wait at least 15 seconds for activation of the short circuit diagnostic code.

Expected Result:

A short circuit diagnostic code is active when the jumper is installed. An open circuit diagnostic code is active when the jumper is removed.

Results:

- OK – Verify that the repair eliminates the problem. Use the electronic service tool to clear the logged diagnostic codes. Proceed to test step 7.
- Not OK

Repair: The ECM does not operate correctly.

1. Temporarily connect a test ECM.

Note: The test ECM should be programmed with the correct software. All parameters should be set to the same value of the suspect ECM.

2. Remove all jumpers and replace all connectors.
3. If the fault is eliminated with the test ECM, install the suspect ECM and verify that the fault returns.
4. If the fault returns replace the suspect ECM.
5. Verify that the repair eliminates the problem.

STOP.

Test Step 7. Bypass The Harness Wiring Between The ECM And The Sensor Connector.

- A. Turn the keyswitch to the OFF position.
- B. Disconnect the J1/P1 connector for the ECM harness, and the suspect sensor connector.
- C. Remove the sensor signal wire from the P1 ECM connector.
- D. Remove the signal wire (positive terminal) from the sensor connector on the engine harness.
- E. Fabricate a jumper wire that is long enough to reach from the ECM to the sensor connector with Deutsch sockets on both ends.
- F. Insert one end of the jumper into the ECM connector. Insert the other end of the jumper into the sensor connector of the engine harness.
- G. Reconnect the connector for the ECM harness and the sensor connector.
- H. Turn the keyswitch to the ON position.
- I. Use the electronic service tool in order to monitor the "Active Diagnostic Code" screen for either the open circuit diagnostic code for the sensor or the short circuit diagnostic code for the sensor.

Expected Result:

The diagnostic code disappears when the jumper is installed.

Results:

- OK – There is a problem in the wiring harness.

Repair: Perform the following repair:

1. Repair the faulty wiring harness or replace the faulty wiring harness.
2. Clear all diagnostic codes.

3. Verify that the repair eliminates the problem.

STOP.

- Not OK – Restart this procedure and carefully perform each step. STOP.

i01798874

Fuel Injection Pump Circuit - Test

System Operation Description:

Use this procedure under the following conditions:

Note: The Bosch VP30 fuel injection pump is installed on the engine at the factory. The pump is not serviceable.

Use this procedure if another procedure has directed you here. Also use this procedure if any of the following diagnostic codes are active:

- 1684-04 Fuel Injection Pump supply voltage fault
- 1684-07 Fuel Injection Pump mechanical fault
- 1684-11 Fuel Injection Pump internal sensor fault
- 1684-14 Fuel Injection Pump no communications
- 174-02 Fuel Temperature Sensor erratic or intermittent
- 342-02 Speed and Timing Sensor No.2 intermittent signal

The following background information is related to this procedure:

The fuel injection pump receives an electrical supply from the OEM cables and from the relay for the fuel injection pump through the Machine Interface Connector (MIC).

The loss of power to the fuel injection pump can occur on either the positive side or the negative side of the pump. The positive side is supplied from the pump power relay to the fuel injection pump. The positive supply includes a fuse in order to protect the circuit. The negative side is connected directly to the battery.

Note: The engine protection system (if equipped) and the engine shutdown system (if equipped) have the ability to disconnect the electrical power from the fuel injection pump. The engine protection system will disconnect the electrical power supply to the Electronic Control Module (ECM). The loss of electrical power to the engine will cause the engine to shutdown. The engine protection devices can be the problem when the engine is difficult to start. Some engine protection systems will not supply power to the system until the crankshaft rotates, and the oil pressure achieves a safe level, or until an override button is activated. These devices may be the cause of intermittent power loss or no power to the fuel injection pump.

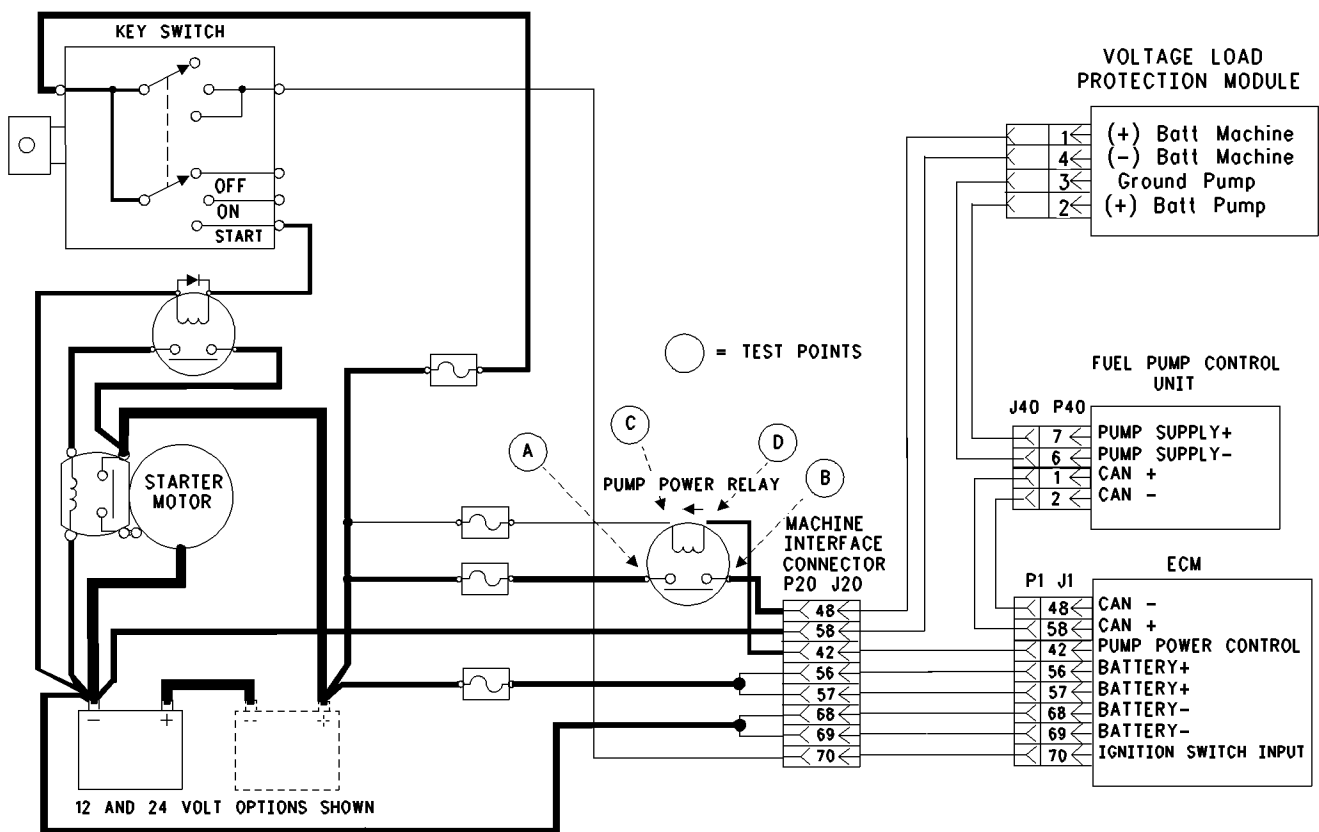

Illustration 90
Schematic for the fuel injection pump

Electronically Controlled Fuel System

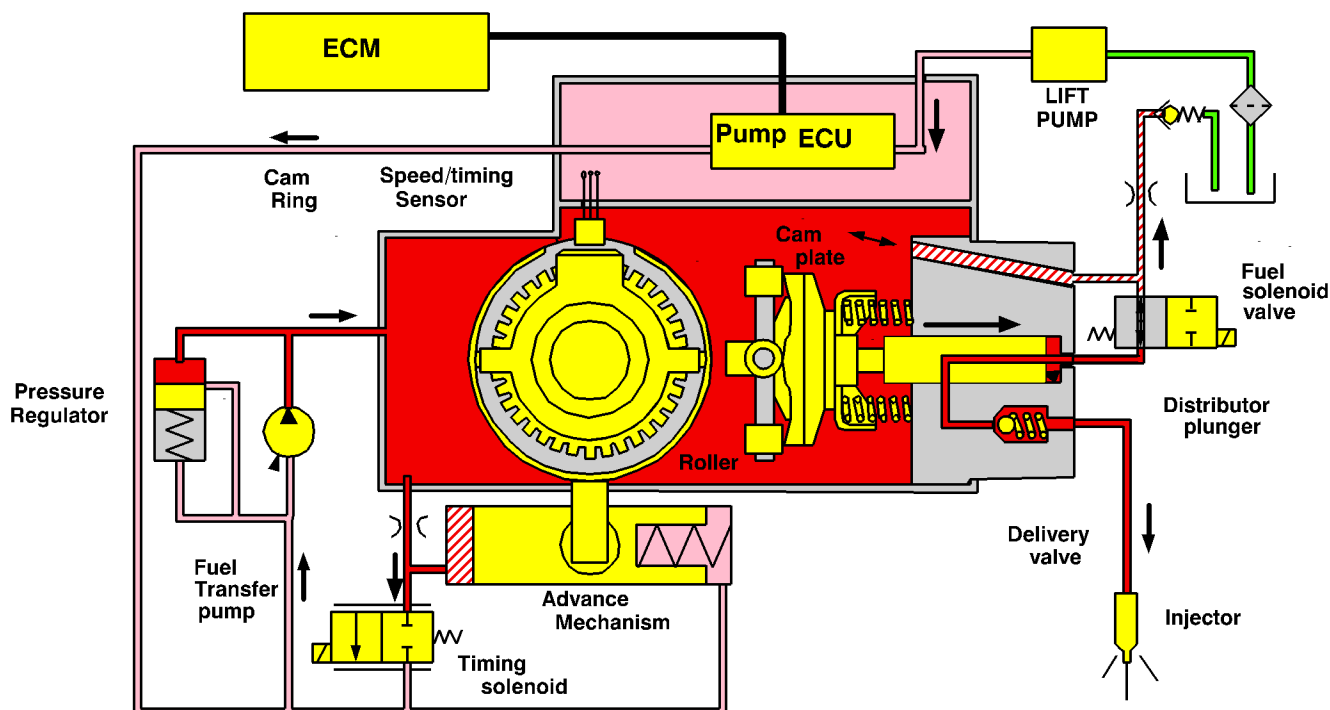

Illustration 91
Schematic for the electronically controlled fuel system

g00908788

Test Step 1. Check the Batteries

A. Measure no-load battery voltage at the battery terminals.

Expected Result:

The battery voltage should be no less than 11.0 volts for a 12 volt system.

The battery voltage should be no less than 22.0 volts for a 24 volt system.

Results:

- OK – Proceed to Test Step 2.
- Not OK

Repair: Recharge the batteries or replace the batteries. Verify that the repairs have eliminated the problem.

STOP.

Test Step 2. Inspect the Electrical Connectors and Wiring

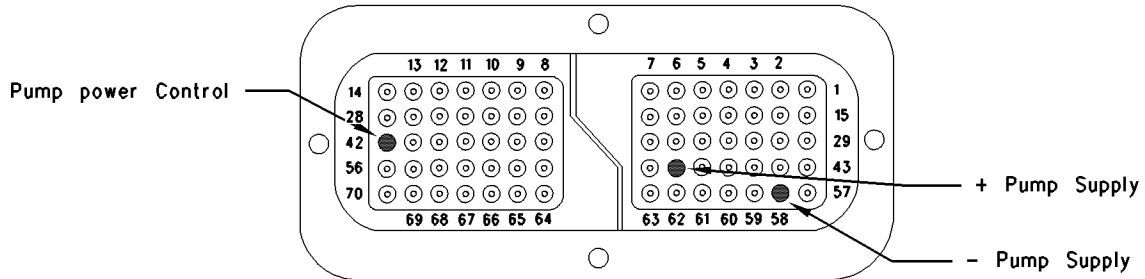

Illustration 92
Connections in the machine interface connector for the fuel injection pump

g00856174

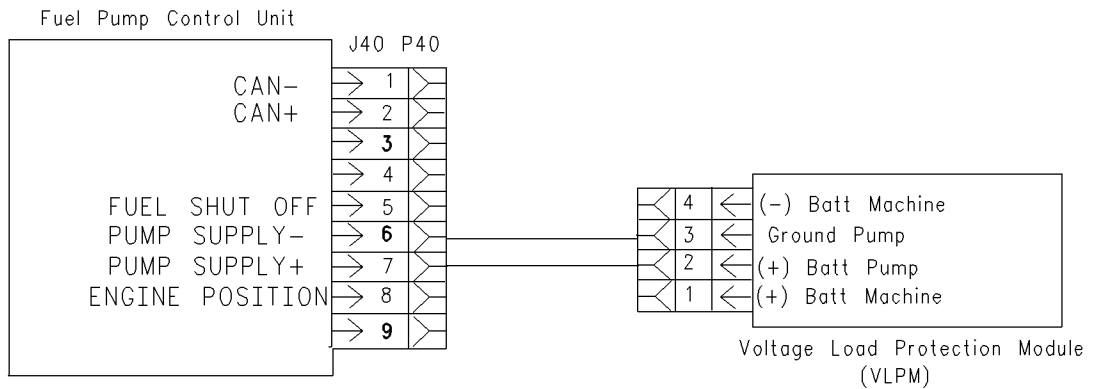

Illustration 93
P40/J40 Fuel injection pump connector and the VLPM

g00908748

A. Thoroughly inspect the following terminal connections on the P40 Fuel Injection Pump Connector:

- P40:6 - Pump Supply
- P40:7 + Pump Supply

Refer to Troubleshooting, “Electrical Connectors - Inspect”.

B. Thoroughly inspect the following terminal connections on the P20/J20 Machine Interface Connector.

- P20: 58 - Pump Supply
- P20: 48 + Pump Supply
- P20: 42 Pump Power Control

C. Perform a 45 N (10 lb) pull test on each of the wires in the Machine Interface Connector that are associated with the following connections:

- P20:58 - Pump Supply
- P20:48 + Pump Supply
- P20:42 Pump Power Control

D. Check the ECM connector (Allen head screw) for the proper torque of 6.0 N·m (55 lb in).

E. Check the harness and wiring for abrasions and for pinch points from the battery to the ECM. Also, check the harness and wiring for abrasions and for pinch points from the keyswitch to the ECM.

Expected Result:

All connectors, pins, and sockets should be completely coupled and/or inserted. The harness and wiring should be free of corrosion, abrasion, and/or pinch points.

Results:

- OK – Proceed to Test Step 3.
- Not OK – There is a problem with the wiring or connectors. Repair the wiring and/or connectors or replace the wiring and/or connectors. Verify that the repair has eliminated the problem. STOP.

Test Step 3. Check the Supply Voltage at the Machine Interface Connector

Breakout T Connector

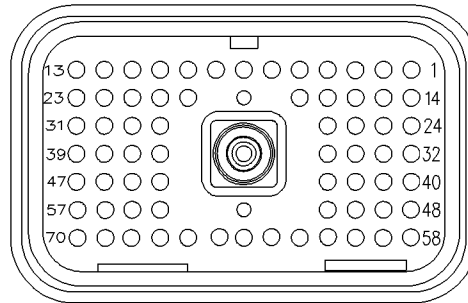

Illustration 94
Breakout T

g00856527

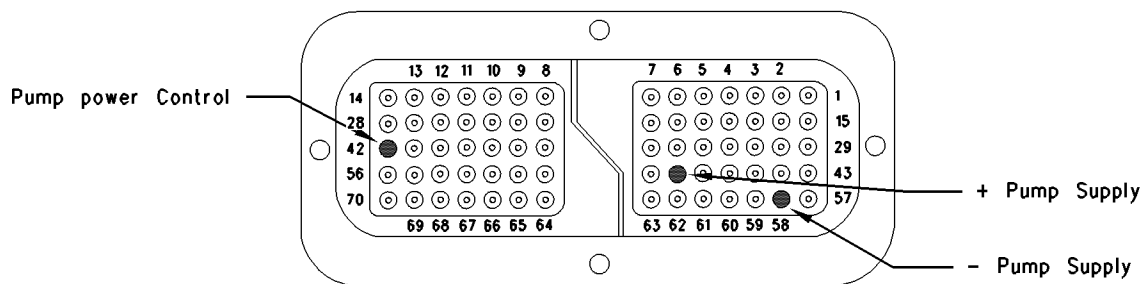

Illustration 95

g00856174

Connections in the J20/P20 Machine Interface Connector for the fuel injection pump

- A.** Disconnect the machine interface connector P20 from ECM connector J1 and insert a 70 Pin Breakout T.
- B.** Reconnect the harness.
- C.** Turn the keyswitch to the ON position.
- D.** Measure the voltage between P20:48 + Pump Supply and P20:58 - Pump Supply.

Expected Result:

The measured voltage is between 11.0 VDC and 13.5 VDC for a 12 volt system and between 22.0 VDC and 27.0 VDC for a 24 volt system with no suspected intermittent problems at this time.

Results:

- OK – Proceed to Test Step 4.
- Intermittent voltage or no voltage – Proceed to Test Step 5.
- Voltage is out of range

Repair: The problem is in the wiring for the machine interface connector. Repair the wire harness or replace the wire harness. Verify that the repair has eliminated the problem.

STOP.

Test Step 4. Check the Supply Voltage at the Fuel Injection Pump

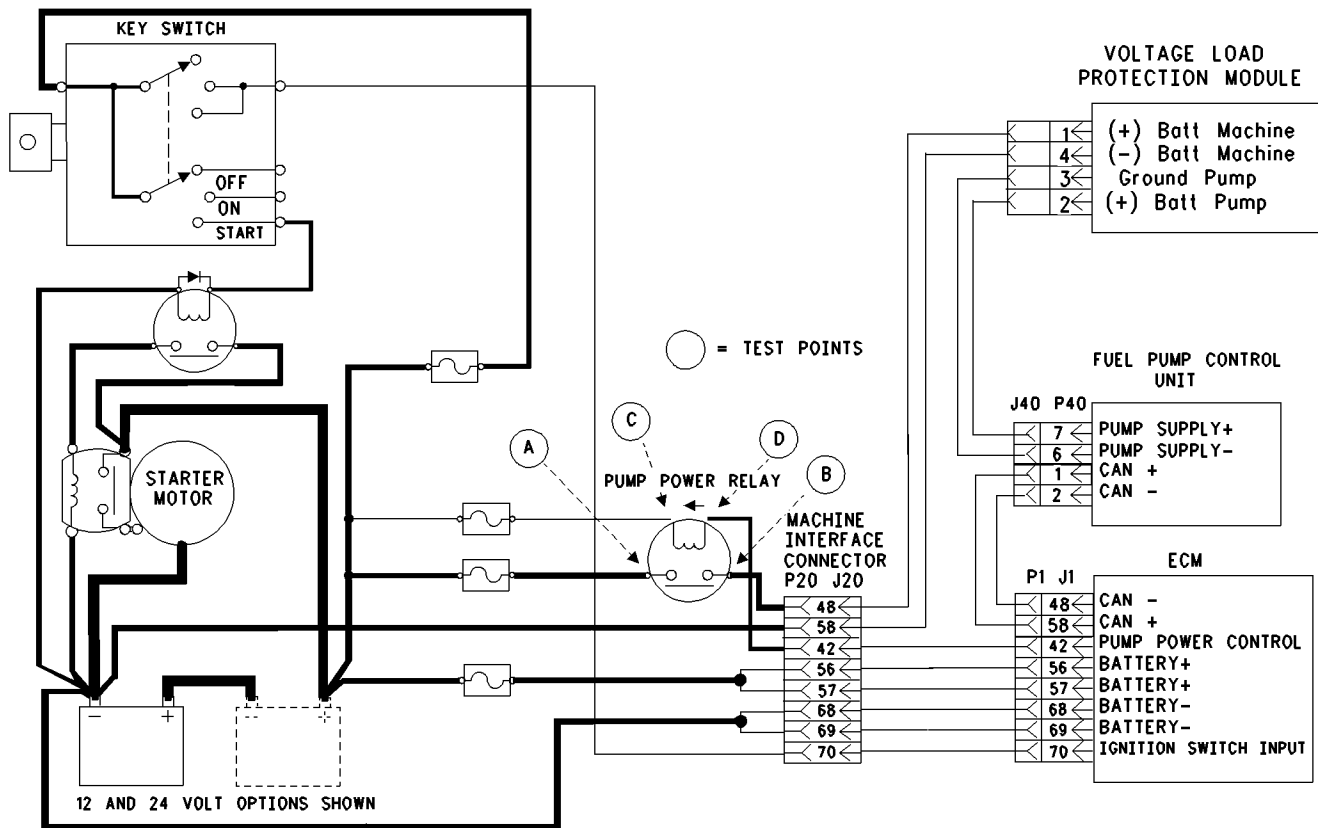

Illustration 96
Schematic for the fuel injection pump and the ECM power supply

g00910876

- A. Turn the Keyswitch to the OFF position.
- B. Disconnect the P40 connector from the fuel injection pump.
- C. Turn the keyswitch to the ON position.
- D. Measure the voltage between P40:7 + Pump Supply and P40:6 - Pump Supply.

Expected Result:

The measured voltage is between 11.0 VDC and 13.5 VDC for a 12 volt system and between 22.0 VDC and 27.0 VDC for a 24 volt system with no suspected intermittent problems at this time.

Results:

- OK

Repair: The wiring harness and the voltage supply to the fuel injection pump are correct. The problem is in the fuel injection pump or there is a communication problem between the ECM and the fuel injection pump. Refer to Troubleshooting, "CAN Data Link Circuit - Test". If the CAN Data Link is correct the problem is in the fuel injection pump. Contact the Perkins Technical Support Centre in order to check if the software version is correct. Also check that there have been no software updates. If the problem still exists contact the Perkins Technical Support Centre in order to change the fuel injection pump. The warranty of the fuel injection pump will be affected if the pump is replaced without prior consultation. Replace the fuel injection pump. Refer to Disassembly and Assembly, "Fuel Injection Pump Remove and Install". Check for active diagnostic codes.

STOP.

- Intermittent voltage or the voltage is out of range

Repair: There is a problem in the wiring between J20 connector and J40 connector. Repair the wiring or replace the wiring. Verify that the repair has eliminated the problem.

STOP.

Test Step 5. Check the Supply to the Power Relay for the Fuel Injection Pump

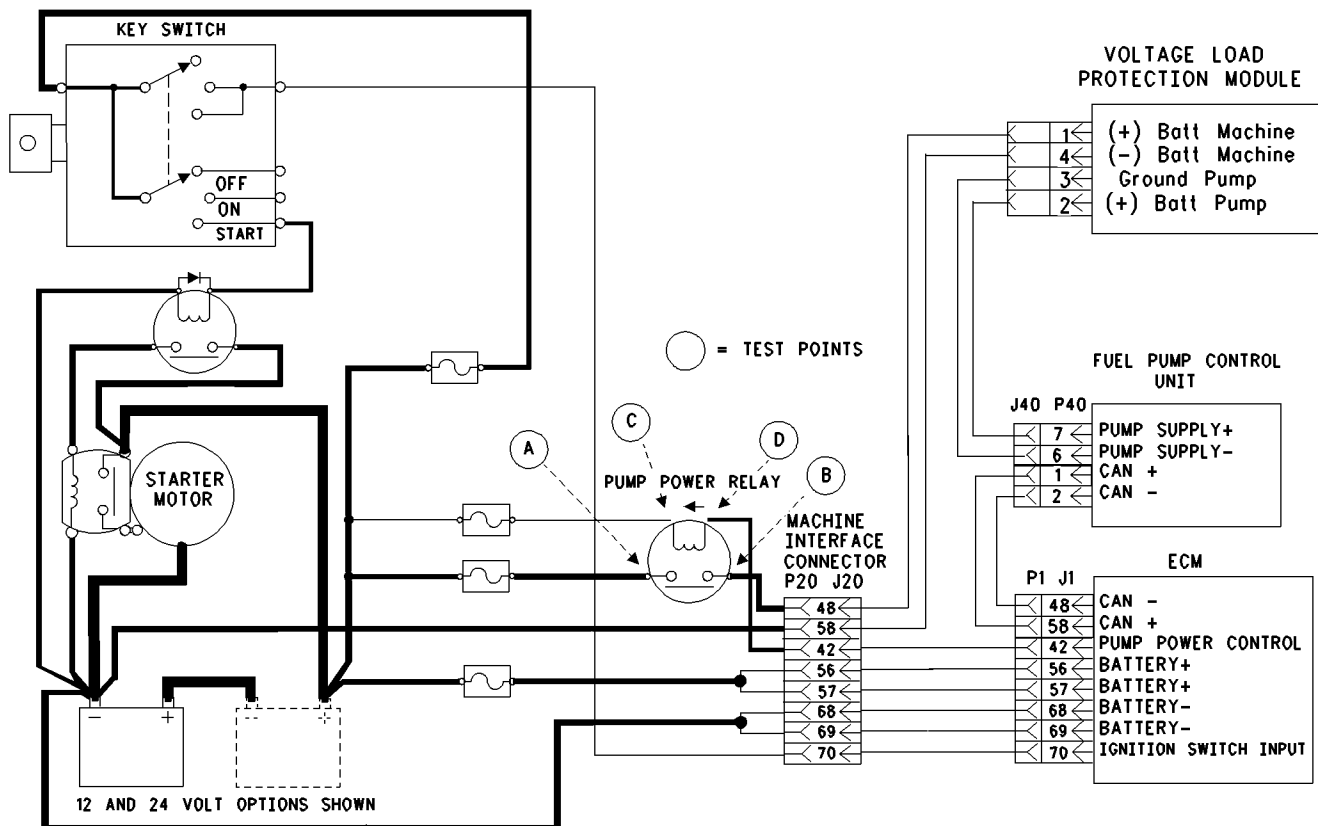

Illustration 97

g00910876

Schematic for the fuel injection pump and the ECM power supply

- Turn the keyswitch to the ON position.
- Measure the voltage between the following contacts:
 - A and P1:68
 - B and P1:68
 - C and P1:68
 - C and P1:69
 - D and P1:69

Expected Result:

The measured voltage is between 11.0 VDC and 13.5 VDC for a 12 volt system and between 22.0 VDC and 27.0 VDC for a 24 volt system with the keyswitch in the ON position and 0 VDC with the keyswitch in the OFF position.

Results:

- OK – Proceed to Test Step 6.
- Not OK

Repair: There is a problem with the wires between the battery and the fuel injection pump. Repair the wires or replace the wires. Verify that the repairs have eliminated the problem.

STOP.

Test Step 6. Check the Output of the Power Relay for the Fuel Injection Pump

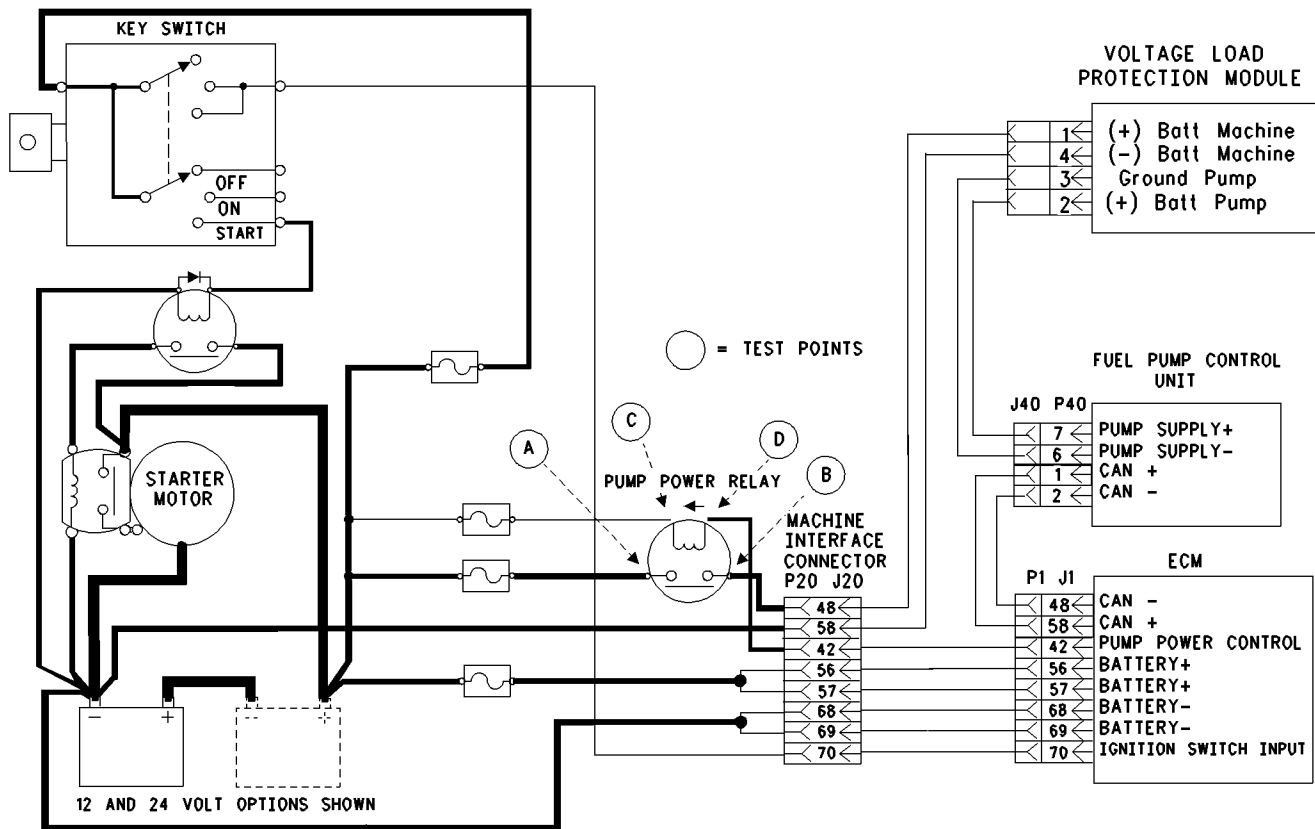

Illustration 98
Schematic for the fuel injection pump and the ECM power supply

g00910876

- A. Turn the keyswitch to the ON position.
- B. Measure the voltage between the switched side of the fuel injection pump and the negative side of the battery.
- C. Turn the keyswitch to the OFF position.
- D. Measure the voltage between the switched side of the fuel injection pump and the negative side of the battery.

Expected Result:

The measured voltage is between 11.0 VDC and 13.5 VDC for a 12 volt system and between 22.0 VDC and 27.0 VDC for a 24 volt system with no suspected intermittent problems at this time.

Results:

- OK

Repair: There is a problem with the wiring between the fuel pump power relay and the machine interface connector P20. Repair the wiring or replace the wiring. Verify that the repair has eliminated the problem.

STOP.

- Not OK

Repair: There is no voltage or the voltage is out of the acceptable range.

Proceed to Test Step 7.

Test Step 7. Check the Voltage at the Relay Coil for the Fuel Injection Pump

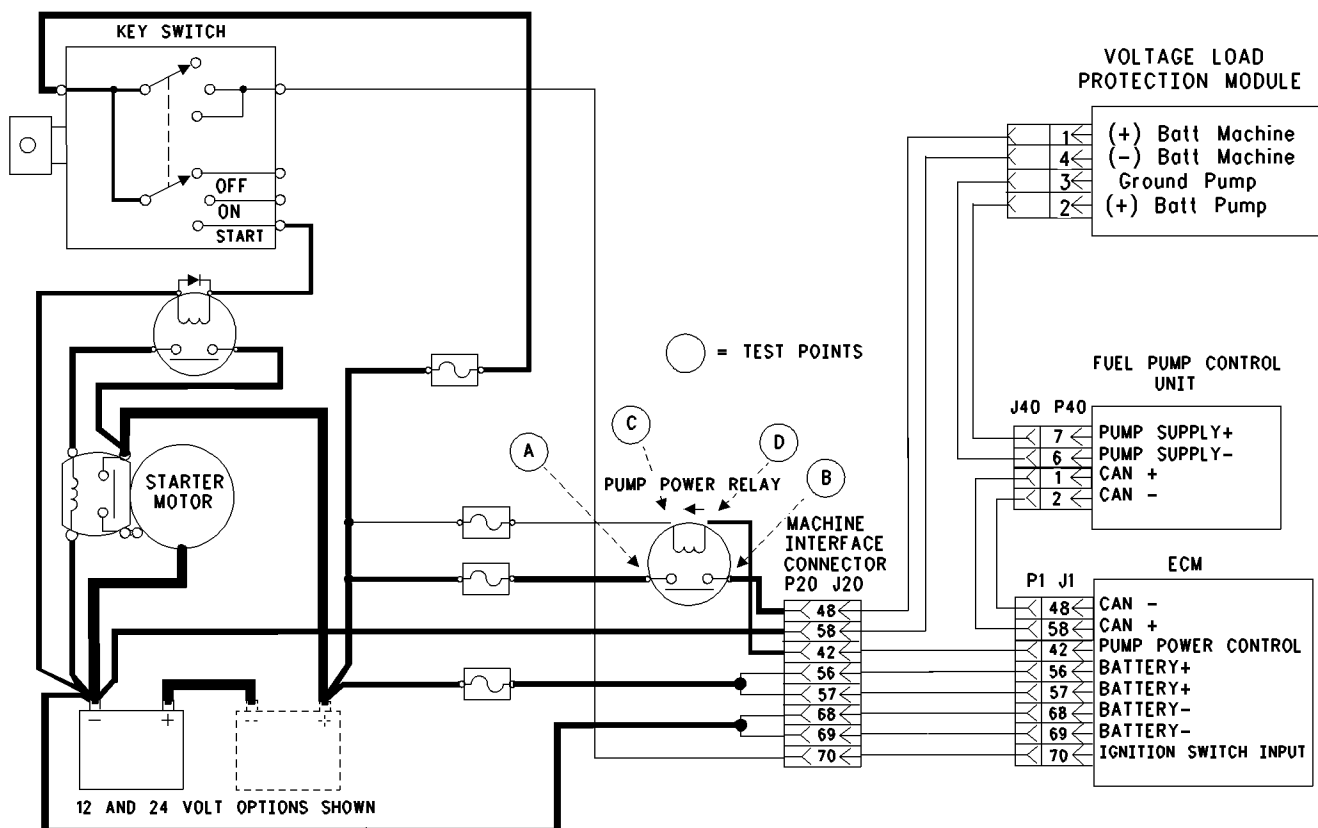

Illustration 99

g00910876

Schematic for the fuel injection pump and the ECM power supply

- Turn the keyswitch to the ON position.
- Measure the voltage between terminal C and terminal D.
- Refer to illustration 99.

- Turn the keyswitch to the OFF position and then turn the keyswitch to the ON position.

Note: The relay should emit a clicking sound as the keyswitch is turned to the ON position.

- Check that the voltage is present with the keyswitch in the ON position.

- F. Check that there is no voltage with the keyswitch in the OFF position.

Expected Result:

The measured voltage is between 11.0 VDC and 13.5 VDC for a 12 volt system and between 22.0 VDC and 27.0 VDC for a 24 volt system with no suspected intermittent problems at this time.

Results:

- OK

Repair: There is a problem with the relay. Replace the relay and verify that the repair has eliminated the problem.

STOP.

- Not OK – There is no voltage or the voltage is out of the acceptable range. Proceed to Test Step 8.

Test Step 8. Check the Output of the ECM Fuel Pump Power Control at the Machine Interface Connector

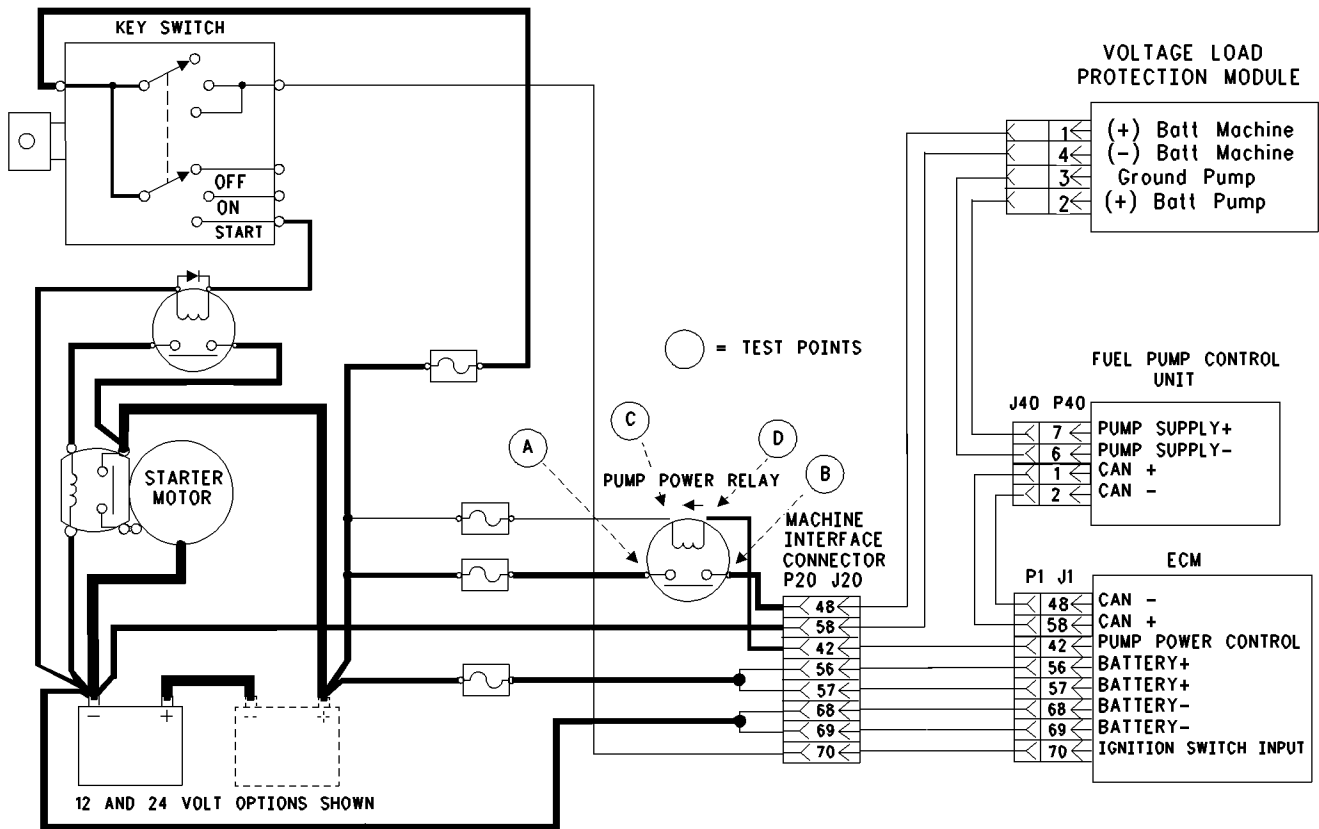

Illustration 100
Schematic for the fuel injection pump and the ECM power supply

g00910876

Breakout T Connector

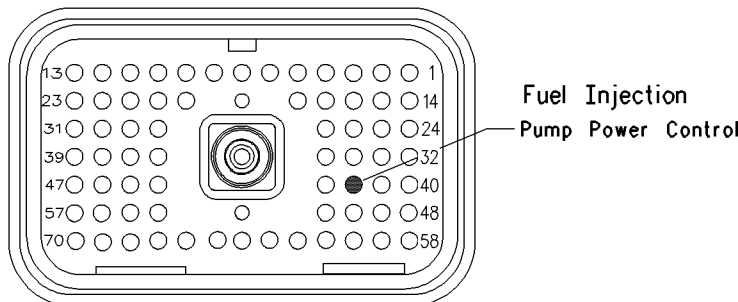

Illustration 101
Breakout T

g00955177

- A. Disconnect P20 MIC.
- B. Connect a Breakout T between P20 and J20.
- C. Turn the keyswitch to the ON position.
- D. Measure the voltage between the positive side of the fuel injection pump Test Point C power relay coil and terminal 42 of the Breakout T.
- E. Refer to illustration 100 and illustration 101.

Expected Result:

The measured voltage is between 11.0 VDC and 13.5 VDC for a 12 volt system and between 22.0 VDC and 27.0 VDC for a 24 volt system with no suspected intermittent problems at this time.

Results:

- OK

Repair: There is a problem with the wires between the relay and the P20 MIC.

Repair the wiring or replace the wiring. Verify that the repair has eliminated the problem.

STOP.

- Not OK – Proceed to Test Step 9.

Test Step 9. Check the Output of the Fuel Injection Pump Power Control at the ECM

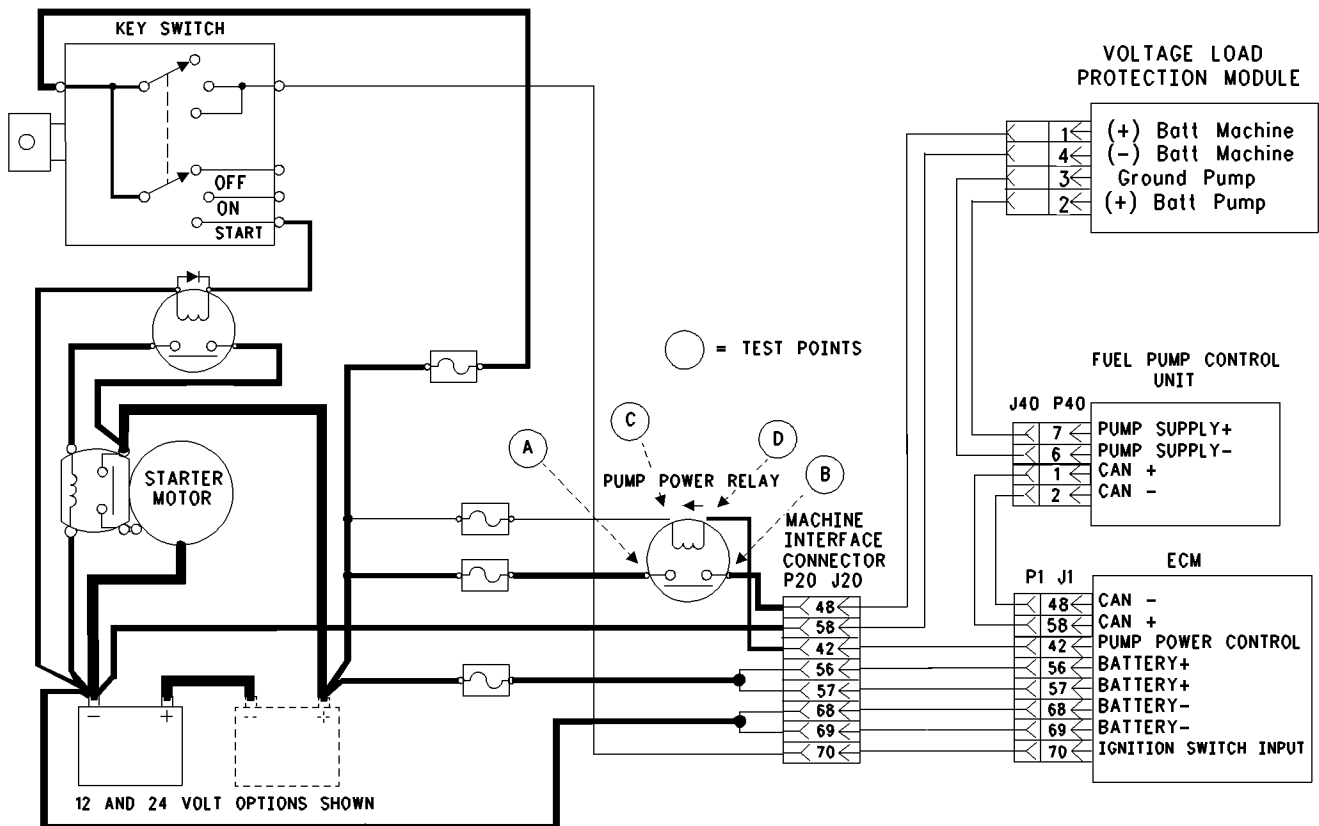

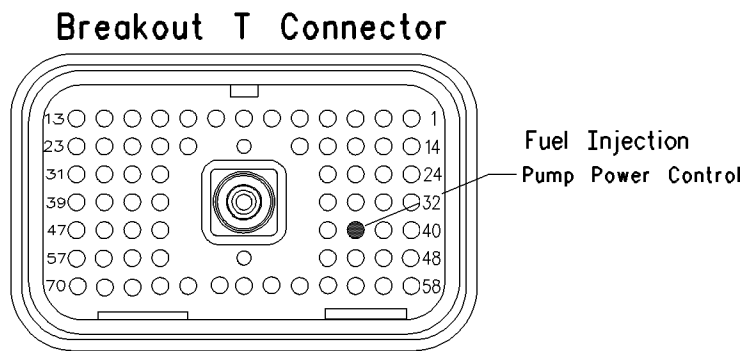

Illustration 103

g00955177

Breakout T

- A. Turn the keyswitch to the OFF position.
- B. Disconnect P1 ECM connector.
- C. Connect a Breakout T between P1 ECM connector and J1.
- D. Measure the voltage between Test Point C relay coil and terminal 42 on the Breakout T. Refer to illustrations 102 and 103.
- E. Check that the voltage is present with the keyswitch in the ON position.
- F. Check that there is no voltage with the keyswitch in the OFF position.

Expected Result:

The measured voltage is between 11.0 VDC and 13.5 VDC for a 12 volt system and between 22.0 VDC and 27.0 VDC for a 24 volt system with no suspected intermittent problems at this time.

Results:

- OK – There is a problem in the wiring between P1 and P20.

Repair: Repair the wiring or replace the wiring. Verify that the repair has eliminated the problem.

STOP.

- Not OK – There is a problem with the ECM supply/ignition switch input.

Repair: Refer to Troubleshooting, “Electrical Power Supply Circuit - Test”.

STOP.

Test Step 10. Measure the Voltage at the Pump Power Supply

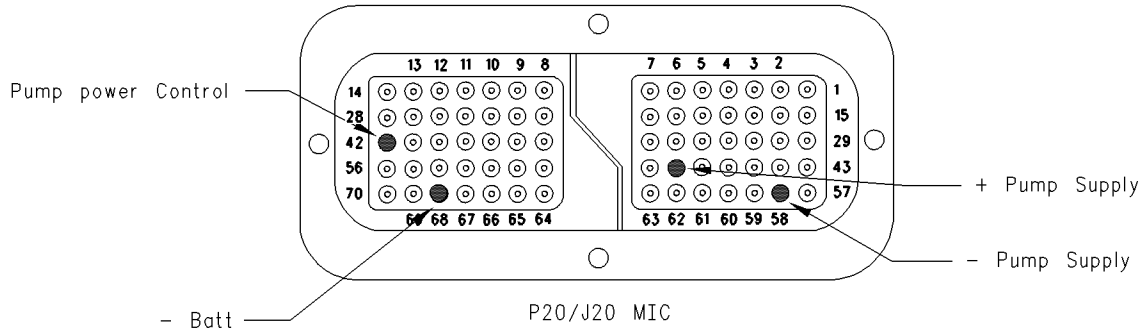

Illustration 104

g00907932

Connections for the J20/P20 machine interface connector and the power supply for the fuel injection pump

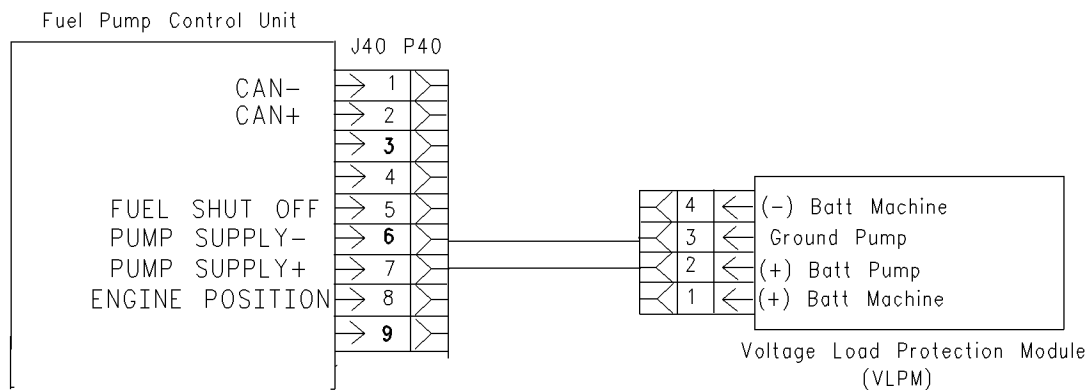

Illustration 105

g00907931

Connections for the fuel injection pump control unit and VLPM

Note: This test is designed to measure the resistance of the pump power supply by allowing a current to flow through the supply circuit and measuring the voltage drop.

A. Remove the following wires from the P20/J20 machine interface connector:

- P20:48 + Machine Batt
- P20:58 - Machine Batt
- P20:42 Fuel Pump Power Control
- P20:68 - Batt

B. Insert a resistor into the following “MIC” pin connections:

- P20:48
- P20:58

C. Connect a switch to P20:42 and P20:68. All connectors, pins, and sockets should be completely coupled and/or inserted.

D. Connect a multimeter and ensure that the voltage is 0 volts while the switch is in the “OPEN” condition.

E. Turn the switch to the OFF position and record the voltage.

Expected Result:

The resistance is less than 50 m ohms for a 12 V application.

The resistance is less than 80 m ohms for a 24 V application.

Results:

- OK – STOP.

- Not OK – There is a problem with the fuel injection pump. Contact the Perkins Technical Support Centre in order to check if the software version is correct. Also check that there have been no software updates. If the problem still exists contact the Perkins Technical Support Centre in order to change the fuel injection pump. The warranty of the fuel injection pump will be affected if the pump is replaced without prior consultation. Replace the fuel injection pump.

Repair: Refer to Disassembly and Assembly, “Fuel Injection Pump Remove and Install”.

STOP.

Test Step 11. Check the Voltage Load Protection Module (VLPM)

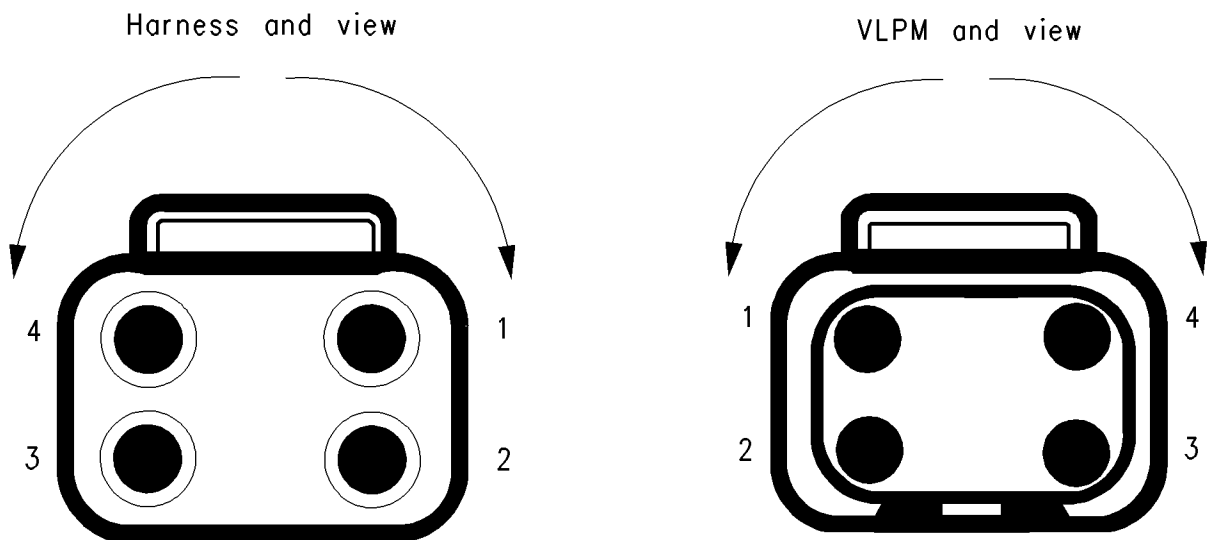

Illustration 106

g00908544

Voltage load protection module (VLPM) connections

Use this test in order to verify that the Voltage Load Protection Module (VLPM) has the correct resistance. Also use this procedure if there is a problem with a blown fuse. A faulty Voltage Load Protection Module (VLPM) may be the cause of the problem.

- A. Measure the resistance between pin 1 and pin 2 of the Voltage Load Protection Module (VLPM).
- B. Measure the resistance between pin 3 and pin 4 of the Voltage Load Protection Module (VLPM).

Expected Result:

The resistance should be less than 1 ohm between pin 1 and pin 2.

The resistance should be less than 1 ohm between pin 3 and pin 4.

The resistance should be greater than 1 ohm between pin 2 and pin 3.

Note: The resistance between pin 2 and pin 3 may differ. The resistance may be less than 1 ohm. This is OK.

Results:

- OK – STOP.
- Not OK – There is a problem with the voltage load protection module.

Repair: Replace the voltage load protection module.

The voltage load protection module should also be replaced when the fuel injection pump is replaced.

STOP.

i01798195

Indicator Lamp Circuit - Test

System Operation Description:

Use this procedure under the following circumstances:

- The lamps are not receiving battery voltage.
- The lamps are not operating properly.

Also, use this procedure if another procedure has directed you here.

The following diagnostic lamps are available with the 12 V system:

- Set speed lamp
- Warning lamp
- Engine shutdown lamp

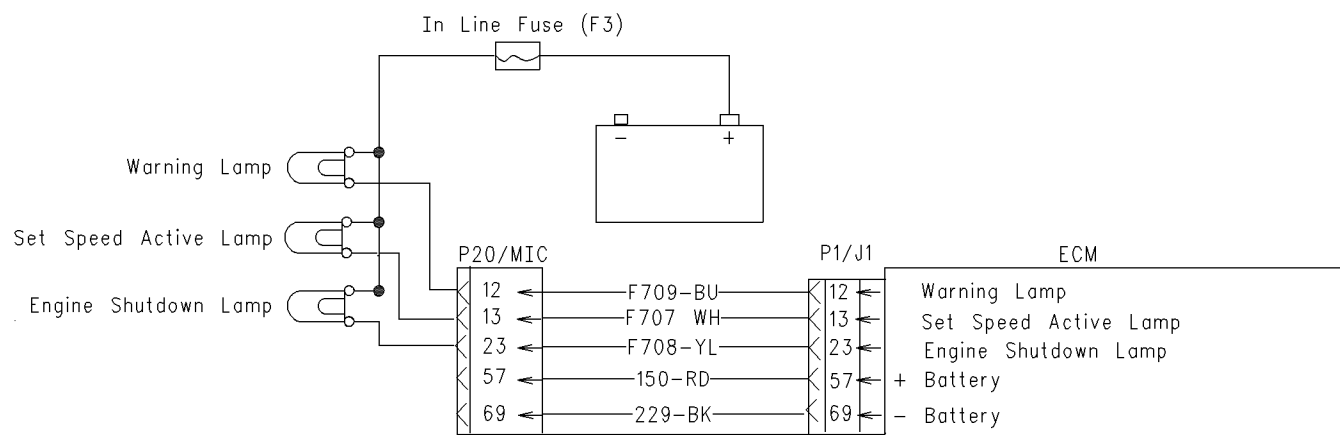

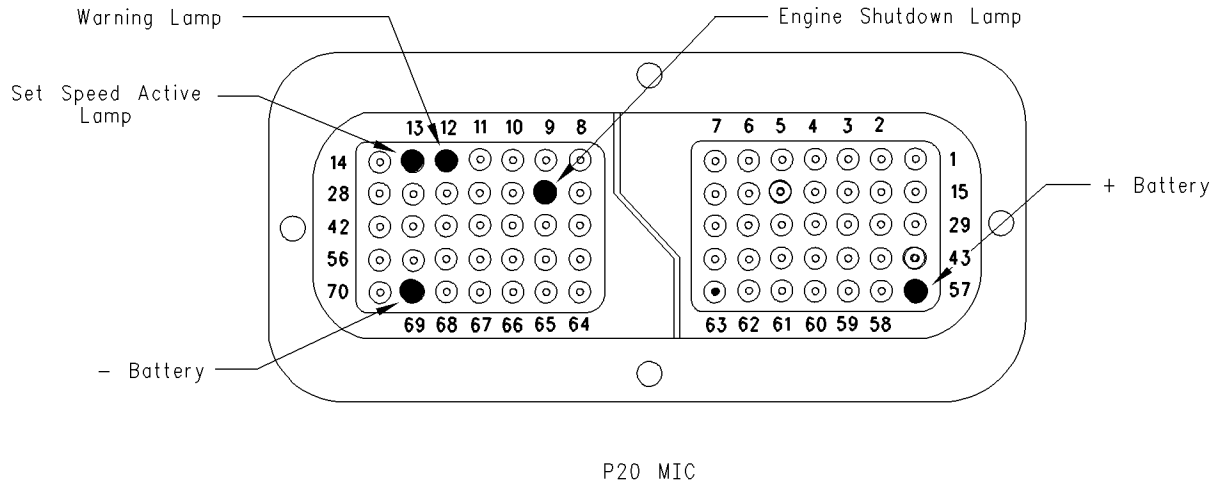

Illustration 108
 Machine Interface Connector (MIC) pin locations for the indicator lamps.

g00954724

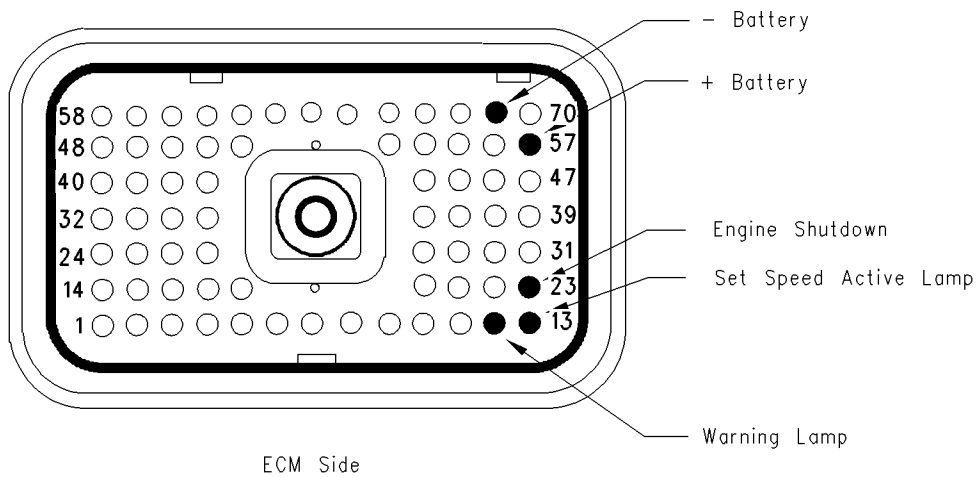

Illustration 109
 ECM pin locations for the indicator lamps

g00913254

Test Step 1. Inspect Electrical Connectors and Wiring

- A. Turn the keyswitch to the OFF position.
- B. Thoroughly inspect J1/P1 ECM connector, and the J20/P20 MIC. Refer to Troubleshooting, "Electrical Connectors - Inspect" for details.
- C. Perform a 45 N (10 lb) pull test on each of the wires in the customer connector and the ECM connector that are associated with the diagnostic lamp. Refer to illustration 109.
- D. Check the J1/P1 ECM connector (Allen head screw) for the proper torque of 2.25 ± 0.25 N·m (20 ± 2 lb in).

Check the J20/P20 Machine Interface Connector (MIC) for the proper torque of 6.0 N·m (55 lb in).

- E. Check the harness and wiring for abrasions and for pinch points from the battery to the ECM.

Results:

- OK – Proceed to Test Step 2.
- Not OK

Repair: Repair the connectors or wiring and/or replace the connectors or wiring. Ensure that all of the seals are properly in place and ensure that the connectors are completely coupled.

Verify that the repair eliminates the problem.

STOP.

Test Step 2. Inspect the Lamp, the Fuse, and the Power Supply

- A. Disconnect the lamp from the wiring harness. Inspect the lamp in order to determine if the lamp has failed.
- B. Measure the resistance across the two terminals of the lamp. If the resistance is more than 2000 ohms, the bulb has failed.
- C. Check the battery by connecting a test lamp across the terminal of the battery.

Expected Result:

The lamp has less than 2000 ohms and the power supply is OK.

Results:

- OK – The lamp appears to be operating correctly at this time. Proceed to Test Step 3.

- Not OK

Repair: Replace the suspect component or repair the suspect component. Verify that the repairs have eliminated the problem.

STOP.

Test Step 3. Inspect the Input to the Lamp at the ECM connector

- A. Turn the keyswitch to the ON position.
- B. Measure the voltage at the lamp socket.

Expected Result:

The voltage should be between 12.0 VDC and 24.0 VDC.

Results:

- OK – The voltage is between 12.0 VDC and 24.0 VDC.

Repair: Replace the bulb.

Verify that the repair eliminates the problem.

Proceed to Test Step 4.

- Not OK – The voltage is not in the range that is expected. Proceed to Test Step 5.

Test Step 4. Test the Individual Lamp Circuits

- A. Disconnect ECM Connector J1/P1.
- B. Insert a 70-Pin Breakout T between ECM Connector J1 and ECM Connector P1.
- C. Fabricate a jumper wire 100 mm (4 inch) long. Crimp a Deutsch pin to both ends of the wire.
- D. Insert one end of the jumper wire into the socket for the driver for the suspect lamp.
- E. Insert the other end of the jumper wire into the socket for -battery.
- F. Turn the keyswitch to the ON position and observe the lamp.

Expected Result:

The diagnostic lamp turns on while the jumper is connected to both sockets. Also, the diagnostic lamp turns off when the jumper is removed from one of the sockets.

Results:

- OK – The circuit for the diagnostic lamp is functioning properly. Proceed to Test Step 5.
- Not OK – The lamp did not turn on. The lamp circuit is not functioning properly. There is a problem in the wiring between the lamp and the ECM.

Repair: Repair the lamp circuit.

Verify that the repair eliminated the problem.

STOP.

Test Step 5. Check the Voltage at the ECM.

- A. Disconnect ECM Connector J1/P1.
- B. Insert a 70-Pin Breakout T between ECM Connector J1 and ECM Connector P1.
- C. Connect a voltage test lamp between J1:57 + battery and J1:69 Neg. battery.
- D. Connect a voltage test lamp to J1:57 + battery and J1:23 engine shutdown lamp.

Expected Result:

The lamp should illuminate.

Results:

- OK – The ECM is operating correctly. There is a problem in the wiring or the lamp. Repair the wiring or the lamp, as required. Verify that the repair eliminates the problem. STOP.
- Not OK – Temporarily connect a test ECM. The test ECM must be programmed with the same parameters as the suspect ECM. Check the operation of the diagnostic lamp when the test ECM is installed. If the problem is resolved with the test ECM, then reconnect the suspect ECM. If the problem returns with the suspect ECM, then replace the suspect ECM. STOP.

- Check if the switch can be switched to ground.
- Check if the mode selector switch operates correctly.

Also, use this procedure if another procedure has directed you here.

The mode selector switch provides the operator with the ability to select a maximum of eight different modes of operation. Different modes of operation can be used in a particular situation by giving the operator a means to select the most efficient method of completing the required work. The following mode selections are available:

- Economy Mode
- Machine Mode
- Power Take-off Mode

Three digital switch inputs can be used in order to select the most efficient mode. With three switches, a maximum of eight modes can be applied by use of a multiple position switch. With two switches, four modes can be selected. With one switch, two modes can be selected. Each mode has a single fuel limit map, a rated speed, and a matched fuel delivery. Each mode also has specific droop value for throttle 1 and throttle 2.

i01798876

Mode Selection Circuit - Test

System Operation Description:

Use this procedure under the following circumstances:

Test Step 1. Inspect Electrical Connectors and Wiring

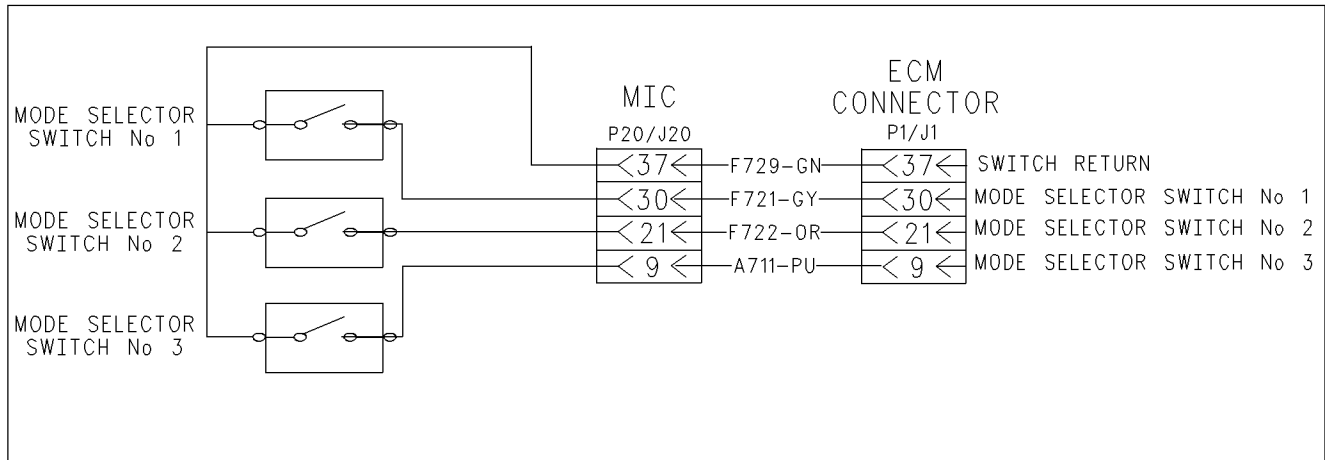

Illustration 110

g00955196

Schematic for the mode selector switch

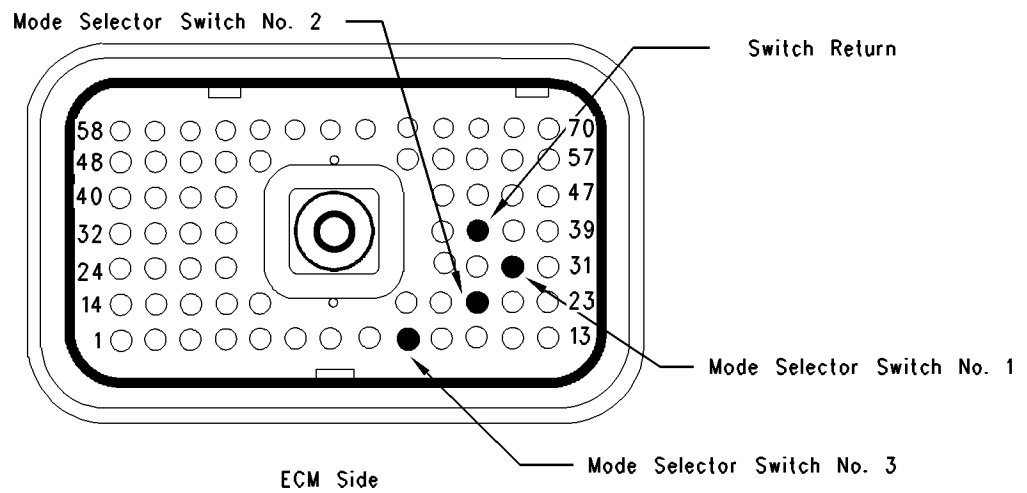

Illustration 111

g00878231

ECM pin locations for the mode selector switch

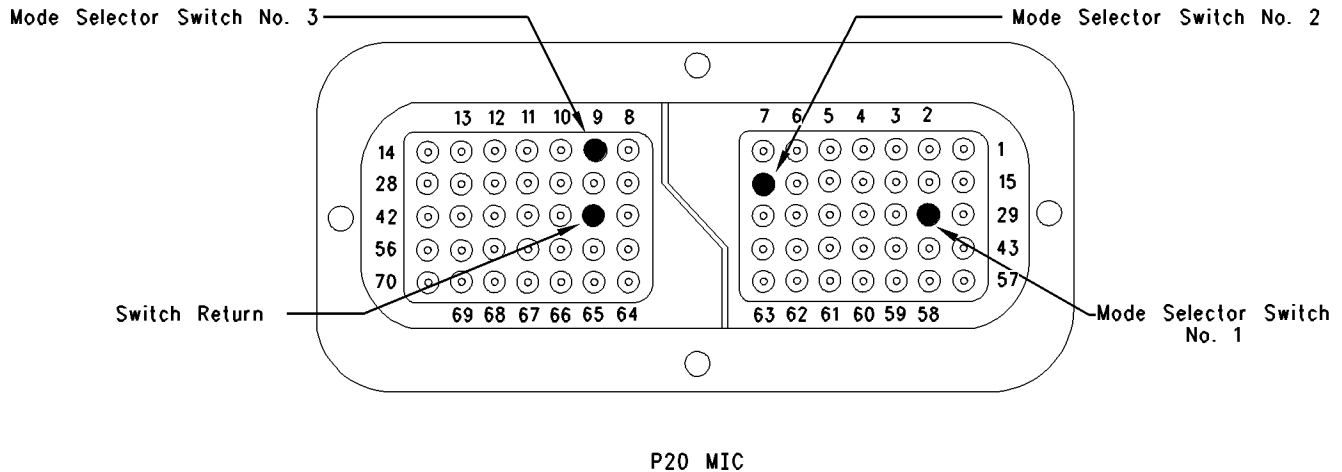

Illustration 112

g00955199

MIC pin locations for the mode selector switch

- A. Turn the keyswitch OFF.
- B. Thoroughly inspect J1/P1 ECM connector, and the J20/P20 MIC. Refer to Troubleshooting, “Electrical Connectors - Inspect” for details.
- C. Perform a 45 N (10 lb) pull test on each of the wires in the P1/J1 ECM connector and the P20/J20 MIC that are associated with the Mode Selector Switch: Refer to illustration 111 and 112.
- D. Check the J1/P1 ECM connector (Allen head screw) for the proper torque of 2.25 ± 0.25 N·m (20 ± 2 lb in).

Check the J20/P20 Machine Interface Connector (MIC) for the proper torque of 6.0 N·m (55 lb in).

- E. Check the harness and wiring for abrasions and for pinch points from the battery to the ECM.

Results:

- OK – Proceed to Test Step 2.
- Not OK

Repair: Repair the connectors or wiring and/or replace the connectors or wiring. Ensure that all of the seals are properly in place and ensure that the connectors are completely coupled.

Verify that the repair eliminates the problem.

STOP.

- – If the problem has not been eliminated proceed to Test Step 2.

Test Step 2. Check the Status of the Mode Selector Switch

- A. Turn the keyswitch to the OFF position.
- B. Connect the electronic service tool to the diagnostic connector.
- C. Turn the keyswitch to the ON position.
- D. Monitor the status screen on the electronic service tool. Cycle the mode switch to the ON position and to the OFF position.

Expected Result:

The switch status should change as you cycle the mode switches. When the switch is in the OFF position the switch has an open condition. When the switch is in the ON position the switch has a closed condition.

Results:

- OK

Repair: Verify that the status of the switch changes as the switch is cycled.

STOP.

- Not OK – There is a problem with the circuit for the mode selector switch. Proceed to Test Step 3.

Test Step 3. Insert a Jumper at the Suspect Mode Switch

Illustration 113

g00955199

- Turn the keyswitch to the OFF position. Disconnect the suspect mode switch.
- Perform the following procedure to test the circuit of Mode Selector Switch No. 1. Insert the jumper wire between P20:30 Switch Input 9 and P20:37 Switch Return.
- Perform the following procedure to test the circuit of Mode Selector Switch No. 2. Insert a jumper wire between P20:21 Switch Input 10 and P20:37 Switch Return.
- Perform the following procedure to test the circuit of Mode Selector Switch No. 3. Insert a jumper wire between P20:9 Switch Input 11 and P20:37 Switch Return.

- E. Turn the keyswitch to the ON position. Monitor the status screen on the electronic service tool. Slowly connect and disconnect the jumper wire.

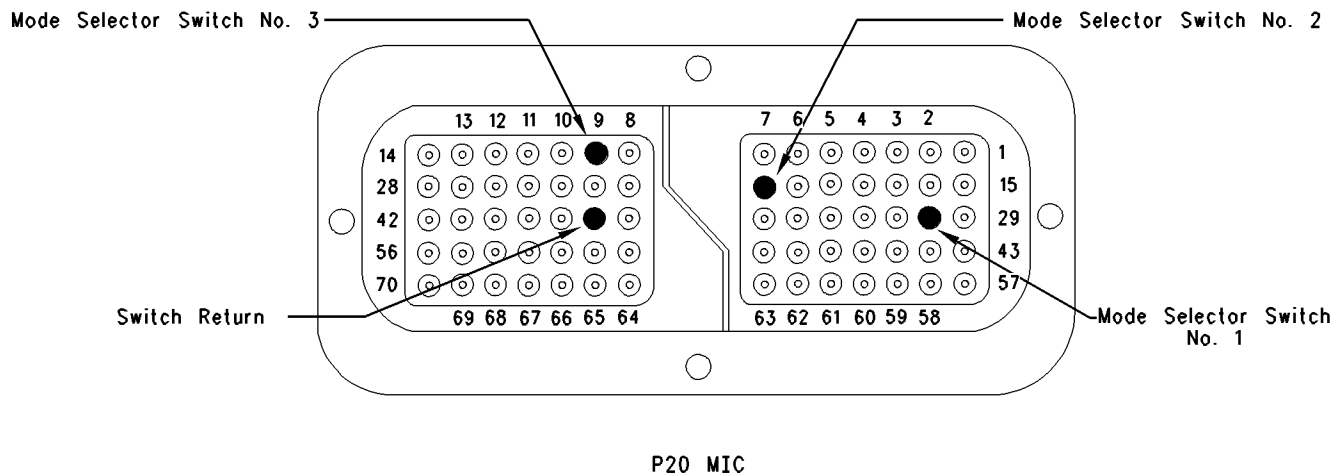
Expected Result:

When the jumper wire is disconnected the switch should be in the OPEN position. When the jumper wire is connected the switch should be in the CLOSED position.

Results:

- OK

Repair: Verify that the jumper wire has been removed. The suspect mode selector switch is faulty. Replace the switch and verify that the repair has eliminated the problem.

STOP.

- Not OK – Proceed to Test Step 4.

Test Step 4. Measure the Resistance at the P20/J20 MIC

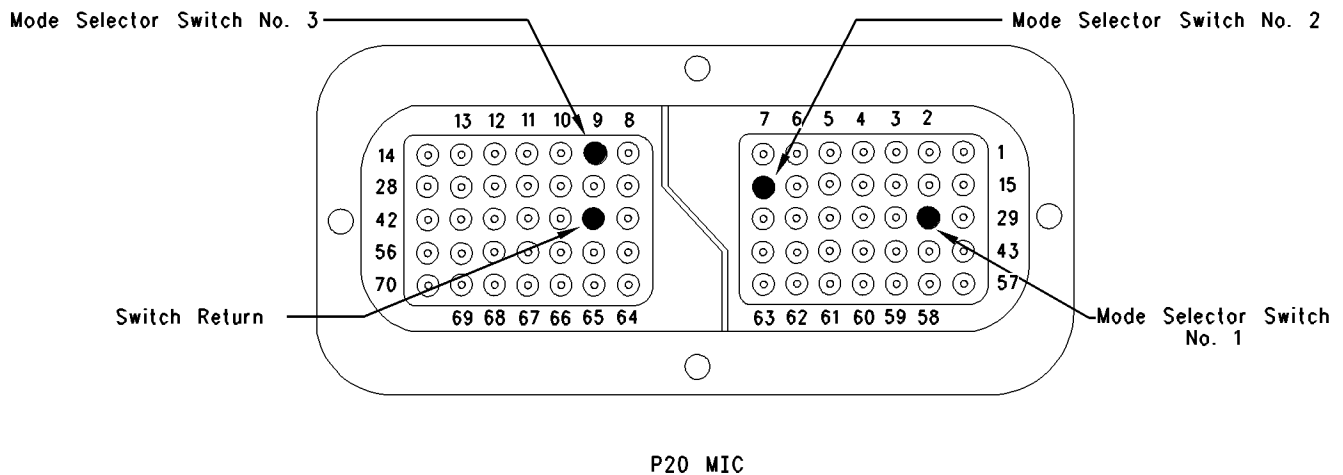

Illustration 114

g00955199

- A. Turn the keyswitch to the OFF position.
- B. Reconnect the suspect switch.
- C. Disconnect the P20 connector from the J20 MIC.
- D. Measure the resistance between P20:37 switch return and the following MIC pins:
 - P20:30 Switch No. 1

- P20:21 Switch No. 2
- P20:9 Switch No. 3

Expected Result:

The switch measures less than 10 ohms in the ON position.

The switch measures more than 2000 ohms in the OFF position.

Results:

- OK – Proceed to Test Step 5.
- Not OK – The problem is in the wires between the switch and the MIC.

Repair: Repair the connector or replace the connector. Verify that the repair has eliminated the problem.

Repeat Test Step 3 if the problem has not been eliminated.

Test Step 5. Measure the Resistance of the Wire Harness at the ECM

Illustration 115

g00878231

- Turn the keyswitch to the OFF position.
- Disconnect the P1 connector from the ECM connector.
- Measure the resistance between P1:37 switch return and the following ECM pins:
 - P1:30 Switch No. 1

- P1:21 Switch No. 2
- P1:9 Switch No. 3

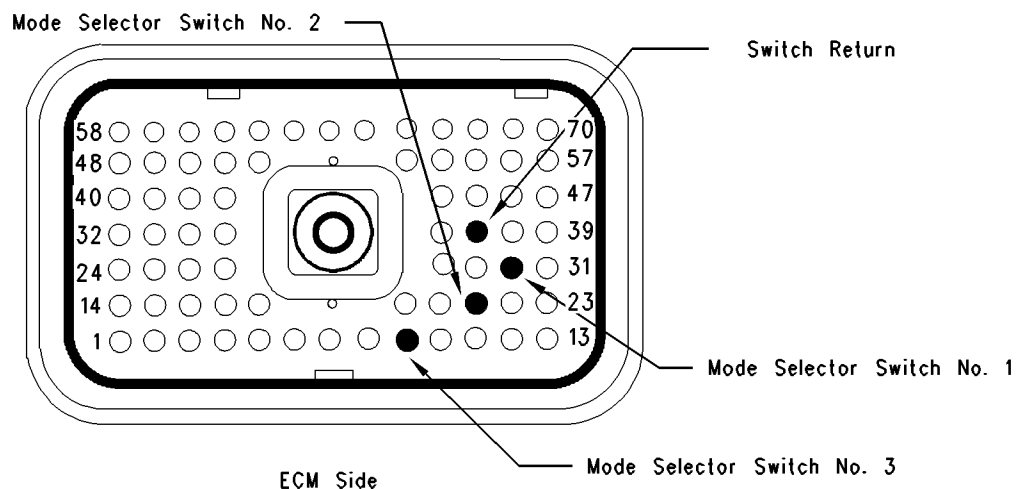
D. Cycle the switch to the OFF position and to the ON position.

Expected Result:

The switch measures less than 10 ohms in the ON position.

The switch measures more than 2000 ohms in the OFF position.

Results:

- OK – There is not a problem with the wire or the wire harness. Proceed to Test Step 6.
- Not OK – The problem is in the wire harness between the MIC and the ECM connector.

Repair: Repair the connector or replace the connector. Verify that the repair has eliminated the problem.

Proceed to Test Step 6 if the problem has not been eliminated.

Test Step 6. Test the ECM

- A. Turn the keyswitch to the OFF position.
- B. Disconnect the P1 connector from the P1/J1 ECM connector. Connect a 70 pin Breakout T between the ECM connector J1 and ECM connector P1.
- C. Measure the resistance between P1:37 switch return and the following MIC pins:
- P1:30 Switch No. 1
 - P1:21 Switch No. 2
 - P1:9 Switch No. 3
- D. Insert a jumper wire between the suspect switch socket in the 70 pin Breakout T and the socket 37 of the Breakout T.
- E. Turn the keyswitch to the ON position. Monitor the status screen on the electronic service tool. Slowly connect and disconnect the jumper wire from the 70 pin Breakout T.

Expected Result:

With the switch in the OFF position, the switch will have an open condition.

With the switch in the ON position, the switch will have a closed condition.

Results:

- OK – The ECM is operating correctly. STOP.
- Not OK

Repair: If the problem has not been eliminated temporarily connect a test ECM. Remove all jumpers and replace all connectors. The test ECM should be programmed with the correct software. All parameters should be set to the same value of the suspect ECM.

If the problem is eliminated with the test ECM, reconnect the suspect ECM. If the problem returns with the suspect ECM, replace the suspect ECM.

Verify that the repair has eliminated the problem.

STOP.

i01798877

Set Speed Circuit - Test

System Operation Description:

Use this procedure under the following circumstances:

- Verify that the set speed switch receives the proper supply voltage.
- Check that the set speed switches operate correctly.

Also, use this procedure if another procedure has directed you here.

The set speed switch provides the operator with the ability to select the desired engine speed. Engine speed will decrease with increasing load. The set speed control can be used to control the engine speed. Also for certain engine applications, the set speed control can be used to control the vehicle speed.

The 1104 and 1106 engines have the following options of set speed control:

- Single speed
- Dual Speed
- No speed (no set speed control)

The set speed switches are listed below:

- P1:28 Set Speed Control ON or OFF
- P1:11 Set Speed Continue or Accelerate
- P1:19 Set Speed 1 or Set Speed 2
- P1:20 Set Speed Set or Decelerate
- P1:29 Clutch or Brake Automatic Disengage

Warning lamps are used to indicate the status of the set speed control.

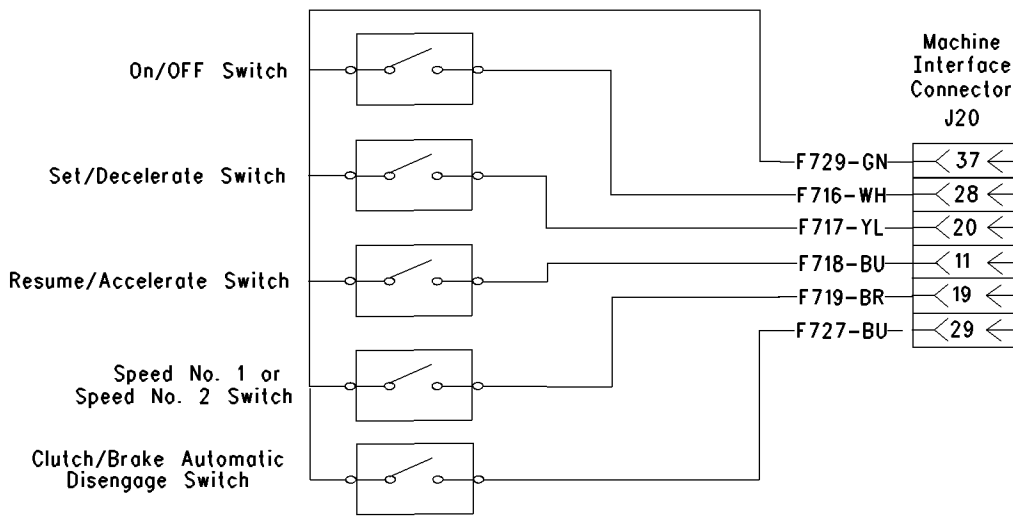

Illustration 116

g00907553

Schematic for the set speed switch

Test Step 1. Inspect Electrical Connectors and Wiring

- Turn the keyswitch to the OFF position.
- Thoroughly inspect ECM connector J1/P1, machine interface connector J20/P20, and the battery connections. Refer to Troubleshooting, "Electrical Connectors - Inspect" for details.
- Check the harness and wiring for corrosion, abrasion, and pinch points from the throttle switch to the ECM.

Expected Result:

All connectors, pins, and sockets should be completely inserted and coupled. The harness and wiring should be free of corrosion, abrasion, and pinch points.

Results:

- OK – Proceed to Test Step 2.
- Not OK

Repair: Repair the circuit.

Verify that the repair eliminates the problem.

STOP.

Test Step 2. Check “Set Speed Switch” on the Electronic Service Tool

- A. Turn the keyswitch to the OFF position.
- B. Connect the electronic service tool to the diagnostic connector.
- C. Turn the keyswitch to the ON position.
- D. Observe the status of the set speed switch on the electronic service tool while you operate the set speed switch from the speed 1 position to the speed 2 position.
- E. Observe the status of the set speed switch on the electronic service tool while you operate the set speed switch from the ON position to the OFF position.
- F. Observe the status of the set speed switch while you operate the set speed/decelerate switch from the OFF position to the ON position.
- G. Observe the status of the set speed control resume or accelerate switch while you operate the switch from the OFF position to the ON position.

Expected Result:

Result 1 the electronic service tool will show that the speed 1 status is selected with the set speed switch in the OFF position.

The electronic service tool will show that the speed 2 status is selected with the set speed switch in the ON position.

Note: If the engine application has two engine speed controls ensure that speed 1 is selected.

Result 2 The electronic service tool will show that the set speed control switch is in the “OPEN” condition when the set speed control switch is in the OFF position.

The electronic service tool will show that the set speed switch is in the “CLOSED” position when the set speed switch is in the ON position.

Note: The set speed control lamp should be OFF when the set speed control switch is in the OFF position. The set speed control lamp should be flashing when the set speed control switch is in the ON position.

Result 3 When the set speed switch is in the OFF position the set speed/decelerate switch should be in the OPEN position.

When the set speed/decelerate switch is in the ON position the set speed/decelerate switch should be in the CLOSED position.

Result 4 When the set speed control resume or accelerate switch is in the OFF position the display screen should show an OPEN condition.

When the set speed control resume or accelerate switch is in the ON position the display screen should show a CLOSED condition.

Note: The set speed control lamp 1 should change from flashing to ON when the set speed resume or accelerate switch is CLOSED.

Results:

- OK – The set speed control switches operate correctly. STOP.
- Not OK – Proceed to Test Step 3.

Test Step 3. Check the Status of the Automatic Set Speed Disengage Switch

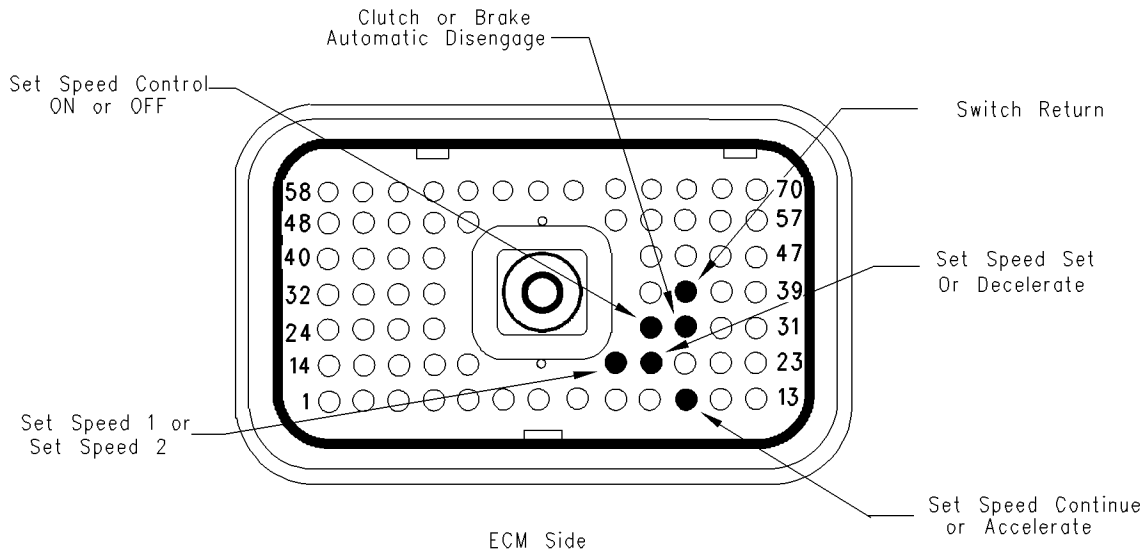

Illustration 117

g00907849

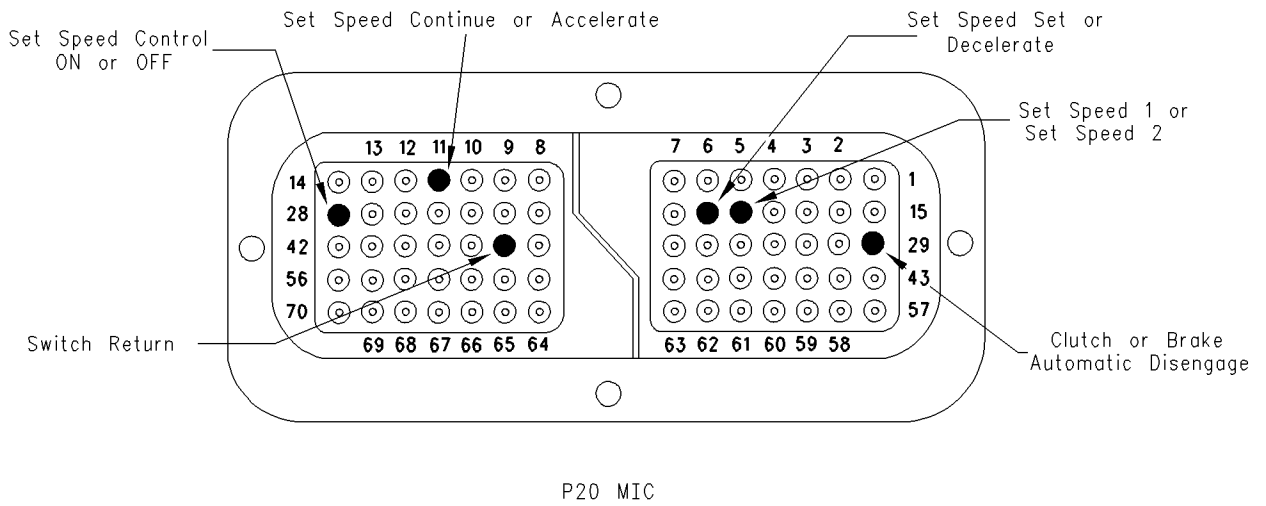

Illustration 118

g00955250

A. Disconnect the P20/J20 machine interface connector.

B. Insert a 70 pin Breakout T between the P20 and J20.

C. Measure the resistance between the following pin locations:

- P20:29
- P20:37

D. Use the electronic service tool to observe the voltage while the Automatic Set Speed Disengage Switch is operated OFF and ON.

Expected Result:

The electronic service tool will show that the status of the automatic set speed disengage switch is in the “ENGAGED” position. The voltage should be between 0 V and 0.8 V.

The electronic service tool will show that the status of the automatic set speed disengage switch is in the “DISENGAGED” position. The voltage should be between 12.3 V and 12.9 V.

Results:

- OK – The set speed disengage switch operates correctly. STOP.
- Not OK – Proceed to Test Step 4.

Test Step 4. Check the Speed Control Switch

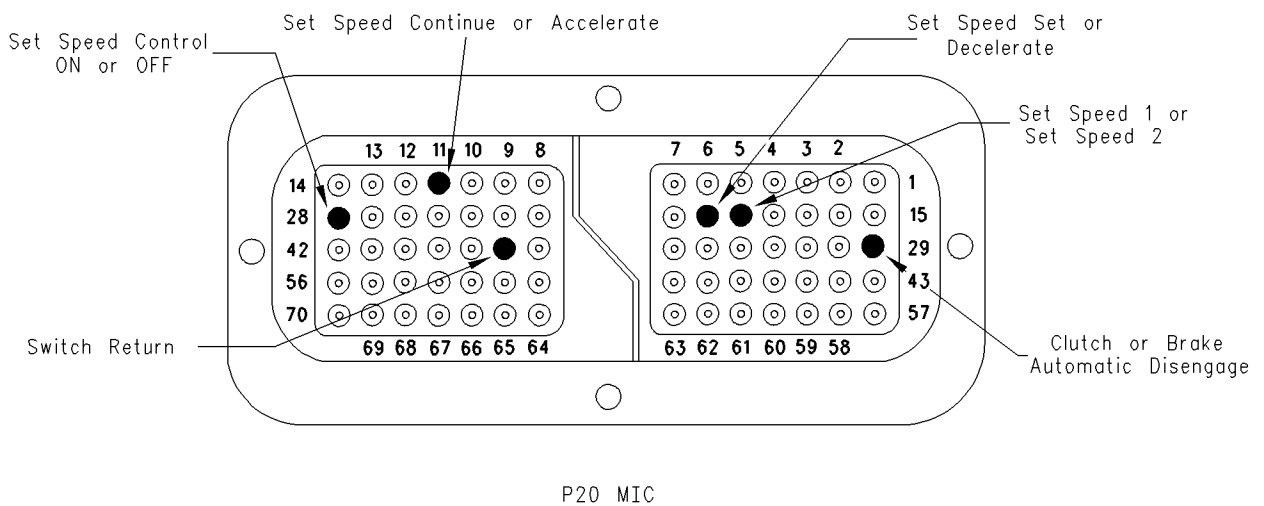

- A. Turn the keyswitch to the OFF position.
- B. Remove the two wires from the P20:11 set speed control continue or accelerate switch. Use a suitable jumper in order to join the two wires together.
- C. Turn the keyswitch to the ON position.
- D. Monitor the status screen on the electronic service tool. Slowly connect and disconnect the jumper from the P20:11.
- E. Repeat this procedure for each of the following “machine interface connections”:
 - P20:19 Set Speed Control 1 or Speed 2
 - P20:20 Set Speed Control Speed or Decelerate
 - P20:28 Set Speed Control ON or OFF
 - P20:29 Set Speed Control Kickout Switch
 - P20:37 Switch Return

Expected Result:

When the jumper wire is connected the status of the set speed switch should be “CLOSED”.

When the jumper wire is disconnected the status of the set speed switch should be “OPEN”.

Results:

- OK – The switch is faulty.

Repair: Replace the switch and verify that the repair has eliminated the problem.

STOP.

- Not OK – There is a problem with the wiring harness between the set speed control switch and the engine ECM. Proceed to Test Step 5.

Test Step 5. Measure the Resistance of the Cables at the Machine Interface Connector (MIC)

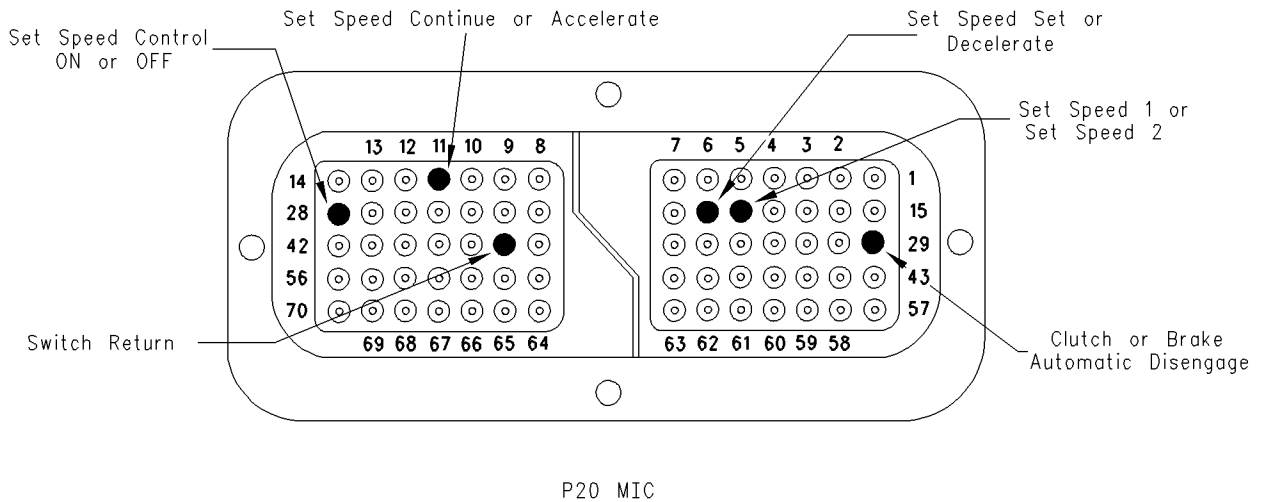

Illustration 120

g00955250

- A. Turn the keyswitch to the OFF position.
- B. Connect the cables to the suspect switch.
- C. Disconnect the P20:11 set speed control resume or accelerate switch from the P20/J20 Machine Interface Connector.
- D. Measure the resistance from P20:11 set speed control resume or accelerate switch to P20:37 Switch Return.
- E. Perform the same procedure with the following MIC pin connections:
 - P20:19 Set speed control speed 1 or speed 2
 - P20:20 Set speed control set or decelerate
 - P20:28 Set speed control ON or OFF
 - P20:29 Set speed control clutch or brake disengage

Expected Result:

The measured resistance should be less than 10 ohms with the switch ON.

The measured resistance should be more than 2000 ohms with the switch OFF.

Results:

- OK – Proceed to Test Step 6.
- Not OK – There is a problem with the wires between the suspect switch and the P20 connector.

Repair: Repair the wires or replace the wires. Verify that the repair has eliminated the problem.

STOP.

Test Step 6. Measure the Resistance of the Cables at the ECM

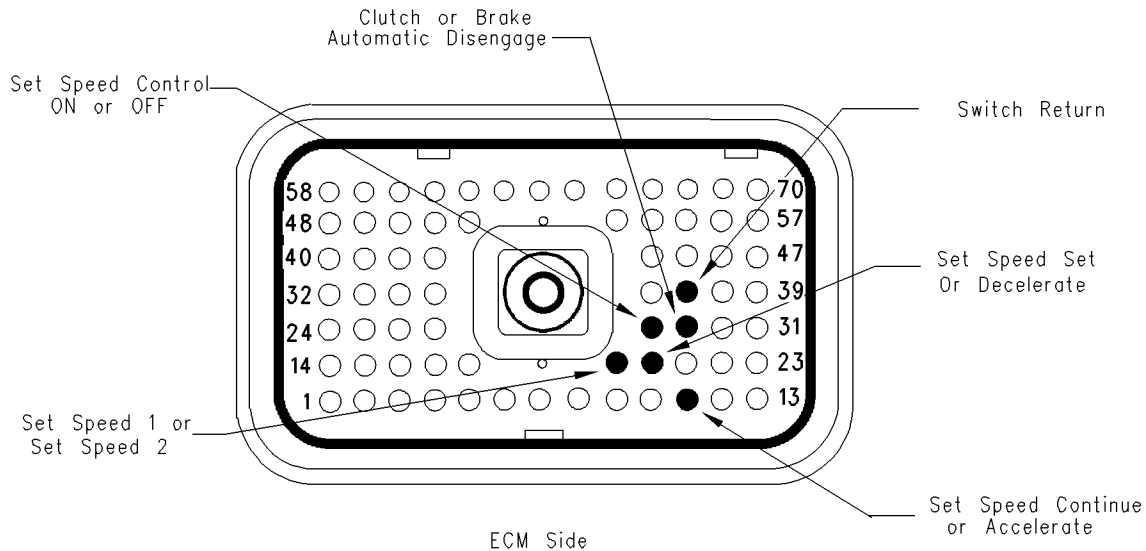

Illustration 121

g00907849

- A. Turn the keyswitch to the OFF position.
- B. Reconnect the P20 MIC.
- C. Disconnect P1 ECM connector from the ECM.
- D. Measure the resistance between P1:11 Set speed control continue or accelerate and P1:37 Switch return. First measure the resistance with the switch in the OFF position and then measure the switch in the ON position.
- E. Measure the resistance between P1:37 and each of ECM pin locations:
 - P1:19 Set speed control speed 1 or speed 2
 - P1:20 Set speed control set or decelerate
 - P1:28 Set speed control ON or OFF
 - P1:29 Set speed control clutch or brake disengage

Expected Result:

The measured voltage should be less than 10 ohms with the switch in the ON position.

The measured voltage should be more than 2000 ohms with the switch in the OFF position.

Results:

- OK – Proceed to Test Step 7.
- Not OK – There is a problem in the wires between the MIC and the ECM connector.

Repair: Repair the wires or replace the wires.

Verify that the repair has eliminated the problem. If the problem has not been eliminated repeat Troubleshooting, "Electrical Connectors - Inspect".

STOP.

Test Step 7. Test the Engine ECM

- A. Turn the keyswitch to the OFF position.
- B. Insert a 70 pin Breakout T between the P1 connector and P2 connector.
- C. Insert one end of a jumper wire into the socket for the suspect switch. Insert the other end of the jumper wire into P1:37 switch return.
- D. Turn the keyswitch to the ON position and monitor the status screen on the electronic service tool. Slowly connect and disconnect the jumper wire from the socket of pin 37 of the Breakout T.

E. Repeat this procedure for each of the following ECM pin connections:

- P1:11 Set speed control continue or accelerate
- P1:19 Set speed control speed 1 or speed 2
- P1:20 Set speed control or decelerate
- P1:28 Set speed control ON or OFF
- P1:29 Set speed control clutch or brake disengage

Expected Result:

The status screen should display an OPEN condition with the switch in the OFF position.

The status screen should display a CLOSED condition with the switch in the ON position.

Results:

- OK – The ECM is working correctly. STOP.
- Not OK – The ECM is not working properly.

Repair: Temporarily connect a test ECM.

The test ECM should be programmed with the correct software. All parameters should be set to the same values as the suspect ECM.

If the problem is eliminated with the test ECM, reconnect the suspect ECM.

If the problem returns with the suspect ECM, then the suspect ECM is faulty.

Replace the suspect ECM.

Verify that the repair has eliminated the problem.

STOP.

Also, use this procedure if another procedure has directed you here.

The throttle switch provides the operator with the ability to select the desired engine speed. Engine speed will decrease with increasing load. The throttle switch is a rotary switch with ten positions.

The throttle switch is connected to the four throttle inputs of the Electronic Control Module (ECM). Each position generates a specific on/off pattern on the throttle inputs. A diagnostic code is generated if a pattern that does not correspond with any of the switch positions is detected.

Once a diagnostic code is generated, the ECM ignores the throttle input signals and desired engine speed is set to the last valid pattern that was recognized by the ECM. Desired engine speed is set to low idle while the engine is not running.

Voltage at the throttle inputs to the ECM should be 11.5 ± 0.5 VDC when the throttle inputs are open. The voltage should be less than 0.5 VDC when the throttle inputs are closed.

i01798878

Throttle Switch Circuit - Test

System Operation Description:

Use this procedure under the following circumstances:

- Throttle switch inputs can be switched to ground.
- Verification of the throttle switch

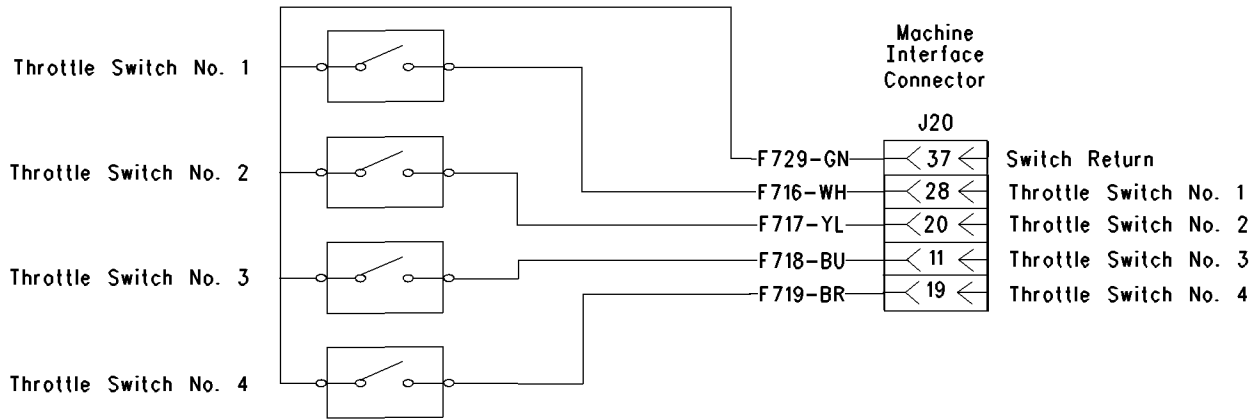

Illustration 122

g00905920

Table 13

| Correlation Between Throttle Switch Position and Status of the Throttle Inputs | | | | |
|--|---------------------------------------|---------------------|---------------------|---------------------|
| Throttle Switch Position | Status on the Electronic Service Tool | | | |
| | “Throttle Input #1” | “Throttle Input #2” | “Throttle Input #3” | “Throttle Input #4” |
| 1 | On | Off | Off | Off |
| 2 | On | On | Off | Off |
| 3 | Off | On | Off | Off |
| 4 | Off | On | On | Off |
| 5 | On | On | On | Off |
| 6 | On | Off | On | Off |
| 7 | Off | Off | On | Off |
| 8 | Off | Off | On | On |
| 9 | On | Off | On | On |
| 10 | On | On | On | On |

Test Step 1. Inspect Electrical Connectors and Wiring

- A. Turn the keyswitch to the OFF position.
- B. Thoroughly inspect ECM connector J1/P1, machine interface connector J20/P20, and the battery connections. Refer to Troubleshooting, “Electrical Connectors - Inspect” for details.

- C. Check the harness and wiring for corrosion, abrasion, and pinch points from the throttle switch to the ECM.

Expected Result:

All connectors, pins, and sockets should be completely inserted and coupled. The harness and wiring should be free of corrosion, abrasion, and pinch points.

Results:

- OK – Proceed to Test Step 2.
- Not OK

Repair: Repair the circuit.

Verify that the repair eliminates the problem.

STOP.

Test Step 2. Check “Throttle Switch Position” on the Electronic Service Tool

- Turn the keyswitch to the OFF position.
- Connect the electronic service tool to the diagnostic connector.
- Turn the keyswitch to the ON position.
- Observe the status of the throttle switch and the throttle inputs on the electronic service tool while you operate the throttle switch in each position.

Expected Result:

The status on the electronic service tool should correspond with the information in Table 13.

Results:

- OK – The throttle switch is functioning properly at this time.

Repair: Refer to Troubleshooting, “Electrical Connectors - Inspect” if the problem is intermittent.

STOP.

- Not OK – Record the suspect input. Proceed to Test Step 3.

Test Step 3. Jumper the Switch Input at the Suspect Throttle Position Switch

- Turn the keyswitch to the OFF position.
- Observe the status of the suspect throttle input on the electronic service tool.
- Use a suitable piece of wire to short P/20:37 Switch Return to the terminal for the suspect throttle input.
- Observe the status of the suspect throttle input on the electronic service tool.
- Remove the wire short.

Expected Result:

The status of the suspect throttle input should be “OFF” when the jumper wire is disconnected. The status should be “ON” when the jumper wire is connected.

Results:

- OK – The harness and the ECM are OK.

Repair: Replace the throttle switch.

Verify that the repair eliminates the problem.

STOP.

- Not OK – Proceed to Test Step 4.

Test Step 4. Check for Shorts in the Harness

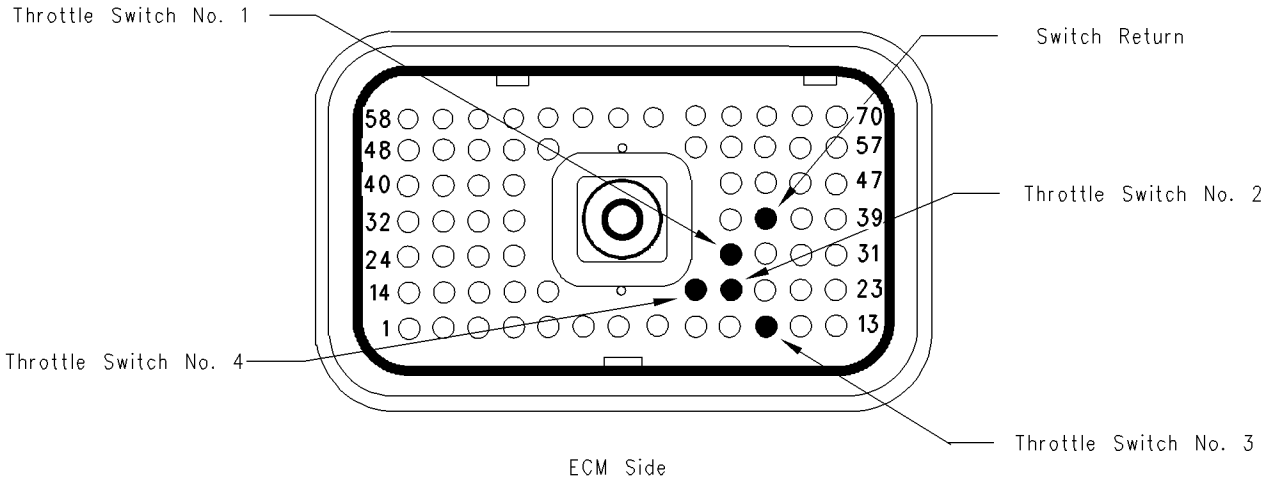

Illustration 123

g00874926

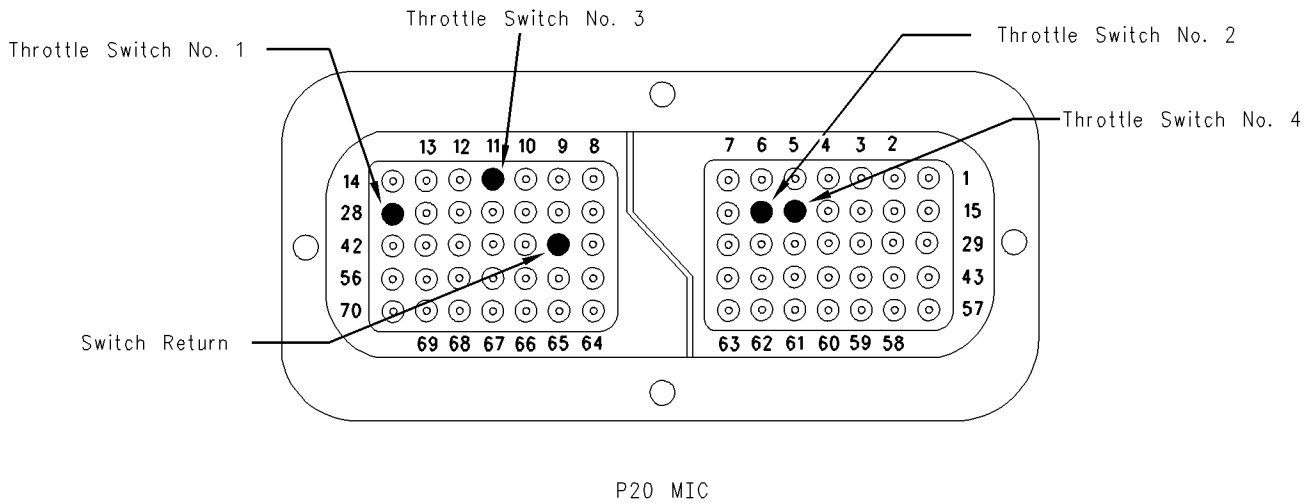

Illustration 124

g00977350

A. Turn the keyswitch to the OFF position.

B. Disconnect J1/P1 ECM connector from the J20/P20 MIC.

C. Measure the resistance between the P1:37 switch return and the terminal for the suspect throttle input.

D. Measure the resistance between the terminal for the suspect throttle input and the remaining terminals at the J20/P20 MIC:

- P20:28 Throttle Switch No. 1
- P20:20 Throttle Switch No. 2
- P20:11 Throttle Switch No. 3
- P20:19 Throttle Switch No. 4

Expected Result:

Resistance should be greater than 2,000 ohms for each reading.

Results:

- OK – Proceed to Test Step 5.
- Not OK – There is a short in the harness between the ECM and the throttle switch.

Repair: Repair the circuit.

Verify that the repair eliminates the problem.

STOP.

Test Step 5. Check Resistance through the Harness

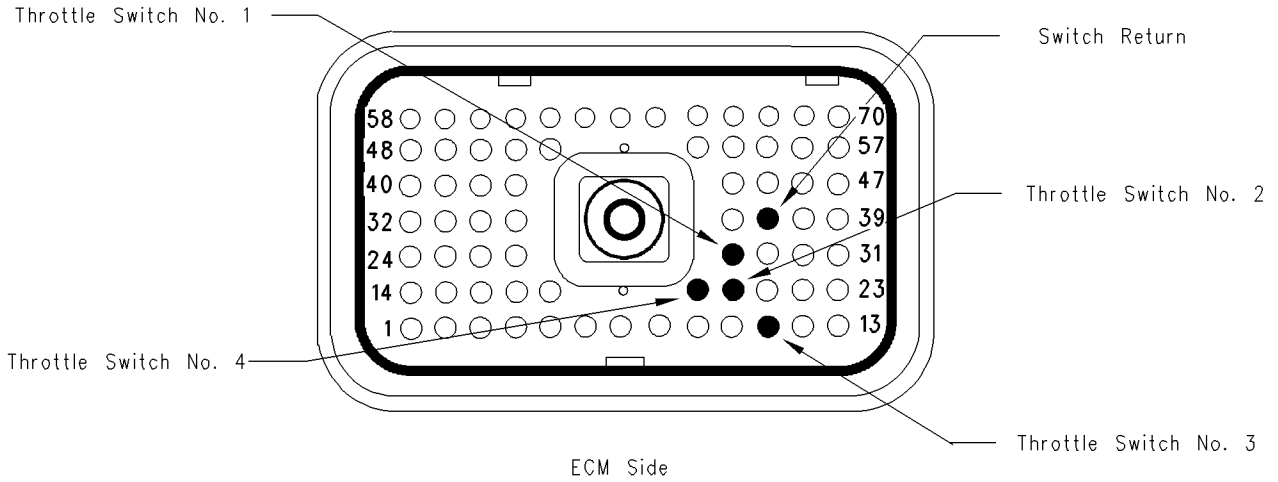

Illustration 125

g00874926

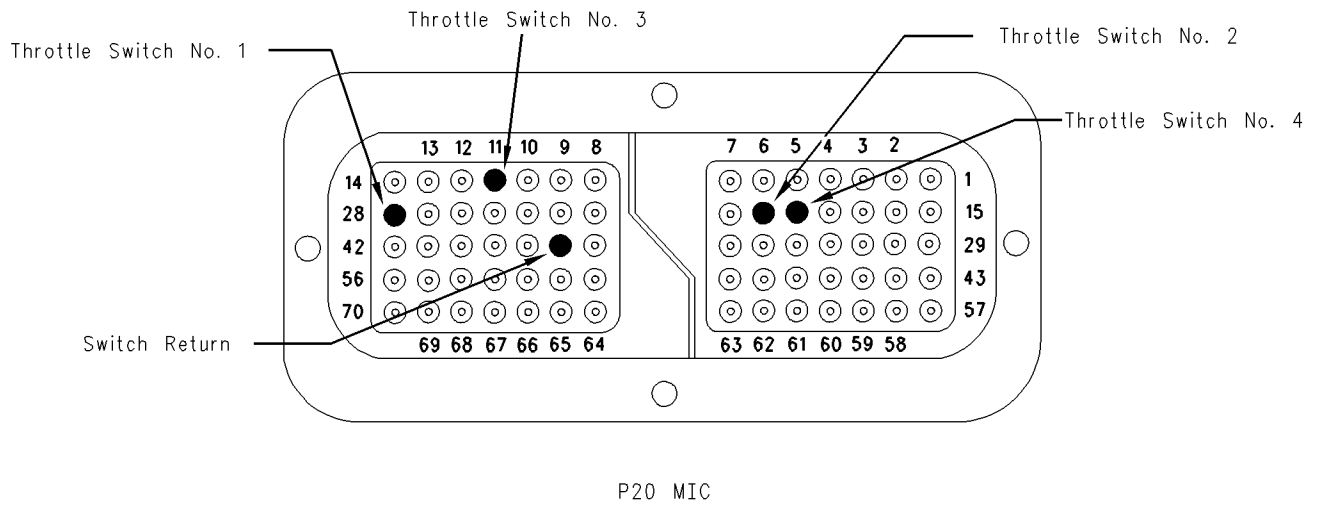

Illustration 126

g00977350

- A. Use a suitable piece of wire to short P20:37 Switch Return to the terminal of the suspect throttle input at J20/P20 MIC.
- B. Measure the resistance between P20:37 (Digital Return) and the terminal for the suspect throttle input at ECM connector P1.

Expected Result:

Resistance should be less than 10 ohms.

Results:

- OK – Proceed to Test Step 6.
- Not OK – There is an open circuit or excessive resistance in the harness.

Repair: Repair the circuit.

Verify that the repair eliminates the problem.

STOP.

Test Step 6. Check the Harness and the ECM

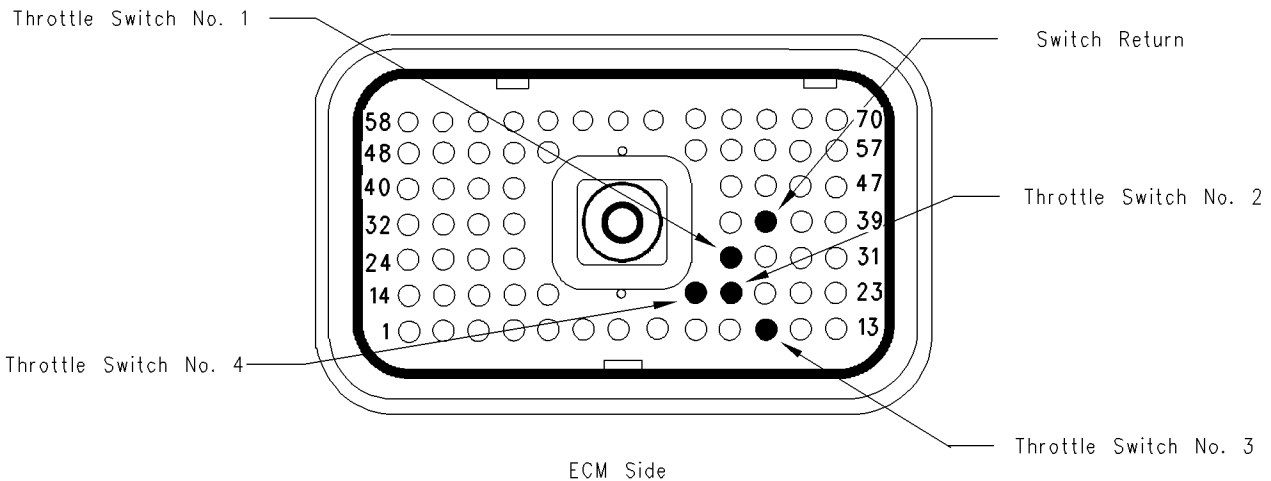

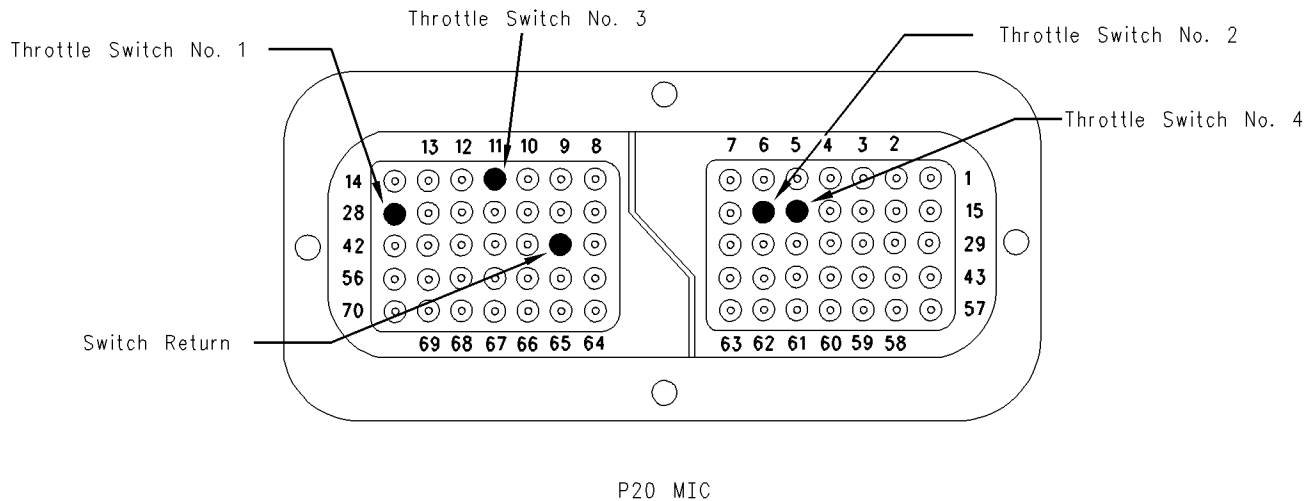

Illustration 128

g00977350

- A. Turn the keyswitch to the OFF position.
- B. Disconnect ECM connector J1/P1 and remove the wire for the suspect throttle input from ECM connector P1.
- C. Reconnect all connectors.
- D. Turn the keyswitch to the ON position.
- E. Observe the status of the suspect throttle input on the electronic service tool.
- F. Turn the keyswitch to the OFF position.
- G. Disconnect ECM connector J1/P1 and remove the wire from P1:37 Switch Return.
- H. Fabricate a jumper wire with pins at both ends. Insert the jumper wire at P1:37 Switch Return and the suspect throttle input at ECM connector P1.
- I. Reconnect all connectors.
- J. Turn the keyswitch to the ON position.

Note: Additional diagnostic codes will be generated because P1:37 Digital Return will no longer be connected to other sensors and switches. Ignore the codes and clear the codes when you complete this test.

- K. Observe the status of the suspect throttle input on the electronic service tool.
- L. Turn the keyswitch to the OFF position.
- M. Remove the jumper wire from ECM connector P1 and reconnect all wires and connectors.

Expected Result:

The status of the suspect throttle input should be "OFF" when the jumper wire is not installed. The status should be "ON" when the jumper wire is installed.

Results:

- OK – There is a problem in the harness between the ECM and the throttle switch.

Repair: Repair the circuit.

Verify that the repair eliminates the problem.

STOP.

- Not OK – The switch signal appears at the ECM. The ECM is not reading the switch properly.

Repair: Verify your results. Replace the ECM.
Refer to Troubleshooting, "Replacing the ECM"
before replacing the ECM.

STOP.

Index

Numerics

5 Volt Engine Pressure Sensor Supply Circuit - Test 92

A

Air Inlet Heater Circuit - Test..... 99
 Alternator Noise (Noisy Operation)..... 35
 Probable Causes 35
 Recommended Actions..... 35
 Alternator Will Not Charge (Charging Problem) 35
 Probable Causes 35
 Recommended Actions..... 35
 Analog Throttle Position Sensor Circuit - Test..... 104

B

Battery 35
 Probable Causes 35
 Recommended Actions..... 36

C

CAN Data Link Circuit - Test..... 113
 Can Not Reach Top Engine RPM..... 36
 Probable Causes 36
 Recommended Actions..... 36
 CID 0041 FMI 03 8v Sensor Power Supply, Voltage More Than Normal..... 64
 CID 0041 FMI 04 8v Sensor Power Supply, Voltage Less Than Normal 64
 CID 0091 FMI 02 Throttle Demand Sensor Erratic Or Intermittent..... 64
 CID 0091 FMI 03 Throttle Demand Sensor Open Circuit Or Shorted High..... 65
 CID 0091 FMI 04 Throttle Demand Sensor Shorted Low 65
 CID 0091 FMI 08 Throttle Demand Sensor Abnormal Signal..... 66
 CID 0091 FMI 12 Throttle Demand Sensor Out Of Calibration..... 66
 CID 0100 FMI 03 Engine Oil Pressure Sensor Open Circuit Or Shorted High..... 66
 CID 0100 FMI 04 Engine Oil Pressure Sensor Shorted Low..... 67
 CID 0100 FMI 10 Engine Oil Pressure Sensor, Power Supply Open Circuit..... 67
 CID 0102 FMI 03 Intake Manifold Pressure Sensor, Open Circuit Or Shorted High..... 67
 CID 0102 FMI 04 Intake Manifold Pressure Sensor Shorted Low..... 68
 CID 0102 FMI 10 Intake Manifold Pressure Sensor Power Supply Open Circuit..... 68
 CID 0105 FMI 03 Intake Manifold Temperature Sensor Open Circuit Or Shorted High 69

CID 0105 FMI 04 Intake Manifold Temperature Sensor Shorted Low 69
 CID 0110 FMI 03 Engine Coolant Temperature Sensor Open Circuit Or Shorted High 69
 CID 0110 FMI 04 Engine Coolant Temperature Sensor Shorted Low 70
 CID 0174 FMI 02 Fuel Temperature Sensor Erratic, Intermittent..... 70
 CID 0247 FMI 09 J1939 Datalink, Abnormal Update 71
 CID 0253 FMI 02 Incorrect ECM Software 71
 CID 0262 FMI 03 5v Sensor Power Supply, Voltage More Than Normal..... 71
 CID 0262 FMI 04 5v Sensor Power Supply, Voltage Less Than Normal 72
 CID 0266 FMI 02 Incorrect Crank-without-inject inputs 72
 CID 0320 FMI 02 Speed And Timing Sensor Intermittent Loss Of Signal 73
 CID 0320 FMI 11 Speed And Timing Sensor Loss Of Signal..... 73
 CID 0342 FMI 02 Speed And Timing Sensor No.2 Intermittent Signal..... 73
 CID 0774 FMI 02 Throttle Demand Sensor No.2 Erratic Or Intermittent 74
 CID 0774 FMI 03 Throttle Demand Sensor No.2 Open Circuit Or Shorted High..... 74
 CID 0774 FMI 04 Throttle Demand Sensor No.2 Shorted Low..... 75
 CID 0774 FMI 08 Throttle Demand Sensor No.2 Abnormal Signal 75
 CID 0774 FMI 12 Throttle Demand Sensor No.2 Out Of Calibration..... 75
 CID 1627 FMI 03 Fuel Injection Pump Relay Did Not Turn Off..... 76
 CID 1684 FMI 00 Fuel Injection Pump, Fuel Temperature More Than Normal..... 76
 CID 1684 FMI 02 Fuel Injection Pump, Software Failure..... 77
 CID 1684 FMI 03 Fuel Injection Pump, Fuelling Fault..... 77
 CID 1684 FMI 04 Fuel Injection Pump, Supply Voltage Fault..... 77
 CID 1684 FMI 05 Fuel Injection Pump, Invalid Pulse Width..... 78
 CID 1684 FMI 07 Fuel Injection Pump, Mechanical Fault..... 78
 CID 1684 FMI 08 Fuel Injection Pump, Crankshaft Reference Fault 79
 CID 1684 FMI 09 Fuel Injection Pump, CAN Fault..... 80
 CID 1684 FMI 10 Fuel Injection Pump, Fuel Shutoff Signal Error..... 80
 CID 1684 FMI 11 Fuel Injection Pump, Internal Sensor Fault 81
 CID 1684 FMI 12 Fuel Injection Pump, Device Failure..... 81
 CID 1684 FMI 14 Fuel Injection Pump, No Communications 82

| | | | |
|--|-----|---|-----|
| CID 1743 FMI 02 Engine Speed Mode Selection Switch State, Invalid State | 83 | Engine Misfires, Runs Rough or Is Unstable..... | 43 |
| CID 1894 FMI 02 Set Speed Control Disengage Switch State, Invalid State | 83 | Probable Causes | 44 |
| CID 1895 FMI 02 Set Speed Control Speed Toggle Switch, Invalid State | 83 | Recommended Actions | 44 |
| Coolant in Engine Oil..... | 38 | Engine Oil in Cooling System | 46 |
| Probable Causes | 38 | Probable Causes | 46 |
| Recommended Actions..... | 38 | Recommended Actions..... | 46 |
| Coolant Temperature Is Too High | 39 | Engine Oil Level Switch Circuit - Test..... | 152 |
| Probable Causes | 39 | Engine Pressure Sensor Open or Short Circuit - Test | 157 |
| Recommended Actions..... | 39 | Engine Speed Does Not Change | 46 |
| D | | Probable Causes | 46 |
| Data Link Circuit - Test | 118 | Recommended Repairs | 46 |
| Diagnostic Codes | 13 | Engine Speed/Timing Sensor Circuit - Test..... | 164 |
| Diagnostic Functional Tests..... | 92 | Engine Stalls at Low RPM..... | 47 |
| Digital Throttle Position Sensor Circuit - Test | 126 | Probable Causes | 47 |
| | | Recommended Actions..... | 47 |
| E | | Engine Temperature Sensor Open or Short Circuit - Test | 171 |
| E015 High Engine Coolant Temperature Derate ... | 85 | Engine Vibration | 48 |
| E016 High Engine Coolant Temperature Shutdown..... | 85 | Probable Causes | 48 |
| E017 High Engine Coolant Temperature Warning.. | 85 | Recommended Actions..... | 48 |
| E025 High Intake Air Temperature Derate..... | 86 | Engine Will Not Crank | 49 |
| E027 High Intake Air Temperature Warning | 86 | Probable Causes | 49 |
| E040 Low Engine Oil Pressure Shutdown..... | 86 | Recommended Repairs | 49 |
| E054 High Fuel Temperature Derate..... | 87 | Engine Wiring Information | 26 |
| E056 High Fuel Temperature Warning | 88 | Harness Wire Identification..... | 31 |
| E100 Low Engine Oil Pressure Warning | 89 | Machine Interface Connector..... | 26 |
| E190 Engine Overspeed Warning | 90 | Event Codes | 85 |
| E442 Engine Failed to Stop with a No-Fuel Command | 90 | Programmable Engine Parameters..... | 85 |
| E883 Engine Failed To Stop When Fuel Solenoid Disengaged..... | 91 | Excessive Black Smoke | 50 |
| ECM Will Not Accept Factory Passwords..... | 40 | Probable Causes | 50 |
| Probable Causes | 40 | Recommended Actions..... | 50 |
| Recommended Actions..... | 40 | Excessive Engine Oil Consumption..... | 51 |
| ECM Will Not Communicate with Other Systems or Display Modules | 40 | Probable Causes | 51 |
| Probable Causes | 40 | Recommended Actions..... | 51 |
| Recommended Actions..... | 40 | Excessive Valve Lash..... | 52 |
| Electrical Connectors - Inspect..... | 135 | Probable Causes | 52 |
| Electrical Power Supply Circuit - Test..... | 146 | Recommended Actions..... | 52 |
| Electronic Service Tool Will Not Communicate with ECM..... | 40 | Excessive White Smoke | 53 |
| Probable Causes | 40 | Probable Causes | 53 |
| Recommended Actions..... | 41 | Recommended Actions..... | 53 |
| Electronic Service Tools | 12 | F | |
| Electronic Service Tool..... | 12 | Factory Passwords | 32 |
| Electronic Troubleshooting | 5 | Customer Passwords..... | 32 |
| Engine Cranks but Will Not Start..... | 41 | Factory Passwords | 32 |
| Probable Causes | 41 | Passwords | 32 |
| Recommended Actions..... | 41 | Flash Programming | 32 |
| Engine Has Early Wear | 43 | Flash Programming a Personality Module | 33 |
| Probable Causes | 43 | Fuel Injection Pump Circuit - Test..... | 178 |
| Recommended Actions..... | 43 | | |
| | | G | |
| | | Glossary | 9 |

| | | | |
|---|-----|---|-----|
| I | | System Configuration Parameters..... | 34 |
| Important Safety Information | 2 | “ECM Software Release Date”..... | 34 |
| Indicator Lamp Circuit - Test..... | 195 | “Engine Serial Number” | 34 |
| Indicator Lamps | 15 | “Full Load Setting”..... | 34 |
| Use the lamps to check the engine’s operational status or the existence of any engine faults. | 16 | “Full Torque Setting”..... | 34 |
| Use the lamps to identify active diagnostic codes..... | 17 | Rating Interlock | 34 |
| Intake Air Temperature Is Too High | 54 | System Overview..... | 5 |
| Probable Causes | 54 | Diagnostic Codes..... | 8 |
| Recommended Repairs | 54 | Passwords | 8 |
| Intermittent Engine Shutdown | 55 | Programmable Parameters..... | 8 |
| Probable Causes | 55 | System Operation | 5 |
| Recommended Actions..... | 55 | T | |
| Intermittent Low Power or Power Cutout..... | 56 | Table of Contents..... | 3 |
| Probable Causes | 56 | Throttle Switch Circuit - Test..... | 212 |
| Recommended Repairs | 56 | Troubleshooting Section..... | 5 |
| L | | Troubleshooting with a Diagnostic Code | 64 |
| Low Engine Oil Pressure | 58 | Troubleshooting with an Event Code..... | 85 |
| Probable Causes | 58 | Troubleshooting without a Diagnostic Code | 35 |
| Recommended Actions..... | 58 | | |
| Low Power/Poor or No Response to Throttle | 59 | | |
| Probable Causes | 59 | | |
| Recommended Actions..... | 59 | | |
| M | | | |
| Mechanical Noise (Knock) in Engine..... | 61 | | |
| Probable Causes | 61 | | |
| Recommended Actions..... | 61 | | |
| Mode Selection Circuit - Test..... | 198 | | |
| N | | | |
| Noise Coming from Cylinder..... | 61 | | |
| Probable Causes | 61 | | |
| Recommended Actions..... | 61 | | |
| P | | | |
| Poor Acceleration or Response..... | 62 | | |
| Probable Causes | 62 | | |
| Recommended Repairs | 62 | | |
| Programming Parameters | 32 | | |
| R | | | |
| Replacing the ECM..... | 18 | | |
| S | | | |
| Self-Diagnostics..... | 19 | | |
| Sensors and Electrical Connectors | 20 | | |
| Set Speed Circuit - Test..... | 204 | | |

