

PART NO. TO1J7-E-00

**HITACHI**

# **Technical Manual**

## **Operational Principle**

# **ZAXIS**

# **650LC-3**

# **670LCH-3**

## **Hydraulic Excavator**

**Hitachi Construction Machinery**  
www.hitachi-c-m.com

PRINTED IN EUROPE (YC) 2006.03

This Service Manual consists of three separate parts:  
Technical Manual (Operational Principle)  
Technical Manual (Troubleshooting)  
Workshop Manual (Workshop Manual in English only)

Part No. TO1J7-E-00  
Part No. TT1J7-E-00  
Part No. W1J7-E-00

ZAXIS 650LC-3 • 670LCH-3

HYDRAULIC EXCAVATOR

TECHNICAL MANUAL

OPERATIONAL PRINCIPLE

TO1J7-E-00

# INTRODUCTION

---

## TO THE READER

- This manual is written for an experienced technician to provide technical information needed to maintain and repair this machine.
- Be sure to thoroughly read this manual for correct product information and service procedures.
- If you have any questions or comments, at if you found any errors regarding the contents of this manual, please contact using "Service Manual Revision Request Form" at the end of this manual.  
(Note: Do not tear off the form. Copy it for usage.)  
Publications Marketing & Product Support  
Hitachi Construction Machinery Co. Ltd.  
TEL: 81-298-32-7173  
FAX: 81-298-31-1162

---

## ADDITIONAL REFERENCES

- Please refer to the materials listed below in addition to this manual.
  - The Operator's Manual
  - The Parts Catalog
  - Operation Manual of the Engine
  - Parts Catalog of the Engine
  - Hitachi Training Material

---

## MANUAL COMPOSITION

- This manual consists of three portions: the Technical Manual (Operational Principle), the Technical Manual (Troubleshooting) and the Workshop Manual.
- Information included in the Technical Manual (Operational Principle):  
technical information needed for redelivery and delivery, operation and activation of all devices and systems.
- Information included in the Technical Manual (Troubleshooting):  
technical information needed for operational performance tests, and troubleshooting procedures.
- Information included in the Workshop Manual:  
technical information needed for maintenance and repair of the machine, tools and devices needed for maintenance and repair, maintenance standards, and removal/installation and assemble/disassemble procedures.

---

## PAGE NUMBER

- Each page has a number, located on the center lower part of the page, and each number contains the following information:

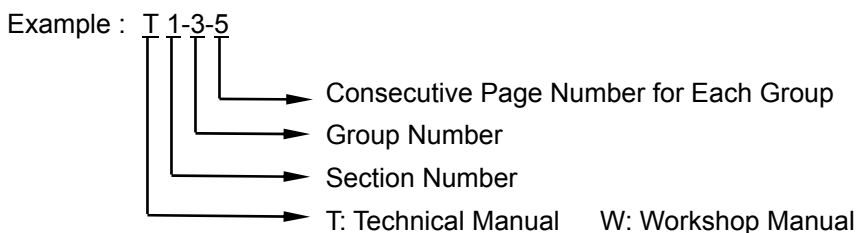

# INTRODUCTION

---

## SAFETY ALERT SYMBOL AND HEADLINE NOTATIONS

In this manual, the following safety alert symbol and signal words are used to alert the reader to the potential for personal injury or machine damage.

 This is the safety alert symbol. When you see this symbol, be alert to the potential for personal injury. Never fail to follow the safety instructions prescribed along with the safety alert symbol.

The safety alert symbol is also used to draw attention to component/part weights.

To avoid injury and damage, be sure to use appropriate lifting techniques and equipment when lifting heavy parts.

-  **CAUTION:**  
Indicated potentially hazardous situation which could, if not avoided, result in personal injury or death.

- **IMPORTANT:**  
Indicates a situation which, if not conformed to the instructions, could result in damage to the machine.

-  **NOTE:**  
Indicates supplementary technical information or know-how.

---

## UNITS USED

- SI Units (International System of Units) are used in this manual. MKSA system units and English units are also indicated in parentheses just behind SI units.

Example : 24.5 MPa (250 kgf/cm<sup>2</sup>, 3560 psi)

A table for conversion from SI units to other system units is shown below for reference purposes.

Quantity	To Convert From	Into	Multiply By	Quantity	To Convert From	Into	Multiply By
Length	mm	in	0.03937	Pressure	MPa	kgf/cm <sup>2</sup>	10.197
	mm	ft	0.003281		MPa	psi	145.0
Volume	L	US gal	0.2642	Power	kW	PS	1.360
	L	US qt	1.057		kW	HP	1.341
	m <sup>3</sup>	yd <sup>3</sup>	1.308	Temperature	°C	°F	°C×1.8+32
Weight	kg	lb	2.205	Velocity	km/h	mph	0.6214
Force	N	kgf	0.10197		min <sup>-1</sup>	rpm	1.0
	N	lbf	0.2248	Flow rate	L/min	US gpm	0.2642
Torque	N·m	kgf·m	1.0197		mL/rev	cc/rev	1.0
	N·m	lbf·ft	0.7375				

## SECTION AND GROUP CONTENTS

## TECHNICAL MANUAL

(Operational Principle)

## SECTION 1 GENERAL

Group 1 Specification

Group 2 Component Layout

Group 3 Component Specifications

## SECTION 2 SYSTEM

Group 1 Control System

Group 2 Control System

Group 3 ECM System

Group 4 Hydraulic System

Group 5 Electrical System

## SECTION 3 COMPONENT OPERATION

Group 1 Pump Device

Group 2 Swing Device

Group 3 Control Valve

Group 4 Pilot Valve

Group 5 Travel Device

Group 6 Signal Control Valve

Group 7 Others (Upperstructure)

Group 8 Others (Undercarriage)

## TECHNICAL MANUAL (Troubleshooting)

### SECTION 4 OPERATIONAL PERFORMANCE TEST

Group 1 Introduction

Group 2 Standard

Group 3 Engine Test

Group 4 Excavator Test

Group 5 Component Test

### SECTION 5 TROUBLESHOOTING

Group 1 Diagnosing Procedure

Group 2 Monitor Unit

Group 3 Dr. ZX

Group 4 e-Shovel

Group 5 Component Layout

Group 6 Troubleshooting A

Group 7 Troubleshooting B

Group 8 Electrical System Inspection

*All information, illustrations and specifications in this manual are based on the latest product information available at the time of publication. The right is reserved to make changes at any time without notice.*

---

## **WORKSHOP MANUAL**

### **SECTION 1 GENERAL INFORMATION**

- Group 1 Precautions for Disassembling and Assembling
- Group 2 Tightening Torque
- Group 3 Painting
- Group 4 Bleeding Air from Hydraulic Oil Tank

### **SECTION 2 UPPERSTRUCTURE**

- Group 1 Cab
- Group 2 Counterweight
- Group 3 Main Frame
- Group 4 Pump Device
- Group 5 Control Valve
- Group 6 Swing Device
- Group 7 Pilot Valve
- Group 8 Pilot Shut-Off Valve
- Group 9 Signal Control Valve
- Group 10 Solenoid Valve

### **SECTION 3 UNDERCARRIAGE**

- Group 1 Swing Bearing
- Group 2 Travel Device
- Group 3 Center Joint
- Group 4 Track Adjuster
- Group 5 Front Idler
- Group 6 Upper and Lower Roller
- Group 7 Track

### **SECTION 4 FRONT ATTACHMENT**

- Group 1 Front Attachment
  - Group 2 Cylinder
-

---

---

# SECTION 1 GENERAL

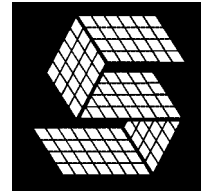

## —CONTENTS—

### Group 1 Specifications

Specifications .....	T1-1-1
Working Ranges .....	T1-1-3

### Group 2 Component Layout

Main Component Layout.....	T1-2-1
Electrical Component Layout.....	T1-2-3
Engine .....	T1-2-9
Pump Device .....	T1-2-10
Swing Device.....	T1-2-10
Travel Device.....	T1-2-10
Control Valve .....	T1-2-11

### Group 3 Component Specifications

Engine .....	T1-3-1
Engine Accessories .....	T1-3-4
Hydraulic Component.....	T1-3-5
Electrical Component .....	T1-3-9

---

---

(Blank)

## GENERAL / Specifications

### SPECIFICATION

ZAXIS650LC-3

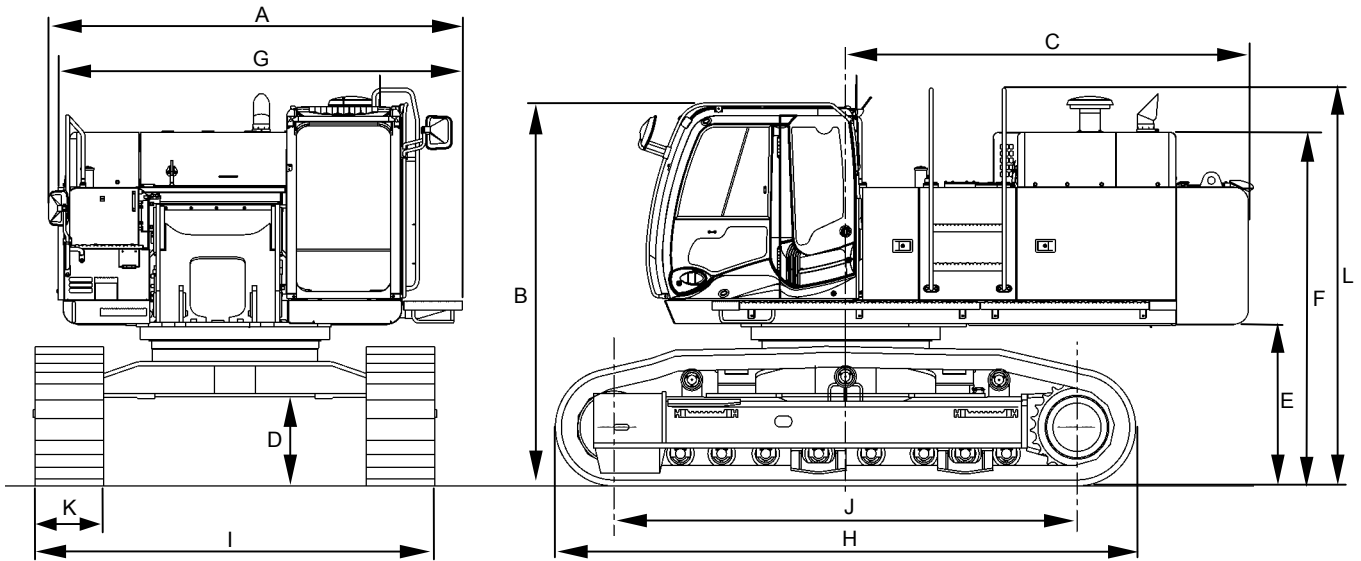

M1J1-12-001

Model	ZX650LC-3 Hydraulic Excavator
Type of Front-End Attachment	3.6 m (11 ft 10 in) Arm
Bucket Capacity (Heaped)	PCSA 2.9 m <sup>3</sup> (3.8 yd <sup>3</sup> ) (CECE 1.7 m <sup>3</sup> )
Operating Weight	65900 kg (145300 lb)
Basic Machine Weight	50800 kg (112000 lb)
Engine	ISUZU AH-6WG1XYSA-02 345 kW/1800 min <sup>-1</sup> (469 PS/1800 rpm)
A: Overall Width (Excluding Rear View Mirrors)	4340 mm (14 ft 3 in)
B: Cab Height	3450 mm (11 ft 4 in)
C: Rear End Swing Radius	3850 mm (12 ft 8 in)
D: Minimum Ground Clearance	*860 mm (2 ft 10 in)
E: Counterweight Clearance	*1530 mm (5 ft 0 in)
F: Engine Cover Height	3260 mm (10 ft 8 in)
G: Overall Width of Upperstructure	4100 mm (13 ft 5 in)
H: Undercarriage Length	5840 mm (19 ft 2 in)
I: Undercarriage Width	3950 mm (12 ft 12 in)/ 3480 mm (11 ft 5 in)
J: Sprocket Center to Idler Center	4590 mm (15 ft 1 in)
K: Track Shoe Width	650 mm (26 in) (Grouser shoe)
L: Overall Height	3900 mm (12 ft 10 in)
Ground Pressure	99 kPa (1.01 kgf/cm <sup>2</sup> , 14.4 psi)
Swing Speed	9.5 min <sup>-1</sup> (rpm)
Travel Speed (fast/slow)	4.9 km/h (3.0 mph)/ 3.4 km/h (2.1 mph)
Gradeability	35 ° (tan θ = 0.70)

NOTE: "\*" The dimensions do not include the height of the shoe lug.



# GENERAL / Specifications

## WORKING RANGES

### ZAXIS650LC-3

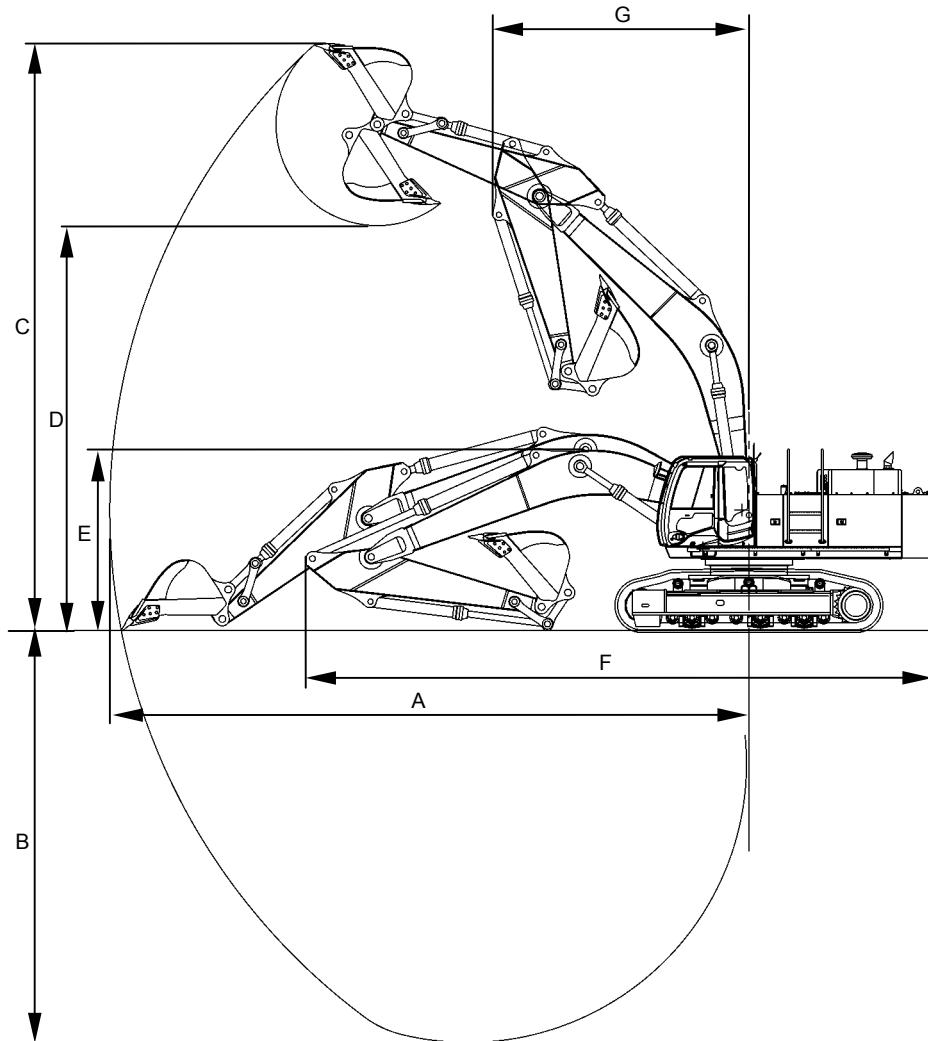

M1J1-12-002

Item	Category	ZX650LC-3		
		7.8 m (25 ft 7 in) Boom		6.8 m (22 ft 4 in) BE Boom
		3.6 m (11 ft 10 in) Arm	4.2 m (13 ft 9 in) Arm	2.9 m (9 ft 6 in) BE Arm
A: Maximum Digging Reach	mm (ft-in)	13250 (43'6")	13850 (45'5")	13250 (43'6")
B: Maximum Digging Depth	mm (ft-in)	8530 (27'12")	9150 (30'0")	7120 (23'4")
C: Maximum Cutting Height	mm (ft-in)	11190 (36'9")	12240 (40'2")	11190 (36'9")
D: Maximum Dumping Height	mm (ft-in)	8050 (26'5")	8330 (27'4")	7330 (24'1")
E: Transport Height	mm (ft-in)	*4460 (14'8")		
F: Overall Transport Length	mm (ft-in)	*13200 (43'4")		
G: Minimum Swing Radius	mm (ft-in)	5780 (18'12")	5760 (18'11")	5240 (17'2")

**NOTE:** "\*" The dimensions include the height of the shoe lug.

## GENERAL / Specifications

### SPECIFICATION

ZAXIS670LCH-3

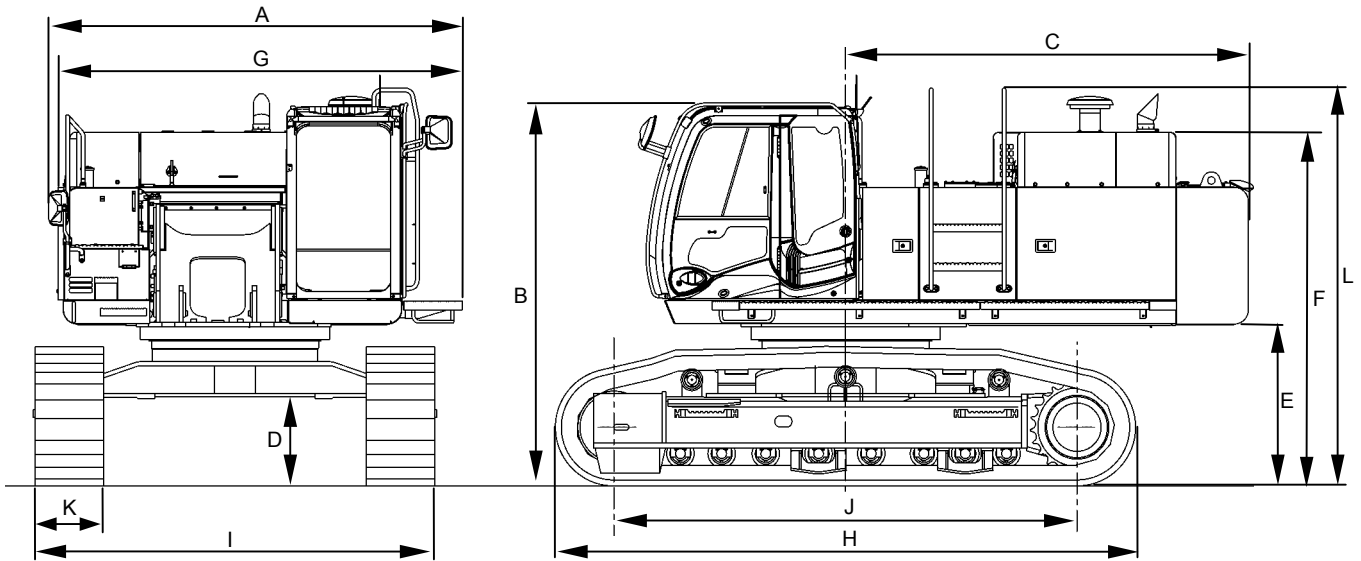

M1J1-12-001

Model	ZX670LC-3 Hydraulic Excavator
Type of Front-End Attachment	H Front (with 3.6 m (11 ft 10 in) Arm)
Bucket Capacity (Heaped)	PCSA 2.9 m <sup>3</sup> (3.8 yd <sup>3</sup> ) (CECE 2.5 m <sup>3</sup> )
Operating Weight	67300 kg (148400 lb)
Basic Machine Weight	51500 kg (113500 lb)
Engine	ISUZU AH-6WG1XYSA-02 345 kW/1800 min <sup>-1</sup> (469 PS/1800 rpm)
A: Overall Width (Excluding Rear View Mirrors)	4340 mm (14 ft 3 in)
B: Cab Height	
C: Rear End Swing Radius	3850 mm (12 ft 8 in)
D: Minimum Ground Clearance	*860 mm (2 ft 10 in)
E: Counterweight Clearance	*1530 mm (5 ft 0 in)
F: Engine Cover Height	3260 mm (10 ft 8 in)
G: Overall Width of Upperstructure	4100 mm 13 ft 5 in)
H: Undercarriage Length	5840 mm (19 ft 2 in)
I: Undercarriage Width	3950 mm (12 ft 12 in)/ 3480 mm (11 ft 5 in)
J: Sprocket Center to Idler Center	4590 mm (15 ft 1 in)
K: Track Shoe Width	650 mm (26 in) (Grouser shoe)
L: Overall Height	3900 mm (12 ft 10 in)
Ground Pressure	101 kPa (1.03 kgf/cm <sup>2</sup> , 14.6 psi)
Swing Speed	9.5 min <sup>-1</sup> (rpm)
Travel Speed (fast/slow)	4.9 km/h (3.0 mph)/ 3.4 km/h (2.1 mph)
Gradeability	35 ° (tan θ = 0.70)

NOTE: "\*" The dimensions do not include the height of the shoe lug.

## GENERAL / Specifications

### WORKING RANGES

#### ZAXIS670LCH-3

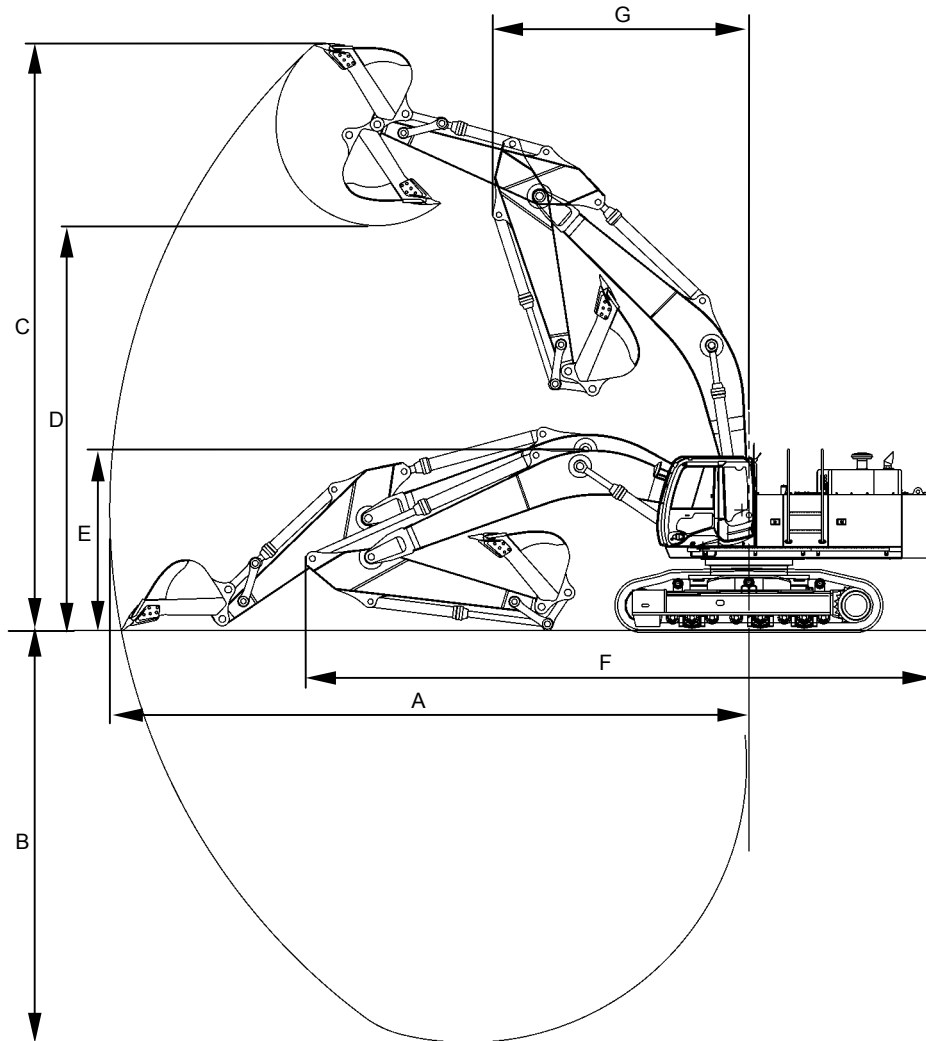

M1J1-12-002

Item	Category	ZX670LCH-3	
		7.8 m (25 ft 7 in) H Boom	6.8 m (22 ft 4 in) BE Boom
		3.6 m (11 ft 10 in) H Boom	2.9 m (9 ft 6 in) BE Arm
A: Maximum Digging Reach	mm (ft-in)	13280 (43'7")	11800 (38'9")
B: Maximum Digging Depth	mm (ft-in)	7120 (23'4")	7120 (23'4")
C: Maximum Cutting Height	mm (ft-in)	11940 (39'2")	11190 (36'9")
D: Maximum Dumping Height	mm (ft-in)	8020 (26'4")	7330 (24'1")
E: Transport Height	mm (ft-in)	*4460 (14'8")	
F: Overall Transport Length	mm (ft-in)	*13200 (43'4")	
G: Minimum Swing Radius	mm (ft-in)	5780 (18'12")	5240 (17'2")

**NOTE:** "\*" The dimensions include the height of the shoe lug.

# GENERAL / Component Layout

## MAIN COMPONENTS

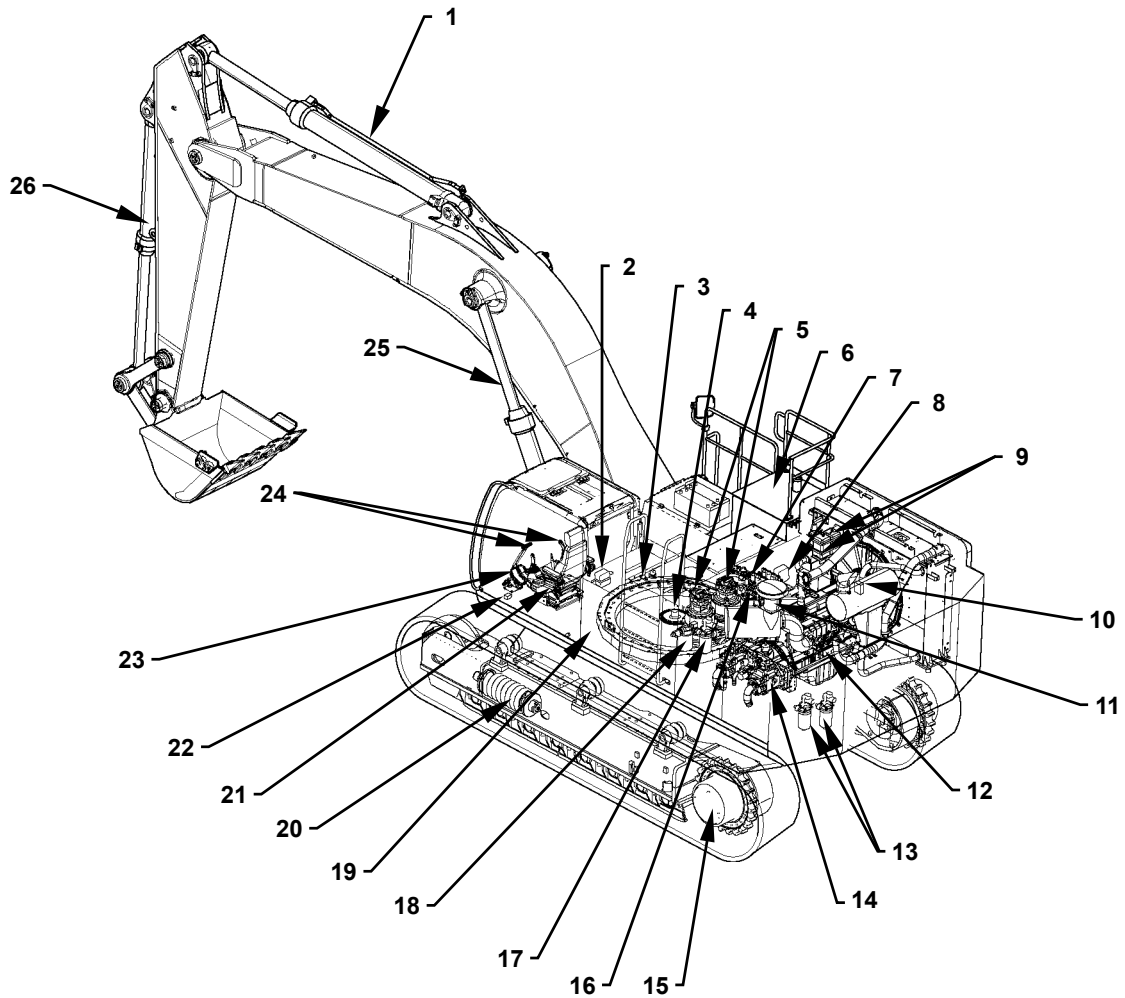

T1J7-01-02-010

- |                   |                          |  |   |
|-------------------|--------------------------|--|---|
| 1 - Arm Cylinder  | 8 - Signal Control Valve | 15 - Travel Device                     | 21 - Shockless Valve                      |
| 2 - Washer Tank   | 9 - Reserve Tank         | 16 - Solenoid Valve Unit               | 22 - Pilot Shut-Off Solenoid Valve        |
| 3 - Swing Bearing | 10 - Fan Motor           | 17 - Pilot Filter / Pilot Relief Valve | 23 - Travel Pilot Valve                   |
| 4 - Center Joint  | 11 - Air Cleaner         | 18 - Drain Filter                      | 24 - Front Attachment / Swing Pilot Valve |
| 5 - Swing Device  | 12 - Engine              | 19 - Hydraulic Oil Tank                | 25 - Boom Cylinder                        |
| 6 - Fuel Tank     | 13 - Engine Oil Filter   | 20 - Track Adjuster                    | 26 - Bucket Cylinder                      |
| 7 - Control Valve | 14 - Pump Device         |  |   |

# GENERAL / Component Layout

## View A (Around the Radiator)

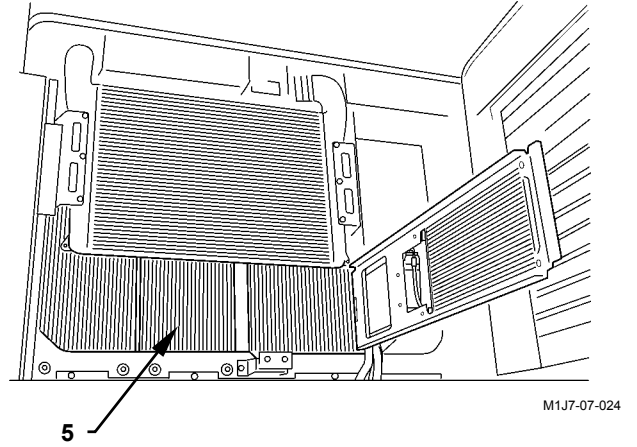
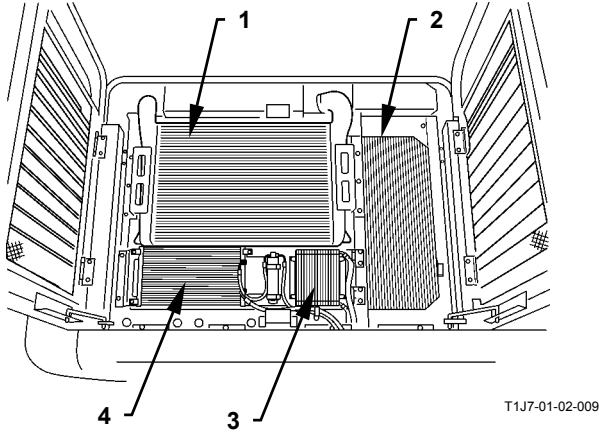

## Control Valve Lower

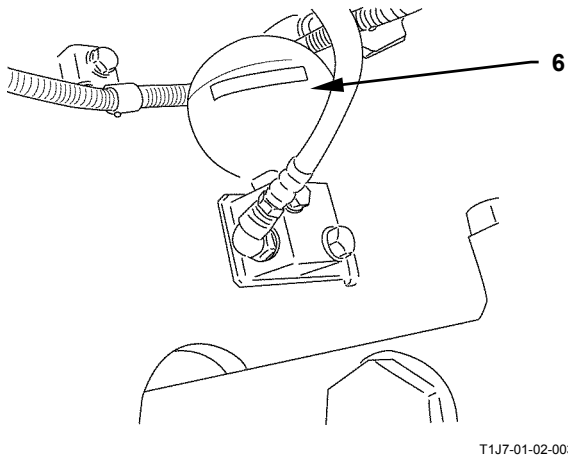

1 - Inter Cooler  
2 - Oil Cooler

3 - Fuel Cooler  
4 - Air Conditioner Condenser

5 - Radiator

6 - Accumulator

# GENERAL / Component Layout

## ELECTRICAL SYSTEM (OVERVIEW)

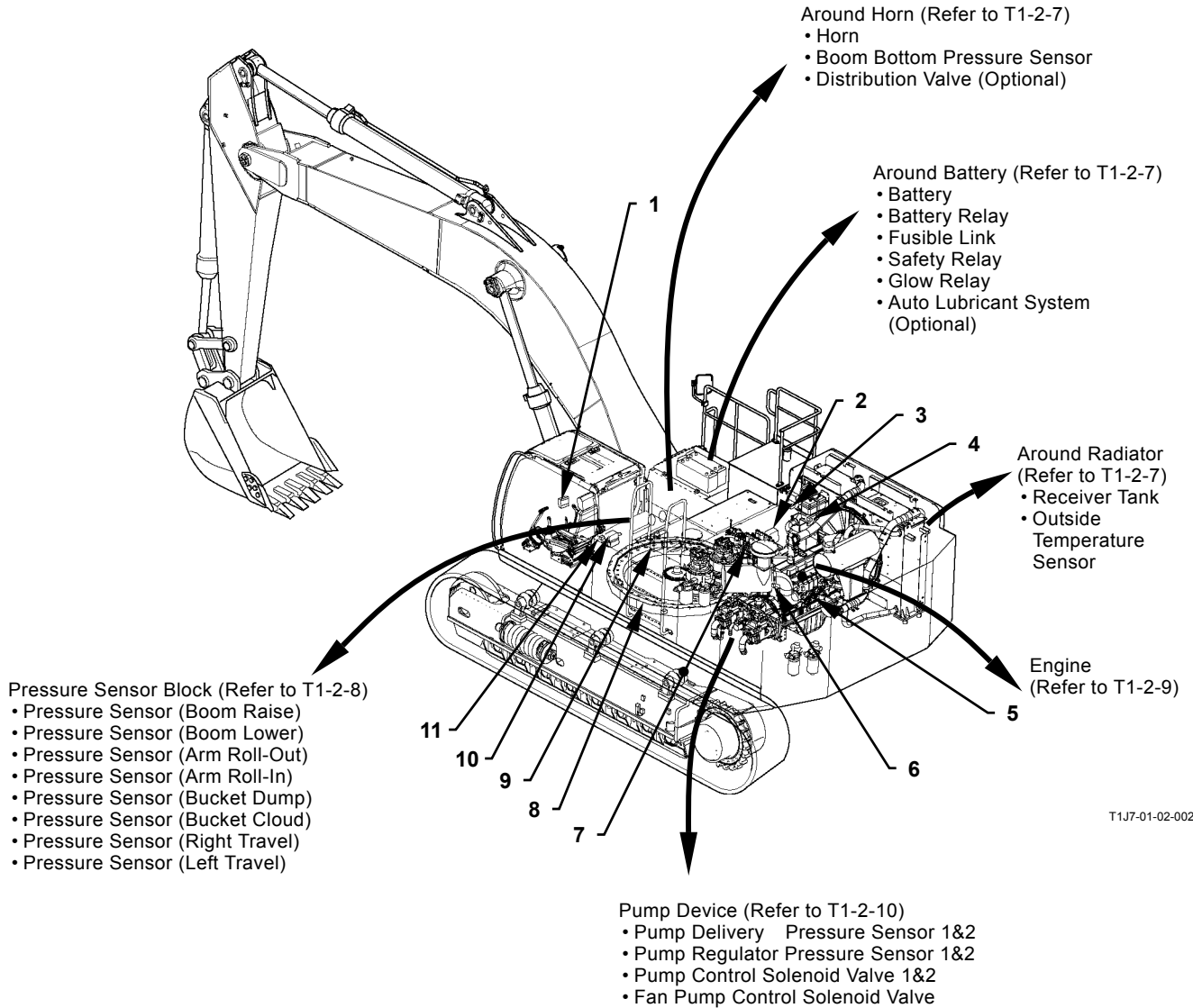

1 - Monitor Unit

4 - Coolant Level Switch

7 - Solenoid Valve Unit  
(Refer to T1-2-8)

10 - Washer Motor

2 - Pressure Sensor (Swing)  
(Refer to T1-2-8)

5 - Intake Air Temperature  
Sensor

8 - Hydraulic Oil Temperature  
Sensor

11 - Atmosphere Pressure  
Sensor

3 - Fuel Sensor

6 - Air Cleaner Restriction  
Switch

9 - ECM (Engine Controller)

# GENERAL / Component Layout

## ELECTRICAL SYSTEM (In Cab)

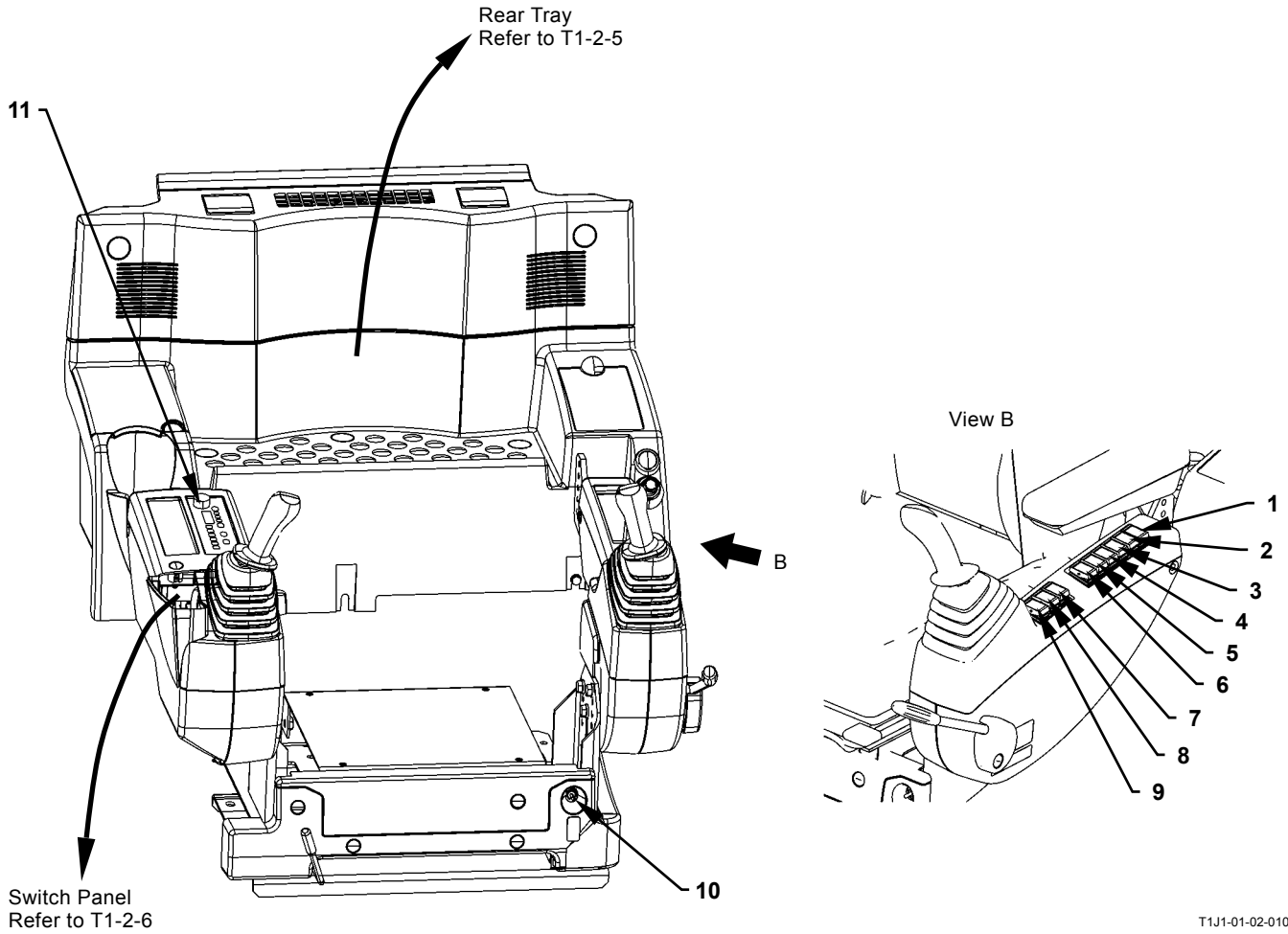

T1J1-01-02-010

- |   |                               |   |                         |
|---|-------------------------------|---|-------------------------|
| 1 - Fan Rotative Direction Select Switch (Optional) | 4 - Auto Lubrication Switch   | 7 - Overload Alarm Switch (Optional)            | 10 - Engine Stop Switch |
| 2 - Beacon Light Switch (Optional)                  | 5 - Level Check Switch        | 8 - Seat Heater Switch (Optional)               | 11 - Radio              |
| 3 - Reverse Light Switch (Optional)                 | 6 - Boom Mode Selector Switch | 9 - Travel Alarm Cancellation Switch (Optional) |                         |

# GENERAL / Component Layout

## ELECTRICAL SYSTEM (Rear Tray)

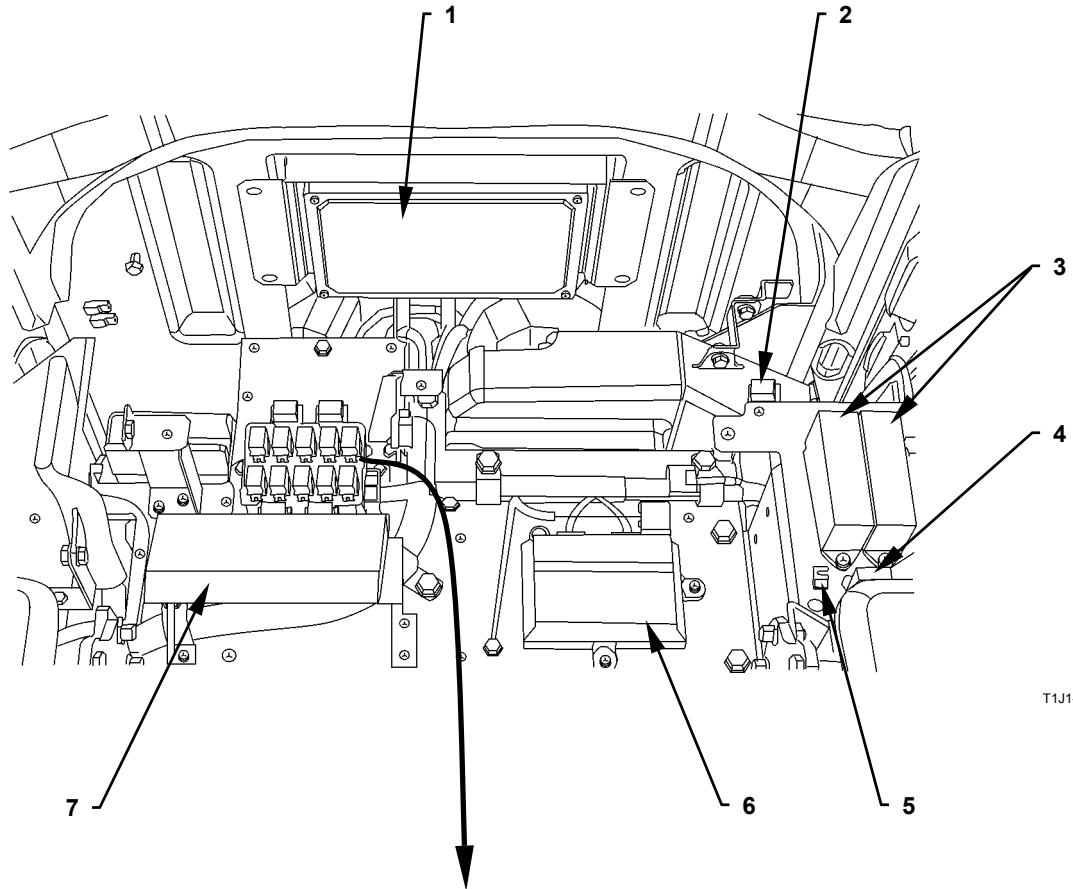

T1J1-01-02-003

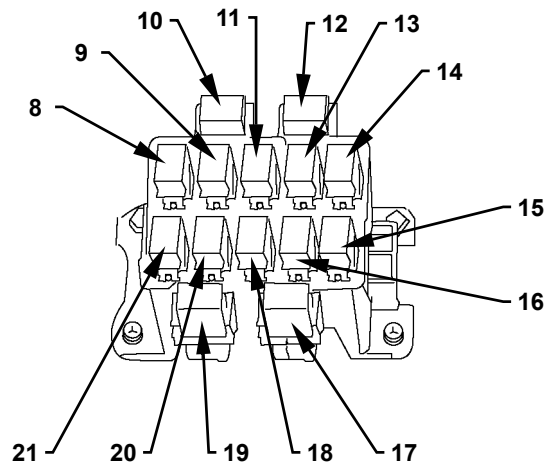

T1V1-01-02-009

- |  |   |  |                                     |
|--|---|--|-------------------------------------|
| 1 - MC(Main Controller)                          | 7 - Satellite Communication Terminal (Optional) | 12 - Auto Lubrication Relay (R11) (Optional) | 17 - Light Relay 3 (R13) (Optional) |
| 2 - Overload Alarm Relay (Optional)              | 8 - Security Relay (R5)                         | 13 - Lock Relay (R2)                         | 18 - Light Relay 2 (R8)             |
| 3 - Fuse Box                                     | 9 - Starter Cut Relay (R4)                      | 14 - Load Damp Relay (R1)                    | 19 - ECM Main Relay (R14)           |
| 4 - Dr. ZX Connector (Use as Download Connector) | 10 - Hour Meter Relay (R12) (Optional)          | 15 - Wiper Relay (R6)                        | 20 - Washer Relay (R9)              |
| 5 - Pump Study Switch                            | 11 - Security Horn Relay (R3)                   | 16 - Light Relay 1 (R7)                      | 21 - Horn Relay (R10)               |
| 6 - ICF (Information Controller)                 |   |  |                                     |



# GENERAL / Component Layout

## ELECTRICAL SYSTEM (Switch Panel)

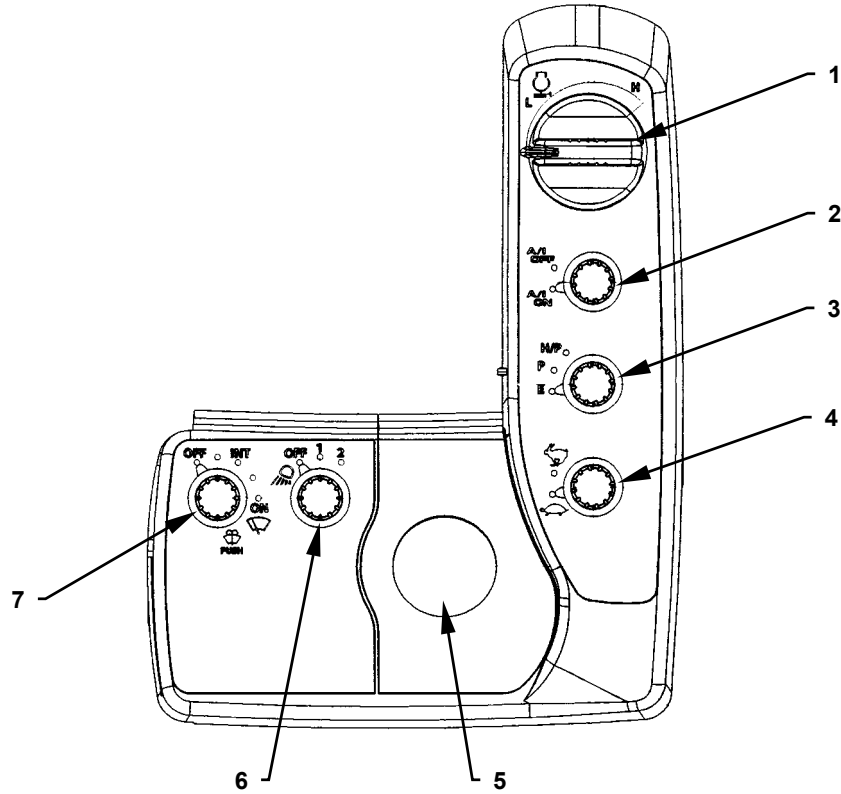

T1V1-04-02-001

1 - Engine Control Dial  
2 - Auto-Idle Switch

3 - Power Mode Switch  
4 - Travel Mode Switch

5 - Key Switch  
6 - Working Light Switch

7 - Wiper/Washer Switch

# GENERAL / Component Layout

## Around Horn

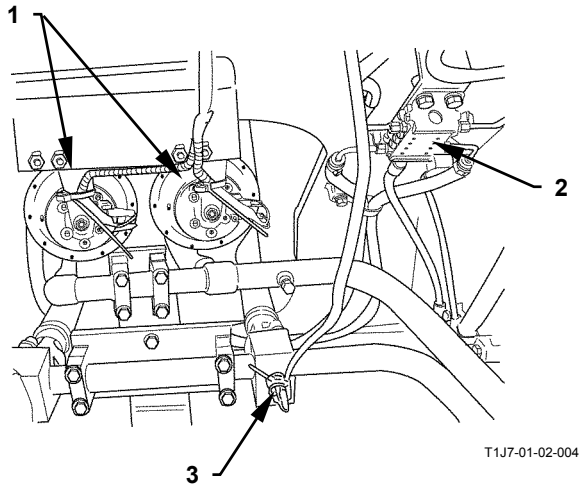

## Around Radiator

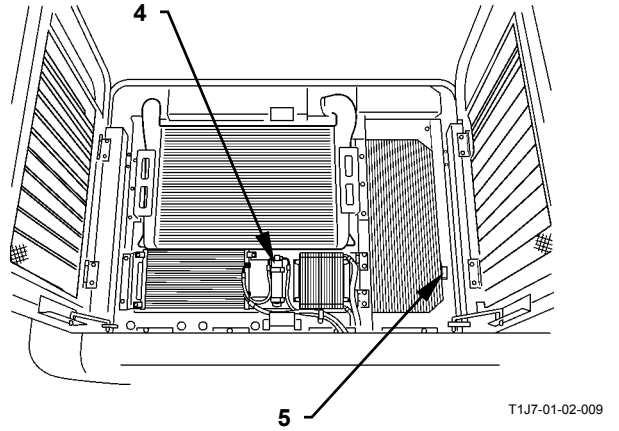

## Around Battery

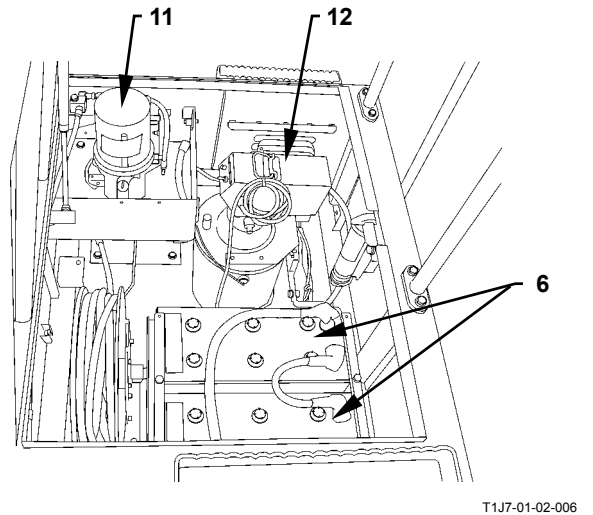
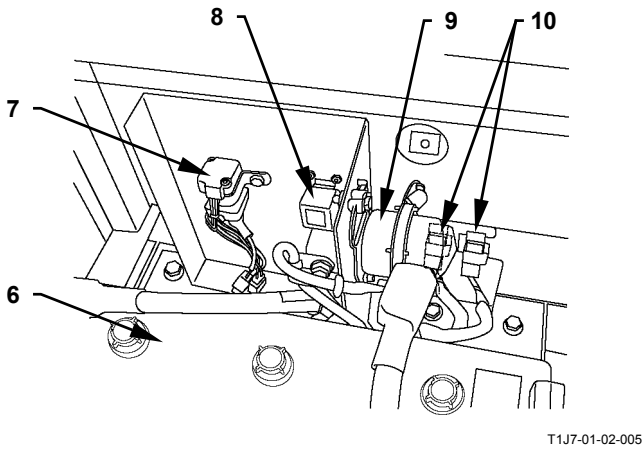

- 1 - Horn
- 2 - Distribution Valve (Optional)
- 3 - Boom Bottom Pressure Sensor
- 4 - Receiver Tank

- 5 - Outside Temperature
- 6 - Battery
- 7 - Glow Relay

- 8 - Safety Relay
- 9 - Battery Relay
- 10 - Fusible Link

- 11 - Grease Pump (Optional)
- 12 - Grease Gun Pump (Optional)

## GENERAL / Component Layout

### Pressure Sensor Block

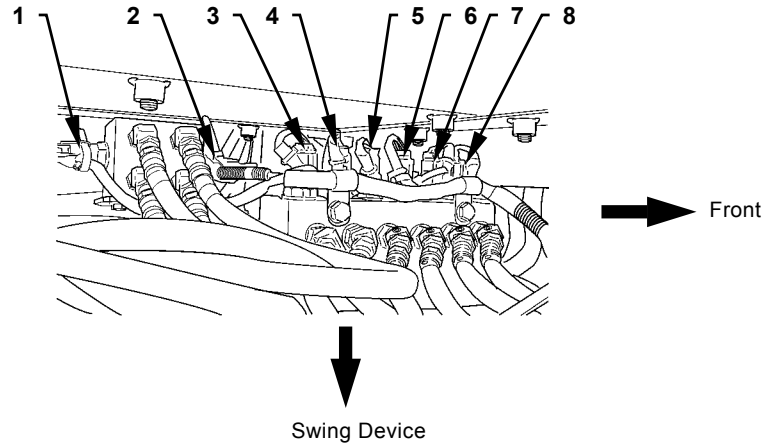

T1JB-01-02-008

### Solenoid Valve Unit

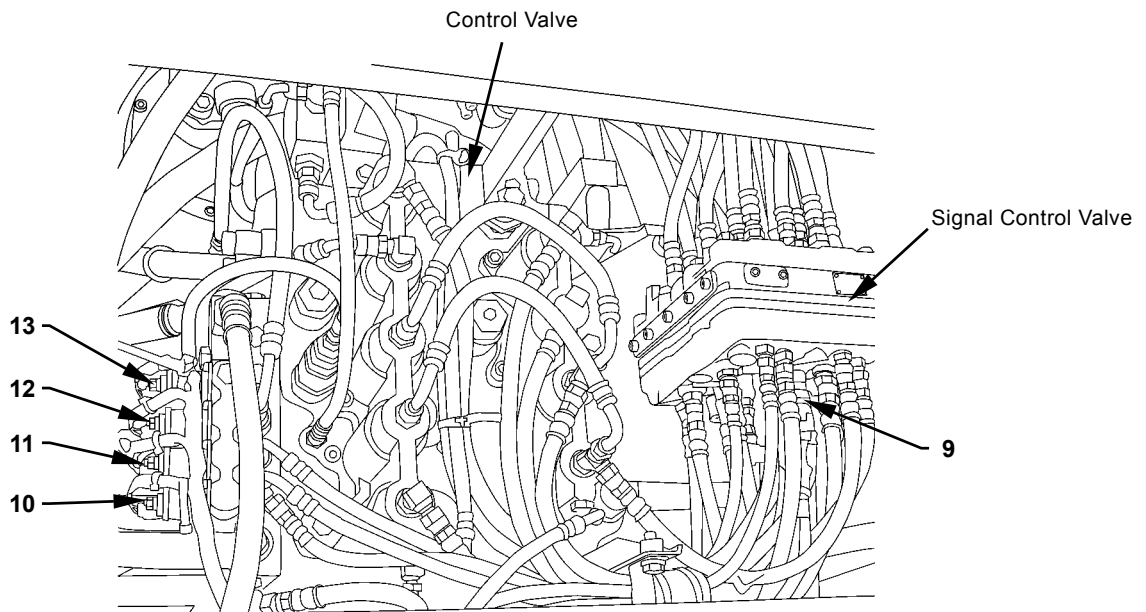

T1J1-01-02-007

- |                                    |                                    |                                  |                               |
|------------------------------------|------------------------------------|----------------------------------|-------------------------------|
| 1 - Pressure Sensor (Travel Right) | 5 - Pressure Sensor (Arm Roll-Out) | 8 - Pressure Sensor (Boom Raise) | 11 - Solenoid Valve Unit (SI) |
| 2 - Pressure Sensor (Travel Left)  | 6 - Pressure Sensor (Arm Roll-In)  | 9 - Pressure Sensor (Swing)      | 12 - Solenoid Valve Unit (SF) |
| 3 - Pressure Sensor (Bucket Cloud) | 7 - Pressure Sensor (Boom Lower)   | 10 - Solenoid Valve Unit (SG)    | 13 - Solenoid Valve Unit (SC) |
| 4 - Pressure Sensor (Bucket Dump)  |                                    |                                  |                               |

# GENERAL / Component Layout

## ENGINE

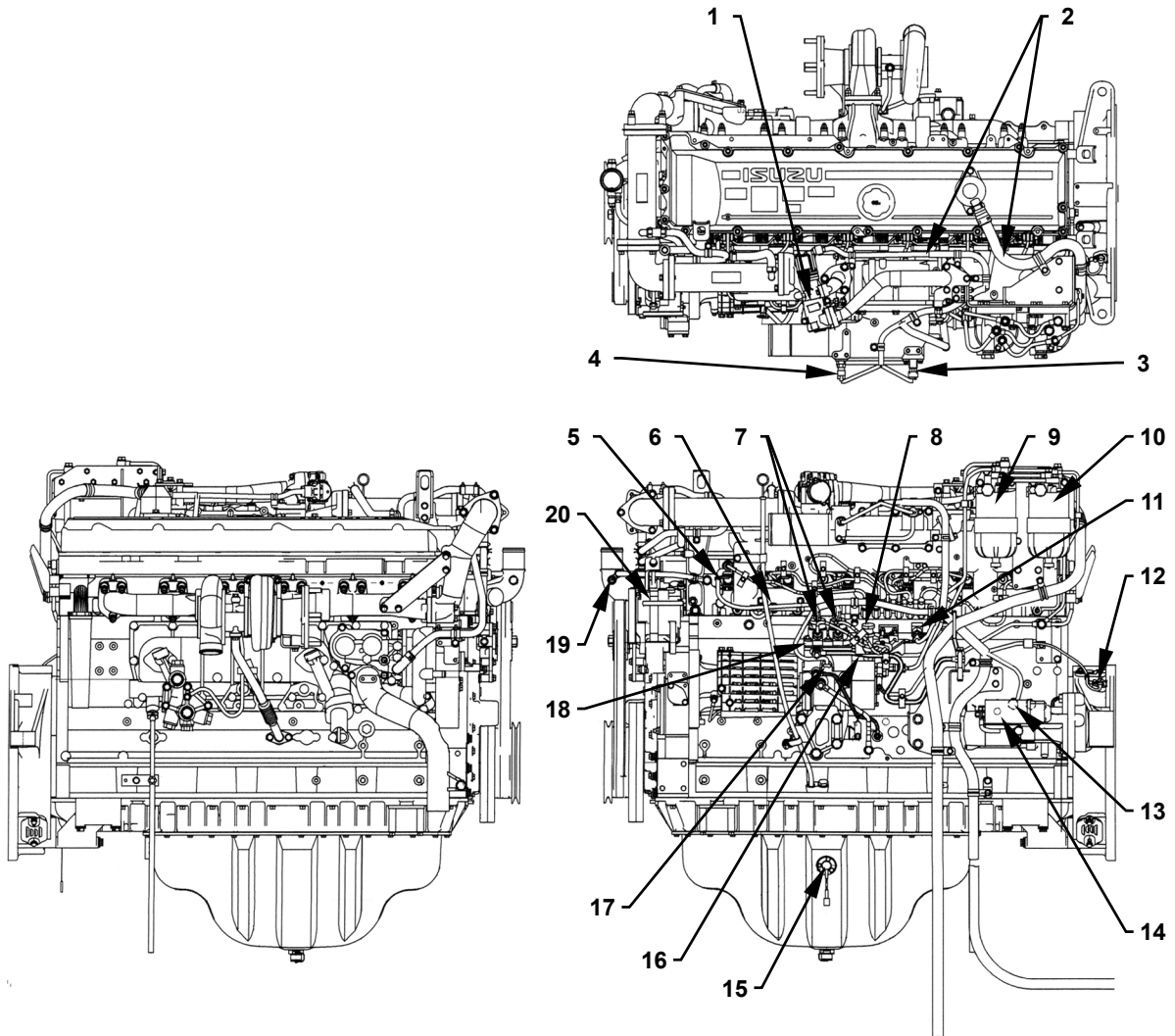

T1J1-01-02-001

- |                                       |                                |                                  |                              |
|---------------------------------------|--------------------------------|----------------------------------|------------------------------|
| 1 - EGR (Exhaust Recirculation) Valve | 6 - Coolant Temperature Sensor | 11 - Common Rail Pressure Sensor | 16 - Fuel Temperature Sensor |
| 2 - Injector Connector                | 7 - Suction Control Valve      | 12 - Crank Revolution Sensor     | 17 - Cam Angle Sensor        |
| 3 - Boost Pressure Sensor             | 8 - Priming Pump               | 13 - Engine Oil Pressure Sensor  | 18 - Supply Pump             |
| 4 - Boost Temperature Sensor          | 9 - Fuel Main Filter           | 14 - Starter                     | 19 - Overheat Sensor         |
| 5 - Glow Plug                         | 10 - Fuel Pre-Filter           | 15 - Engine Oil Level Switch     | 20 - Alternator              |

# GENERAL / Component Layout

## PUMP DEVICE

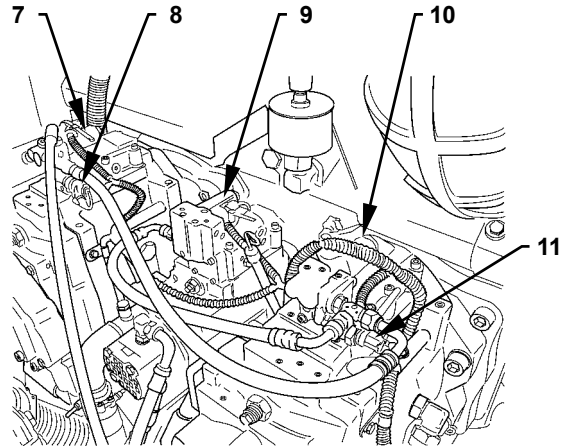
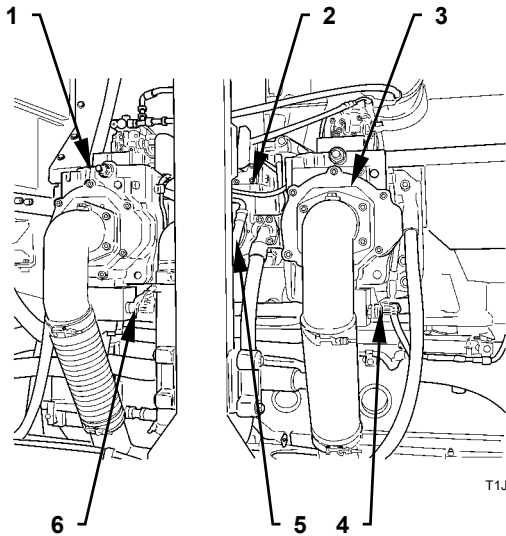

## SWING DEVICE

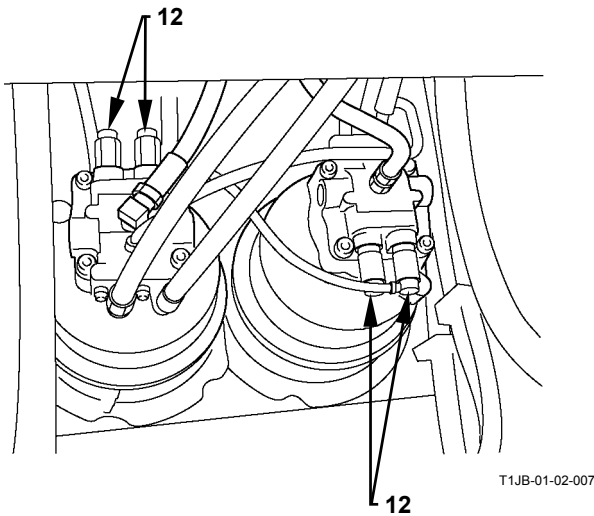

## TRAVEL DEVICE

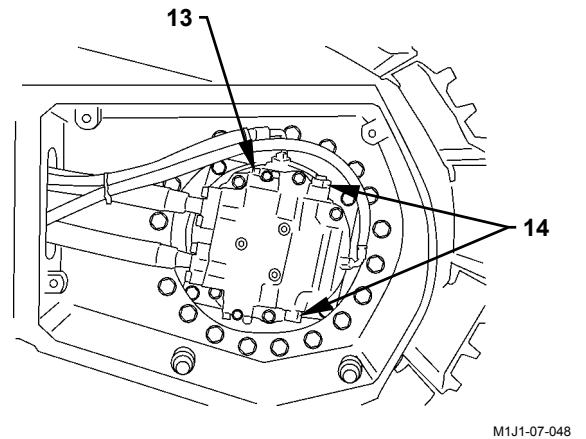

- 1 - Pump 1
- 2 - Fan Pump
- 3 - Pump 2
- 4 - Pump 2 Delivery Pressure Sensor

- 5 - Pilot Pump
- 6 - Pump 1 Delivery Pressure Sensor
- 7 - Pump 1 Control Solenoid Valve
- 8 - Pump 1 Regulator Pressure Sensor

- 9 - Fan Pump Control Solenoid Valve
- 10 - Pump 2 Control Solenoid Valve
- 11 - Pump 2 Regulator Pressure Sensor

- 12 - Swing Relief Valve
- 13 - Counterbalance Valve
- 14 - Travel Relief Valve

# GENERAL / Component Layout

## CONTROL VALVE

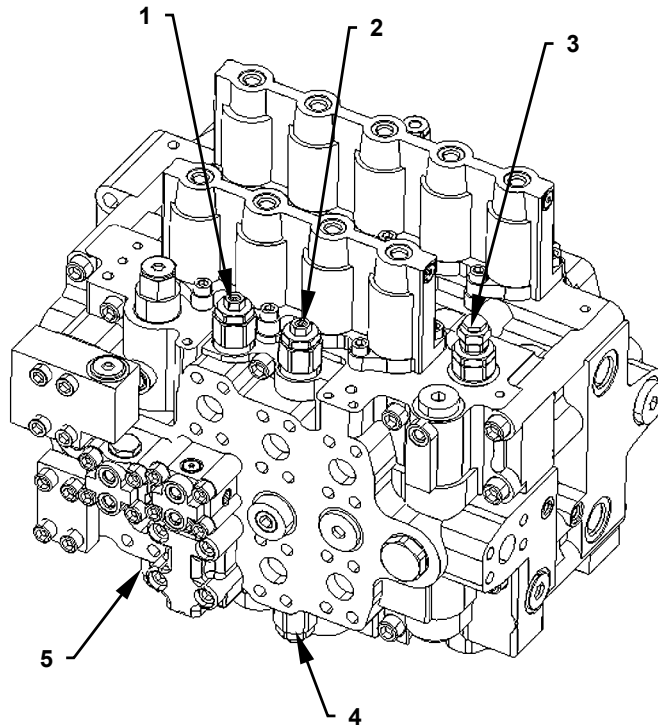

T1JB-03-03-024

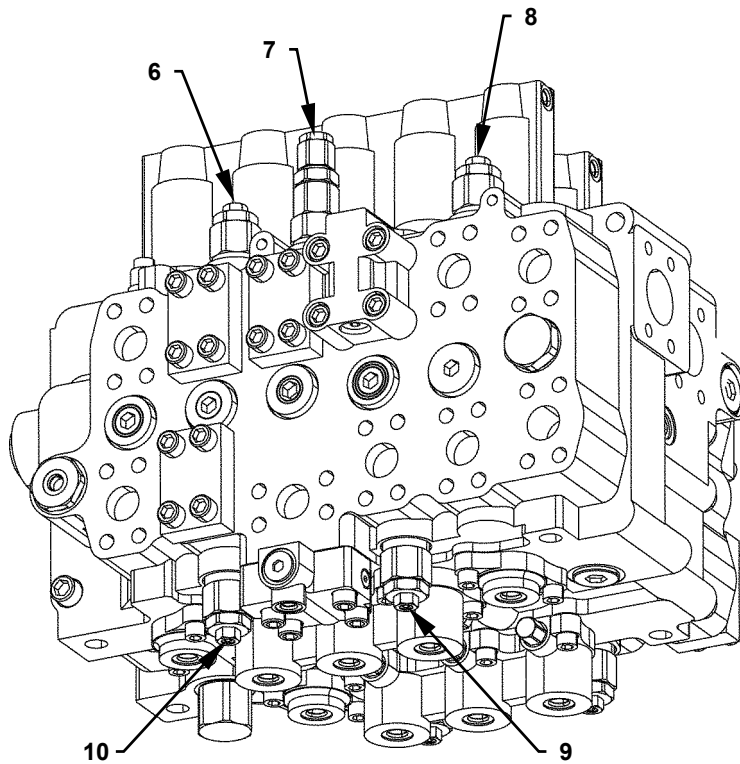

T1J1-03-03-004

- |   |  |  |   |
|---|--|--|---|
| 1 - Overload Relief Valve               | 4 - Overload Relief Valve (Bucket Cloud) | 7 - Overload Relief Valve (Boom Mode)    | 9 - Overload Relief Valve (Arm Roll-In) |
| 2 - Overload Relief Valve (Bucket Dump) | 5 - Overload Relief Valve (Boom Raise)   | 8 - Overload Relief Valve (Arm Roll-Out) | 10 - Overload Relief Valve (Auxiliary)  |
| 3 - Main Relief Valve                   | 6 - Overload Relief Valve (Auxiliary)    |  |   |

**GENERAL / Component Layout**

---

(Blank)

## GENERAL / Component Specifications

---

### ENGINE

Manufacturer .....	ISUZU
Model .....	AH-6W41XYA-02
Type .....	Diesel, 4-Cycle, Water-cooled, Inline, Direct Injection
Cyl. No.- Bore × Stroke .....	6-147 mm×154 mm (5.79 in×6.06 in)
Piston Displacement .....	15681 cm <sup>3</sup> (957 in <sup>3</sup> )
Rated Output .....	345±7 kW/1800 min <sup>-1</sup> (469±10 PS/ 1800 rpm)
Compression Ratio .....	16.0
Dry Weight .....	1153 kg (2542 lb)
Firing Order .....	1-5-3-6-2-4
Rotation Direction .....	Clockwise (Viewed from fan side)

### COOLING SYSTEM

Cooling Fan .....	Dia. 1120 mm (44.1 in), 6 Blades Draw-in Type
Thermostat .....	Cracking Temperature at Atmospheric Pressure: 83 °C (181 °F) Full Open (Stroke: 10 mm or more) Temperature: 95 °C (203 °F)
Water Pump .....	Centrifugal Gear Driven Type

### LUBRICATION SYSTEM

Lubrication Pump Type .....	Gear Pump
Oil Filter .....	Combined System of Full Flow and Bypass Type
Oil Cooler .....	Water Cooled Integral Type

### STARTING SYSTEM

Motor .....	Reduction Type
Voltage / Output .....	24 V / 7 kW (9.5 PS)

### PREHEAT SYSTEM

Preheating Method .....	Glow Plug (QOS II Type)
-------------------------	-------------------------

### ENGINE STOP SYSTEM

Stop Method .....	Fuel Shut-Off
-------------------	---------------



## GENERAL / Component Specifications

---

### ALTERNATOR

Type.....AC Type (With IC Regulator)  
Voltage / Output.....24 V / 50 A

### SUPERCHARGING SYSTEM

Type.....Exhaust-Turbocharger Type TD08H

### FUEL SYSTEM

Type..... Common Rail 6HD Type  
Governor ..... Electrical Centrifugal All Speed Control  
Injection Nozzle ..... Electrical Multi-Hole Type

### EXHAUST RECIRCURATION SYSTEM

EGR Valve .....Electrical Valve  
Cooling System .....Water Cooled, Diameter 80x300 mm (3.2x11.8 in)x2 pcs

### PERFORMANCE (at New engine)

Lubricant Consumption .....Less than 100 mL/h (0.03 US gal/h) at 1800 min<sup>-1</sup> (rpm)  
Fuel Consumption Ratio.....Less than 214±13.6 g/kW/h (157±10 g/PS/h) at 1800 min<sup>-1</sup>  
(rpm) (without Fan)  
Injection Timing .....0 ° before T.D.C.  
Maximum Output Torque .....1980 N·m (202 kgf·m) at approx. 1500 min<sup>-1</sup> (rpm)  
Compression Pressure.....2.94 MPa (30 kgf/cm<sup>2</sup>, 427 psi)  
Valve Clearance (Inlet / Exhaust).....0.4 / 0.4 mm (when cool)  
No Load Speed .....Slow: 900±25 min<sup>-1</sup> (rpm)  
Fast: 1850±30 min<sup>-1</sup> (rpm)

# GENERAL / Component Specifications

## Engine Performance Curve (AH-6WG1XYA-02)

- Test Condition: 1. In conformity with JIS D1005 (Performance Test Method for Diesel Engine Used for Construction Machinery) under standard atmospheric pressure.  
2. Equipped with alternator and without fan.

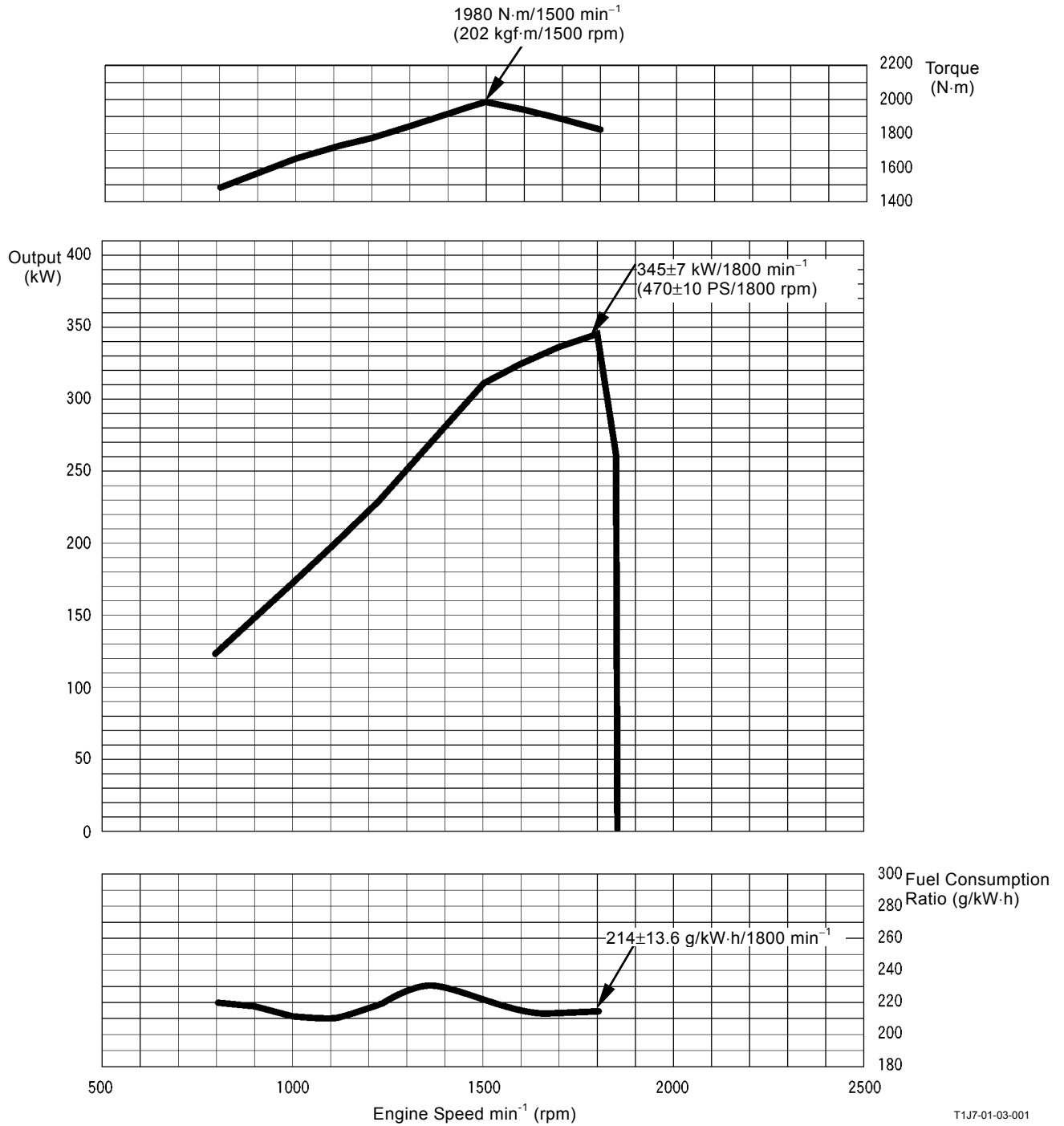

T1J7-01-03-001

## GENERAL / Component Specifications

### ENGINE ACCESSORIES

#### RADIATOR ASSEMBLY

Type..... Radiator/Oil Cooler Parallel, Inter Cooler Tandem Type Assembly  
Weight ..... 400 kg (882 lb)

	Radiator	Oil Cooler
Core Row .....	2	3
Fin Pitch .....	3.5/2P mm	3.5/2P mm
Fin Type.....	ALW-4	CF40-1×3line
Radiating Area.....	103.85 m <sup>2</sup> (1118 ft <sup>2</sup> )	89.01 m <sup>2</sup> (958 ft <sup>2</sup> )
Capacity.....	20.8 L (5.5 US gal)	23.4 L (6.2 US gal)
Air-Tight Test Pressure.....	100 kPa (1.0 kgf/cm <sup>2</sup> , 14 psi)	1 MPa (10 kgf/cm <sup>2</sup> , 287 psi)
Cap Opening Pressure.....	49 kPa (0.5 kgf/cm <sup>2</sup> , 7 psi)	–

	Inter Cooler
Core Row .....	–
Fin Pitch .....	4.0/2P mm
Fin Type.....	10 Hole Pipe
Radiating Area.....	34.07 m <sup>2</sup> (367 ft <sup>2</sup> )
Capacity.....	40 L (10.6 US gal)
Air-Tight Test Pressure.....	–
Cap Opening Pressure.....	–

#### FUEL COOLER

Weight ..... 1.2 kg (2.6 lb)  
Fin Pitch ..... 4.0 mm  
Fin Type..... Wave Fin  
Capacity..... 0.5 L (0.13 US gal)  
Radiating Area..... 1.55 m<sup>2</sup> (16.7 ft<sup>2</sup>)  
Air-Tight Test Pressure..... 1.5 MPa (15 kgf/cm<sup>2</sup>, 218 psi)  
Cap Opening Pressure..... –

#### BATTERY

Type..... 195G51-MF  
Capacity..... 170 Ah (20-Hour Rate)  
Voltage..... 12 V  
Height × Width × Length..... 257×222×508 mm (10×8.7×20 in)  
Weight ..... 41.0 kg (90 lb)× 2

## GENERAL / Component Specifications

---

### HYDRAULIC COMPONENT

#### PUMP DEVICE

Drive Gear Ratio.....Engine: 1, Pump 1 and 2: 53/57  
Engine: 1, Fan Pump: 1  
Engine: 1, Pilot Pump: 32/31

#### MAIN PUMP

Type.....Variable Displacement Swash Plate Tandem Plunger Pump  
Maximum Flow (Theoretical Value).....463 L/min (122 US gpm) ×2

#### FAN PUMP

Type.....Variable Displacement Swash Plate Tandem Plunger Pump  
Maximum Flow (Theoretical Value).....91 L/min (24 US gpm)

#### PILOT PUMP

Model.....HY/ZFS 11/16.8 R  
Type.....Fixed Displacement Type Gear Pump  
Maximum Flow (Theoretical Value).....33.6 L/min (8.88 US gpm)  
HP Mode: 35.3 L/min (9.33 US gpm)

#### CONTROL VALVE

Model.....UH36-200  
Type.....Pilot Pressure Operated Type (4-Spools + 5-Spools)  
Main Relief Set-Pressure.....Normal: 31.9 MPa (325 kgf/cm<sup>2</sup>, 4638 psi) at 340 L/min  
(90 US gpm)  
Power Digging: 34.3 MPa (350 kgf/cm<sup>2</sup>, 4987 psi) at 320  
L/min (84 US gpm)  
Overload Relief Set-Pressure .....35.3 MPa (360 kgf/cm<sup>2</sup>, 5132 psi) at 110 L/min (29 US gpm)  
(Arm, Bucket, Boom, Auxiliary Close)  
27.9 MPa (285 kgf/cm<sup>2</sup>, 4053 psi) at 110 L/min (29 US gpm)  
(Auxiliary Open)

## GENERAL / Component Specifications

---

### SWING DEVICE

Type.....Two-Stage Reduction Planetary Gear  
Reduction Gear Ratio.....21.75

### SWING MOTOR

Model.....M5X130CHB  
Type.....Swash-Plate Type, Fixed Displacement Axial Plunger Motor

### VALVE UNIT

Type.....Non Counterbalance Valve Type  
Relief Set-Pressure .....29.4 MPa (300 kgf/cm<sup>2</sup>, 4274 psi) at 88 L/min (23 US gpm)

### SWING PARKING BRAKE

Type.....Multi-Disc-Wet Negative Type  
Release Pressure .....3.7 MPa (38 kgf/cm<sup>2</sup>, 538 psi)

### TRAVEL DEVICE

Type.....Three-Stage Reduction Planetary Gear  
Reduction Gear Ratio.....74.83

### TRAVEL MOTOR

Type.....Swash-Plate Type Variable Displacement Axial Plunger Motor

### TRAVEL BRAKE VALVE

Type.....Counterbalance Valve Type  
Relief Set Pressure .....36.8 MPa (375 kgf/cm<sup>2</sup>, 5350 psi) @ 120 L/min (32 US gpm)

### TRAVEL PARKING BRAKE

Type.....Multi-Disc-Wet Negative Type  
Cracking Pressure for Release .....1.37 MPa (14 kgf/cm<sup>2</sup>, 199 psi)

### FAN MOTOR

Model.....A2FM63/61W  
Type.....Inclined-Shaft Type, Fixed Displacement Axial Plunger Motor

## GENERAL / Component Specifications

---

### CYLINDER

	Boom	Arm
Rod Diameter .....	130 mm (5.1")	140 mm (5.5")
Cylinder Bore.....	190 mm (7.5")	200 mm (7.9")
Stroke .....	1805 mm (5'11")	2165 mm (7.1")
Fully Retracted Length .....	2600 mm (8'6")	2970 mm (9'9")
Weight .....	550 kg (1213 lb)	800 kg (1764 lb)
	Bucket	Counterweight Removal (Optional)
Rod Diameter .....	130 mm (5.1")	65mm (2.6")
Cylinder Bore.....	180 mm (7.1")	130 mm (5.1")
Stroke .....	1555 mm (5'1")	545 mm (1'9")
Fully Retracted Length .....	2385 mm (7'10")	962 mm (3'2")
Weight .....	550 kg (1213 lb)	84 kg (185 lb)

### FRONT ATTACHMENT PILOT VALVE

Model.....HVP06K-040-101

### TRAVEL PILOT VALVE

Model.....HVP05S-040-101

### AUXILIARY/ COUNTER WEIGHT REMOVAL PILOT VALVE (Optional)

Model.....HVP05M-040-101

### SOLENOID VALVE UNIT

Function.....

- SG : Power Digging Control
- SI : Travel Motor Swash Angle Control
- SF : Boom Flow Rate Control Valve Control
- SC : Boom Mode Selector Control

### PILOT PRESSURE SIGNAL CONTROL VALVE

Function.....

- Shock Reducing (Boom Raise)
- Arm Flow Rate Control Valve Control
- Swing Parking Brake Release
- Flow Combiner Valve Control

### PILOT SHUT-OFF SOLENOID VALVE

Type.....ON/OFF Solenoid Valve

## GENERAL / Component Specifications

---

### OIL COOLER BYPASS CHECK VALVE

Cracking Pressure.....100±50 kPa (1.0±0.5 kgf/cm<sup>2</sup>) @ 40 L/min (10.5 US gpm)

### BYPASS CHECK VALVE

Relief Set Pressure .....350±70 kPa (3.6±0.7 kgf/cm<sup>2</sup>)

## GENERAL / Component Specifications

---

### ELECTRICAL COMPONENT

#### BATTERY RELAY

Voltage / Current ..... 24 V / 100 A

#### GLOW PLUG RELAY

Voltage.....24 V



## GENERAL / Component Specifications

---

### HORN

Voltage / Current .....	24 V·3 A
Sound Pressure.....	110±5 dB (A)

### ILLUMINATION

Specification .....	Work/Boom Light: Halogen 24V, 70 W
	Cab Light: 24 V, 10 W

### AIR CONDITIONER

Refrigerant .....	134 a
Cooling Ability.....	16.7 MJ/h (4000 kcal/h)
Cool Air Volume.....	550 m <sup>3</sup> /h (718 yd <sup>3</sup> /h) or More
Heating Ability.....	21.0 MJ/h (5000 kcal/h) or More
Warm Air Volume.....	400 m <sup>3</sup> /h (523 yd <sup>3</sup> /h) or More
Temperature Adjusting System .....	Electronic Type
Refrigerant Quantity .....	1150±50 g (2.5±0.11 lb)
Compressor Oil Quantity.....	180 <sup>+15</sup> <sub>0</sub> cm <sup>3</sup> (0.047 <sup>+0.004</sup> <sub>0</sub> US gal)





---

---

# SECTION 2 SYSTEM

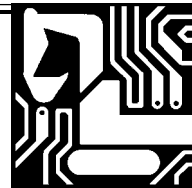

## —CONTENTS—

### Group 1 Controller

Outline .....	T2-1-1
Can: Controller Area Network (Network Provided for Machine) .....	T2-1-2
MC: Main Controller.....	T2-1-3
ECM: Engine Control Module .....	T2-1-12
ICF: Information Controller .....	T2-1-14
Monitor Unit.....	T2-1-16

### Group 2 Control System

Outline .....	T2-2-1
Engine Control.....	T2-2-4
Pump Control .....	T2-2-21
Valve Control .....	T2-2-40
Other Controls .....	T2-2-52

### Group 3 ECM System

Outline .....	T2-3-1
Fuel Injection Control .....	T2-3-2
Fuel Injection Amount Correction Control .....	T2-3-10
Preheating Control .....	T2-3-11
EGR (Exhaust Gas Recirculation) Control.....	T2-3-12
Engine Stop Control.....	T2-3-14

### Group 4 Hydraulic System

Outline .....	T2-4-1
Pilot Circuit.....	T2-4-2
Main Circuit .....	T2-4-14
Counterweight Removal / Installation Circuit (Optional) .....	T2-4-24

### Group 5 Electrical System

Outline .....	T2-5-1
Main Circuit.....	T2-5-2
Electric Power Circuit (Key Switch: OFF).....	T2-5-4
Accessory Circuit .....	T2-5-5
Starting Circuit (Key Switch: START) .....	T2-5-6
Charging Circuit (Key Switch: ON).....	T2-5-10
Surge Voltage Prevention Circuit .....	T2-5-14
Pilot Shut-Off Circuit (Key Switch: ON) ...	T2-5-16
Security Lock Circuit .....	T2-5-18
Engine Stop Circuit (Key Switch: OFF) ...	T2-5-20
Security Horn Circuit.....	T2-5-21
Working Light Circuit.....	T2-5-22
Wiper / Washer Circuit.....	T2-5-24

---

(Blank)

## SYSTEM / Controller

### OUTLINE

The controllers are provided for each control respectively.

Each controller is connected by using CAN (Controller Area Network) in order to display on the monitor unit in cab or the monitoring of machine overall condition including the engine.

- MC : Main Controller
- ECM : Engine Control Module
- ICF : Information Controller
- Monitor Unit

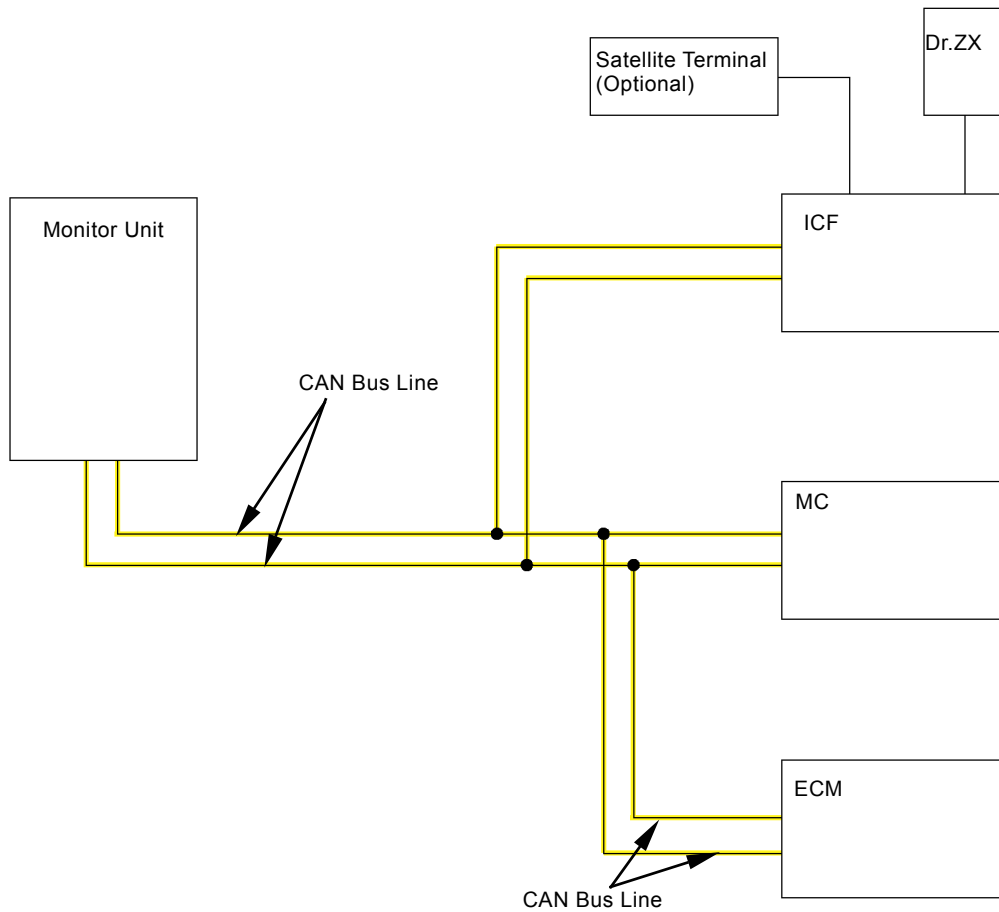

T1J1-02-01-004

 NOTE: CAN (CAN Bus Line)

## SYSTEM / Controller

### CAN: CONTROLLER AREA NETWORK (NETWORK PROVIDED FOR MACHINE)

MC, ECM, ICF and the monitor unit are connected by using CAN bus line and communicate the signal and data each other.

CAN bus line consists of two harnesses, CAN High and CAN Low.

Each controller judges the CAN bus line level due to potential difference between CAN High and CAN Low. Each Controller arranges the CAN bus line level and sends the signal and data to other controllers.

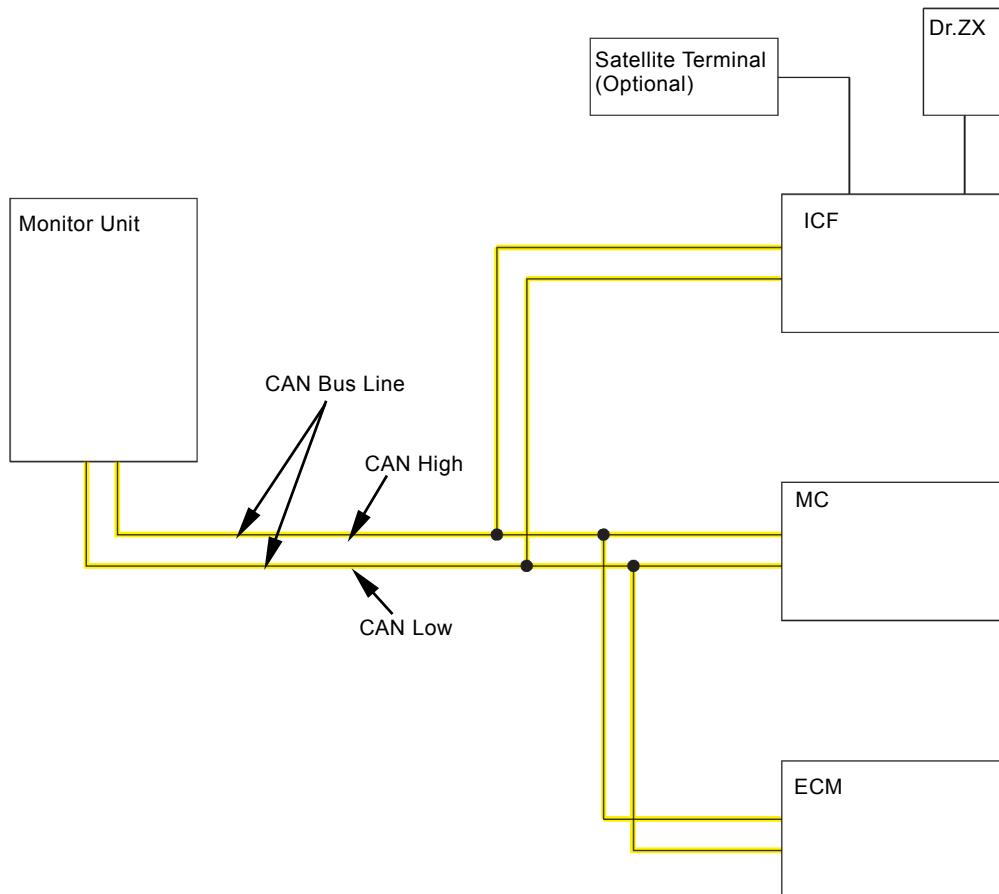

T1V1-02-01-050

## SYSTEM / Controller

---

### MC: MAIN CONTROLLER

#### Function Outline

The signals from engine control dial, sensors and switches are input to MC. Information from ECM, ICF and monitor unit are input to MC by using CAN.

MC processes the input signals in the logic circuit and sends the signal equal to target engine speed to ECM (Engine Control Module) by using CAN communication in order to control the engine.

MC drives the solenoid valve unit and pump control solenoid valve in order to control the pump and valve.

 **NOTE:** As for details on each control, refer to the Control System group / SYSTEM.

MC has the controls as follows.

- Engine Control
  - Engine Control Dial Control
  - ECO Control
  - HP Mode Control
  - Travel Speed Increase Control
  - E Mode Control
  - Auto-Idle Control
  - Attachment Operation Speed Increase Control (Optional)
  - Attachment Operation Speed Decrease Control (Optional)
- Pump Control
  - Pump Flow Rate Control
  - Speed Sensing Control
  - Horsepower Control
  - Relief Flow Rate Reducing Control
  - Swing Horsepower Reducing Control
  - Overheat Prevention Control
  - Attachment Mode Control (Optional)
  - Counterweight Removal and Installation Control (Optional)
  - Fan Pump Flow Rate Control
  - Pump Learning Control
- Valve Control (Solenoid Valve Unit)
  - Pressure Increase Selection Control When Traveling
  - Power Digging Control
  - Auto-Power Lift Control
  - Travel Motor Swash Angle Control
  - Boom Mode Selector Control
  - Boom Flow Rate Control Valve Control
- Other Control
  - Work Mode Control
  - Rear Monitoring Display Selection Control (Optional)
  - Level Check Control
  - Auto Lubrication Control (Optional.)
  - Travel Alarm Control (Optional)
  - Overload Alarm Control (Optional)



## SYSTEM / Controller

---

- Engine Control
  - C Engine Control Dial Control, ECO Control  
Controls the engine speed according to the rotation angle of engine control dial. (Engine Control Dial Control)  
Reduces the engine speed to  $1600 \text{ min}^{-1}$  in 1 second in order to reduce fuel consumption and noise level when all the control levers are in neutral. (ECO Control)
  - HP Mode Control  
Slightly increases digging power such as arm roll-in operation while excavating deeply.
  - Travel Speed Increase Control  
Increases the engine speed and travels faster during travel single operation.
  - E Mode Control  
Reduces the target engine speed to  $1580 \text{ min}^{-1}$  in maximum in order to reduce fuel consumption.
  - Auto-Idle Control  
Reduces the engine speed to  $1030 \text{ min}^{-1}$  in 3.5 seconds when all the control levers are in neutral with the auto-idle switch ON. Therefore, fuel consumption and noise level can be reduced.
  - Attachment Operation Speed Increase Control (Optional)  
Set attachment operation speed (breaker) to increase (+) with Dr. ZX. When operating the attachment, engine speed increases to the attachment operating speed set by Dr. ZX.
  - Attachment Operation Speed Decrease Control (Optional)  
Set attachment operation speed (breaker) to decrease (-) with Dr. ZX. When the attachment mode is selected, engine speed decreases to the attachment operating speed set by Dr. ZX.

# SYSTEM / Controller

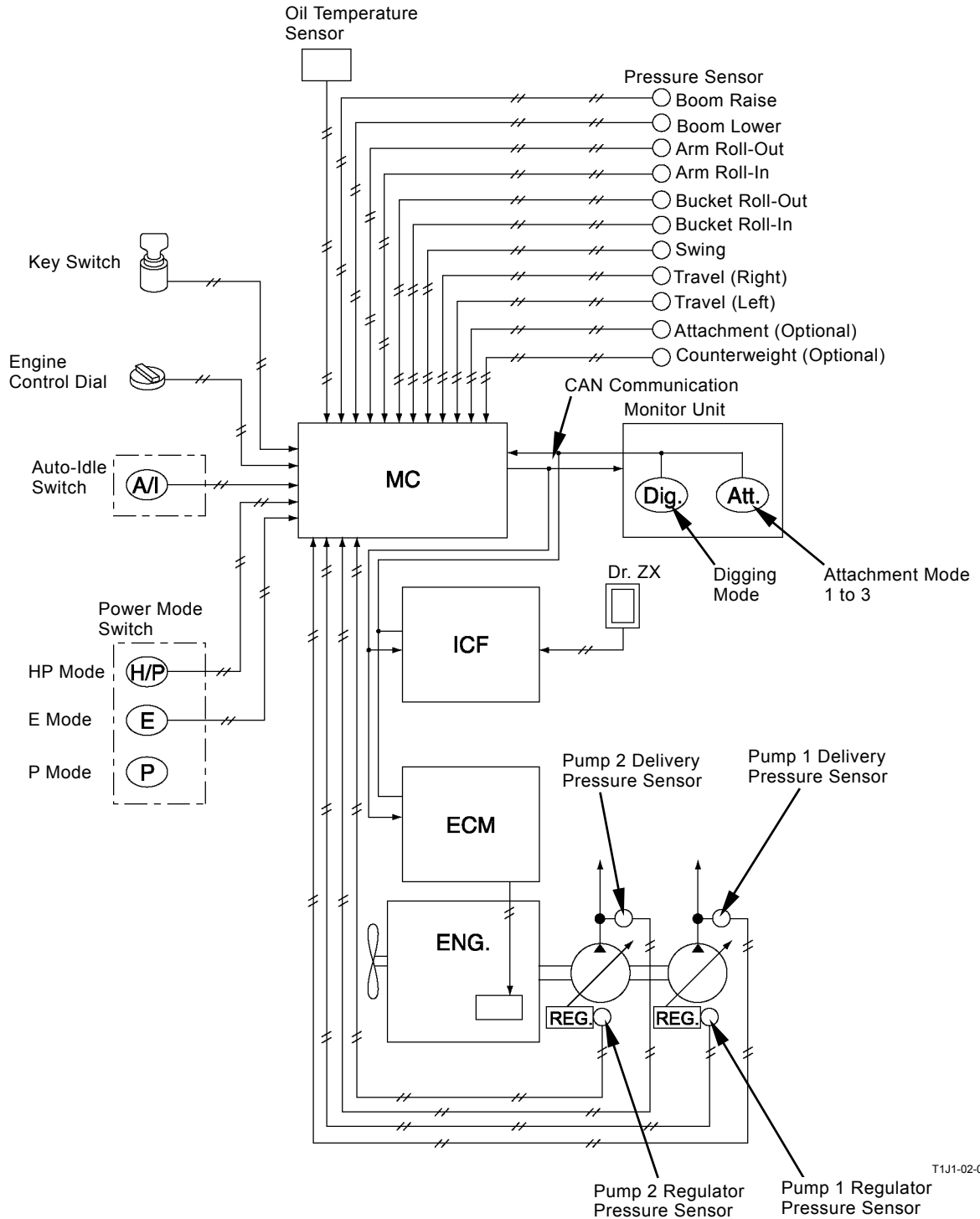

T1J1-02-02-021

## SYSTEM / Controller

---

- PUMP CONTROL

- Pump Flow Rate Control  
Delivers oil required for the actuator according to the control lever stroke from the main pump.
- Speed Sensing Control  
Controls the pump flow rate in response to engine speed changes due to variations in load so that the engine output can be utilized more efficiently. (Engine stall is prevented when the machine operates under adverse conditions such as operating at high altitude.)
- Horsepower Control  
Controls delivery flow rate of each main pump and uses engine power effectively so that sum of pump torques divided to two main pumps and fan pump does not exceed the engine output torque.
- Relief Flow Rate Reducing Control  
Controls hydraulic energy loss and prevents hydraulic oil temperature from rising. (Flow Rate Reducing Control (Relief Cut Off))
- Swing Horsepower Reducing Control  
Decreases delivery flow rate of main pump 2 including the swing circuit, increases delivery flow rate of main pump 1 and uses the engine power effectively when the swing control lever is operated and the pressure sensor (swing) detects swing pilot pressure.
- Overheat Prevention Control  
Reduces maximum flow rate and suction torque of the main pump, reduces the engine load and prevents overheating when temperature of coolant or hydraulic oil increases beyond the specified level.
- Attachment Mode Control (Optional)  
Limits the upper of maximum flow rate of pump 2 and controls the appropriate flow rate for the attachment when operating the attachment with the work mode in attachment mode.
- Counterweight Removal and Installation Control (Optional)  
Applies back-pressure to the main relief valve, increases main relief pressure and the hoist / lower power improves. Or, Controls pump delivery flow rate and makes fine operation easy.
- Fan Pump Flow Rate Control  
Controls delivery flow rate of the fan pump according to boost temperature (intake air temperature passing by the intercooler), coolant temperature, hydraulic oil temperature and intake air temperature), and controls fan rotation speed in order to make temperature of oil cooler, radiator and intercooler appropriate.
- Pump Learning Control  
Detects pressure, which is necessary to pump control, when the pump control solenoid valve is activated.

# SYSTEM / Controller

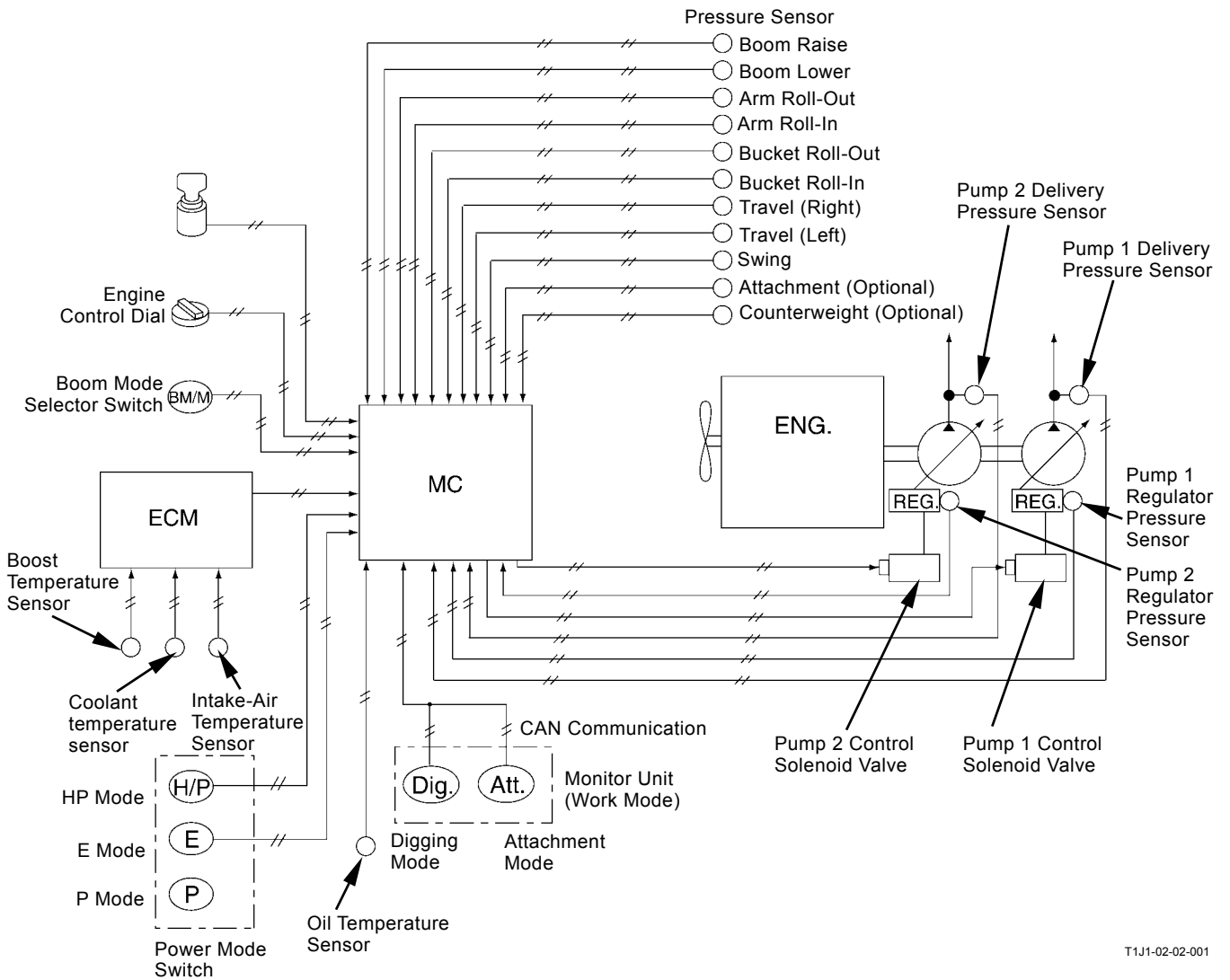

T1J1-02-02-001

## SYSTEM / Controller

---

- Valve Control (Solenoid Valve Unit)
  - Pressure Increase Selection Control When Traveling, Power Digging Control  
MC drives solenoid valve unit (SG) temporarily, supplies back-pressure to the main relief valve and increases main relief pressure.
  - Auto-Power Lift Control  
When operating boom raise, MC drives solenoid valve unit (SG) temporarily, supplies back-pressure to the main relief valve and increases main relief pressure.
  - Travel Motor Swash Angle Control  
When shifting the travel mode switch, MC drives solenoid valve unit (SI) and selects the travel mode.
  - Boom Mode Selector Control  
MC drives solenoid valve unit (SC) and selects the overload relief control valve. Therefore, as relief set-pressure of the overload relief valve at the boom lower side decreases, vibration of the machine is reduced during digging and grading work.
  - Boom Flow Rate Control Valve Control  
During combined operation of boom lower and arm or boom lower and bucket, MC drives solenoid valve unit (SF).  
Therefore, the switch valve of boom flow rate control valve is shifted and oil through the boom cylinder is restricted.  
When the boom is lowered due to own weight with the regenerative circuit and pressure oil from the pump is used for other actuator, operating speed of actuator increases.

# SYSTEM / Controller

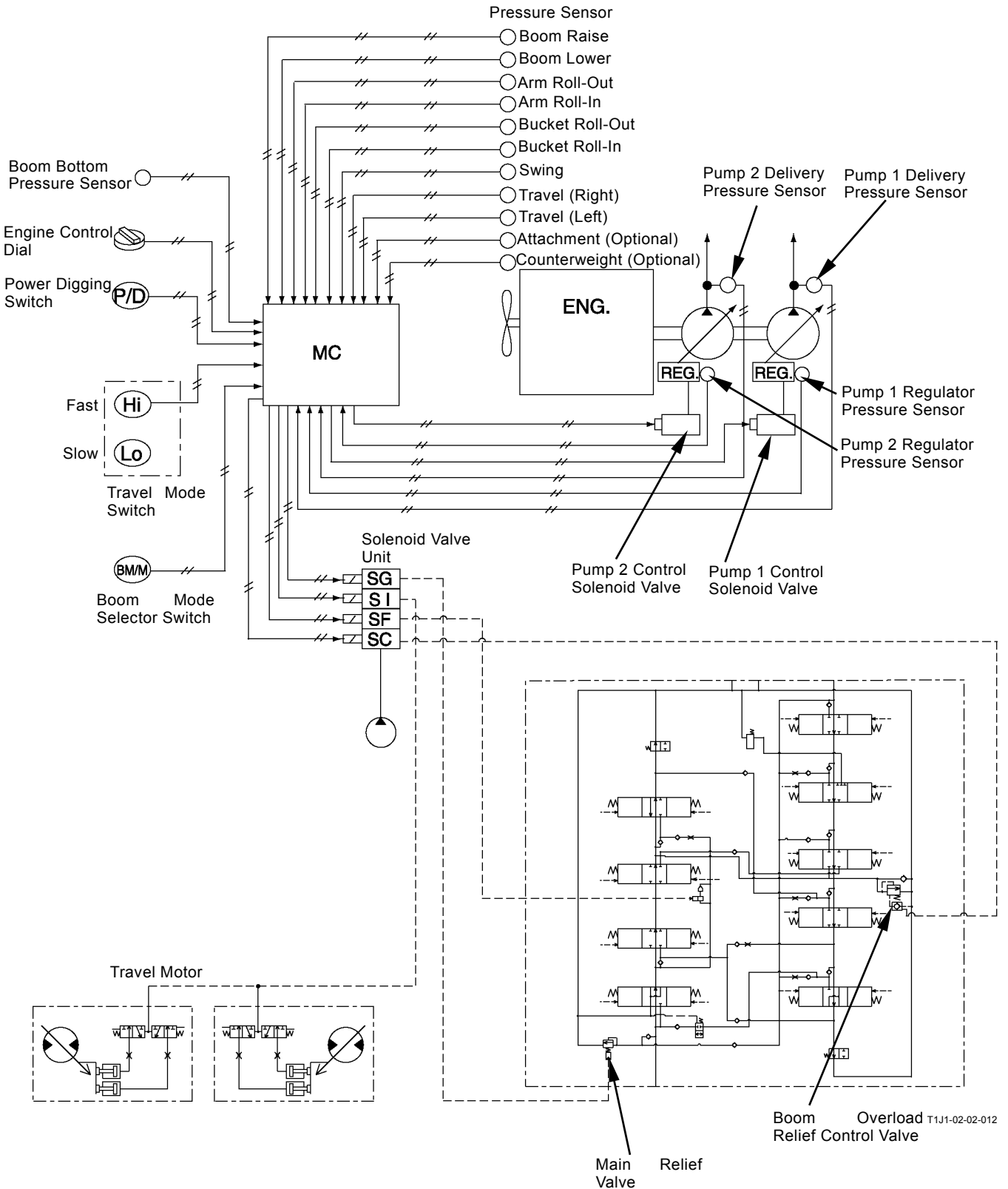

## SYSTEM / Controller

---

- OTHER CONTROL

- Work Mode Control

- The work mode control consists of two modes, digging and attachment.

- The mode can be selected by using the monitor unit.

- Rear Monitoring Display Selection Control

- Switches the screen of monitor unit to that of the back-screen.

- Level Check Control

- Checks levels of coolant and engine oil when starting the work. This result is displayed on the monitor unit.

- Auto Lubrication Control (Optional)

- Controls the auto lubrication system correctly.

- Travel Alarm Control (Optional)

- Sounds the buzzer while traveling.

- Overload Alarm Control (Optional)

- Sounds the buzzer and indicates the warning of overload while overloaded operation of boom raise including lifting work.

# SYSTEM / Controller

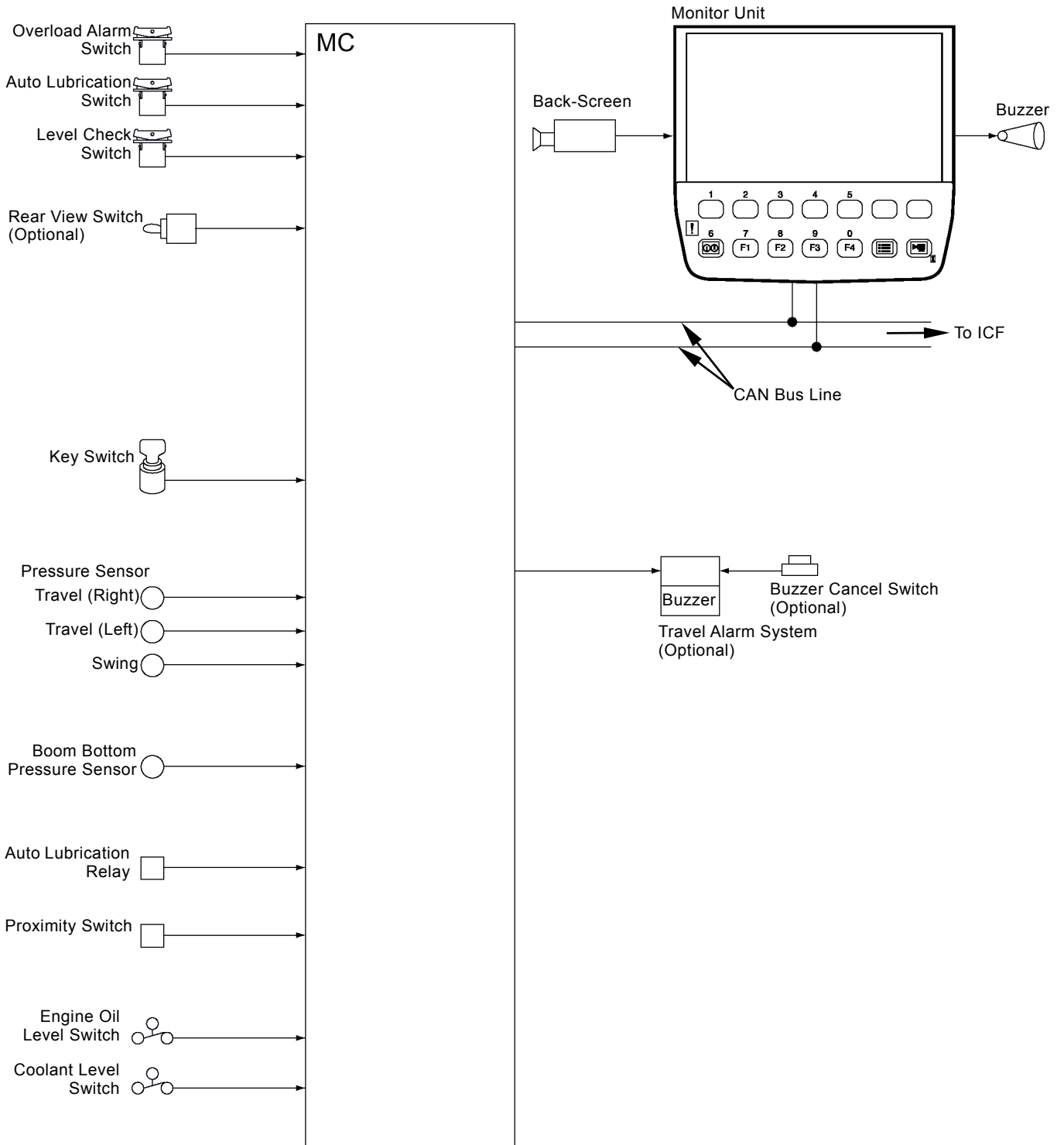

T1J1-02-01-001



## SYSTEM / Controller

---

### ECM: ENGINE CONTROL MODULE

#### Function Outline

ECM (Engine Control Module) receives the signals from sensors and MC

ECM processes and drives the two-way valve, suction control valve and EGR (Exhaust Gas Recirculation) motor in order to control the supply pump, injector pump and EGR valve.

ECM has the controls as follows.

- Fuel Injection Control  
ECM detects the engine operating condition according to the signals from each sensor and MC and controls the fuel injection.
- Fuel Injection Amount Correction  
ECM adjusts fuel injection amount according to the signal of atmospheric pressure sensor.
- Preheating Control  
ECM controls time for continuity of electrical current for the glow plug according to coolant temperature and improves the starting of engine.
- EGR Control  
ECM decides EGR gas amount according to engine speed, fuel flow rate, coolant temperature, atmospheric pressure and intake-air temperature. ECM opens EGR valve and re-circulates exhaust gas, amount of which is equal to EGR gas amount, in the intake manifold. EGR gas is combined with intake-air so that combustion temperature is lowered and NOx is reduced.
- Engine Stop Control  
When the emergency stop switch is turned to the ON position, ECM stops the fuel injection of injector and stops the engine.

 **NOTE:** As for details on each control, refer to the ECM System group / SYSTEM.

# SYSTEM / Controller

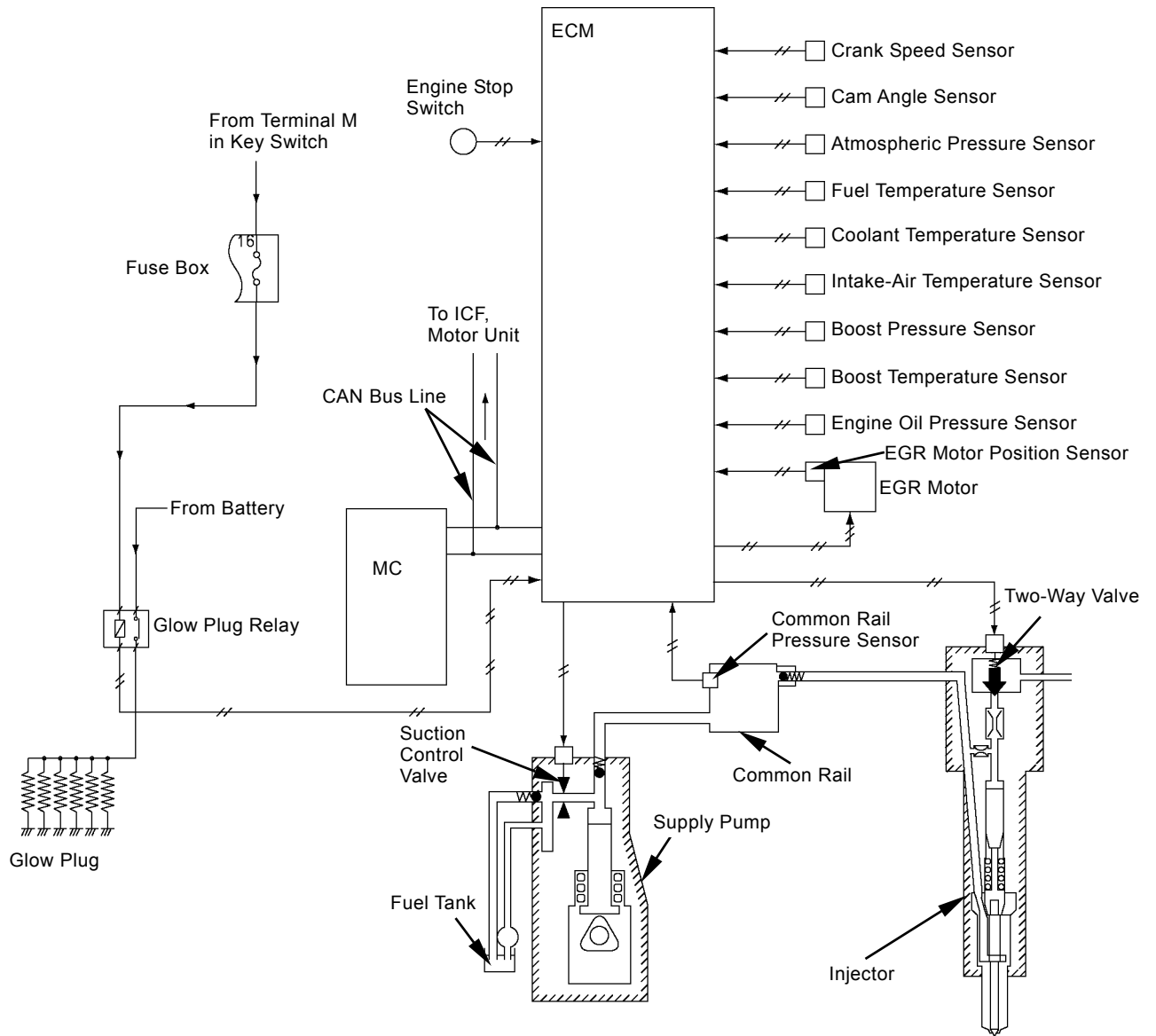

T1J1-02-01-002

## SYSTEM / Controller

---

### ICF: INFORMATION CONTROLLER

#### Function Outline

- Operating Hours Management  
The built-in clock is provided for ICF.  
ICF sends data of built-in clock to the monitor unit by using CAN bus line.
- Alarm, Fault Code Memory  
ICF memorizes the alarm and fault code from each controller by using CAN bus line in the time series.  
The memorized alarm and fault code are sent to the center server by the satellite terminal (optional).  
Engine oil pressure alarm and overheat alarm are sent to the center server whenever these occur.  
Other alarm and fault code are sent to the center server once a day.
- Fault Code Display  
ICF displays the fault code sent from each controller by using CAN bus line on Dr. ZX.
- Maintenance History  
When the maintenance key is pushed on the monitor unit, time is recorded.
- Daily Report Data Making  
ICF records operating hours, fuel level and fuel amount of use during daily operation, and makes the daily report data.  
The daily report data can be sent to the center server by using the satellite terminal (optional).
- Frequency Distribution Data Making  
ICF makes the frequency distribution data every 100 hours.  
The frequency distribution data can be sent to the center server by using the satellite terminal (optional).
- Cumulative Operating Hours Record  
ICF records all hours when the machine is operated.  
The cumulative operating hours can be downloaded to Dr. ZX.
- Mail Data Making (Optional)  
ICF records the mails sent from the monitor unit and sends them to the center server by the satellite terminal.

# SYSTEM / Controller

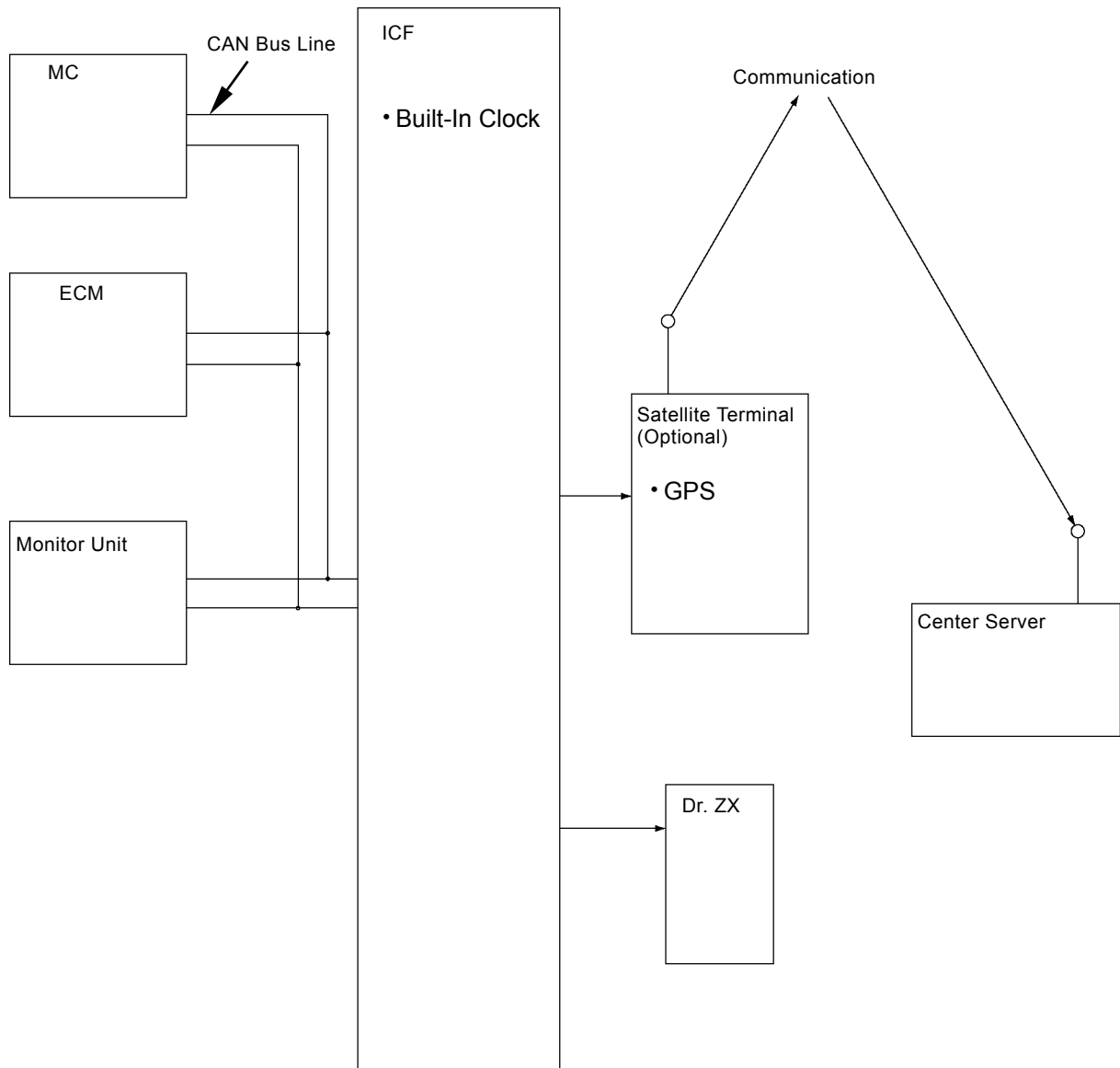

T1V1-02-01-049

# SYSTEM / Controller

## OUTLINE

### Function Outline Primary Screen

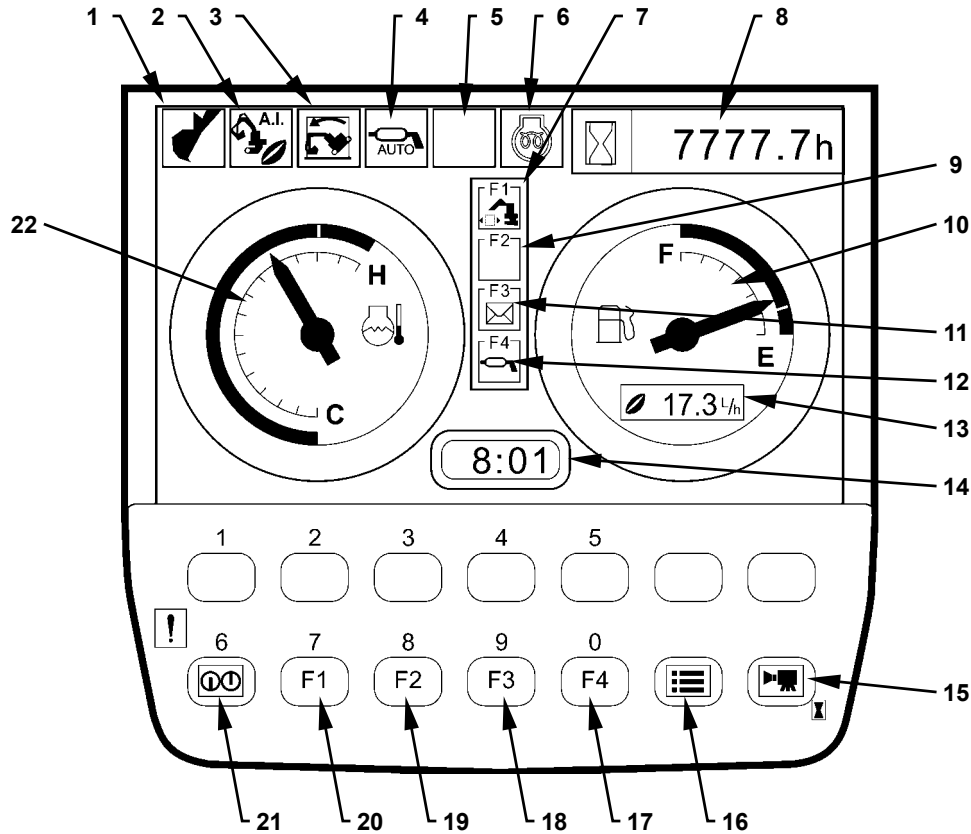

T1J1-02-01-003

- |   |  |                             |                                |
|---|--|-----------------------------|--------------------------------|
| 1 - Work Mode Display                   | 7 - Work Mode Display                    | 13 - Fuel Consumption Gauge | 18 - Mail Selection (Optional) |
| 2 - Auto-Idle Display                   | 8 - Hour Meter                           | 14 - Clock                  | 19 - Auxiliary Selection       |
| 3 - Overload Alarm Display (Optional)   | 9 - Auxiliary                            | 15 - Back-Screen Selection  | 20 - Work Mode Selection       |
| 4 - Auto Lubrication Display (Optional) | 10 - Fuel Gauge                          | 16 - Menu                   | 21 - Return to Primary Screen  |
| 5 - Auxiliary                           | 11 - Mail Display (Optional)             | 17 - Auxiliary Selection    | 22 - Coolant Temperature Gauge |
| 6 - Glow Display                        | 12 - Auto Lubrication Display (Optional) |                             |                                |

## SYSTEM / Controller

- **Display of Meters**  
Data to be displayed on each meter are received from other controllers (MC, ICF and ECM) by using CAN, and are displayed on the monitor unit.

- **Work Mode Display**  
The attachments being used are displayed according to the signals received from MC by using CAN.

### Digging Mode



### Attachment Mode Breaker



T1V1-05-01-108

T1J7-02-01-001

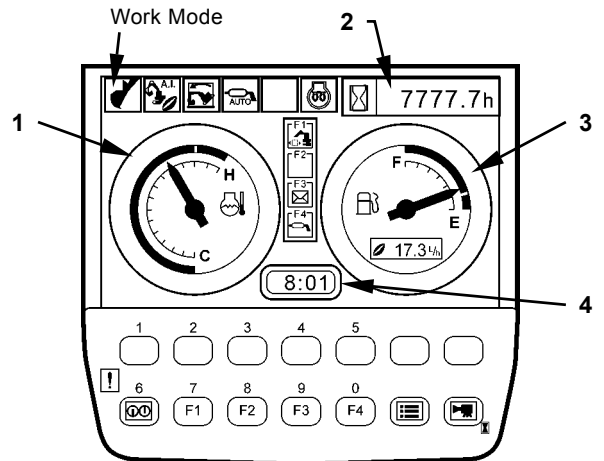

M1J1-01-003

- |                         |                |
|-------------------------|----------------|
| 1 - Coolant Temperature | 3 - Fuel Gauge |
| 2 - Hour Meter          | 4 - Clock      |

## SYSTEM / Controller

- Auto-Idle Display(1)  
When turning the auto-idle switch ON in the switch panel, the monitor displays the auto-idle.  
When the key is turned ON with the auto-idle switch ON, auto-idle display (1) blinks for 10 seconds.
- Overload Alarm Display (2) (Optional)  
MC detects suspended load according to the signal from the bottom pressure sensor in boom cylinder.  
When overload is detected, the monitor unit displays the alarm and sounds the buzzer according to the signal received from MC by using CAN bus line.  
(Refer to T2-1-34.) (Refer to the Control System group / SYSTEM.)
- Auto Lubrication Display (3)  
When the auto lubrication switch (optional) is turned ON, the auto lubrication is displayed according to the signal received from MC by using CAN bus line.
- Glow Display (4)  
While ECM is supplying current to the glow plug, the data is displayed according to the signal from ECM.  
(Refer to the ECM System group / SYSTEM.)
- Fuel Consumption Gauge Display (5)  
Fuel consumption is displayed according to the signal from ECM, which is received through MC by using CAN.

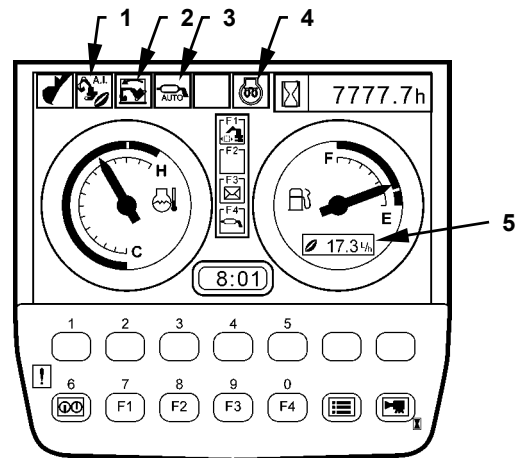

M1J1-01-003

## SYSTEM / Controller

- Fuel Sensor Error Display**  
 When the fuel sensor is faulty or if the harness between fuel sensor and monitor unit is broken, the data is displayed on the fuel gauge.

- Coolant Temperature Sensor Error Display**  
 When the coolant temperature sensor is faulty or if the harness between coolant temperature sensor and monitor unit is broken, the data is displayed on the coolant temperature gauge.

Coolant Temperature Sensor Error Display
Fuel Sensor Error Display

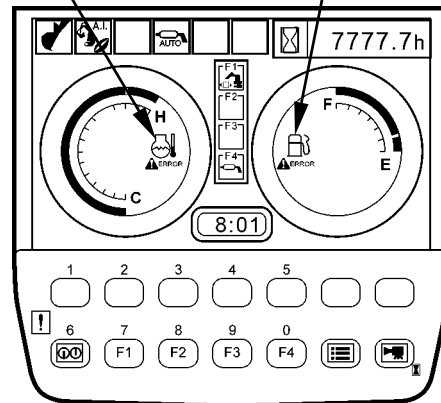

M1J1-01-010

- Alarm and Remedy Displays against Alarm**  
 Alarm marks are displayed on the lower part of screen according to the alarm signals received from each controller by using CAN. The remedy for each alarm is displayed by key operation.

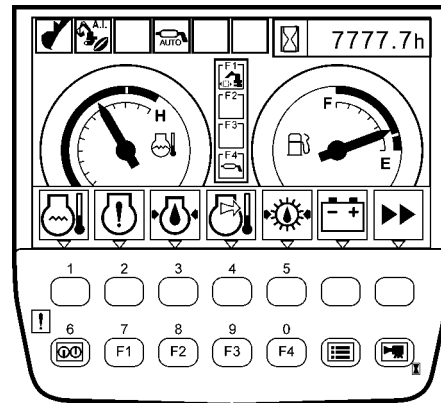

Alarm Display

M1J1-01-008

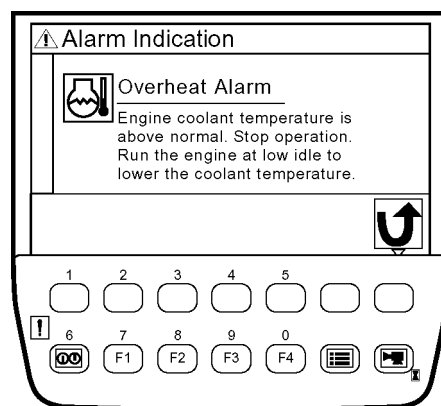

Remedy Display against Alarm

T1V5-05-01-013



## SYSTEM / Controller

- Troubleshooting

This screen displays fault codes according to the signals received from ICF by using CAN.

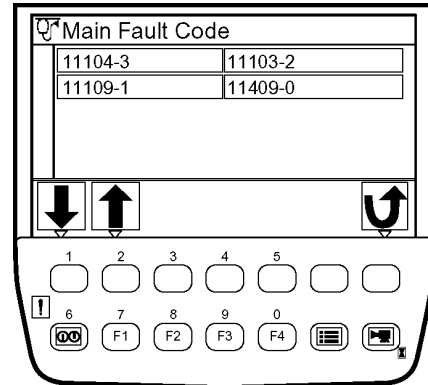

Fault Code Display

T1V5-05-01-097

- Controller Version

This screen displays the version of controller.

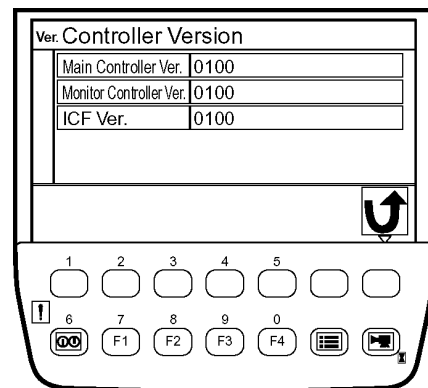

Controller Version Display

T1V5-05-01-122

- Monitoring

This screen displays temperature and pressure data received from each controller by using CAN.

By key operation, the displayed data is hold.

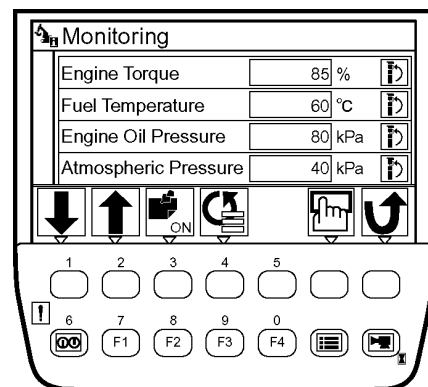

Monitoring Screen

T1V5-05-01-087

- Operating Conditions

This screen displays machine hour, fuel usage and fuel consumption rate registered by the monitor unit.

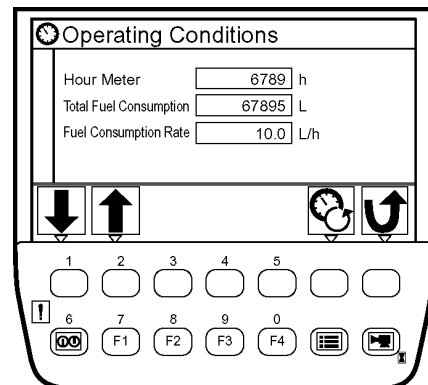

Operating Condition Screen

T1V5-05-01-025

## SYSTEM / Controller

- Pump 2 Flow Rate Adjustment**  
 (Only machines equipped with optional parts)  
 When using the attachments, fine adjust flow rate of pump 2 by keys 1 and 2 operation.  
 (Adjusting range: -50 to 50 L/min)  
 The signals from the monitoring unit are sent to MC by using CAN.  
 MC adjusts flow rate of pump 2 while controlling pump 2 control solenoid valve. (Refer to Attachment Mode Control in the Control Systems group / SYSTEM.)

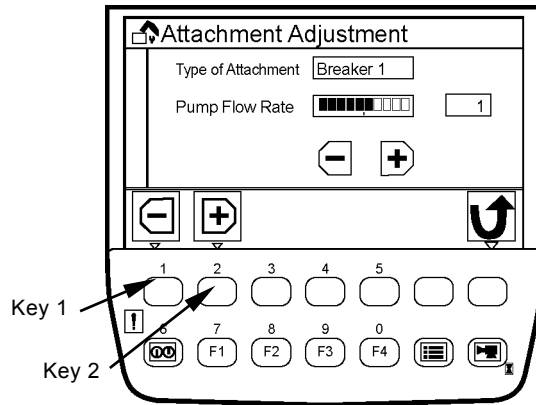

When using Breaker 1

M1J5-01-014

- Attachment Selection**  
 (Only machines equipped with optional parts)  
 On this screen, select digging mode and attachment mode set by Dr. ZX.

**NOTE:** In attachment mode, the following four modes are set at the time of shipping from the factory.

- 1 - Digging
- 2 - Breaker 1
- 3 - Breaker 2
- 4 - Breaker 3
- 5 - Breaker 4

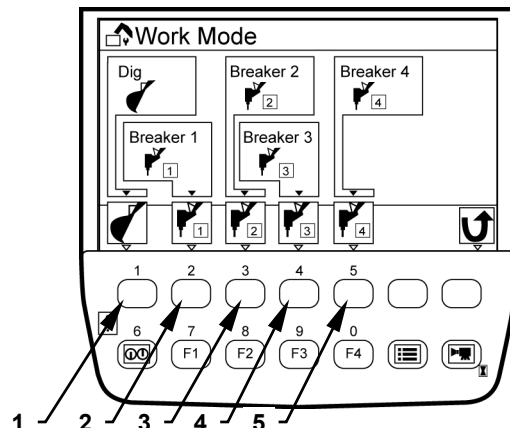

Attachment Selection Screen

T1J7-02-01-005

## SYSTEM / Controller

- Back Monitor Settings

By key operation, image display ON and OFF of Auto-Control for switching image of the back monitor while traveling pilot time and display format on the screen of the rear view camera can be set.

**IMPORTANT:** the rear view camera is set in mirror image mode. Therefore, if image display is set as mirror image, normal image is displayed on the screen of monitor unit.  
If image display is set as normal image, mirror image is displayed on the screen of monitor unit.

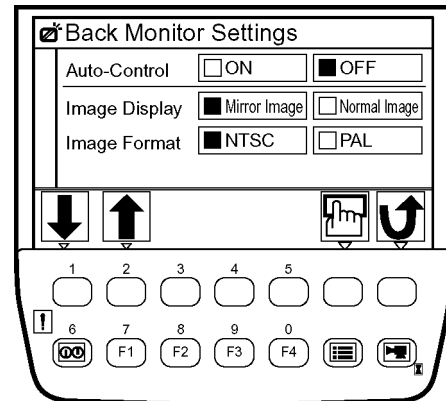

Back Monitor Setting Screen

T1V5-05-01-134

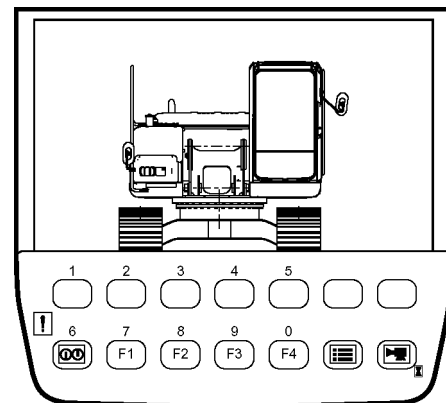

Normal Image Screen

T1V1-05-01-126

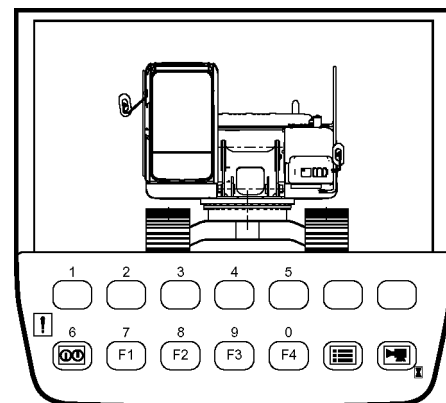

Mirror Image Screen

T1V1-05-01-127

## SYSTEM / Controller

- Maintenance Settings

This screen displays the hour meter reading at replacement time and the remaining hours until the next replacement.

As the items to be replaced are displayed in a list, record performed replacement by selecting an item from the list.

- Interval ON/OFF Settings

Set change interval for each item to be replaced.

- Items included in Maintenance Settings

Engine Oil  
 Engine Oil Filter  
 Hydraulic Oil  
 Hydraulic Oil Pilot Filter  
 Hydraulic Oil Full-Flow Filter  
 Pump Transmission Oil  
 Travel Device Oil  
 Swing Device Oil  
 Swing Bearing Grease  
 Air Cleaner Filter  
 Engine/Air Conditioner V-belt  
 Fuel Filter  
 Air Conditioner Filter

- Language Settings

Select a language to be used in screens from among preset languages, according to work environment.

- Mail

(Optional Function)

Send requests such as requests of forwarding (1), service maintenance (2), fuel replenishment (3) and general (4) in the mail switch screen.

Contents of mails are registered in ICF, and are sent to the central server by a satellite terminal.

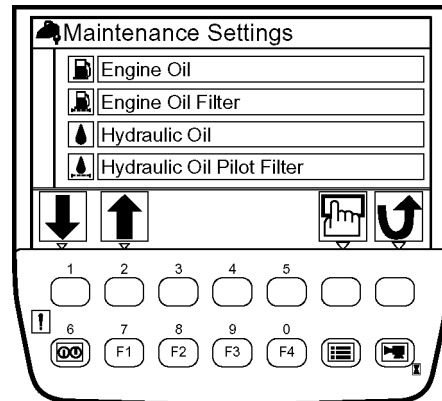

Maintenance Setting Screen

T1V5-05-01-049

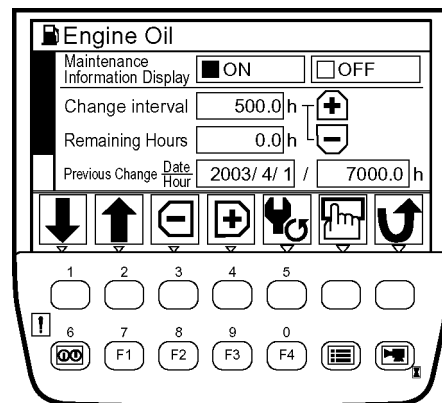

Interval ON/OFF Setting Screen

T1V5-05-01-052

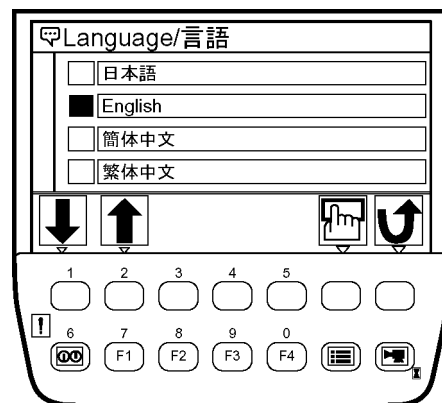

Language Setting Screen

T1V1-05-01-137

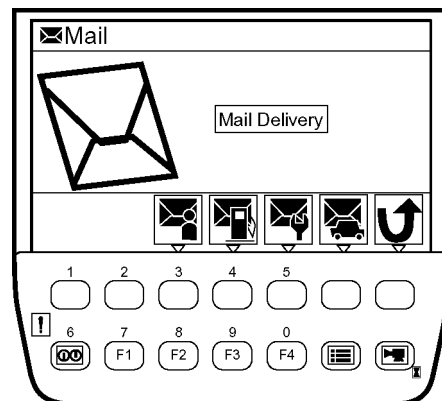

Mail Switch Screen

T1V5-05-01-037

## SYSTEM / Controller

- Overload Alarm  
(Only machines equipped with optional parts)

**IMPORTANT:** When using overload alarm, make overload alarm available by using Dr. ZX.

MC detects suspended load according to the signal from the bottom pressure sensor in boom cylinder. When overload is detected, the monitor unit displays the alarm and sounds the buzzer according to the signal received from MC by using CAN bus line. If overload of the suspended load is dissolved, the alarm message disappears and the buzzer stops ringing. (Refer to the Control System group / SYSTEM.)

 **NOTE:** Even if the work is done while displaying a screen except the primary screen, when an overload condition is reached, the screen of monitor unit is switched to the primary screen, an alarm message is displayed, and a buzzer is rung. Even after the overload alarm is dissolved, the monitor unit keeps on displaying the primary screen without returning to the screen while the work is done.

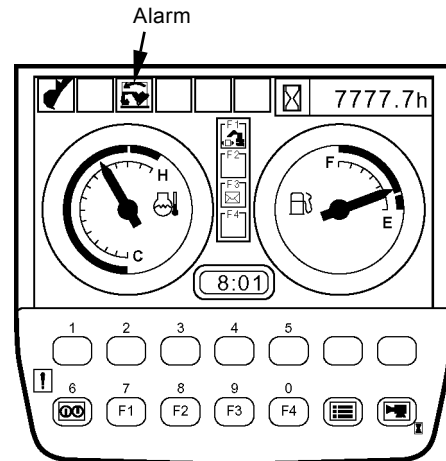

Primary Screen

T1V1-05-01-128

Overload Alarm Switch (Optional)

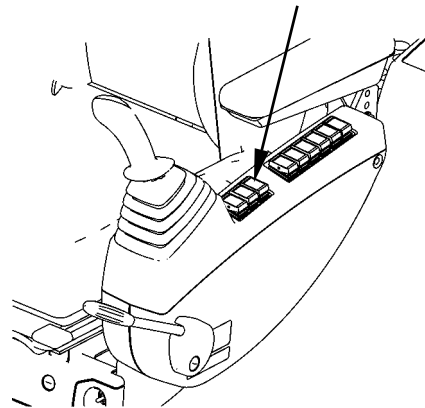

M1J1-03-001

# SYSTEM / Control System

## OUTLINE

MC (Main Controller) is used to control the machine operations. The signals from engine control dial, various sensors and switches are sent to MC and processed in the logic circuit.

MC sends the signals equivalent to the target engine speed to ECM (Engine Control Module) by using CAN communication in order to control the engine.

(Refer to ECM System / SYSTEM.) MC drives the solenoid valve unit and pump control solenoid valve in order to control the pump and valve.

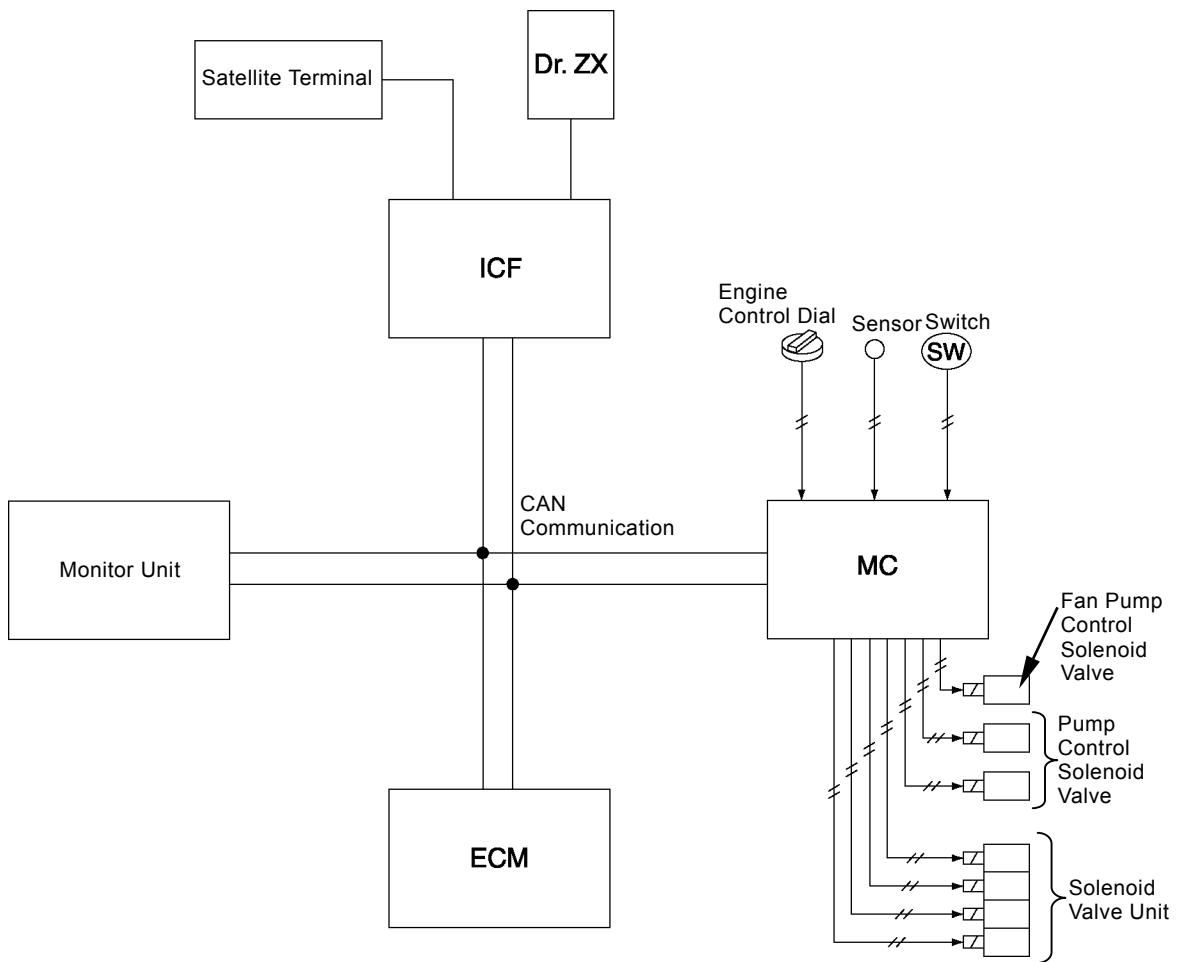

T1J1-02-02-032

## SYSTEM / Control System

Input Signal	Output		
• Engine Control Dial		→	MC
• Pump 1 Regulator Pressure Sensor		→	
• Pump 2 Regulator Pressure Sensor		→	
• Pump 1 Delivery Pressure Sensor		→	
• Pump 2 Delivery Pressure Sensor		→	
• Pressure Sensor (Boom Raise)		→	
• Pressure Sensor (Boom Lower)		→	
• Pressure Sensor (Arm Roll-Out)		→	
• Pressure Sensor (Arm Roll-In)		→	
• Pressure Sensor (Bucket Roll-Out)		→	
• Pressure Sensor (Bucket Roll-In)		→	
• Pressure Sensor (Swing)		→	
• Pressure Sensor (Travel)		→	
• Pressure Sensor (Left Travel)		→	
• Pressure Sensor (Attachment) (Optional)		→	
• Pressure Sensor (Counterweight) (Optional)		→	
• Oil Temperature Sensor		→	
• Auto-Idle Switch		→	
• Power Digging Switch		→	
• Power Mode Switch (HP/E/P)		→	
• Travel Mode Switch (Fast/ Slow)		→	
• Learning Switch		→	
• Pilot Shut-Off Switch		→	
• Boom Mode Selector Switch		→	
• Boom Bottom Pressure Sensor		→	
• Key Switch		→	
• Rear View Switch (Optional)		→	
• Overload Alarm Switch (Optional)		→	
• Auto Lubrication Control Switch (Optional)		→	
• Proximity Switch (Optional)		→	
• Engine Oil Level Switch		→	
• Coolant Level Switch		→	
•		→	
CAN Communication			
• Crank Speed Sensor	E C M	←	Target Engine Speed
• Cam Angle Sensor		←	Actual Engine Speed
• Coolant Temperature Sensor		→	Coolant Temperature
• Boost Temperature Sensor		→	Boost Temperature
• Intake-Air Temperature Sensor		→	Intake-Air Temperature
• Work Mode Switch (From Monitor Unit) (Digging/Attachment)		→	
		→	
			Engine Control
			Engine Control Dial Control
			ECO Control
			HP Mode Control
			Travel Speed Increase Control
			E Mode Control
			Auto-Idle Control
			Attachment Operation Speed Increase Control (Optional)
			Attachment Operation Speed Decrease Control (Optional)
			Pump Control
			Pump Flow Rate Control
			Speed Sensing Control
			Horsepower Control
			Relief Flow Rate Reducing Control
			Swing Hosepower Reducing Control
			Overheat Prevention Control
			Attachment Mode Control (Optional)
			Counterweight Removal and Installation Control (Optional)
			Fan Pump Flow Rate Control
			Pump Learning Control
			Valve Control (Solenoid Valve Unit)
			Pressure Increase Selection Control When Traveling
			Power Digging Control
			Auto-Power Lift Control
			Travel Motor Swash Angle Control
			Boom Mode Selector Control
			Boom Flow Rate Control Valve Control
			Other Control
			Work Mode Control
			Rear Monitoring Display Selection Control
			Level Check Control
			Auto Lubrication Control (Optional)
			Travel Alarm Control (Optional)
			Overload Alarm Control (Optional)

**NOTE:** (Optional): This control is for only the machine with optional parts equipped.

## **SYSTEM / Control System**

---

(Blank)



## SYSTEM / Control System

---

### ENGINE CONTROL

The engine control consists of the following functions.

- Engine Control Dial Control
- ECO Control
- HP Mode Control
- Travel Speed Increase Control
- E Mode Control
- Auto-Idle Control
- Attachment Operation Speed Increase Control (Optional)
- Attachment Operation Speed Decrease Control (Optional)

 *NOTE: (Optional): This control is for only the machine with optional parts equipped.*

# SYSTEM / Control System

## Engine Control System Layout

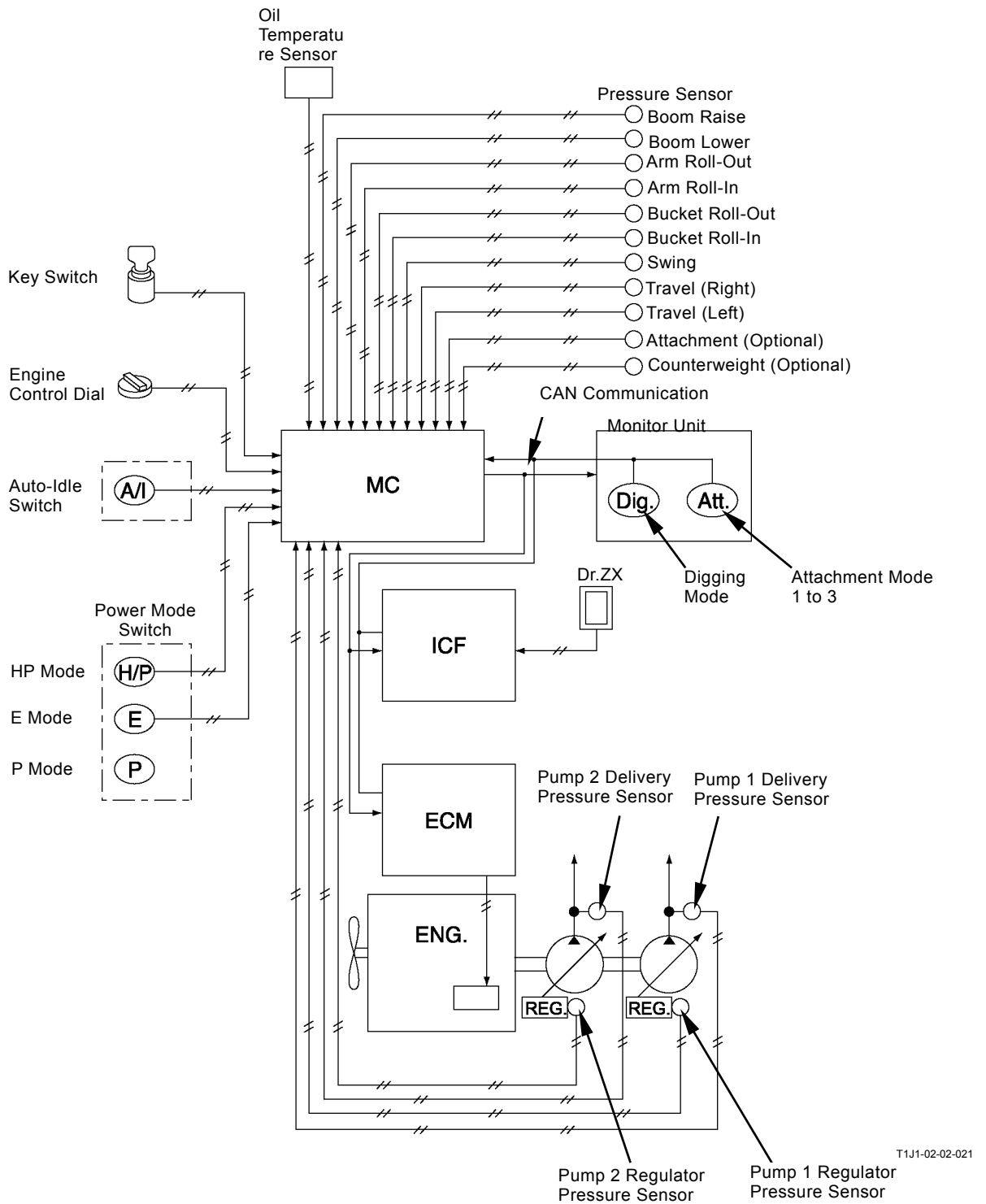

## SYSTEM / Control System

### Engine Control Dial Control

Purpose: Controls the engine speed according to the rotation angle of engine control dial. (Engine control dial control)

Reduces the engine speed to  $1600 \text{ min}^{-1}$  in order to reduce fuel consumption and noise level when all the control levers are in neutral. (ECO control)

Operation:

1. MC sends the signals equivalent to target engine speed to ECM by using CAN communication according to rotation angle of the engine control dial.
2. ECM controls the engine speed according to the signal received by using CAN communication.
3. When the engine control dial is beyond  $1600 \text{ min}^{-1}$  and all the control levers are turned to the neutral position (all pressure sensors: OFF), MC changes the signal to send to ECM as  $1600 \text{ min}^{-1}$  after one second.
4. ECM reduces the engine speed to  $1600 \text{ min}^{-1}$ .

 NOTE: When the engine speed set by the engine control dial is slower than  $1600 \text{ min}^{-1}$ , the engine speed does not change as this speed is slower than the engine speed in ECO control.

*This control is done regardless of whether the auto-idle control is done or not.*

*The fast idle speed (P mode engine speed) of engine can be corrected by Dr. EX.*

 NOTE: The control (ECO control) in operation steps 3, 4 is deactivated by Dr. ZX temporarily or permanently.

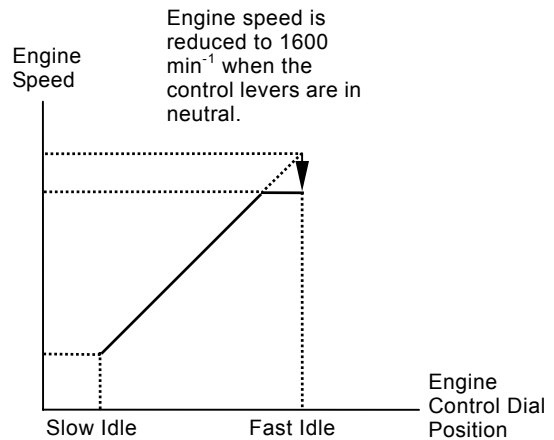

 NOTE: MC sends the target engine speed to ECM every  $10 \text{ ms}$  ( $0.01 \text{ second}$ ). MC changes the data to send to ECM according to the status.

# SYSTEM / Control System

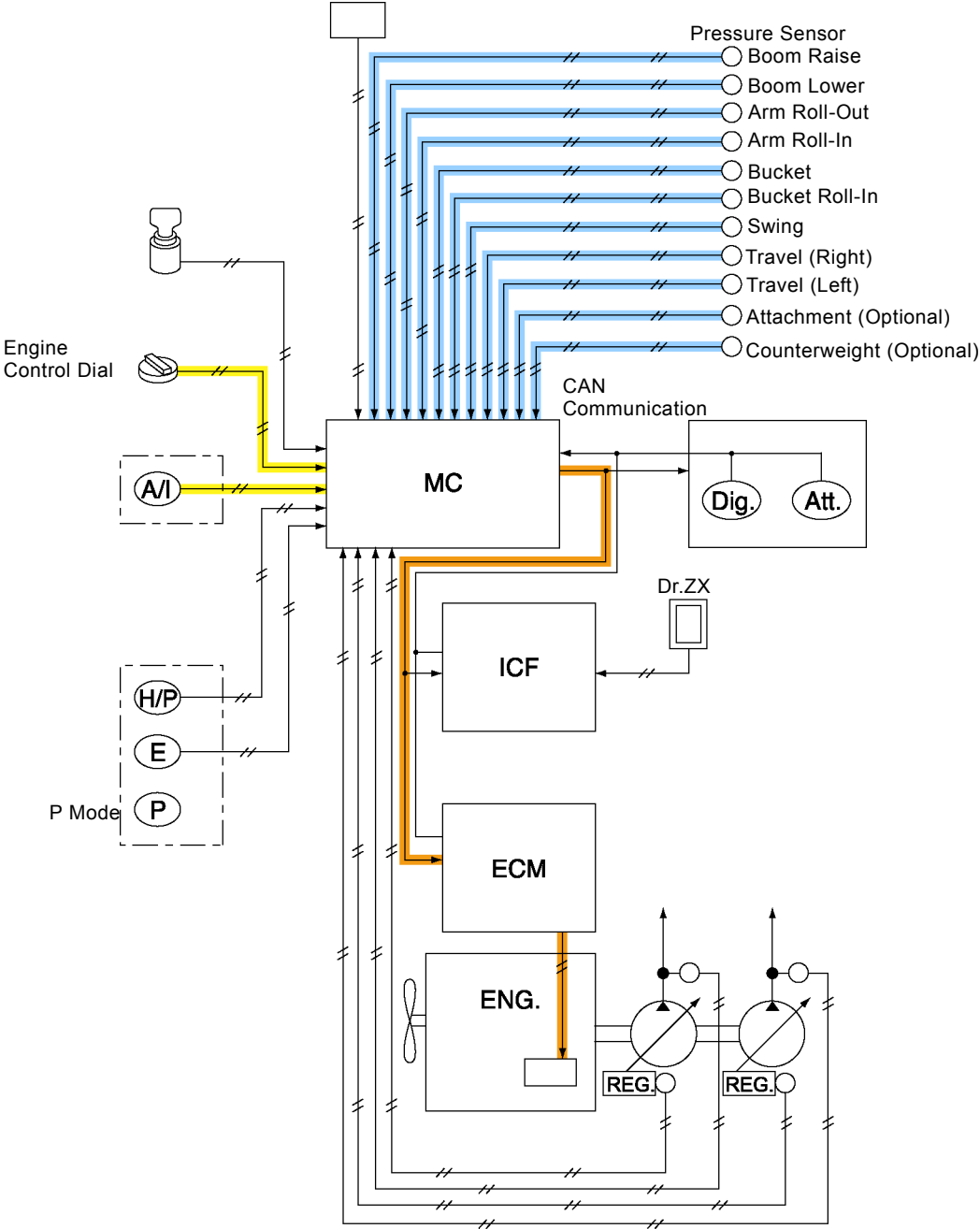

T1J1-02-02-022

## SYSTEM / Control System

### HP Mode Control

Purpose: Slightly increases digging power such as arm roll-in operation while excavating deeply.

#### Operation:

1. When the power mode switch is in the HP mode position and all the following conditions exist, MC sends the signals equivalent to the target engine speed to ECM by using CAN communication.
2. ECM slightly increases the engine speed set by the engine control dial.

#### Condition:

- Engine Control Dial: Set at  $1020 \text{ min}^{-1}$  or faster.
- Boom Raise or Arm Roll-In Operation: Operated
- Average Delivery Pressure of Pumps 1 and 2: High

 **NOTE:** HP mode control is deactivated by Dr. ZX temporarily or permanently. When HP mode is selected with HP mode deactivated, the engine speed can become  $1800 \text{ min}^{-1}$  by using the engine control dial.

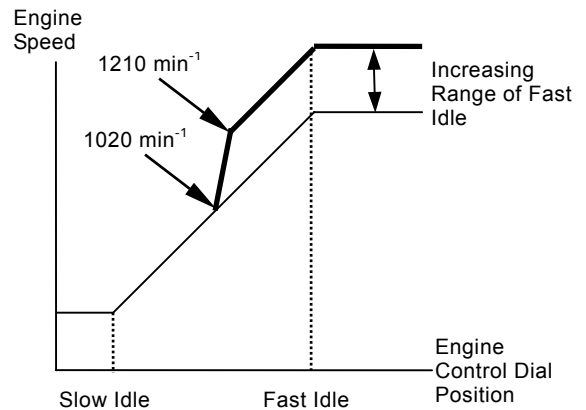

# SYSTEM / Control System

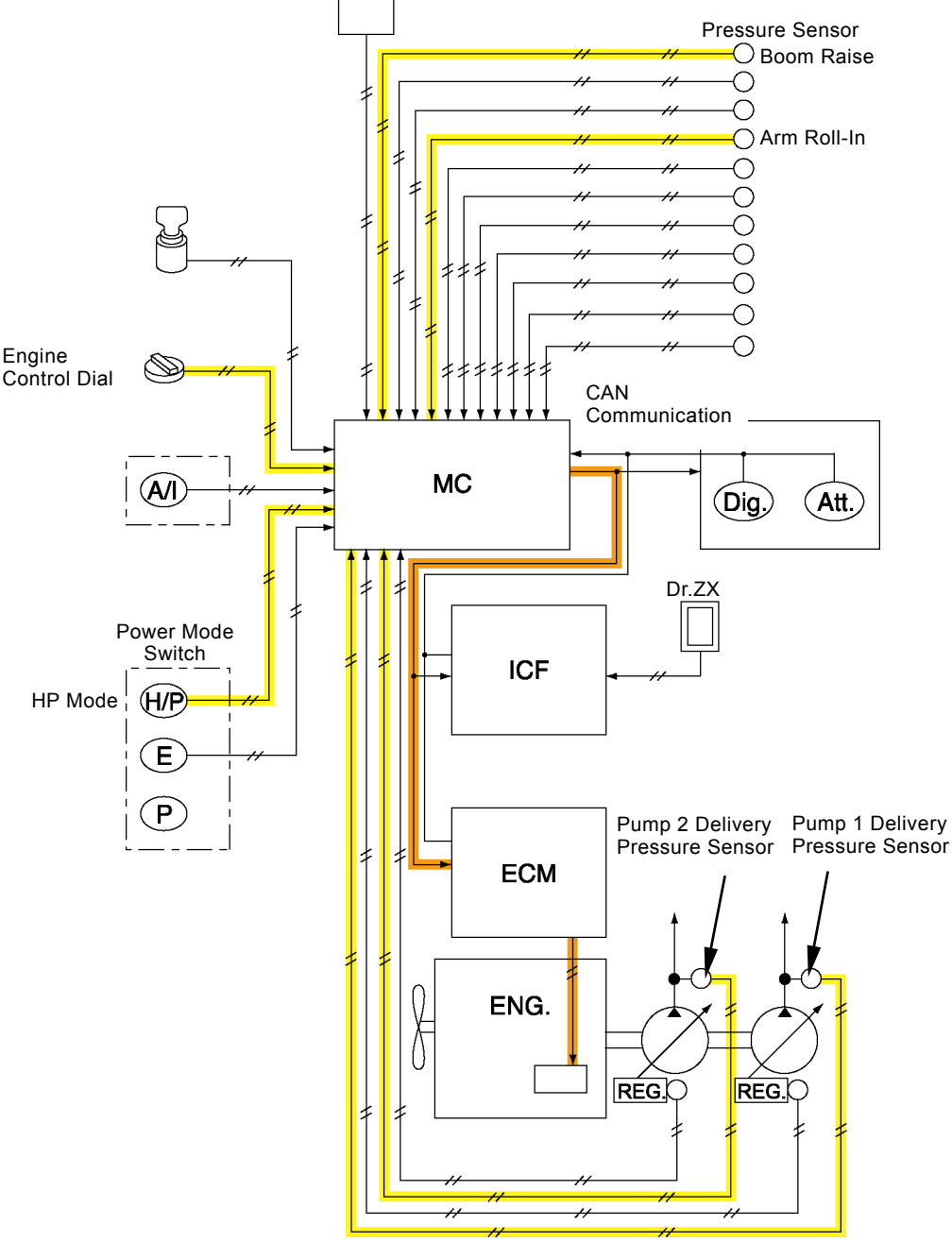

T1J1-02-02-023

## SYSTEM / Control System

### Travel Speed Increase Control

Purpose: Increases the engine speed and travels faster during travel single operation.

Operation:

1. When the following conditions exist, MC sends the signals equivalent to the target engine speed to ECM by using CAN communication.
2. ECM increases the engine speed by  $100 \text{ min}^{-1}$  from the speed set by the engine control dial and travels faster.

Condition:

- Engine Control Dial: Set the engine speed at  $1070 \text{ min}^{-1}$  or faster.
- Travel Operation: Operated

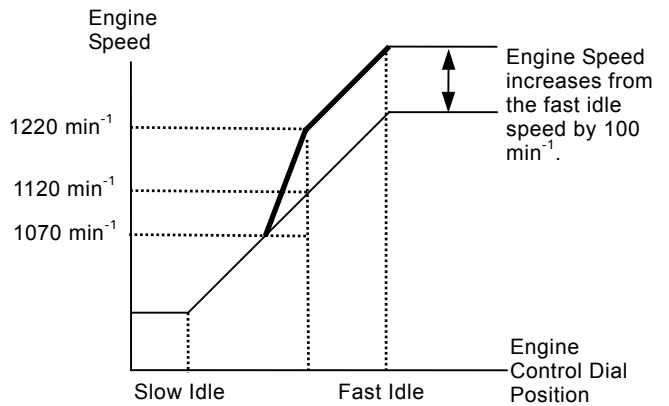

# SYSTEM / Control System

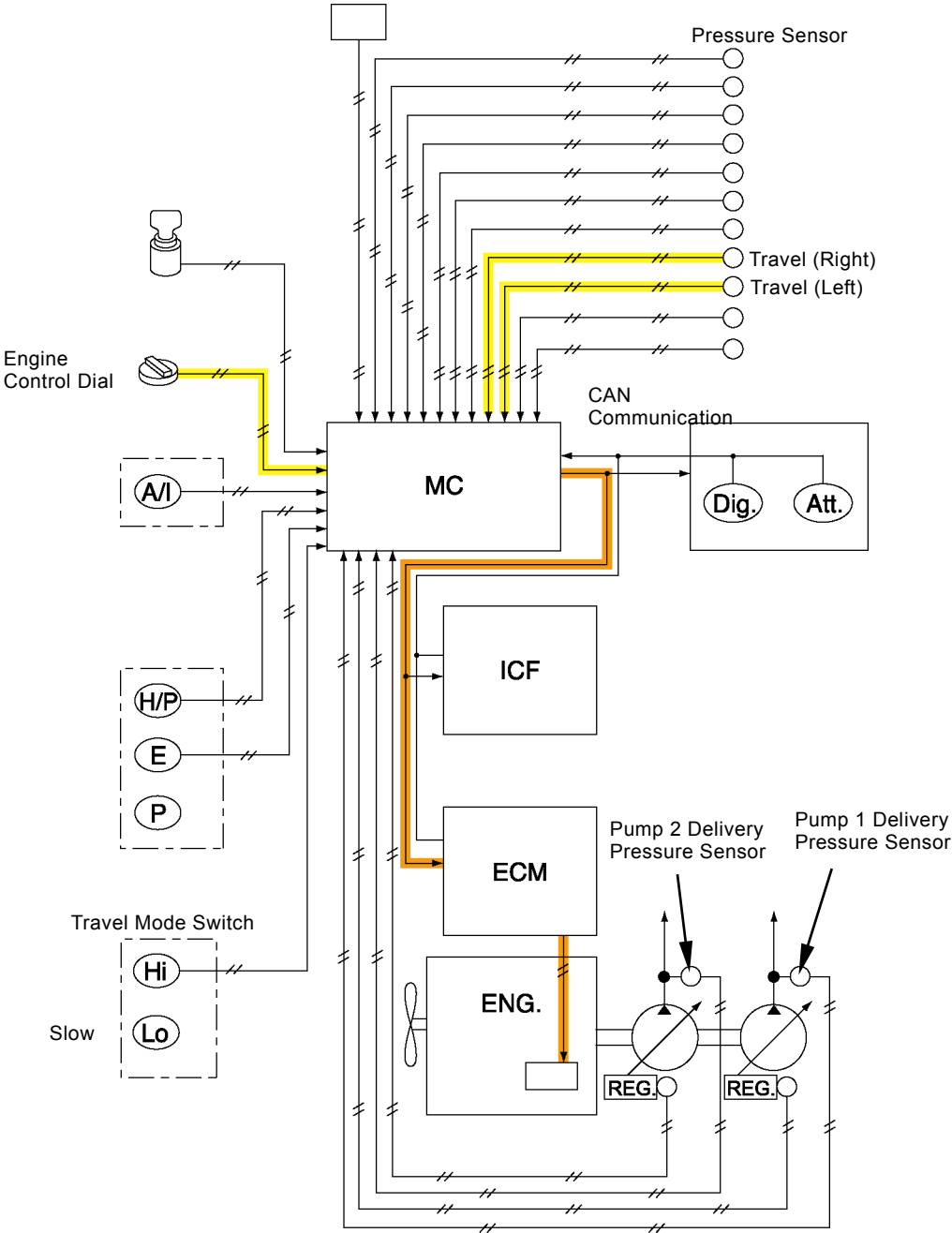

T1J1-02-02-024

**NOTE:** The illustration shows when the travel mode switch is in the SLOW position.



## SYSTEM / Control System

---

### E Mode Control

Purpose: Reduces the target engine speed to  $1580 \text{ min}^{-1}$  in maximum in order to reduce fuel consumption.

Operation:

1. When the following conditions exist, MC sends the signal equivalent to the target engine speed regulated at  $1580 \text{ min}^{-1}$  to ECM by using CAN communication.
2. ECM adjusts the engine speed to the target engine speed received from MC.

Condition:

- Engine Control Dial: Set the engine speed at  $1580 \text{ min}^{-1}$  or faster.
- Power Mode Switch: E mode

 **NOTE:** MC sends the target engine speed to ECM every 10 ms (0.01 second). MC changes the data to send to ECM according to the status.

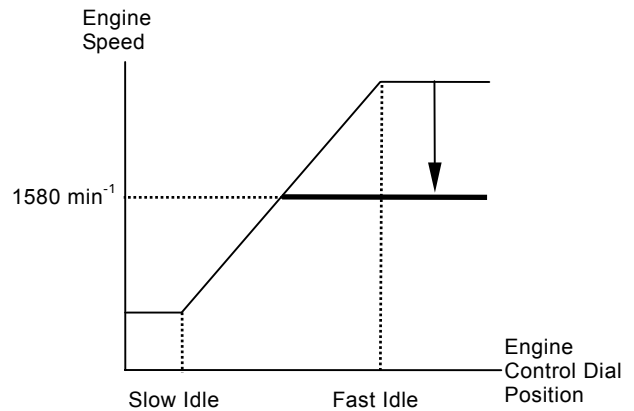

# SYSTEM / Control System

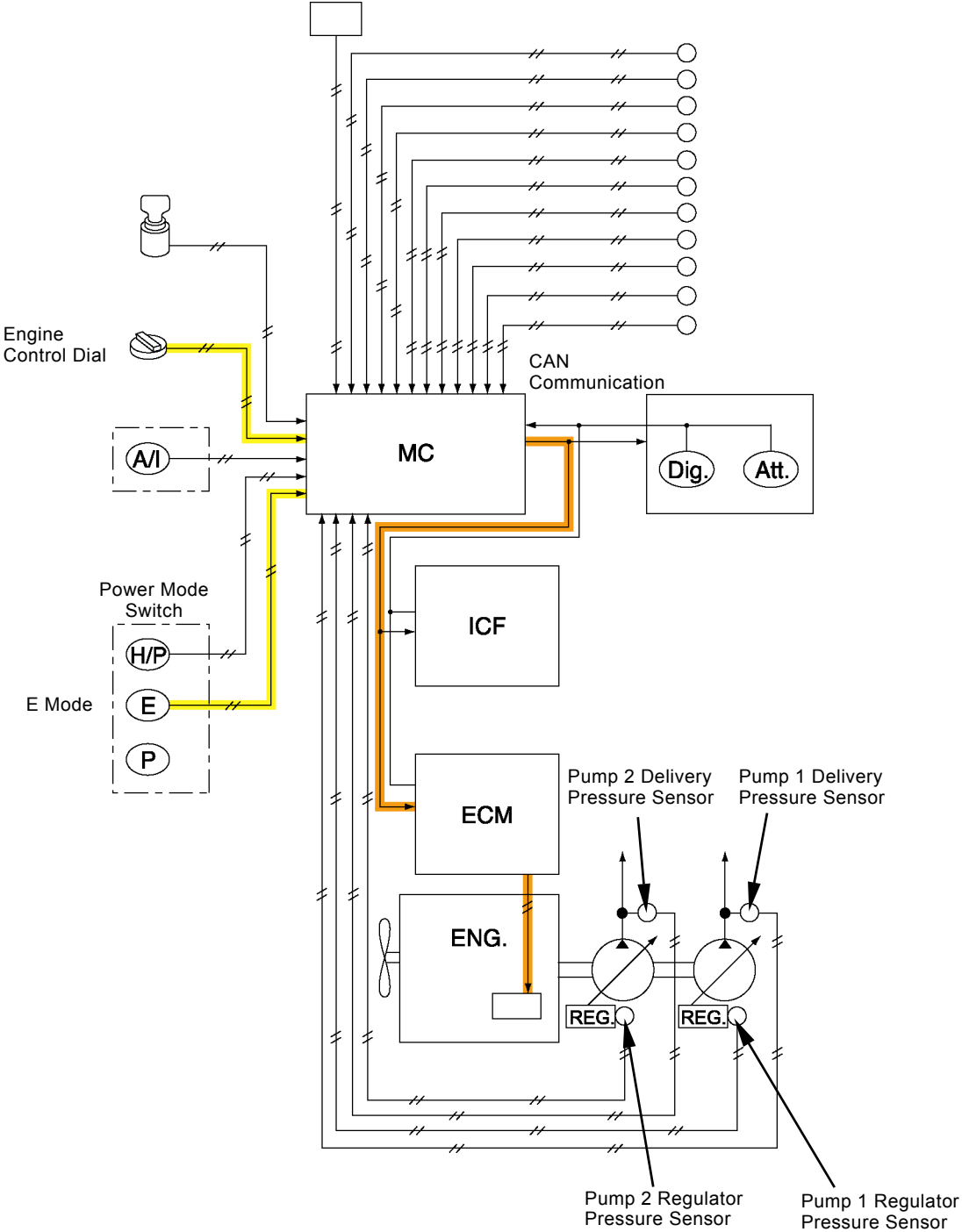

T1J1-02-02-025



# SYSTEM / Control System

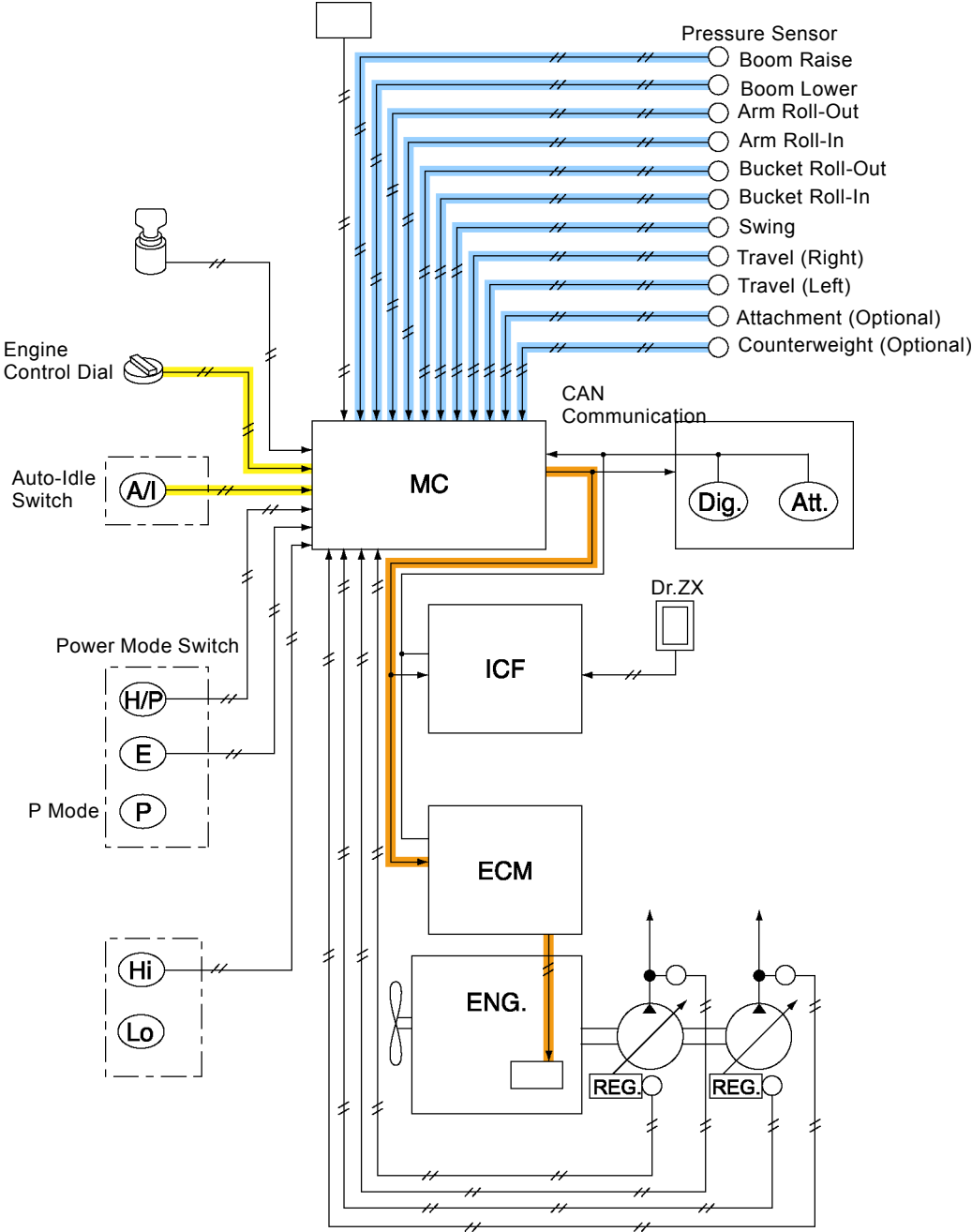

T1J1-02-02-026

## SYSTEM / Control System

### Attachment Operation Speed Increase Control (Only Machine Equipped with Front Attachment Parts)

**Purpose:** Increases the maximum engine speed to the attachment (breaker) operating engine speed set by Dr. ZX when the attachment is operated.

**Operation:**

1. When the following conditions exist and the attachment is operated, the MC sends the signals equivalent to the target engine speed set by Dr. ZX to ECM by using CAN communication.
2. ECM increases engine speed to the attachment operating speed set by Dr. ZX.

**Conditions:**

- Dr. ZX: Resets the maximum engine speed to a faster (+) attachment (breaker) operating speed in the service mode.
  - Engine Control Dial: Fast Idle Speed Position
  - Power Mode Switch: HP Mode
  - Attachment: Operated
  - Work Mode: Attachment Mode
- Set the attachment selected by DR. ZX to faster (+).

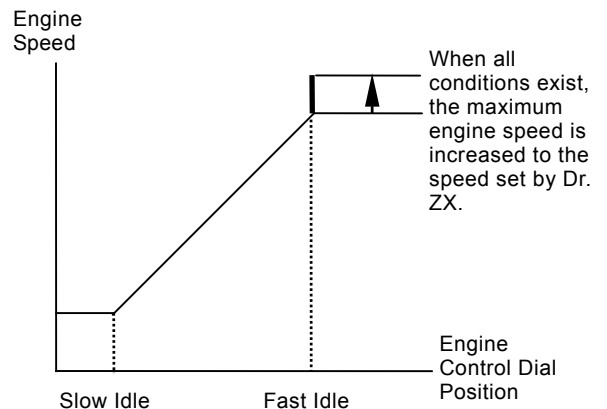

**NOTE:** When the P mode engine speed is preset to a slower speed in Dr. ZX service mode, the maximum engine speed will not be increased when operating the attachment.

# SYSTEM / Control System

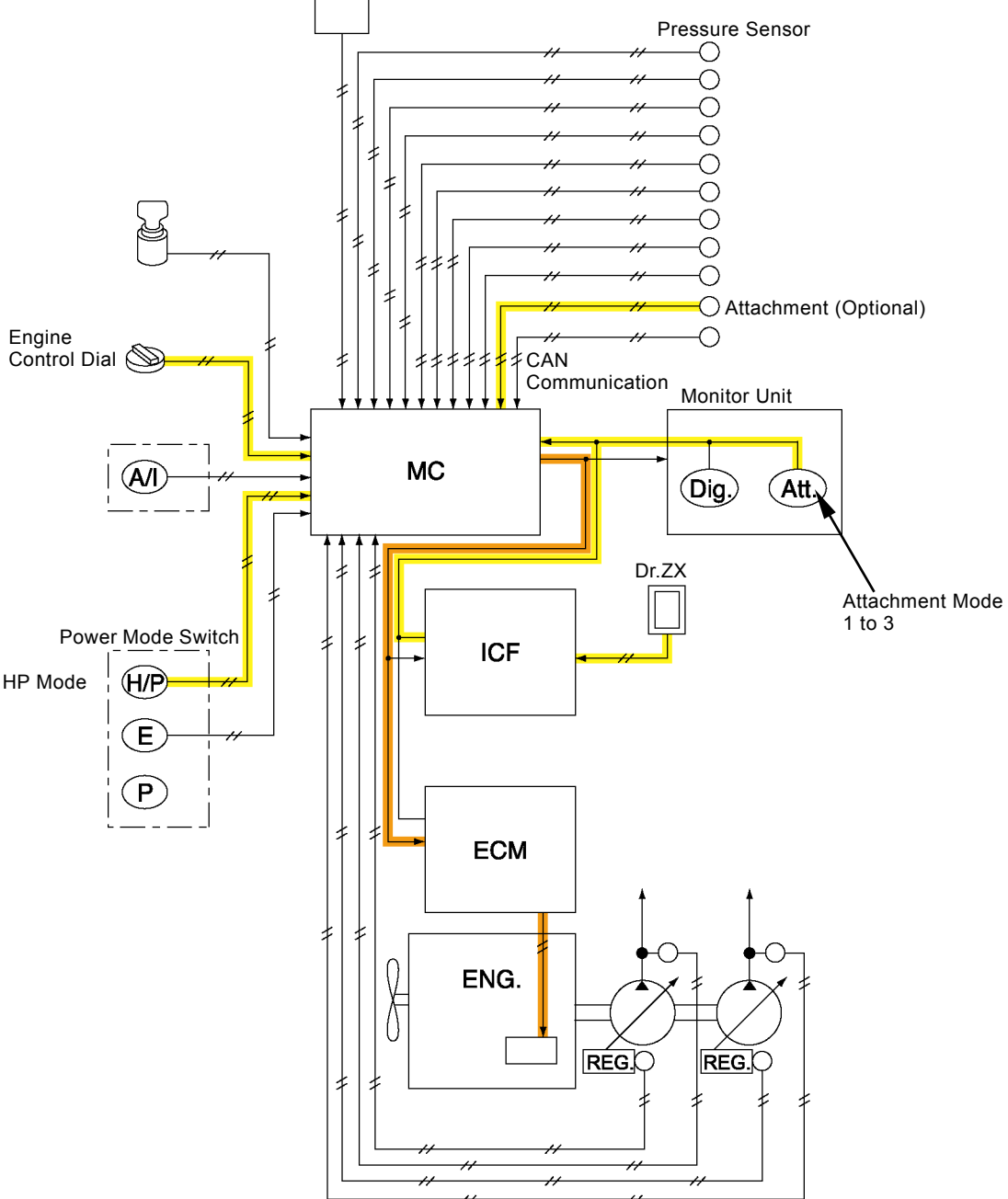

T1J1-02-02-030

## SYSTEM / Control System

---

### Attachment Operation Speed Decrease Control (Only Machine Equipped with Front Attachment Parts)

Purpose: Decreases the maximum engine speed to the attachment (breaker) operating engine speed set by Dr. ZX when the attachment mode is selected.

Operation:

1. When the following conditions exist and the front attachment is operated, MC sends the signals equivalent to the target engine speed set by Dr. ZX to ECM by using CAN communication.
2. ECM increases engine speed to the attachment operating speed set by Dr. ZX.

Conditions:

- Dr. ZX: Resets the maximum engine speed to a slower (-) attachment (breaker) operating speed in the service mode.
- Work Mode: Attachment Mode  
Set the attachment selected by Dr. ZX to slower (-)

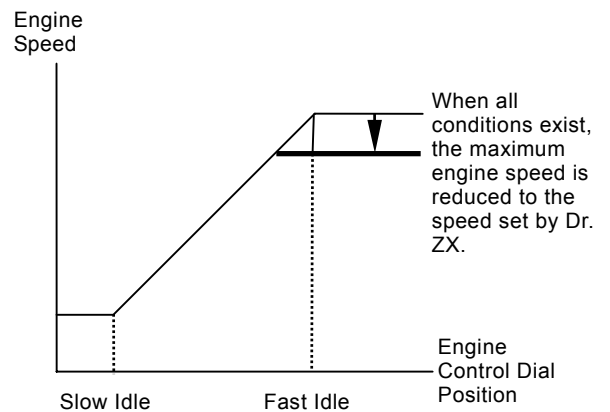

# SYSTEM / Control System

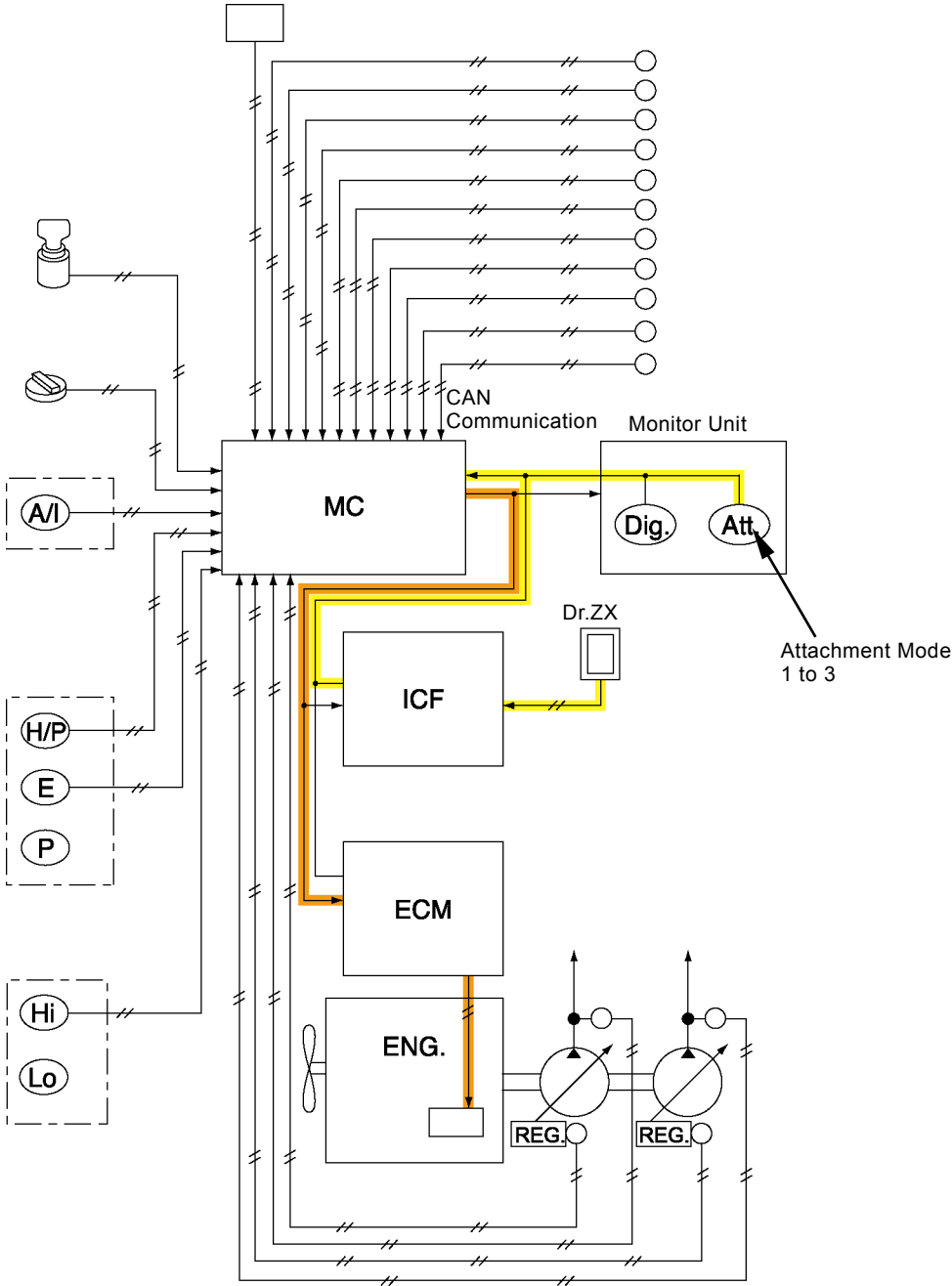

T1J1-02-02-031



## **SYSTEM / Control System**

---

(Blank)

# SYSTEM / Control System

## PUMP CONTROL

The pump control system has the following functions:

- Pump Flow Rate Control
- Speed Sensing Control
- Horsepower Control
- Relief Flow Rate Decrease Control
- Swing Horsepower Reducing Control
- Overheat Prevention Control
- Attachment Mode Control (Optional)
- Pump Control for Counterweight (Optional)
- Fan Pump Flow Rate Control
- Pump Learning Control

 **NOTE:** (Optional): This control is for only the machine with optional parts equipped.

### Pump Control System Layout

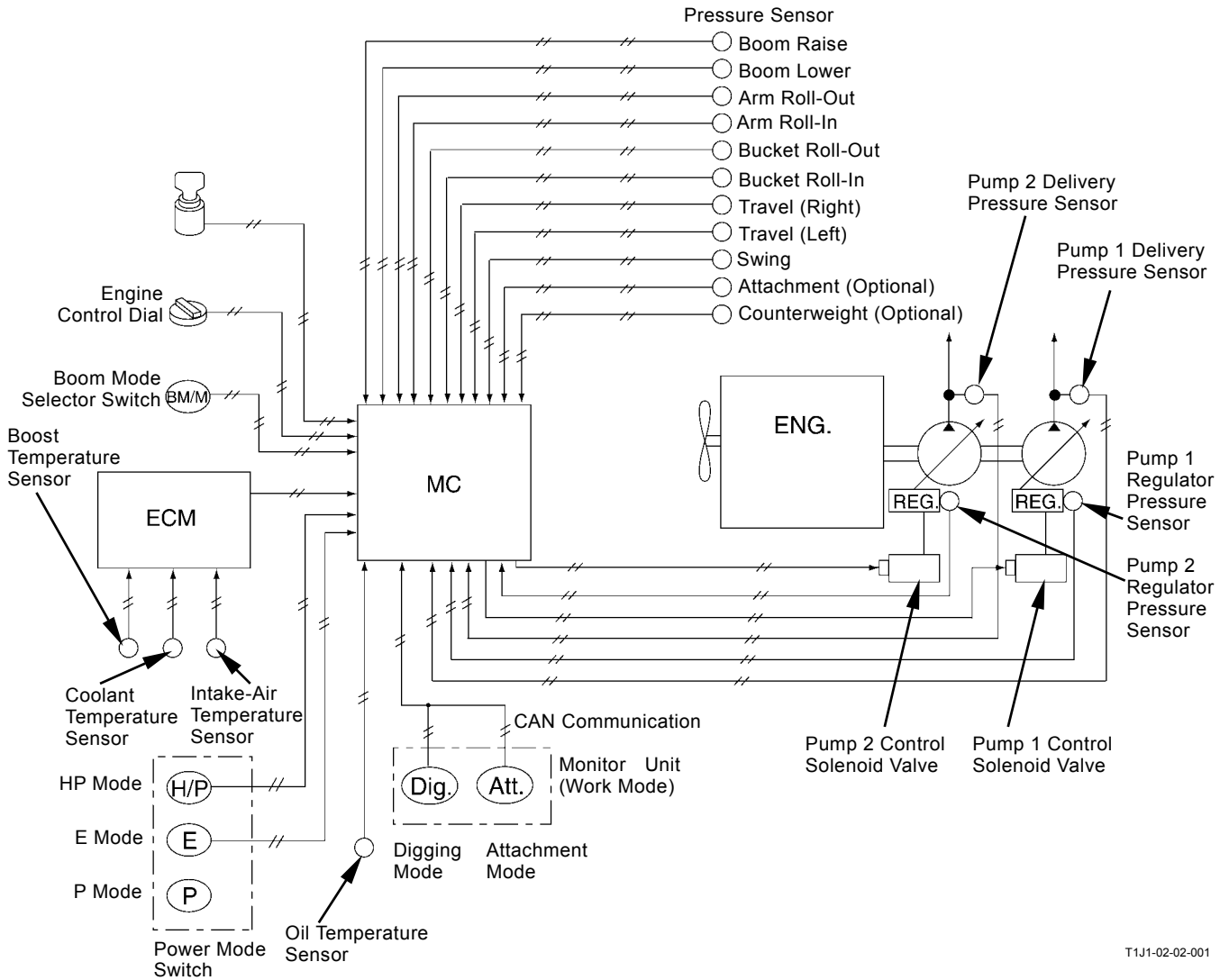

T1J1-02-02-001

## SYSTEM / Control System

---

### Pump Flow Rate Control

Purpose: Delivers oil required for the actuator from the main pump according to the control lever stroke.

Operation:

- Control Lever: Operated

1. When the control lever is operated, pressure oil from the pilot valve according to the control pressure acts on each pressure sensor.
2. Each pilot pressure sensor detects this pressure and sends the signal to MC.
3. MC compares with the actual pump swash angle detected by the pump 1 regulator sensor or pump 2 regulator sensor, calculates the required oil amount and drives the pump control solenoid valve.
4. Consequently, swash angle of the main pump becomes large and delivery flow rate of the main pump increases.

- Control Lever: In Neutral

1. When the control lever is in neutral, pilot pressure oil to each pressure sensor disappears.
2. Each pilot pressure sensor detects no pressure and sends the signal to MC.
3. MC compares with the actual pump swash angle detected by the pump 1 regulator sensor or pump 2 regulator sensor, calculates the required oil amount and drives the pump control solenoid valve.
4. Consequently, swash angle of the main pump becomes minimum and delivery flow rate of the main pump becomes minimum.

 **NOTE:** *The boom is lowered due to own weight by the boom regenerative valve during boom lower operation. Therefore, during boom lower operation, delivery flow rate of the main pump does not increase.*

# SYSTEM / Control System

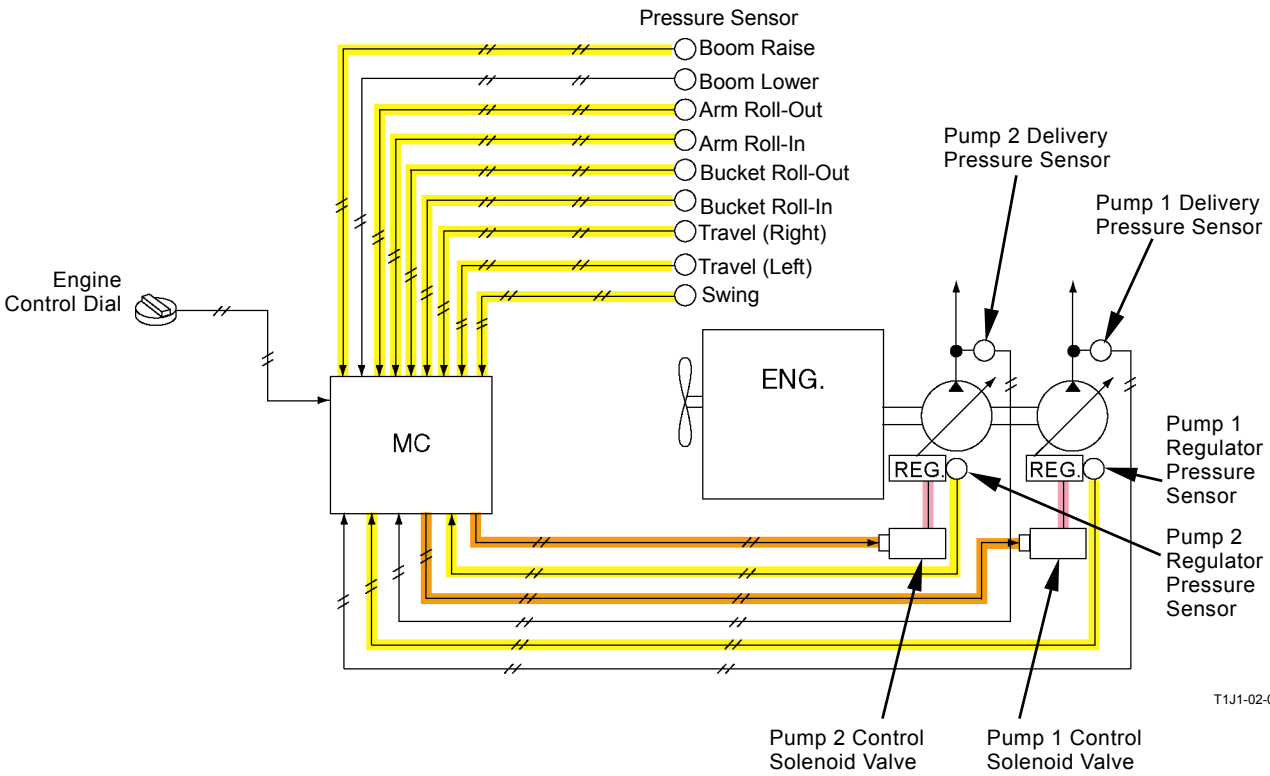

T1J1-02-02-002

# SYSTEM / Control System

## Speed Sensing Control

Purpose: Controls the pump flow rate in response to engine speed changes due to variations in load so that the engine output can be utilized more efficiently. (Engine stall is prevented when the machine operates under adverse conditions such as operating at high altitude.)

Operation:

1. The target engine operating speed is set by controlling the engine control dial.
2. MC calculates the difference in speed between the target engine speed and the actual engine speed input from ECM. Then, MC sends signals to the pump control solenoid valve.
3. The pump control solenoid valve delivers pilot pressure oil in response to the received signals to the pump regulator and controls the pump delivery flow rate.
4. If the engine load increases and the actual engine speed becomes slower than the target engine speed, the pump swash angle is reduced so that pump flow rate will be reduced. Therefore, the engine load is reduced and engine stall is prevented.
5. If the actual engine speed becomes faster than the target engine speed, the pump swash angle is increased so that pump flow rate will increase. Therefore, the engine output can be utilized more efficiently.

 **NOTE:** As for the actual engine speed, ECM calculates the signals from crank speed sensor and cam angle sensor and sends to MC.

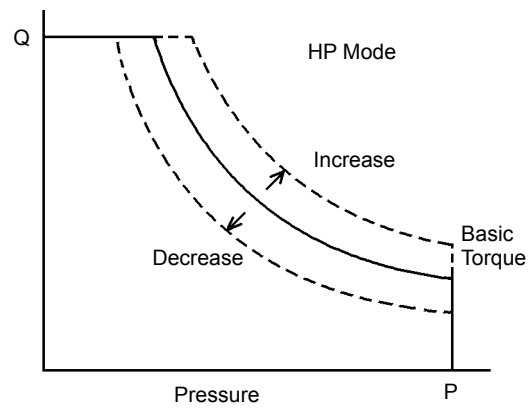

T111-05-02-004

Pump P-Q Curve

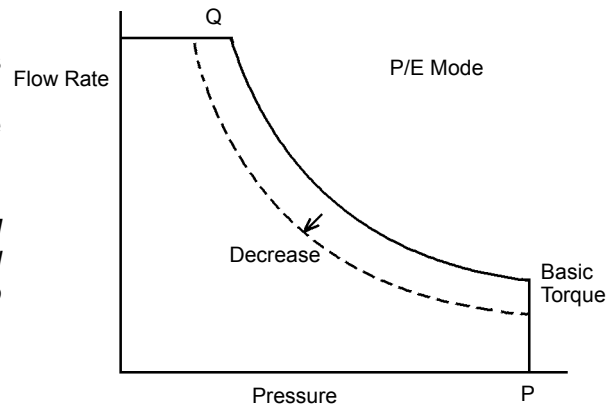

T166-02-01-014

# SYSTEM / Control System

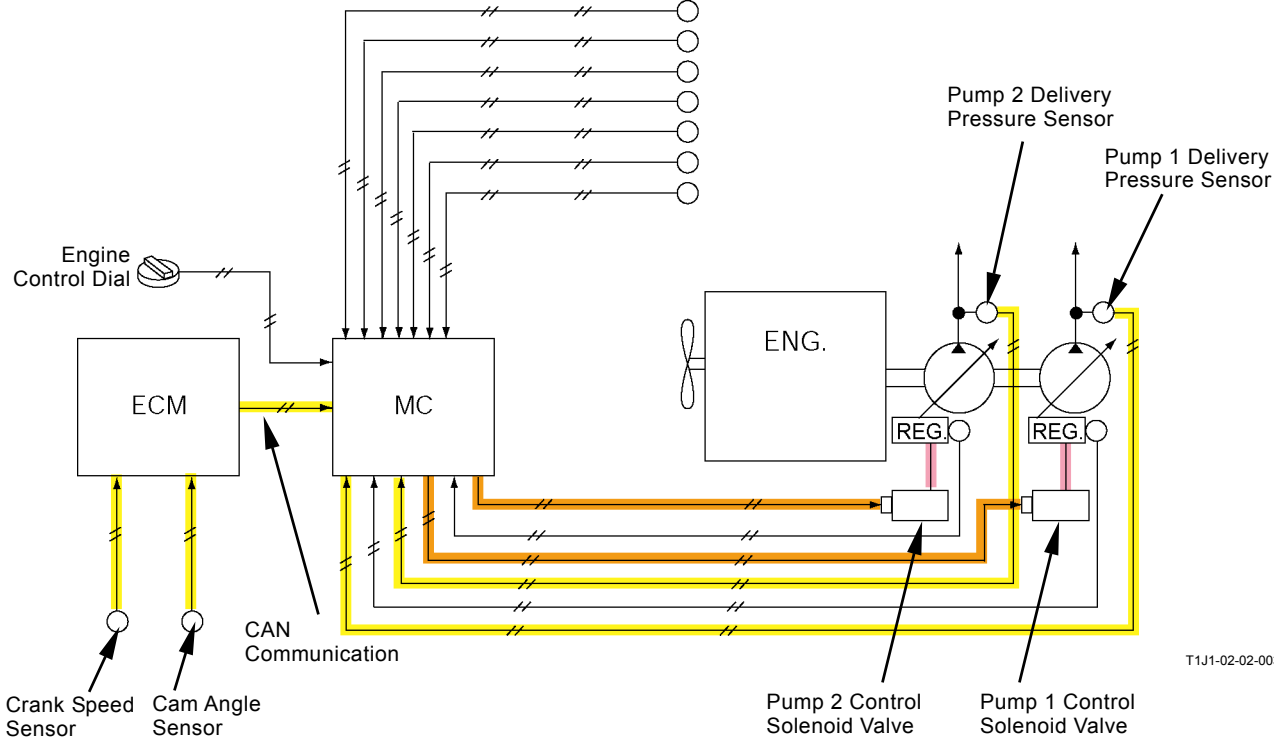

T1J1-02-02-003

# SYSTEM / Control System

## Horsepower Control

Purpose: Controls delivery flow rate of each main pump and uses engine power effectively so that sum of pump torques divided to two main pumps and fan pump does not exceed the engine output torque.

**NOTE:** Delivery flow rate of the fan pump is controlled by the fan pump flow rate control regardless with engine output power. (Refer to T2-2-38.)

### Operation:

1. In normal, delivery pressure difference between main pumps 1 and 2 occurs with two pumps operated.
2. Larger load is applied to the main pump with higher delivery pressure and smaller load is applied to that with lower delivery pressure.
3. The pump delivery pressure sensor and pump regulator pressure sensor detect this status and send the signal to MC.
4. MC calculates the maximum target pump displacement angle according to the signals from two main pump delivery pressure sensors so that sum of pump torques of main pumps 1,2 and fan pump does not exceed the engine output power.
5. MC compares actual pump displacement angle detected by the pump regulator pressure sensor with the target pump displacement angle.
6. MC activates the pump control solenoid valve at the side with larger load in order to compensate for the difference between the actual and target pump displacement angles, and increases delivery flow rate of the main pump with larger load.

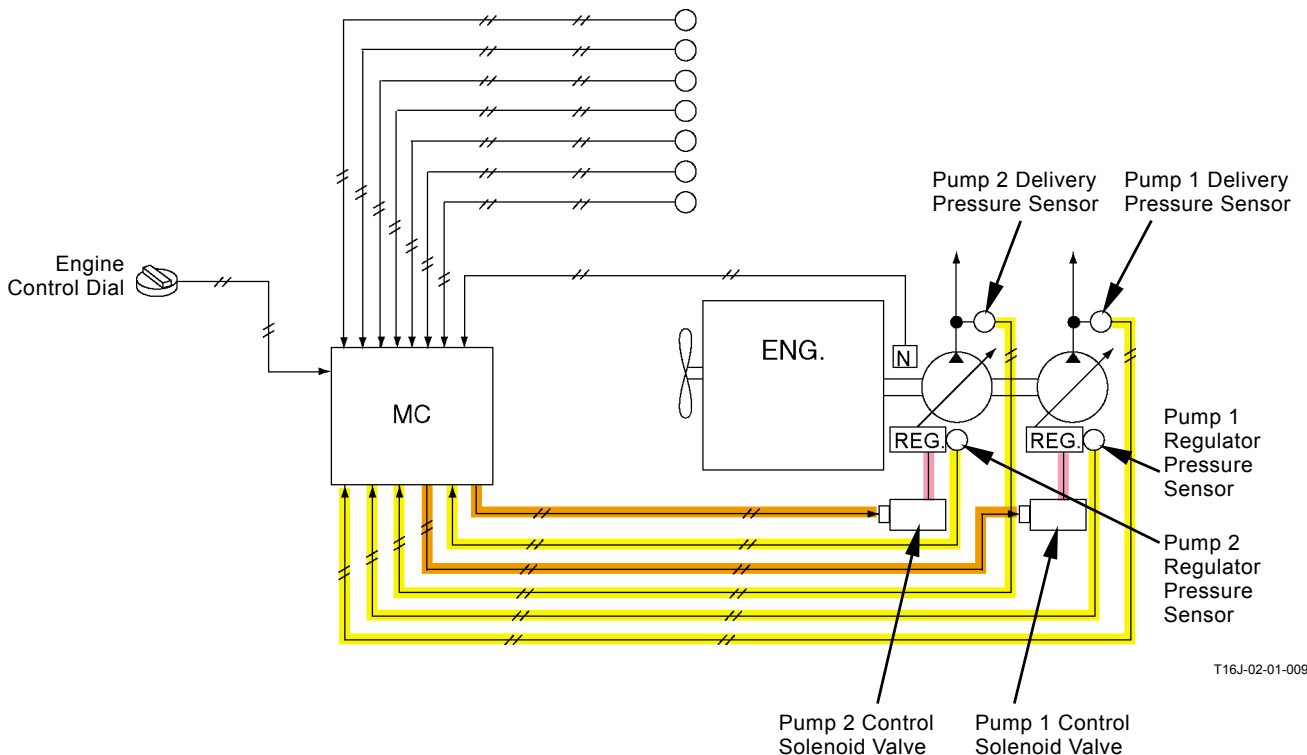

# SYSTEM / Control System

## Relief Flow Rate Reducing Control (Relief Cut Off)

Purpose: Reduces hydraulic energy loss and prevents hydraulic oil temperature from rising. (Flow Rate Reducing Control (Relief Cut Off))

Operation:

1. When an actuator is operated, the pump delivery pressure varies due to changing load applied to each actuator.
2. The pump delivery pressure sensor detects delivery pressure and sends the signals to MC.
3. When pump delivery pressure reaches 30.9 MPa (315 kgf/cm<sup>2</sup>, 4490 psi), MC compares pump delivery pressure with the actual pump displacement angle detected by the pump regulator pressure sensor, and activates the pump control solenoid valve. Therefore, pump delivery flow rate decreases and becomes the minimum flow rate.
4. If the pressure sensor (travel right or left) detects travel pilot pressure or the pressure sensor (swing) detects swing pilot pressure, MC cancels the relief flow rate reducing control to the main pump (relief cut off override).

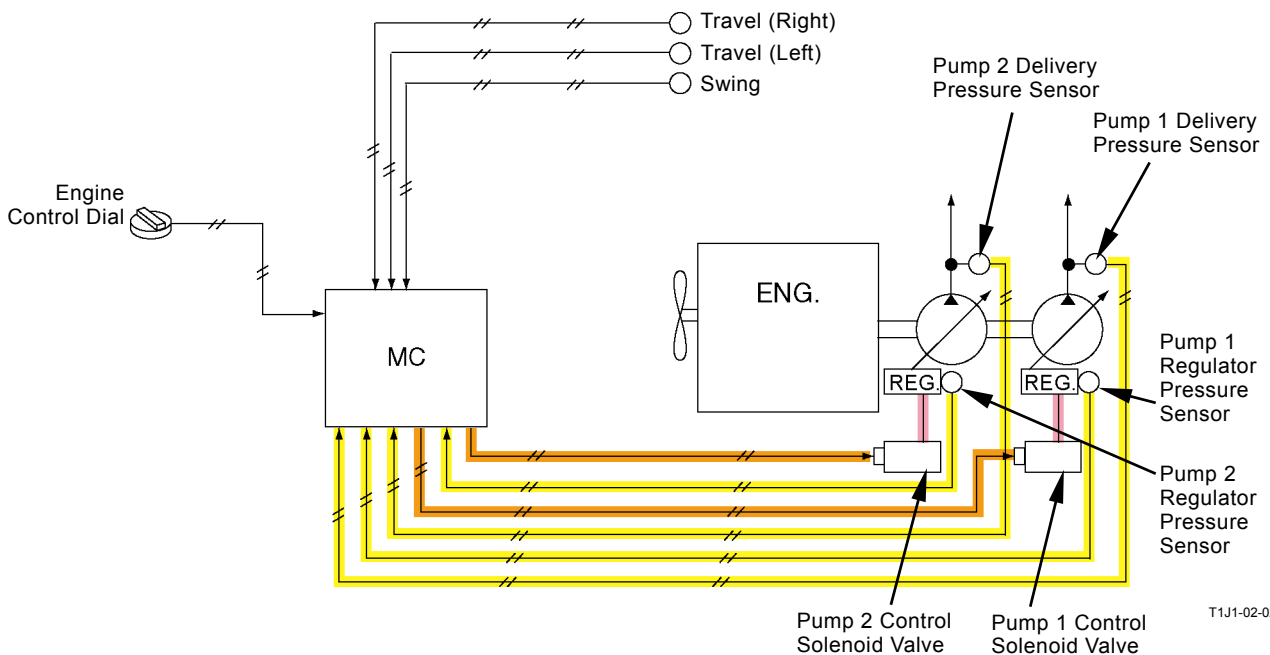
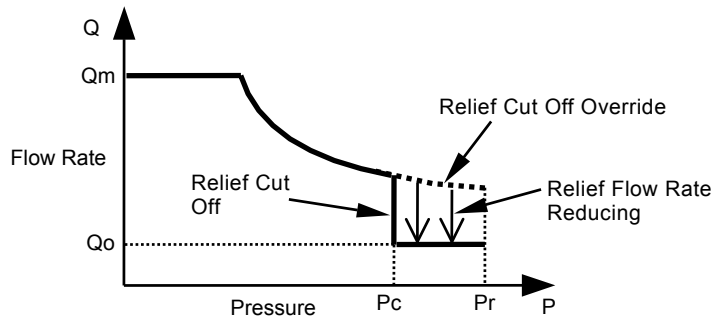

T1J1-02-02-005



# SYSTEM / Control System

## Swing Horsepower Reducing Control

Purpose: Decreases delivery flow rate of main pump 2 including the swing circuit, increases delivery flow rate of main pump 1 and uses the engine power effectively when the swing control lever is operated and the pressure sensor (swing) detects swing pilot pressure.

### Operation:

1. The pressure sensor (swing) detects swing pilot pressure and sends a signal to MC when the swing function is operated.
2. MC calculates the target pump displacement angle according to a signal from the pump delivery pressure sensor. Then, MC compares the target displacement angle with the actual pump displacement angle detected by the pump regulator pressure sensor.
3. MC activates the pump control solenoid valve in main pump 2 in order to compensate the difference between the actual and target displacement angles, and decreases pump delivery flow rate.
4. If the combined operation of swing and travel, or swing and front attachment is operated, the pressure sensors (swing, travel, boom raise/lower, arm roll-out/in, bucket roll-out/in and attachment) detect pilot pressure respectively and send a signal to MC.
5. MC activates the control solenoid valve in main pump 1 and increases pump delivery flow rate.

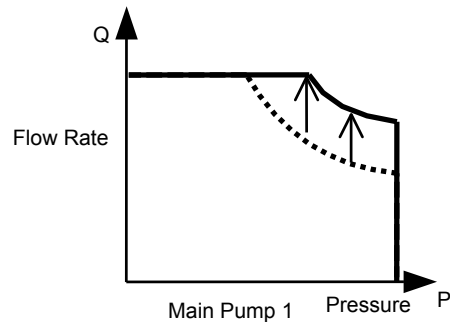
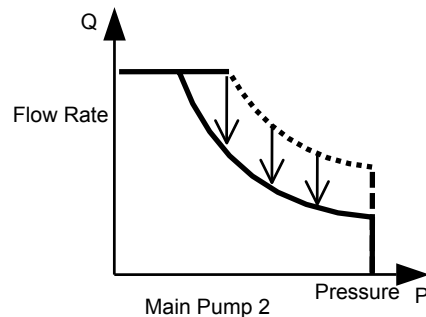

# SYSTEM / Control System

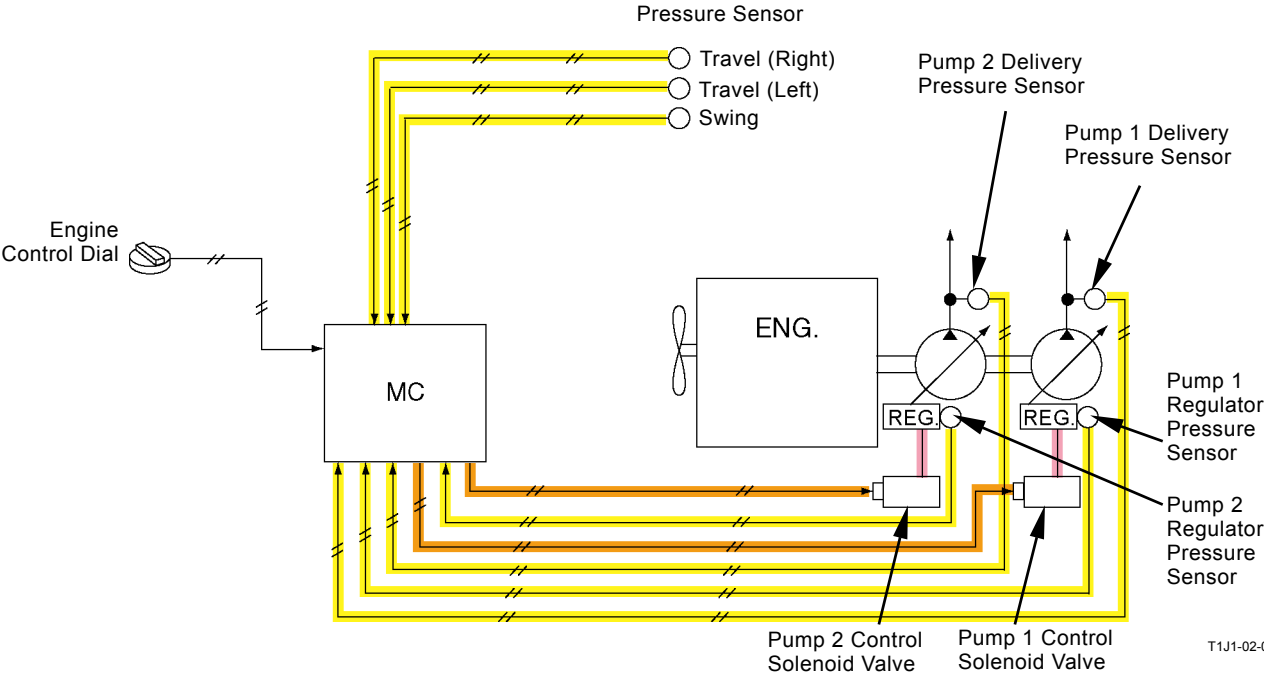

T1J1-02-02-006

**NOTE:** The illustration shows during combined operation of swing and travel.

## SYSTEM / Control System

### Overheat Prevention Control

Purpose: Prevents the engine from overheating by reducing the main pump maximum flow rate and pump torque, reducing the load applied to the engine when coolant and hydraulic oil temperatures increase beyond the specified level.

#### Operation:

1. The signal from coolant temperature sensor is sent to MC via ECM and CAN.
2. When coolant temperature is 99 °C (210 °F) or higher, MC calculates the target pump displacement angle according to the signal from the pump delivery pressure sensor. MC compares the actual pump displacement angle detected by the pump regulator pressure sensor with the target pump displacement angle.
3. MC activates the pump control solenoid valve in order to compensate the difference between the actual and target displacement angles, and decreases 7 % of pump torque.
4. The signal from the oil temperature sensor is sent to MC
5. When coolant temperature is 100 °C (212 °F) or higher, MC calculates the target pump displacement angle according to the signal from the pump delivery pressure sensor. MC compares the actual pump displacement angle detected by the pump regulator pressure sensor with the target pump displacement angle.
6. MC activates the pump control solenoid valve in order to compensate the difference between the actual and target displacement angles, and decreases maximum flow rate and 7 % of pump torque.

#### Completion Condition for Overheat Control

- Coolant temperature 95 °C (203 °F) or lower
- Hydraulic oil temperature: 95 °C (203 °F) or lower

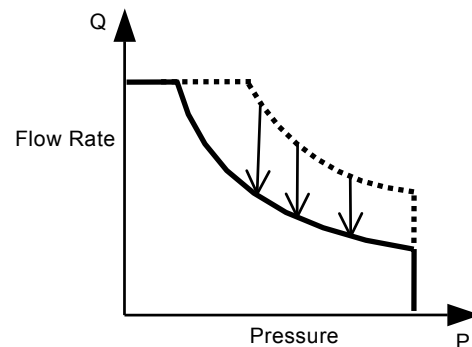
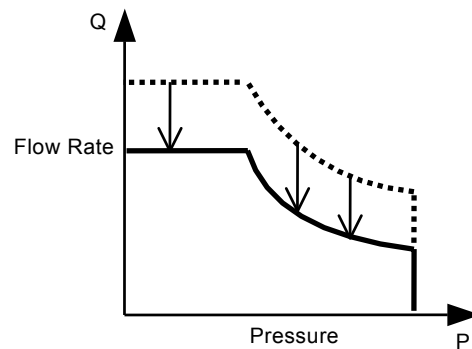

# SYSTEM / Control System

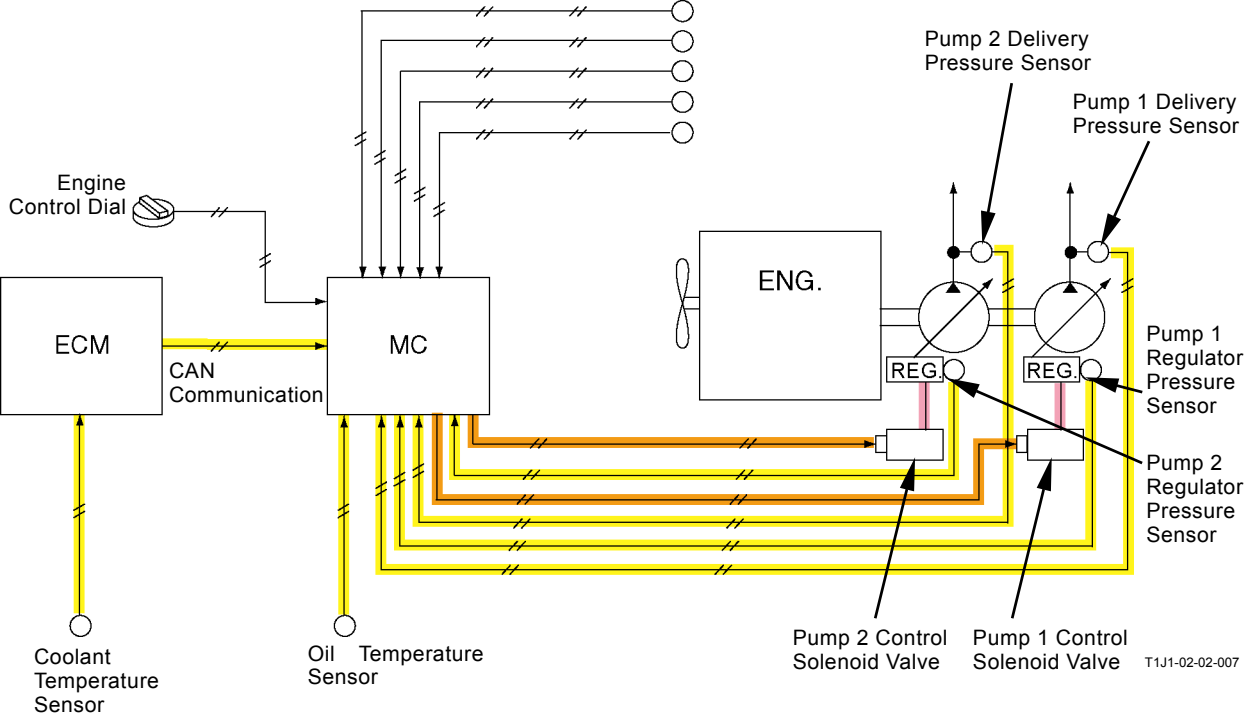

## SYSTEM / Control System

### Attachment Mode Control (Only Machine Equipped with Front Attachment)

Purpose: Limits the upper of maximum flow rate of pump 2 and controls the appropriate flow rate for the attachment when operating the attachment with the work mode in attachment mode.

 **NOTE:** When the attachment mode is shifted, the maximum flow rate setting (469 L/min (124 gpm)) at normal control (digging mode) can be selected as the table below.

Mode	Maximum Flow Rate	Breaker
Breaker 1	230 L/min (61 gpm)	Mitsubishi (MKB3000V)
Breaker 2	260 L/min (69 gpm)	Okada (OUB330) Mitsubishi (MKB4000V)
Breaker 3	300 L/min (79 gpm)	Furukawa (F70)
Breaker 4	320 L/min (85 gpm)	Hitachi (HSB100) NPK (E-240A)

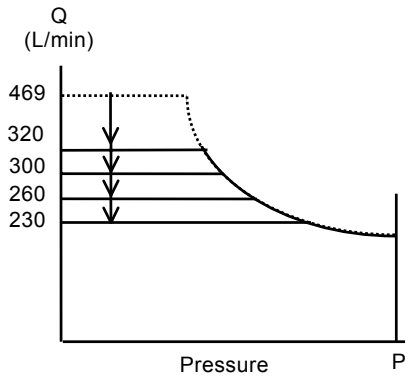

#### Operation:

1. When the work mode is in the attachment mode position and the breaker (attachment pilot valve) is operated, the pressure sensor (attachment) detects attachment pilot pressure and sends the signal to MC.
2. At the same time, the selection information of attachment mode is sent to MC.
3. MC always detects the displacement angle detected by the pump regulator pressure sensor.
4. MC activates the pump 2 control solenoid valve and keeps the displacement angle when the displacement angle of pump 2 increases to the position for maximum flow rate indicated at the attachment mode.
5. As the attachment is controlled by the auxiliary spool at 5-spool section in control valve, only maximum flow rate of pump 2 is controlled.

 **NOTE:** If operating the attachment at digging mode, flow rate of pump 2 is kept minimum.

 **NOTE:** As return oil from the breaker flows to the hydraulic oil tank directly without flowing through the oil cooler, hydraulic oil temperature increases. In order to prevent this, when operating the breaker, MC activates pump 1 flow rate control solenoid valve and increases delivery flow rate of pump 1. Consequently, as oil amount through the oil cooler increases, hydraulic oil temperature does not increase and overheating is prevented when operating the breaker.

# SYSTEM / Control System

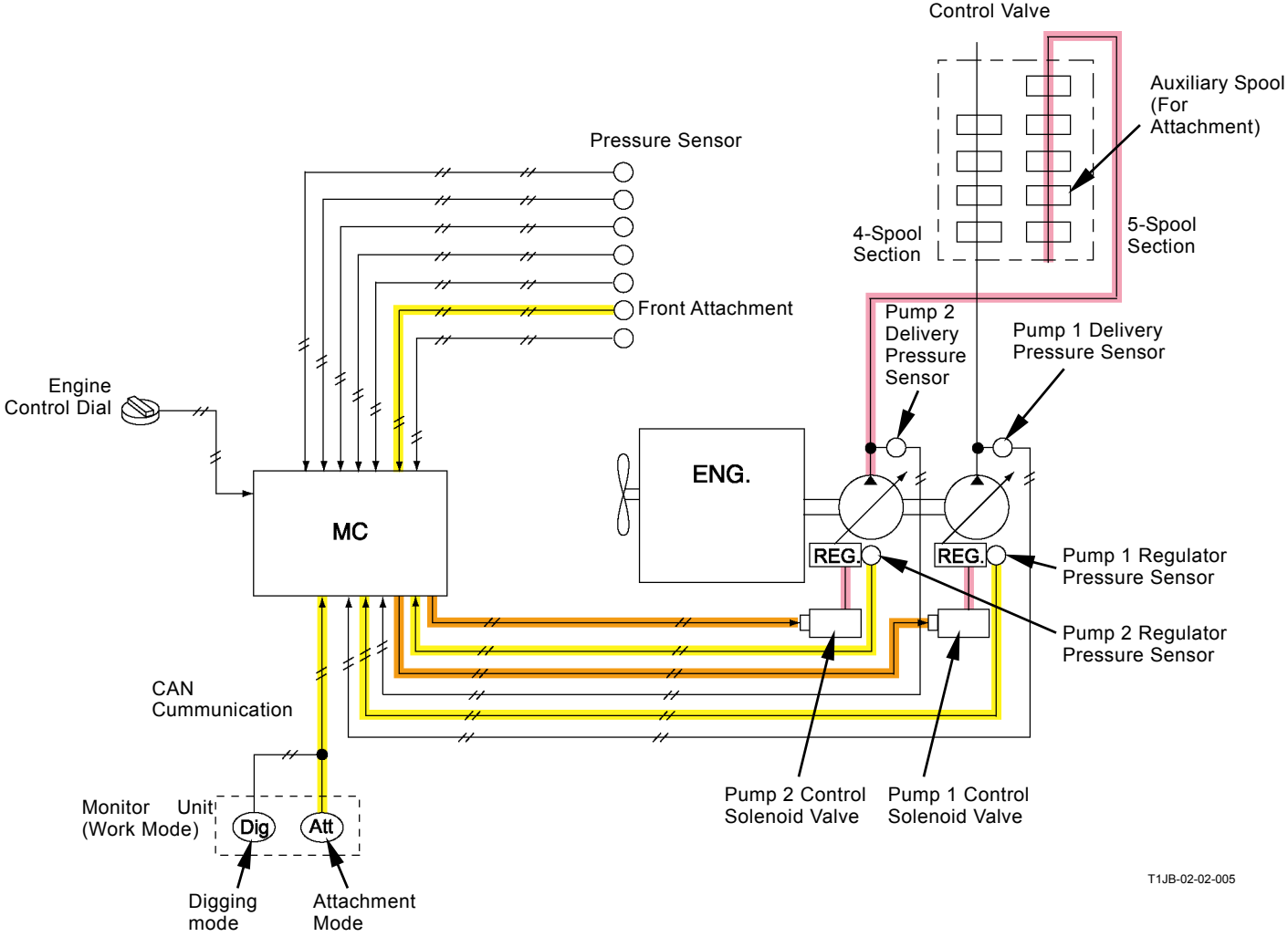

T1JB-02-02-005

## SYSTEM / Control System

---

### Counterweight Removal and Installation Control (Optional)

Purpose: Applies back-pressure to the main relief valve, increases main relief pressure and the hoist / lower power improves. Or, Controls pump delivery flow rate and makes fine operation easy.

#### Operation:

1. When the counterweight hoist / lower lever (optional) is operated, the pressure sensor (counterweight) detects pilot pressure and sends the signal to MC.
2. MC activates solenoid valve unit (SG).
3. Pressure oil from the pilot pump flows to the back of main relief valve.
4. Pressure oil compresses the spring of main relief valve and relief pressure increases. (Refer to the Control valve group / COMPONENT OPERATION.)
5. MC compares actual pump displacement angle detected by the pump 1 or 2 regulator pressure sensor with the target pump displacement angle. MC calculates required oil amount and activates the pump control solenoid valve.
6. Delivery flow rates of pumps 1, 2 become minimum.

 **NOTE:** *Main Relief Pressure:*  
*During normal operation: 31.9 MPa(325 kgf/cm<sup>2</sup>)*  
*During pressure increasing operation: 34.3 MPa(350 kgf/cm<sup>2</sup>)*

# SYSTEM / Control System

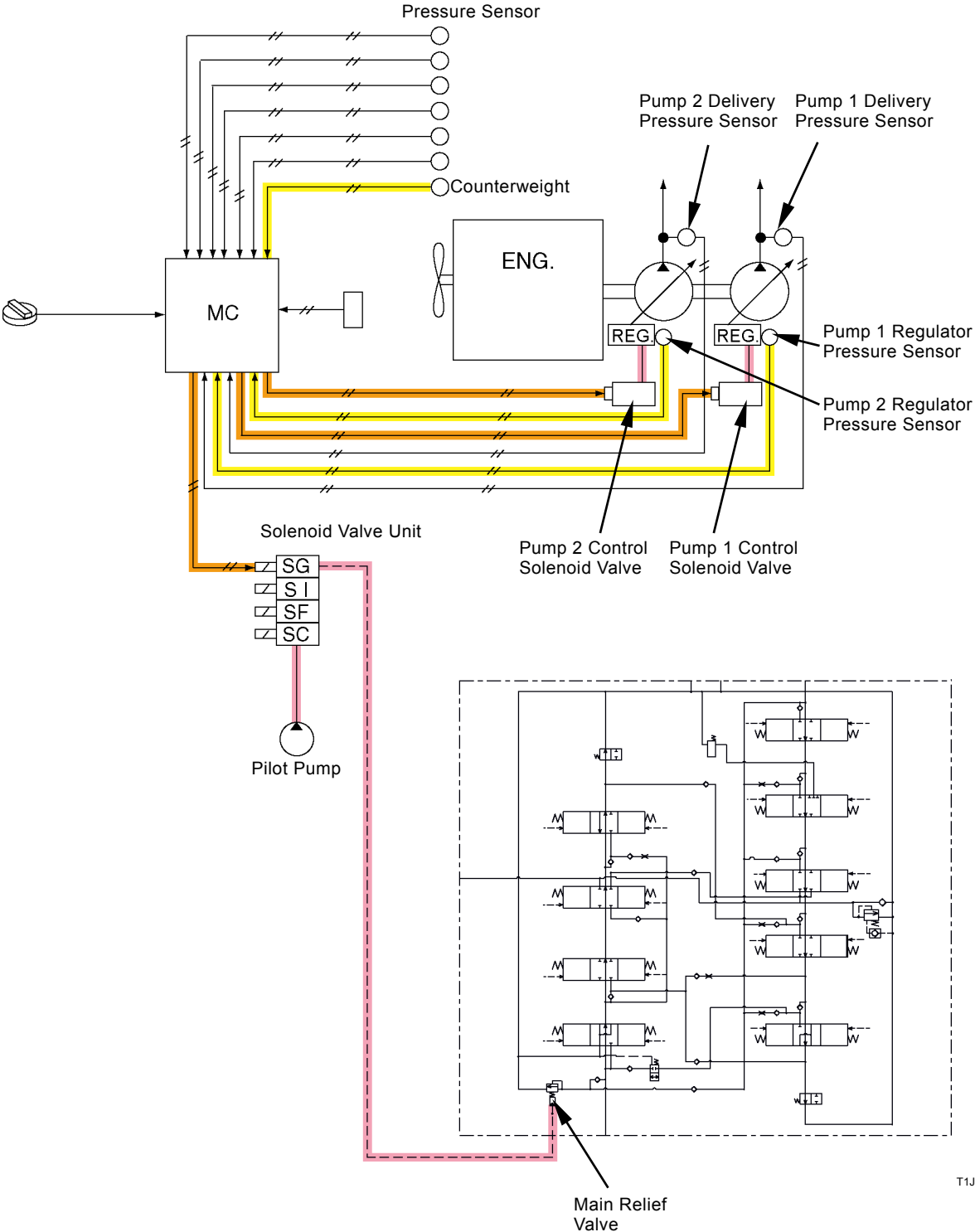

T1J1-02-02-009



## SYSTEM / Control System

---

### Fan Pump Flow Rate Control

Purpose: Controls delivery flow rate of the fan pump according to boost temperature, coolant temperature, hydraulic oil temperature and intake air temperature. Controls deliver flow rate of the fan pump in order not to decrease although engine speed is slow with the air conditioner ON. Therefore, controls fan rotation speed in order to make temperature of oil cooler, radiator and intercooler appropriate.

#### Operation:

- Blower Motor Relay (Air Conditioner Switch): OFF
  1. The signals from boost temperature sensor and coolant temperature sensor are sent to MC via ECM and CAN.
  2. The signal from oil temperature sensor is sent to MC.
  3. MC calculates fan rotation speed according to each signal.
  4. MC sends the fastest value of fan rotation speed to the fan pump control solenoid valve and controls delivery flow rate of the fan pump.
  5. Consequently, fan rotation speed is controlled properly.
- Blower Motor Relay (Air Conditioner Switch): ON
  1. The signals from boost temperature sensor, coolant temperature sensor and in-take air temperature sensor are sent to MC via ECM and CAN.
  2. The signal from oil temperature sensor is sent to MC.
  3. The signal of target engine speed from engine control dial is sent to MC.
  4. MC calculates fan rotation speed according to each signal.
  5. MC sends the fastest value of fan rotation speed to the fan pump control solenoid valve and controls delivery flow rate of the fan pump
  6. Consequently, fan rotation speed is controlled properly regardless with engine speed.

# SYSTEM / Control System

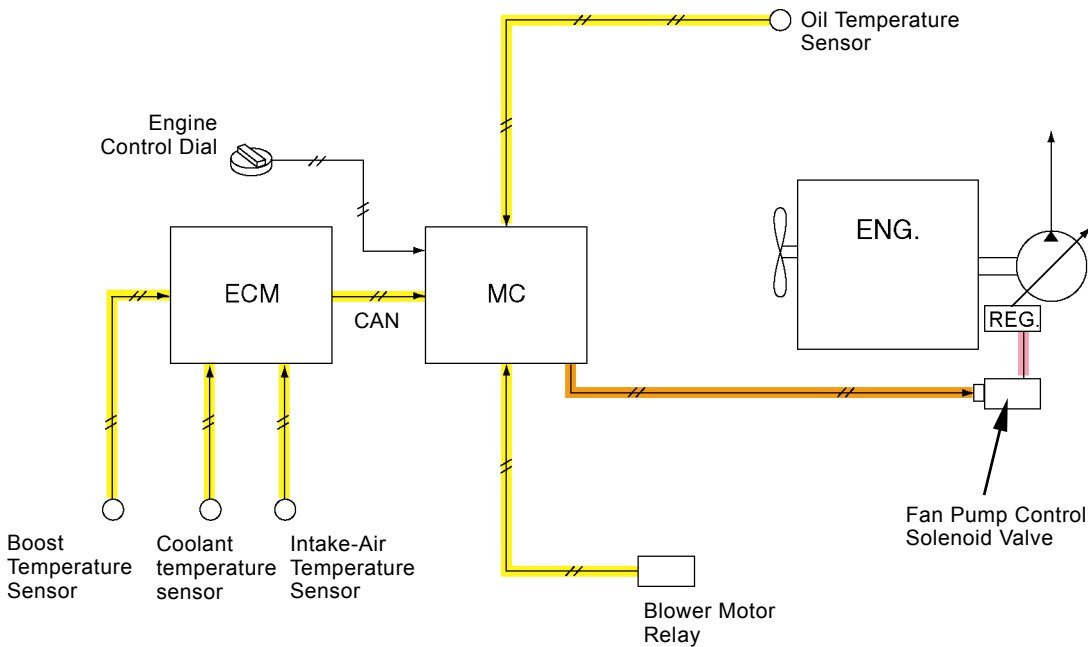

T1J1-02-02-010

## SYSTEM / Control System

---

### Pump Learning Control

Purpose: Detects pressure which is necessary to pump control, when the pump control solenoid valve is activated.

Operation:

1. When the following conditions exist and the learning switch in the rear console is turned to the pump learning position (opposite to E), MC activates the pump control solenoid valve.
2. Therefore, the spool in pump control solenoid valve is operated.
3. The regulator pressure sensor detects variable pressure at this time and sends the signal according to each pressure to MC.
4. MC records electrical current and pressure when the pump control solenoid valve is activated.

Condition:

- Engine: Running
- Engine Control Dial: Fast Idle
- Auto-Idle Switch: OFF
- Power Mode Switch HP Mode
- Pressure Sensor: Output zero. (The control lever is in neutral.)
- Hydraulic Oil Temperature:  $50\pm 5$  °C ( $122\pm 41$  °F)
- Pilot Shut-Off Lever: LOCK Position

**IMPORTANT: Perform the pump learning if the following work is done. (Refer to the Troubleshooting section in T/M.)**

- Replace the pump, pump regulator and pump control solenoid valve
- Replace MC

 **NOTE:** *The pump learning is not required when the batteries are replaced.*

# SYSTEM / Control System

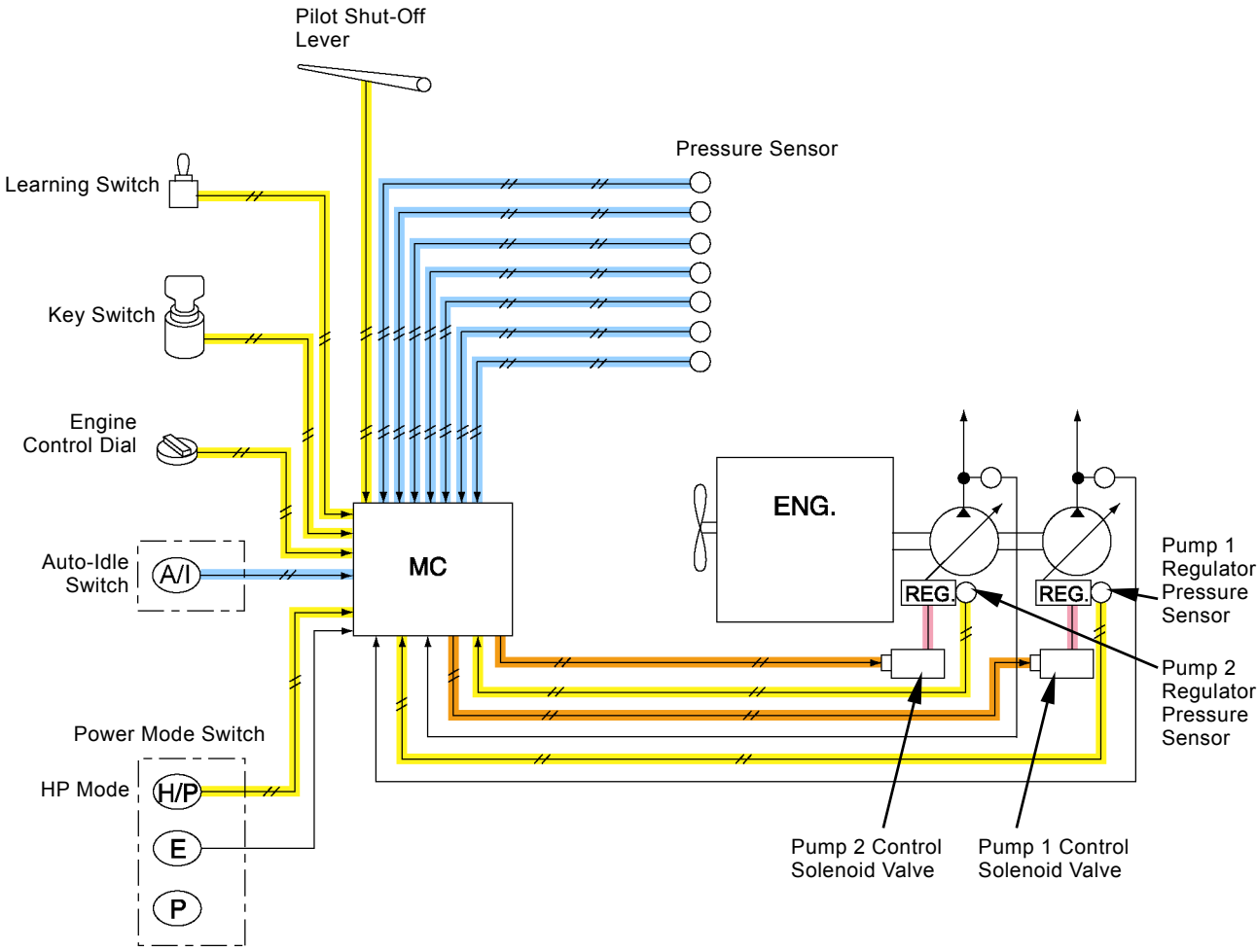

T1J1-02-02-033

## **SYSTEM / Control System**

---

### **VALVE CONTROL**

The valve control system functions as follows:

- Pressure Increase Selection Control When Traveling
- Power Digging Control
- Auto-Power Lift Control
- Travel Motor Swash Angle Control
- Boom Mode Selector Control
- Boom Flow Rate Control Valve Control

# SYSTEM / Control System

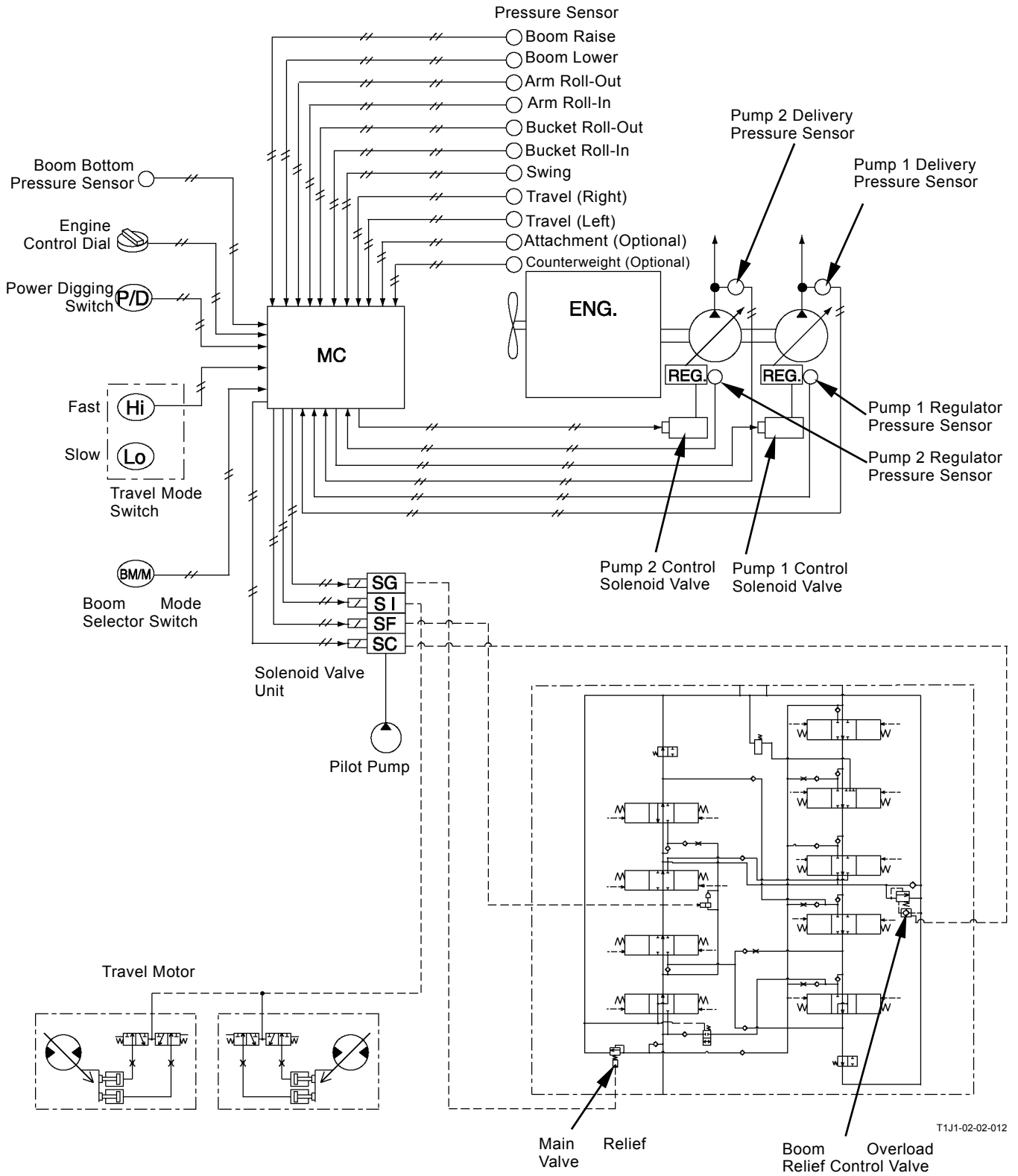

## SYSTEM / Control System

---

### Pressure Increase Selection Control When Traveling, Power Digging Control

Purpose: Applies back-pressure to the main relief valve and increases main relief pressure.

Operation:

1. When the pressure sensor (travel right or left) detects travel pilot pressure or when the power digging switch is turned in the ON position, MC activates solenoid valve unit (SG) (for eight seconds with the power digging switch ON).
2. Pressure oil from the pilot pump flows to the back of main relief valve.
3. Pressure oil compresses the spring of main relief valve and increases relief pressure. (Refer to the Control Valve group / COMPONENT OPERATION.)

 NOTE: Main Relief Pressure:

*During normal operation: 31.9 MPa(325 kgf/cm<sup>2</sup>)*

*During pressure increasing operation: 34.3 MPa(350 kgf/cm<sup>2</sup>)*

# SYSTEM / Control System

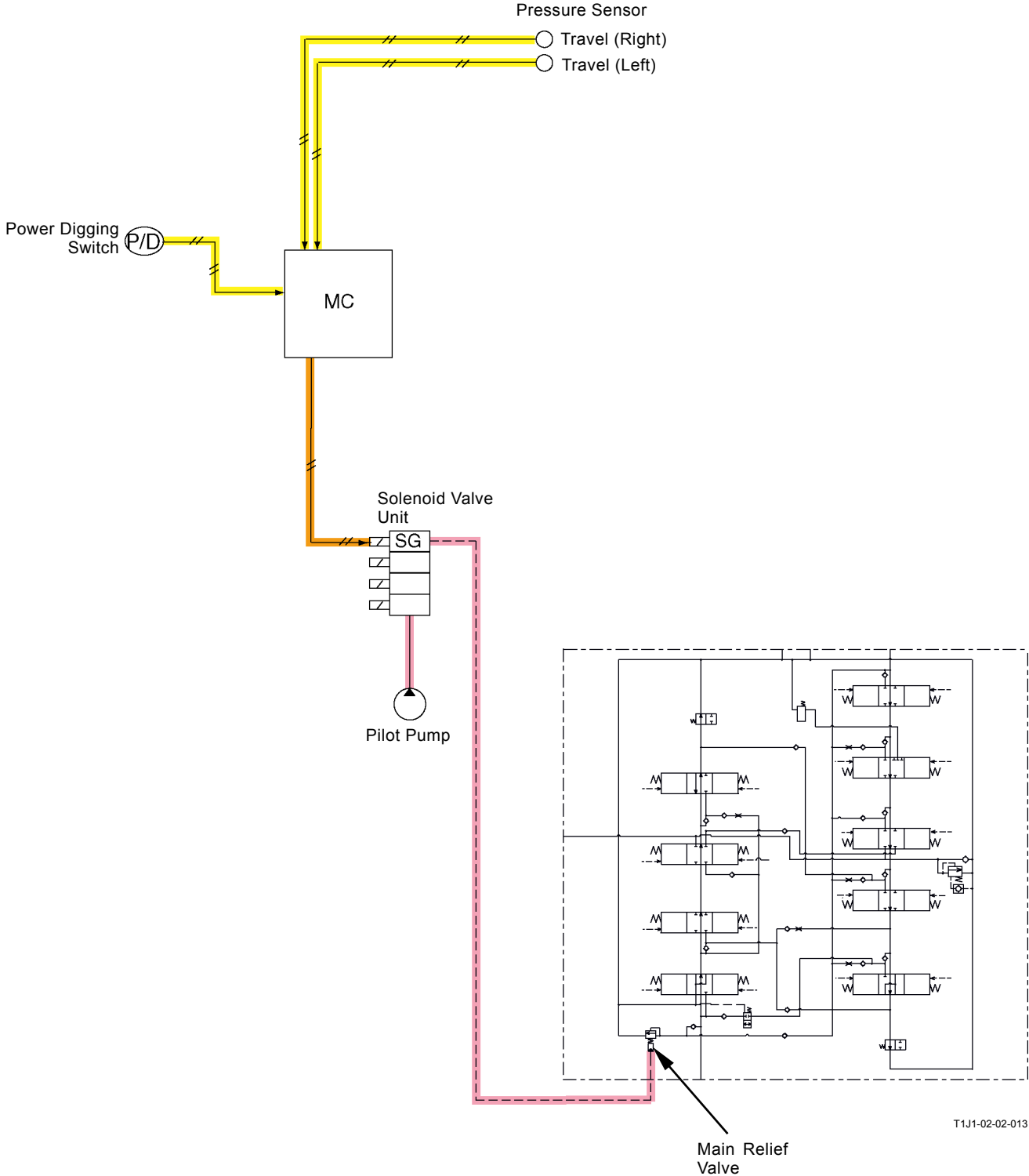

T1J1-02-02-013



## SYSTEM / Control System

---

### Auto-Power Lift Control

Purpose: Increases pressure when raising the boom.

Operation:

1. MC activates solenoid valve unit (SG) when the signals from pressure sensors (boom raise, arm roll-in) and pump 1 delivery pressure sensor meet the following conditions.
2. Pressure oil from the pilot pump flows to the back of main relief valve.
3. Pressure oil compresses the spring of main relief valve and increases relief pressure (Refer to the Control Valve group / COMPONENT OPERATION.)

Conditions:

- Boom Raise Pressure Sensor: Output 1.7 MPa (17 kgf/cm<sup>2</sup>, 247 psi) or higher
- Pump 1 Delivery Pressure Sensor: Output 29 MPa (295 kgf/cm<sup>2</sup>, 4220 psi)
- Arm Roll-In Pressure Sensor: Output zero. (0.5 MPa (5.1 kgf/cm<sup>2</sup>, 73 psi))

 **NOTE:** *This control system is activated during combined operations (except for the arm roll-in combined operation).*

# SYSTEM / Control System

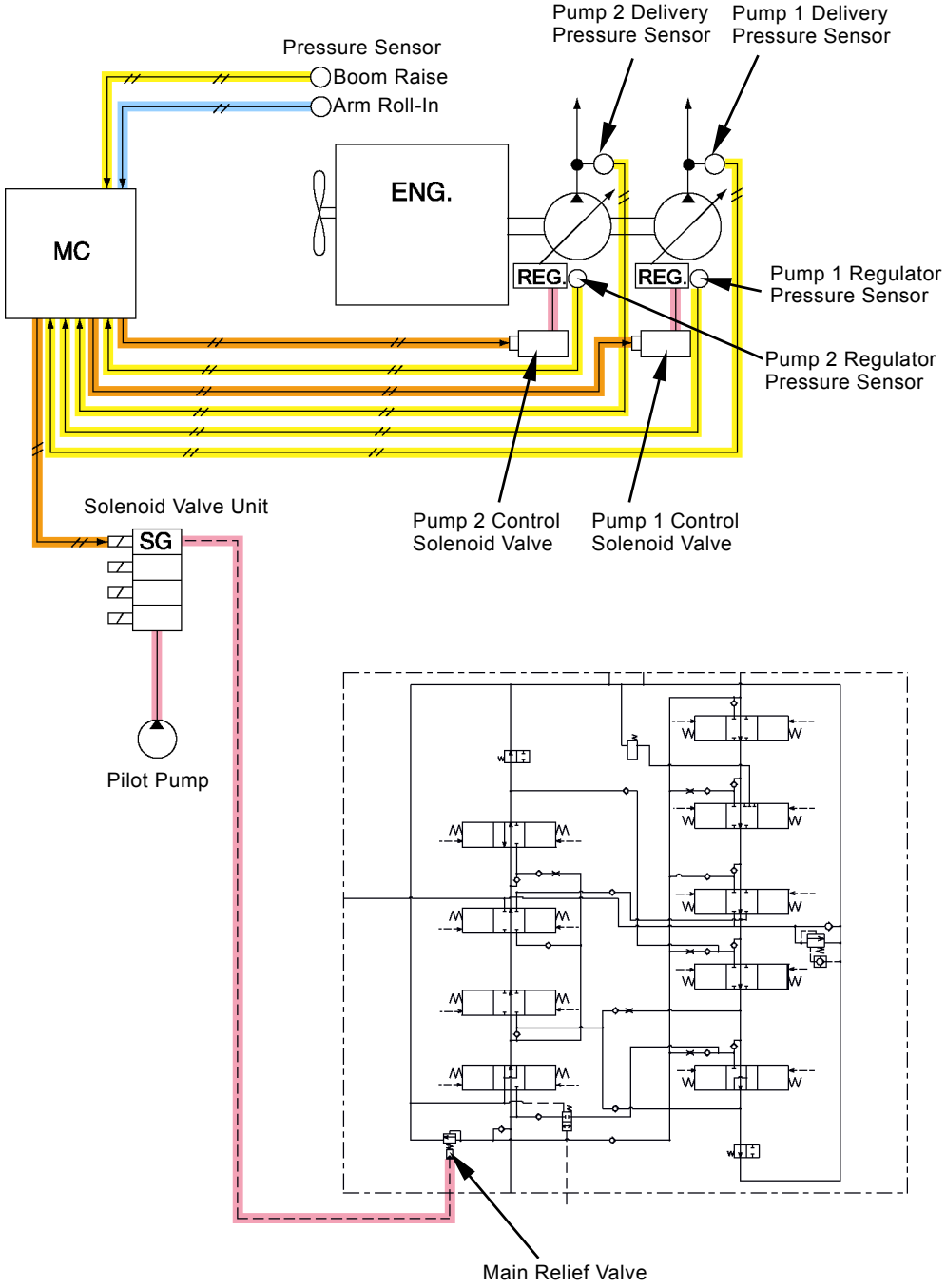

T1J1-02-02-015

## SYSTEM / Control System

### Travel Motor Swash Angle Control

Purpose: Selects the travel mode.

Operation:

- Slow Travel Mode
1. With the travel mode switch the  (SLOW) position, no electrical current flows to solenoid valve unit (SI).
  2. As solenoid valve unit (SI) is not activated (shifted), pressure oil from the pilot pump is not supplied to the travel mode selection valve.
  3. For this reason, the travel mode selection valve is not shifted, and pressure oil in the travel circuit in control valve is not supplied to the tilt pistons. Consequently, the travel motors rotate in the slow speed mode.  
(Refer to the Travel Device group / COMPONENT OPERATION.)

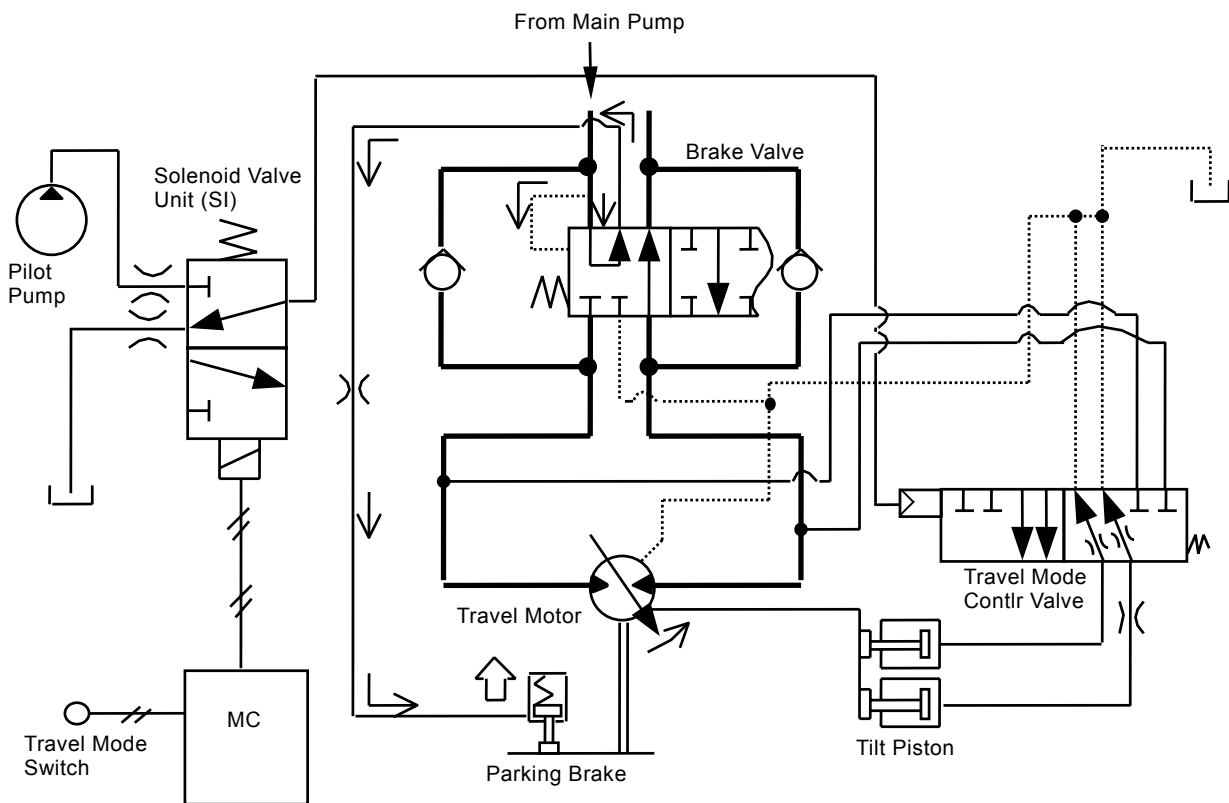

## SYSTEM / Control System

- Fast Travel Mode
1. With the travel mode switch turned to the  (FAST) position, electrical current flows to solenoid valve unit (SI).
  2. As solenoid valve unit (SI) is activated (shifted), pressure oil from the pilot pump is supplied to the travel mode selection valve.
  3. For this reason, pressure oil in the travel circuit in control valve is supplied to the tilt pistons. Consequently, the travel motors rotate in the fast speed mode.  
(Refer to Travel Device group / COMPONENT OPERATION.)

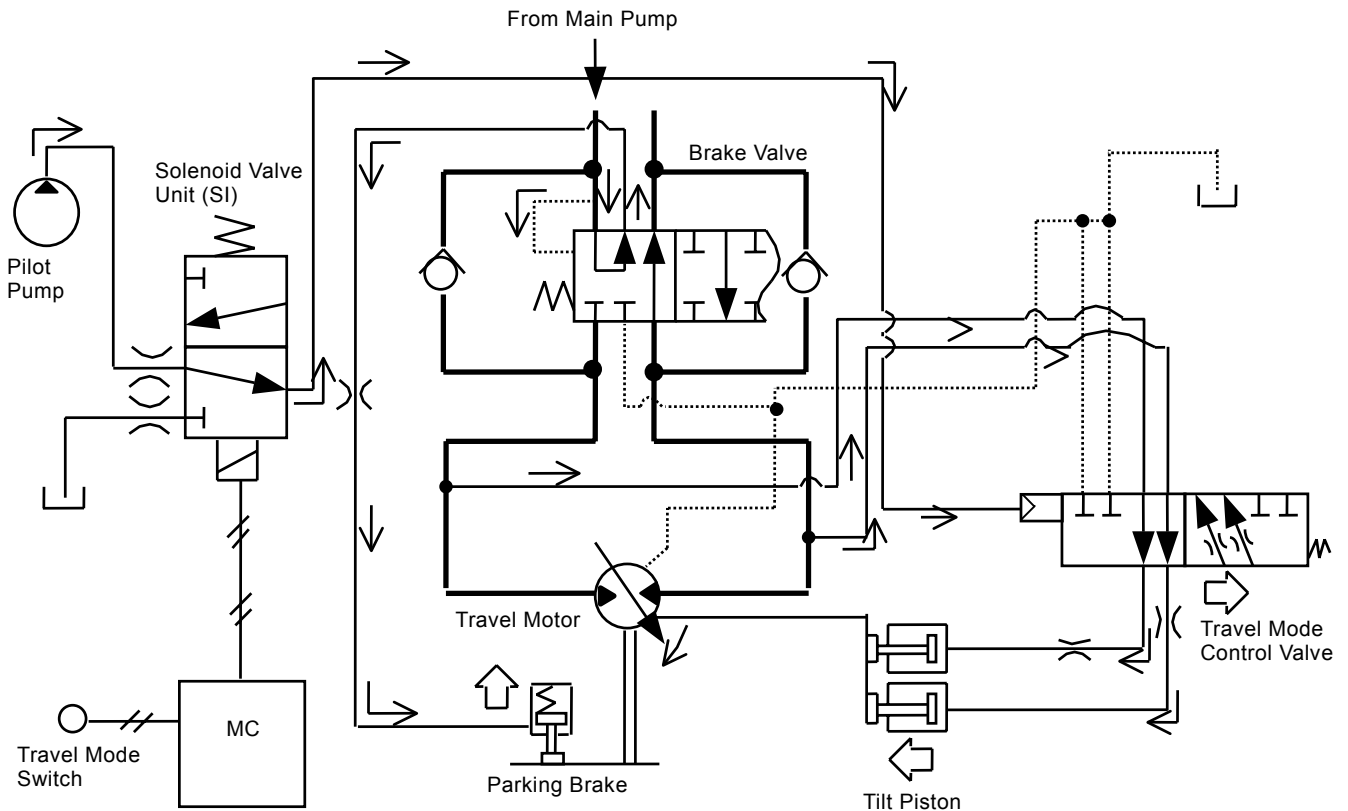

## SYSTEM / Control System

---

### Boom Mode Selector Control

Purpose: Reduces vibration of the machine at digging and grading work.

Operation:

1. The signals from each pressure sensor are sent to MC.
2. When the following conditions exist, MC activates solenoid valve unit (SC).
3. Pressure oil from the pilot pump flows through solenoid valve unit (SC) and acts on the boom overload relief control valve.
4. When the boom overload relief control valve is shifted, relief set pressure of the overload relief valve decreases.
5. Consequently, as holding pressure at the boom cylinder rod side decreases, vibration of the machine is reduced during boom lower operation. (Refer to the Control Valve group, Boom Overload Control Valve group / COMPONENT OPERATION.)

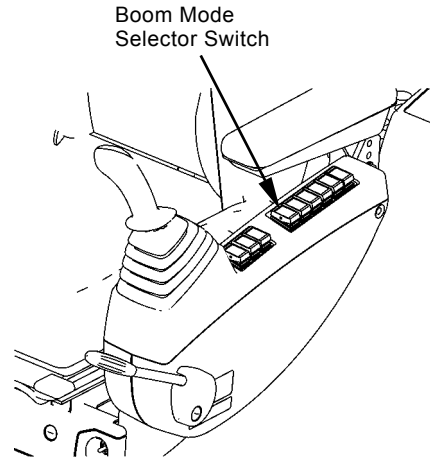

M1J1-03-001

Condition:

- Work Mode: Digging mode
- Boom Mode Selector Switch: ON
- Pressure Sensor (Travel Right/Left) No output
- Pressure Sensor (Boom, Arm, Bucket, Swing and Attachment): Output from either pressure sensor

 **NOTE:** *Overload Relief Pressure:*  
*During normal operation: 35.3 MPa (360 kgf/cm<sup>2</sup>) @110 L/min*  
*During operation: 11.8 MPa (120 kgf/cm<sup>2</sup>) @110 L/min*

 **NOTE:** *When output of each pressure sensor (boom raise/lower, arm roll-out/in, bucket roll-out/in, swing, travel right/left, attachment (optional) or counterweight (optional)) becomes 0.7 MPa (7.1 kgf/cm<sup>2</sup>, 102 psi) or higher, MC recognizes that the control lever is operated.*

# SYSTEM / Control System

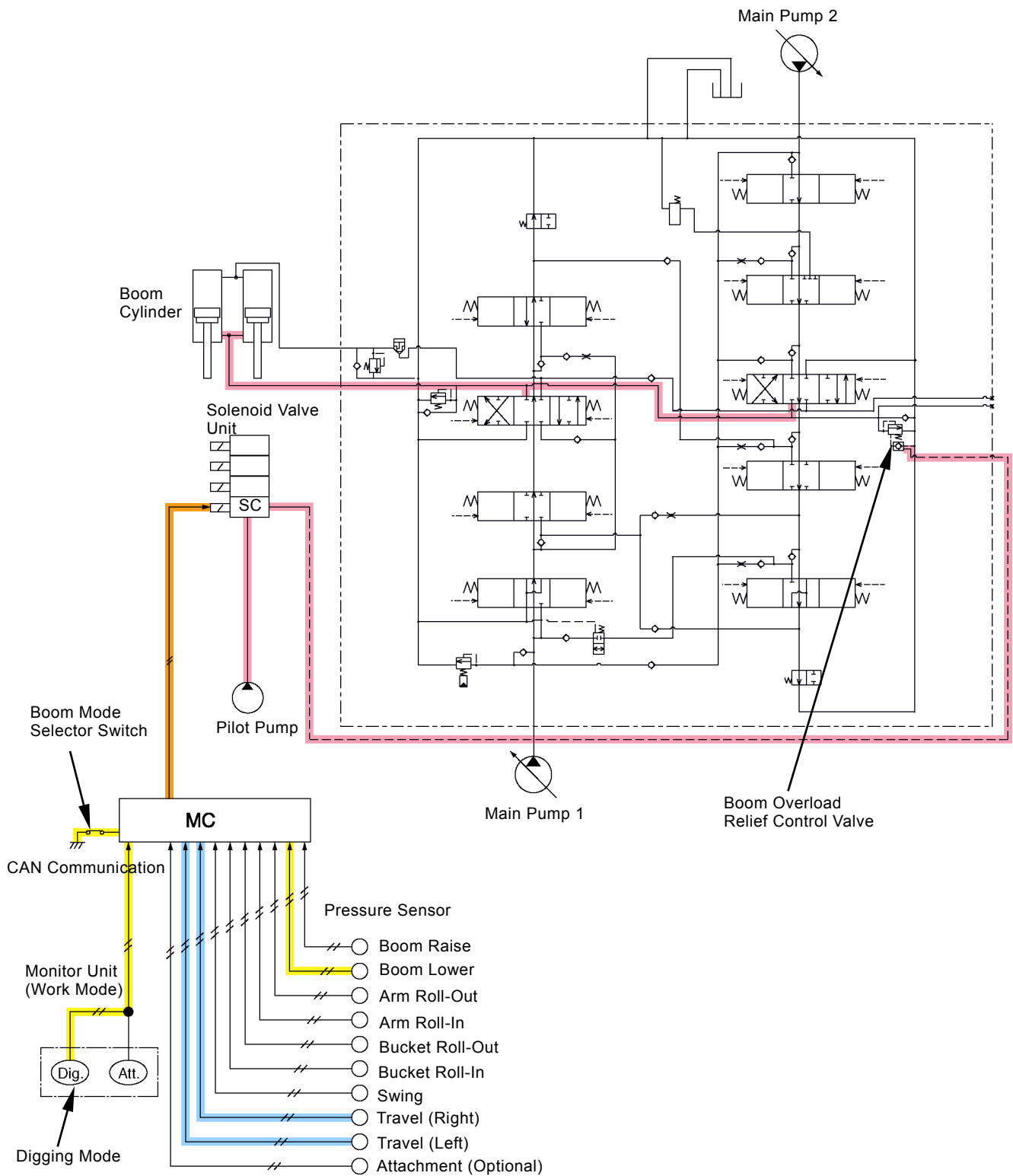

T1J1-02-02-016

**NOTE:** The illustration shows during boom lower operation.

## SYSTEM / Control System

---

### Boom Flow Rate Control Valve Control

Purpose: Restricts pressure oil to the boom cylinder from the pump during combined operation of boom lower and arm or boom lower and bucket.

When the boom is lowered due to own weight with the regenerative circuit and pressure oil from the pump is used for other actuator, operating speed of actuator increases.

(Refer to the Control Valve group / COMPONENT OPERATION.)

Operation:

1. When the pressure sensor sends the signal to MC during combined operation of boom lower and arm or boom lower and bucket, MC activates solenoid valve unit (SF).
2. Pressure oil from the pilot pump acts on the switch valve in boom flow rate control valve.
3. Therefore, the switch valve in boom flow rate control valve is shifted and pressure oil which flows to the boom cylinder from the pump is restricted.
4. Consequently, pressure oil from the pump flows to the actuator and operating speed of actuator increases.

# SYSTEM / Control System

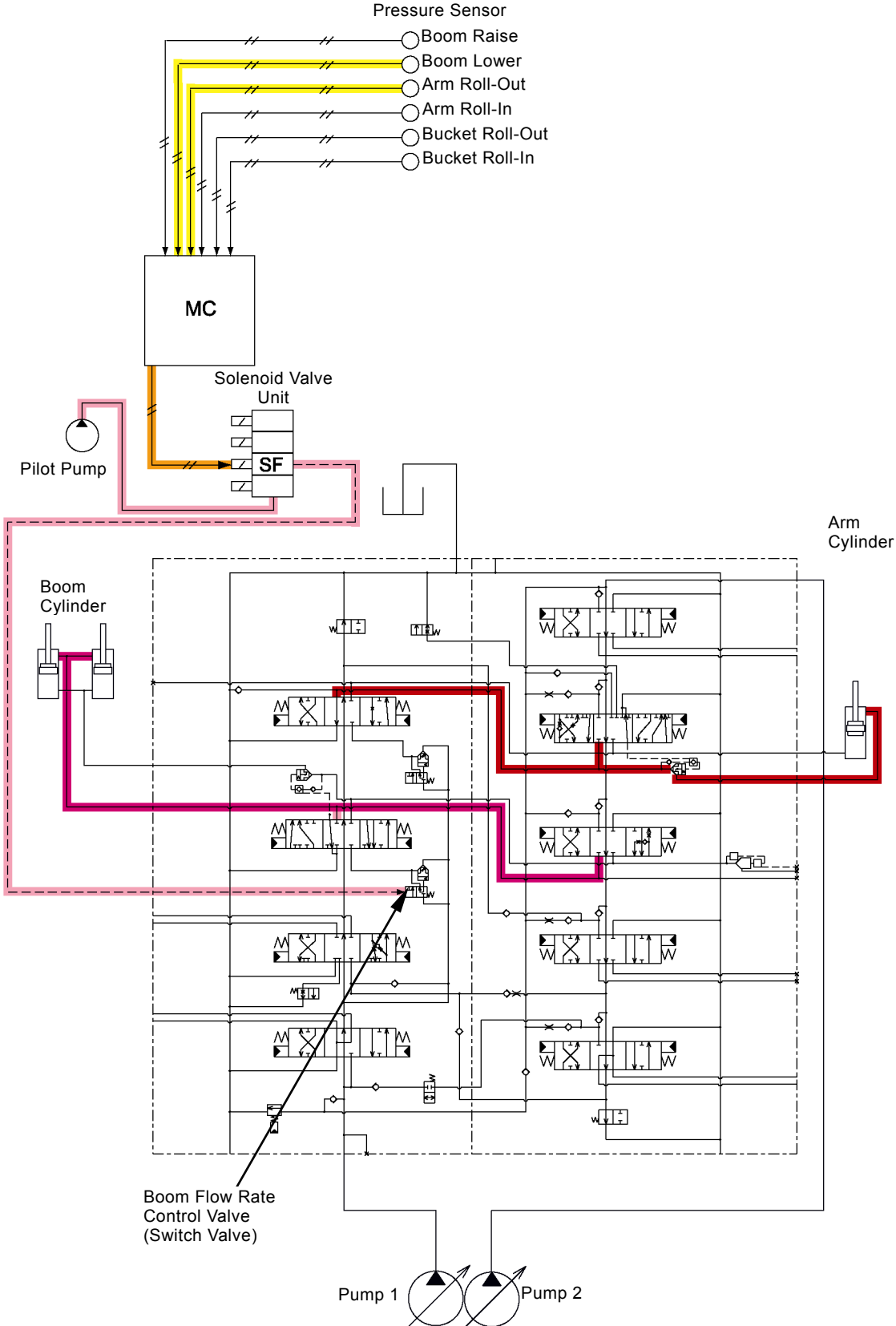

**NOTE:** The illustration shows during combined operation of boom lower and arm roll-in.

T1J1-02-02-017



## **SYSTEM / Control System**

---

### **OTHER CONTROLS**

The valve control system functions as follows:

- Work Mode Control
- Rear Monitoring Display Selection Control
- Level Check Control
- Auto Lubrication Control (Optional)
- Travel Alarm Control (Optional)
- Overload Alarm Control (Optional)

## SYSTEM / Control System

---

### Work Mode Control

The work mode consists of two modes, digging and attachment.

The mode can be selected by using the monitor unit.

- Digging Mode:  
Normal control is performed.
- Attachment Mode:  
Functions only when a front attachment in the optional kit is operated.  
Flow rate of the pump increases or decreases in proportion to control pressure of the auxiliary valve (refer to T2-2-34).  
The pump flow rate control settings are made by using the monitor unit and Dr. ZX.

## SYSTEM / Control System

---

### Rear View Image Selection Control

Purpose: Changes the display of monitor unit into the image of rearview monitor.

Operation:

1. When the signal from travel pressure sensor or rear view switch (optional) is sent to MC, MC sends the signal to select the display to the monitor unit by using CAN communication.
2. Monitor unit changes the display into the image of rearview monitor.
3. Push the rearview monitor selection switch on monitor unit and change the image of rearview monitor.

 **NOTE:** *The function of image selection on monitor unit can be turned OFF in the setting menu.*

# SYSTEM / Control System

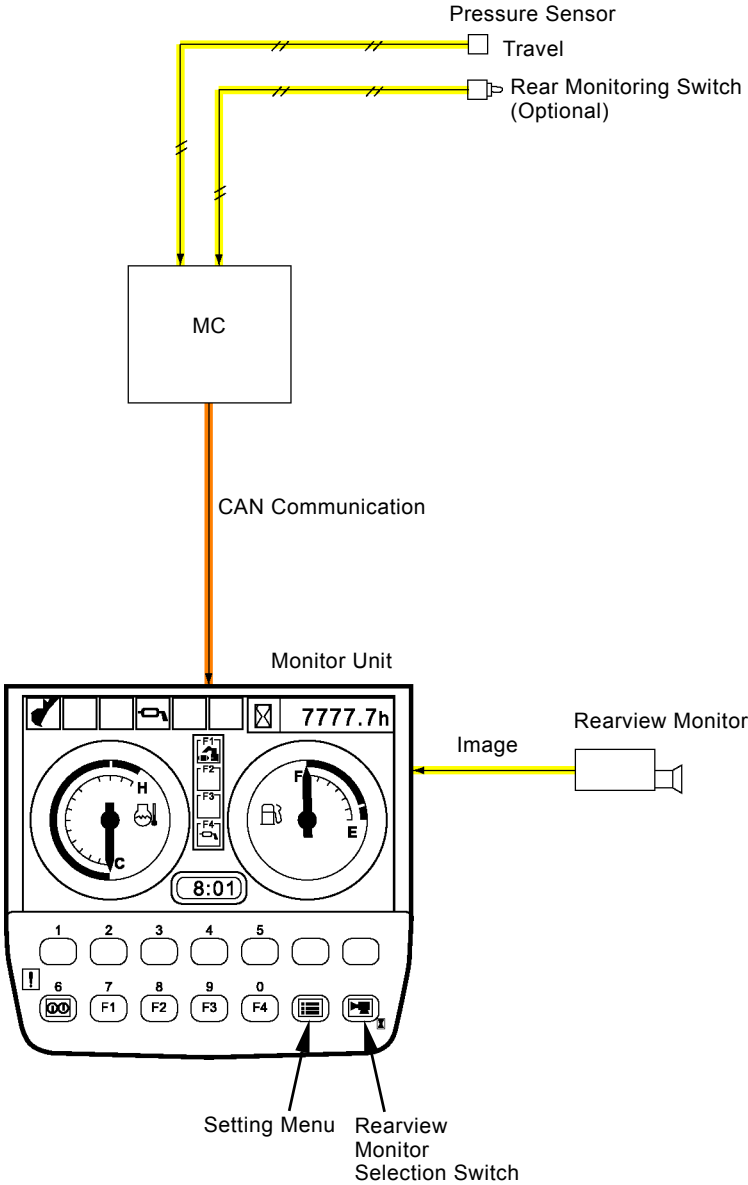

T1J1-02-02-036

## SYSTEM / Control System

---

### Level Check Control

Purpose: Checks levels of coolant and engine oil when starting the work. This result is displayed on the monitor unit.

#### Operation:

1. When the level check switch is turned ON with the key switch ON, MC receives the signal.
2. MC outputs the signals of coolant level switch and engine oil level switch to the monitor unit.
3. The monitor unit displays the coolant level and engine oil level.

 **NOTE:** *Display Color to Monitor Unit:*  
*During normal: Green*  
*During lack: Red*

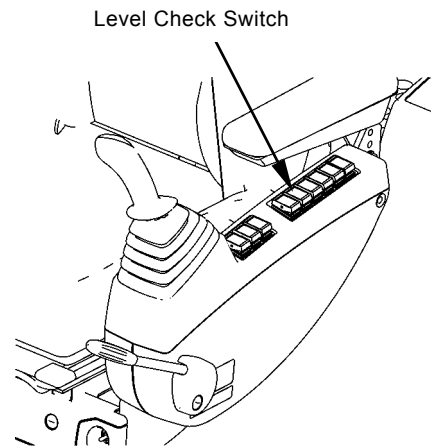

M1J1-03-001

# SYSTEM / Control System

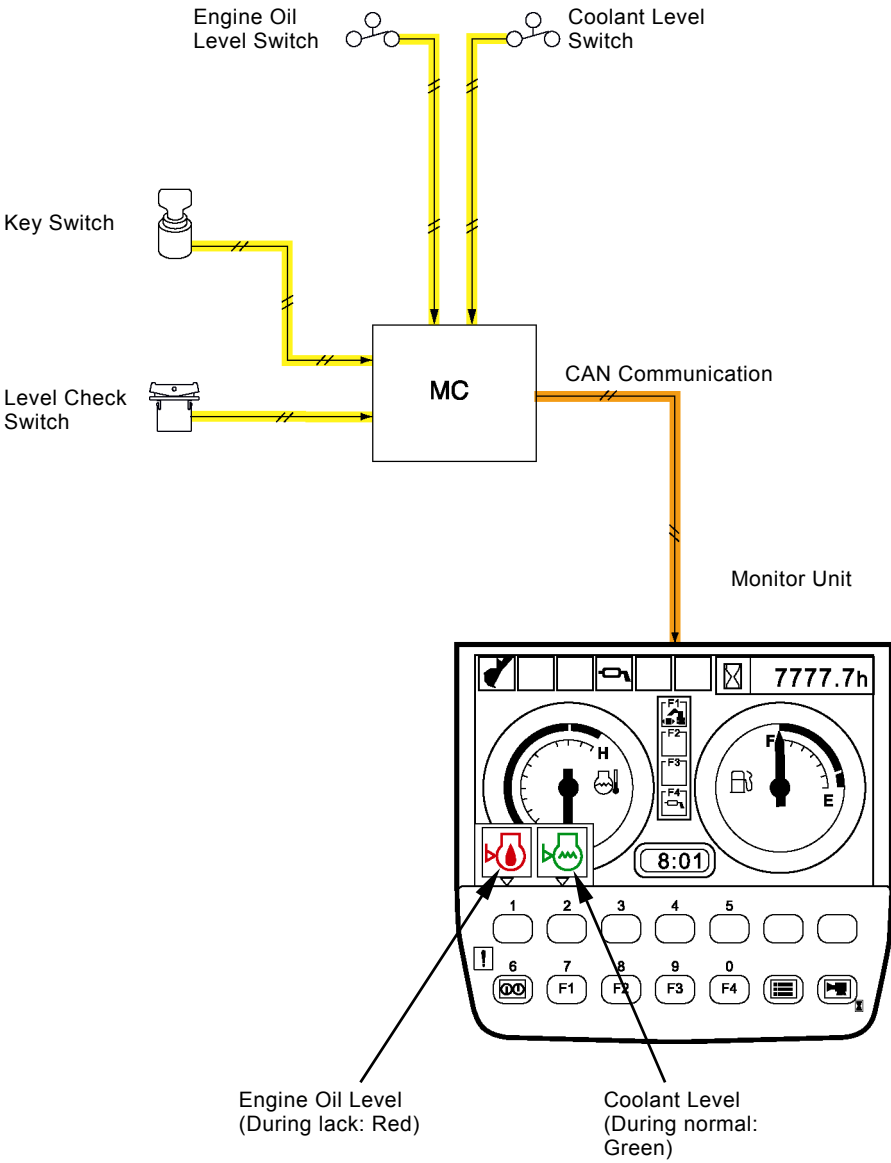

T1J1-02-02-035

## SYSTEM / Control System

### Auto Lubrication Control (Optional)

Purpose: Controls the auto lubrication system correctly.  
(Refer to the Others (Upperstructure) group,  
distribution valve group / COMPONENT  
OPERATION.)

#### Operation:

1. When the auto lubrication switch is turned ON, terminal B24 is connected to the ground inside MC.
2. Therefore, auto lubrication relay (R11) is excited.
3. Electrical current from fuse #30 flows to terminal #3 in the grease pump and proximity switch.
4. Therefore, the grease pump is activated and auto lubrication starts.
5. While auto lubrication relay (R11) is turned ON, the grease pump is activated and delivers grease.
6. When the grease pump delivers grease, the piston in distribution valve is operated.
7. The proximity switch is provided in distribution valve and is turned ON or OFF by the piston stroke of distribution valve.
8. When the piston of distribution valve comes up to the proximity switch, the proximity switch is turned ON and the transistor in proximity switch is turned ON. Therefore, terminal #B5 in MC is connected to the ground via the proximity switch.
9. In opposite, when the piston of distribution valve becomes away from the proximity switch, the proximity switch is turned OFF and the transistor in proximity switch is turned OFF. Therefore, electrical current from terminal #3 flows to terminal #B5 in MC.
10. MC detects operating number (stroke number) of distribution valve according to the signal input to terminal #B5.
11. When operating number (stroke number) reaches the setting, MC blocks the grounding connection of terminal #B24.
12. Consequently, auto lubrication relay (R11) is turned OFF and no electrical current flows to the grease pump, so that the grease pump stops.
13. After the preset interval, MC activates the grease pump and starts auto lubrication in order to connect terminal #B24 to the ground.
14. Within five minutes after auto lubrication relay (R11) is turned ON, if the signal from the proximity switch is not sent to terminal #5 in MC, MC recognizes that the auto lubrication circuit is faulty (no grease, faulty grease pump). Then, the auto lubrication alarm is displayed on the monitor unit.

 **NOTE:** Lubrication time and interval can be set by using the monitor unit and the service mode in Dr.ZX.

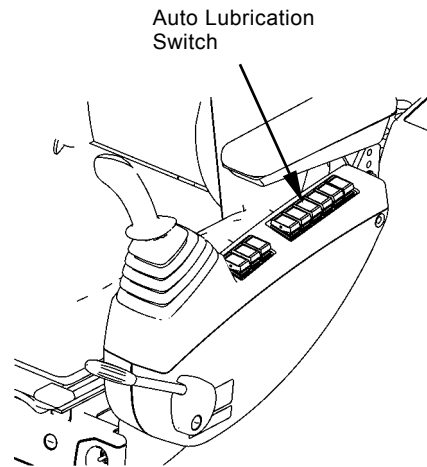

M1J1-03-001

# SYSTEM / Control System

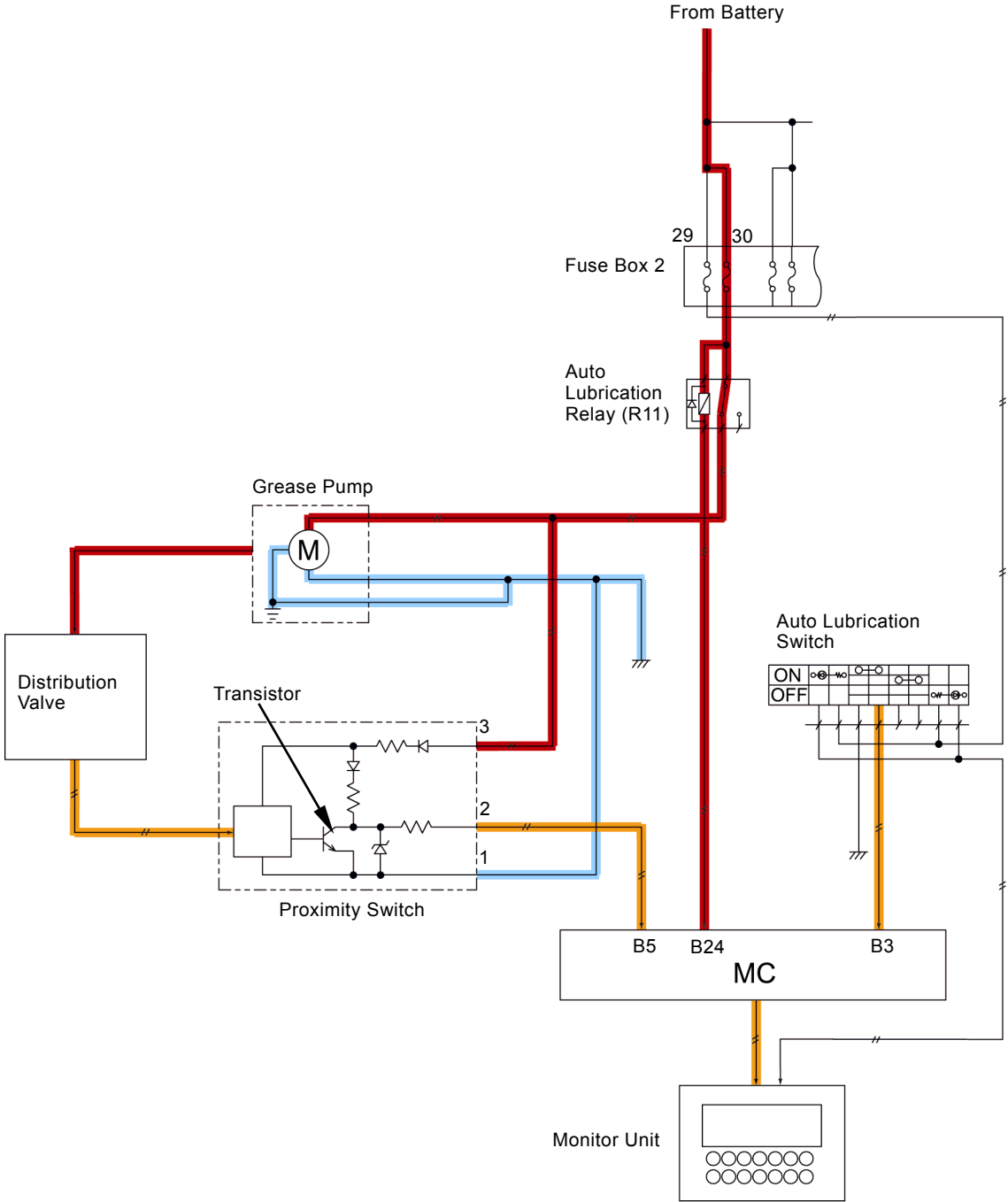

T1J1-02-02-020



# SYSTEM / Control System

## Travel Alarm Control (Only Machine Equipped with Optional Parts)

Purpose: Sounds the buzzer while traveling.

Operation: MC receives the signals from travel pressure sensor (travel right or left) when travel operation is made. As long as MC receives this signal, MC sends the signals to the travel alarm device and sounds the buzzer.

 **NOTE:** After traveling continuously for more than 13 seconds, the buzzer can be stopped by using the travel alarm deactivation switch.

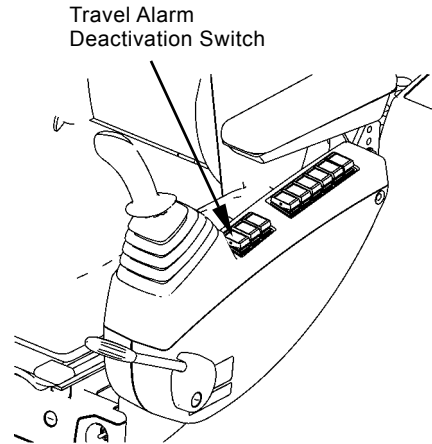

M1J1-03-001

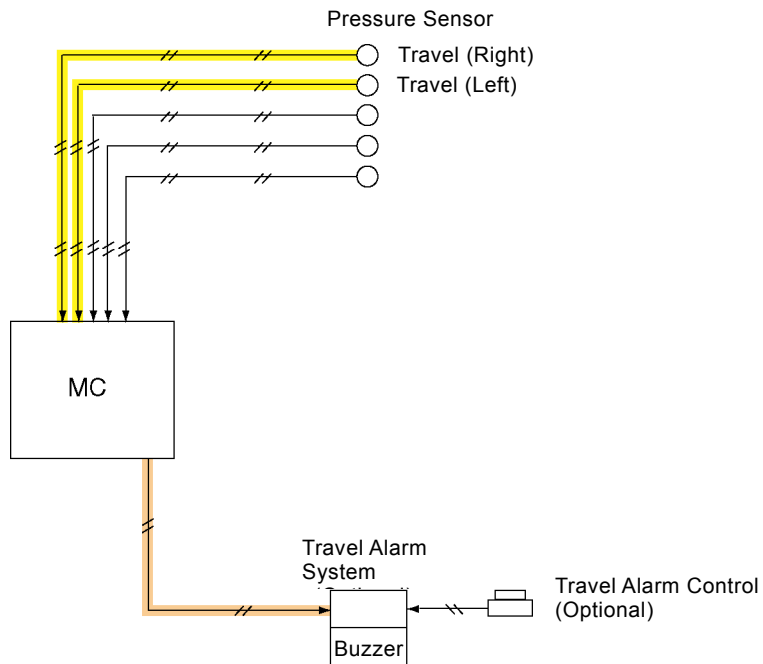

T1J1-02-02-018

# SYSTEM / Control System

## Overload Alarm Control (Only Machines Equipped with Optional Parts)

Purpose: Sounds the buzzer and indicates the warning of overload while overloaded operation of boom raise including lifting work.

 **NOTE:** The overload alarm in monitor unit should become enable by using Dr.ZX.

### Operation:

1. When the following conditions exist, MC sends the signal to the monitor unit.
2. While the monitor unit receives the signal from MC, terminal A9 is connected to the ground inside the monitor unit.
3. The monitor unit sounds the buzzer and indicates the warning of overload.

 **NOTE:** The pressure setting of overload alarm in MC can be adjusted by using Dr.ZX.

### Condition:

- Boom Bottom Pressure Sensor: Output beyond the constant value
- Overload Alarm Switch: ON

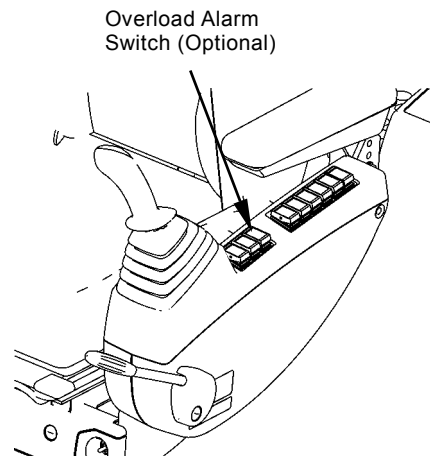

M1J1-03-001

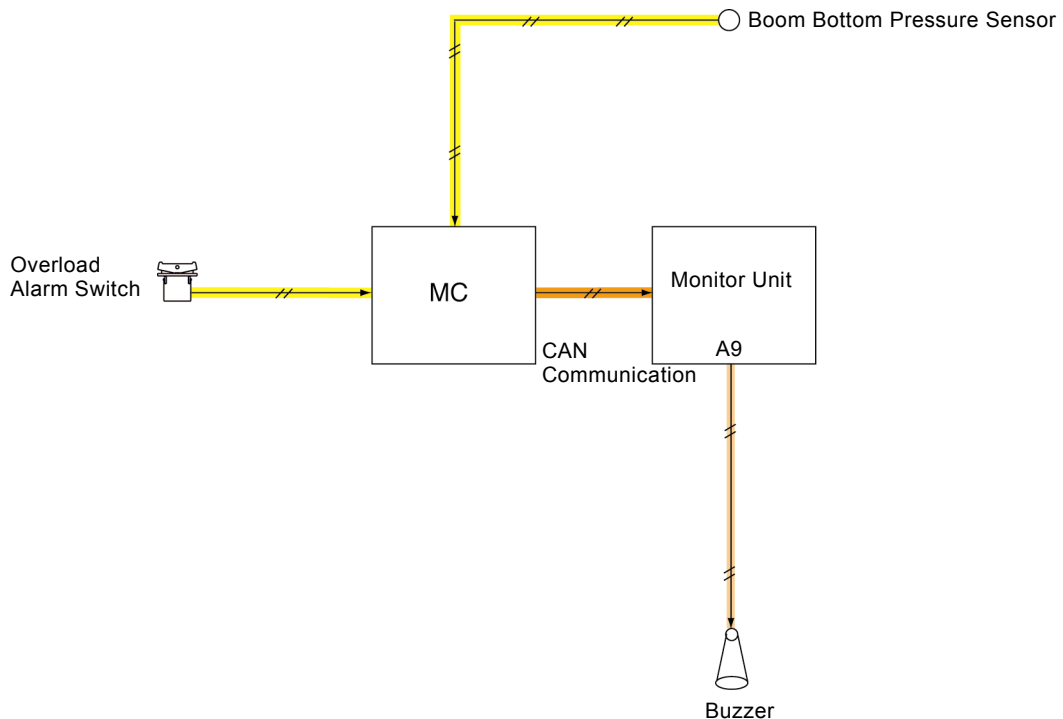

T1J1-02-02-019

## SYSTEM / Control System

---

(Blank)

# SYSTEM / ECM System

## OUTLINE

ECM (Engine Control Module) receives the signals from sensors and MC

ECM processes and drives the two-way valve, suction control valve and EGR (Exhaust Gas Recirculation) motor in order to control the supply pump, injector pump and EGR valve.

- Fuel Injection Control
- Fuel Injection Amount Correction
- Preheating Control
- EGR Control
- Engine Stop Control

- The supply pump is driven by the engine and produces high-pressure fuel.
- The common rail distributes high-pressure fuel produced by the supply pump to the injector in each engine cylinder.
- The injector injects high-pressure from the common rail.

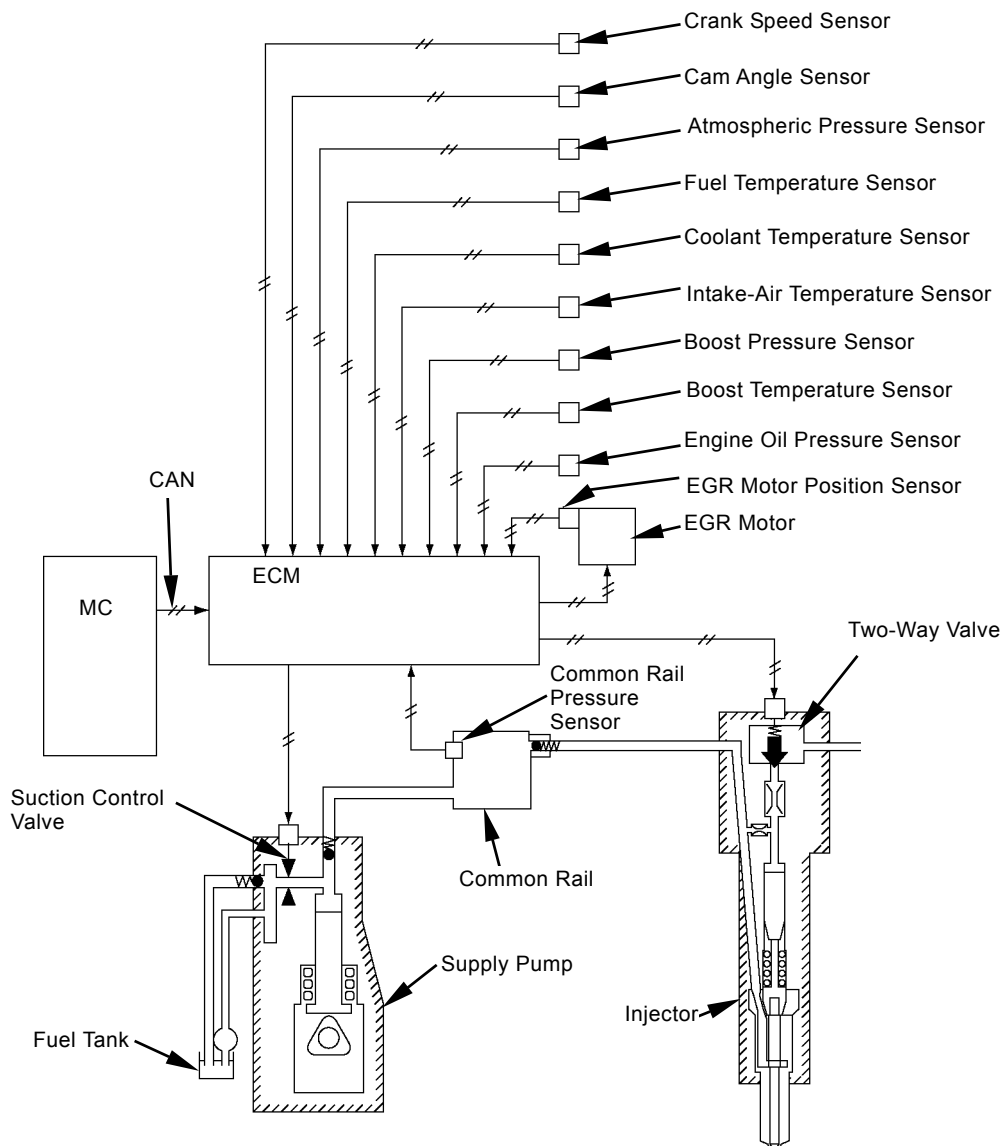

T1GR-02-02-001

## SYSTEM / ECM System

---

### FUEL INJECTION CONTROL

ECM detects the engine running condition according to the signals from each sensor and MC and controls fuel injection amount, injection pressure, injection timing and injection rate.

- Fuel Injection Amount Control
- Fuel Injection Pressure Control
- Fuel Injection Timing Control
- Fuel Injection Rate Control

 **NOTE:** *Two-way valve controls:*

- *Fuel Injection Amount Control*
  - *Fuel Injection Timing Control*
  - *Fuel Injection Rate Control*
- Suction control valve controls:*
- Fuel Injection Pressure Control

# SYSTEM / ECM System

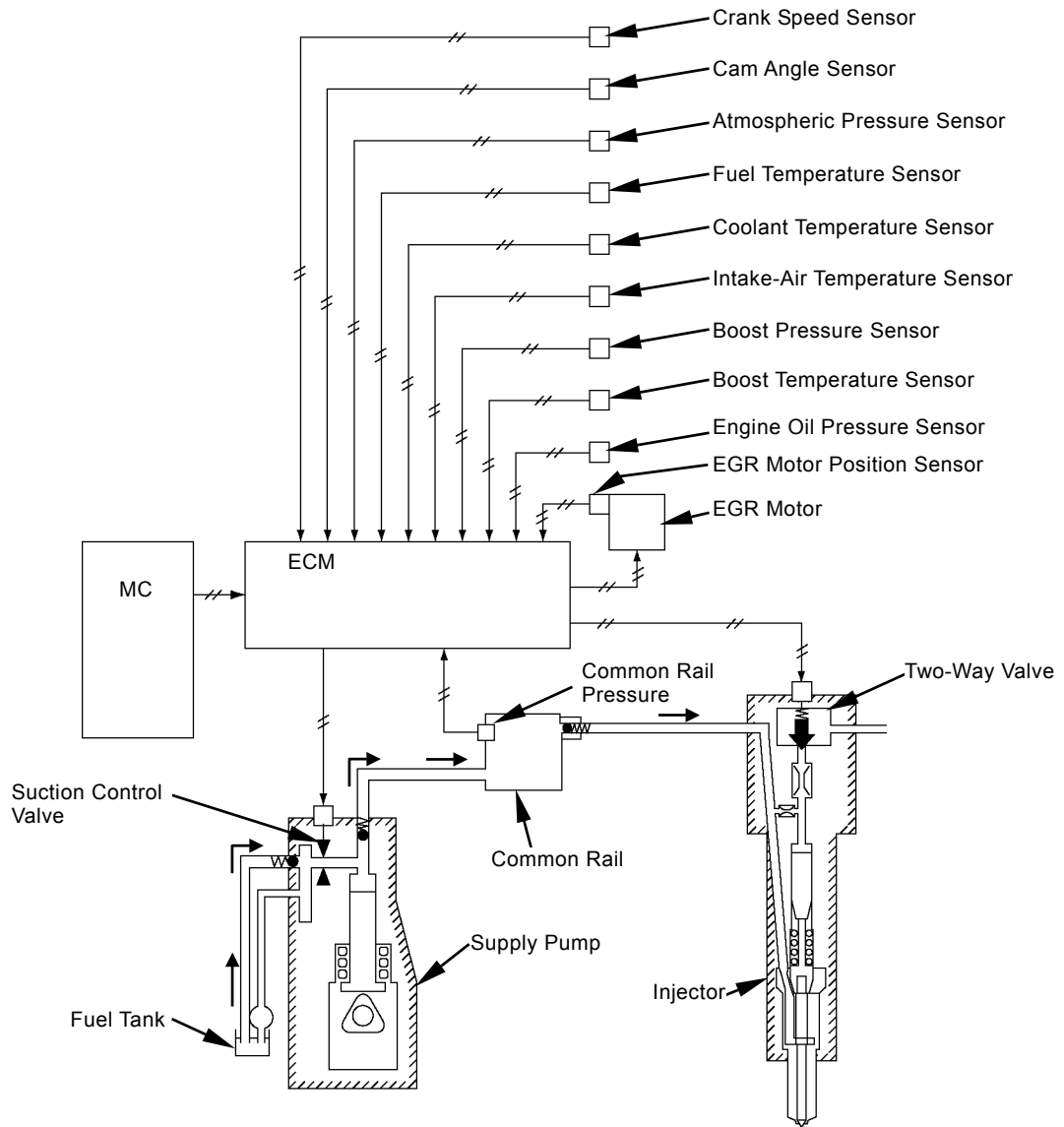

T1GR-02-02-001

## **SYSTEM / ECM System**

---

### **Fuel Injection Amount Control**

Purpose: Controls the best fuel injection amount.

Operation:

1. ECM detects the engine speed according to the signals from the crank speed sensor and cam angle sensor.
2. MC calculate the target engine speed according to the signals from the engine control dial, sensors and switches and sends the signals to ECM.  
(Refer to SYSTEM / Control System.)
3. ECM mainly controls fuel injection amount by turning ON/OFF for two-way valve in injector according to the engine speed and the signals from MC.

# SYSTEM / ECM System

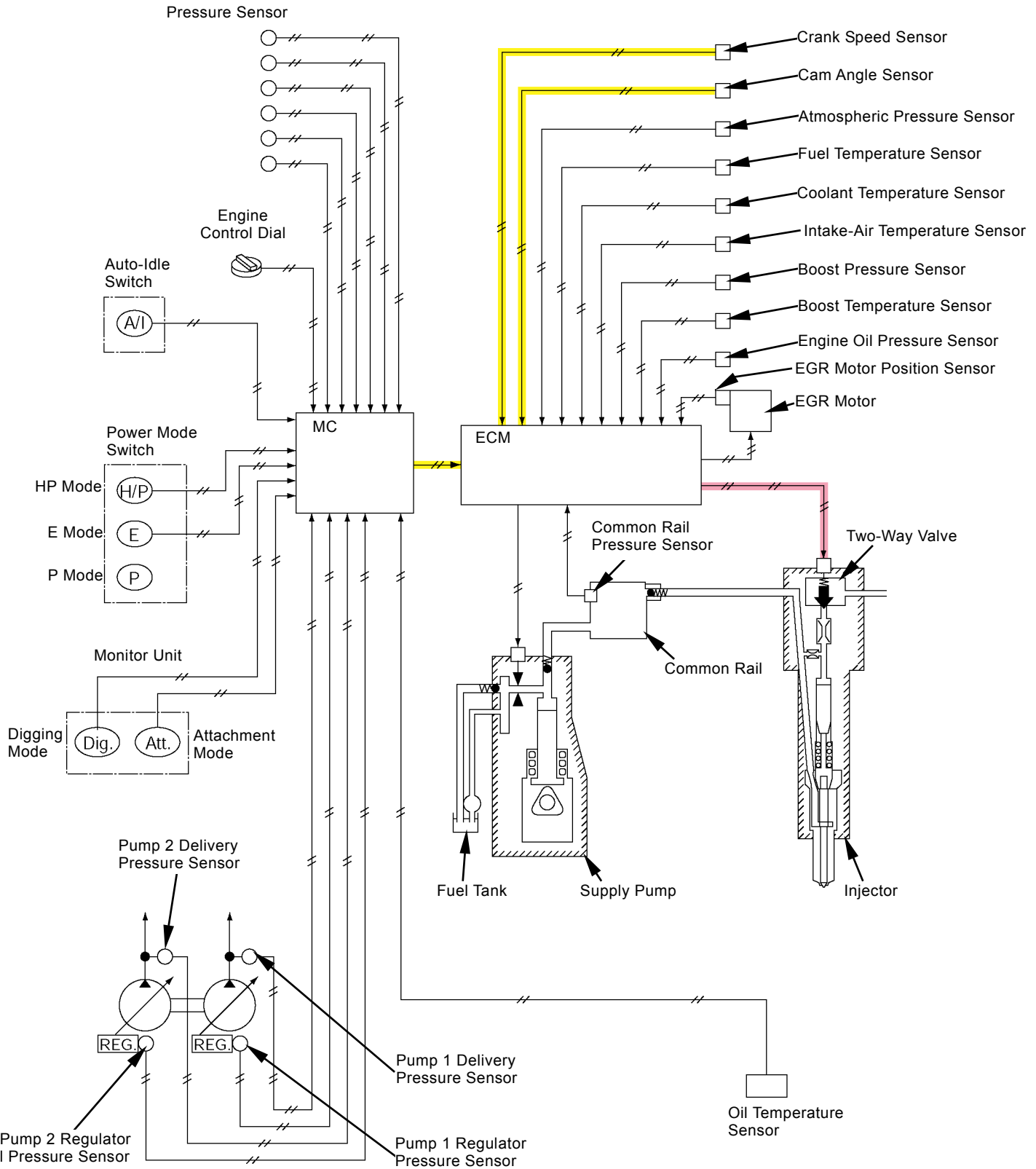

T1V1-02-02-001

**NOTE:** The illustration shows when sending the signal of target engine speed to ECM from MC.



## **SYSTEM / ECM System**

---

### **Fuel Injection Pressure Control**

Purpose: Controls fuel pressure in the common rail in order to control fuel injection pressure.

Operation:

1. ECM calculates fuel injection amount according to the engine speed and the signals from MC by using CAN communication. (Refer to the page on Fuel Injection Amount Control.)
2. The common rail pressure sensor sends the signals according to pressure in the common rail to ECM.
3. ECM calculates the best fuel pressure in common rail according to the engine speed, fuel injection amount and the signals of common rail pressure.
4. ECM drives the suction control valve in supply pump and supplies the best pressure of fuel to the common rail.
5. Fuel according to fuel pressure in the common rail is supplied to the injector from the common rail.

# SYSTEM / ECM System

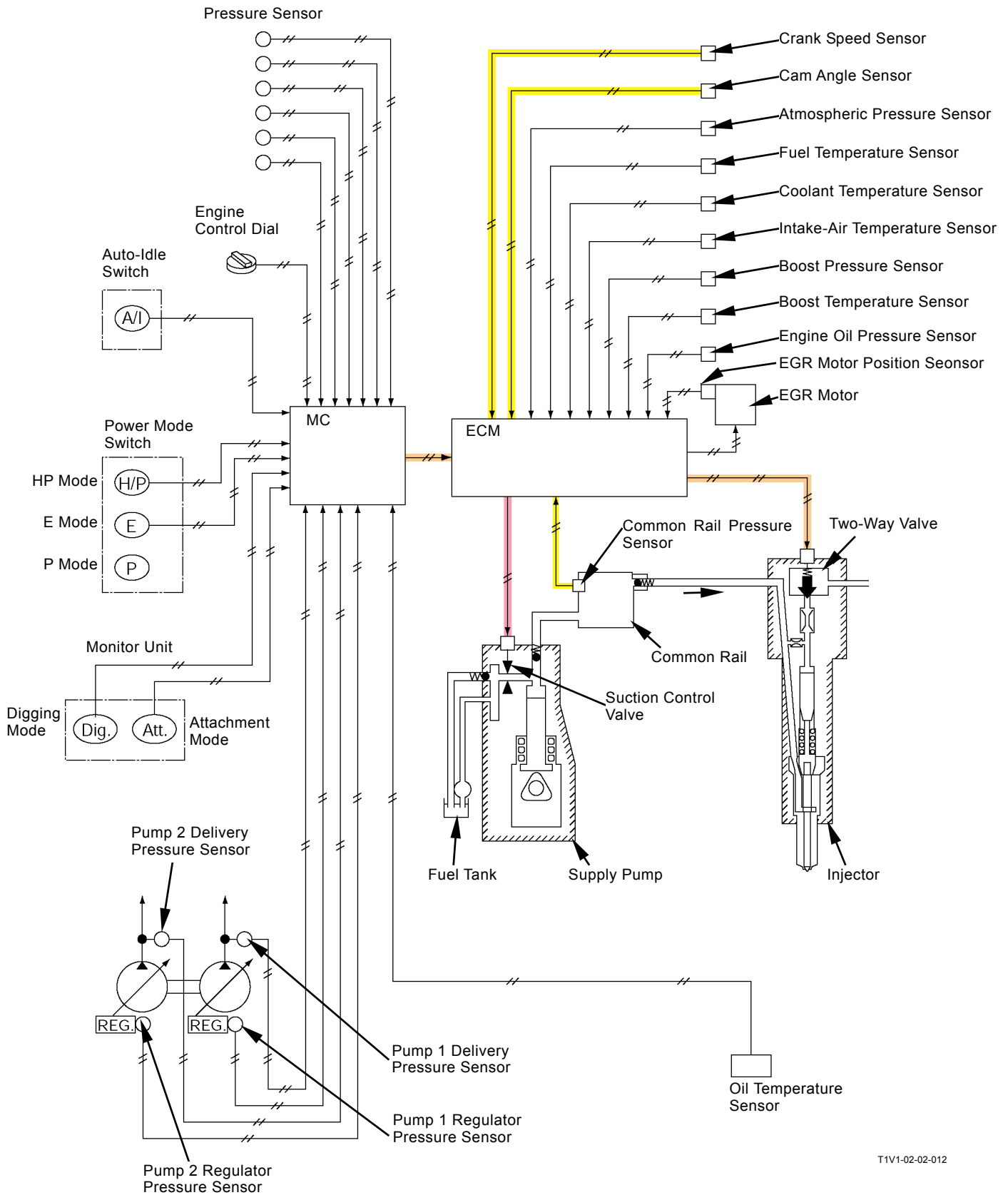

T1V1-02-02-012

## SYSTEM / ECM System

---

### Fuel Injection Timing Control

Purpose: Calculates the best fuel injection timing.

Operation:

1. ECM calculates the fuel injection timing according to engine speed and fuel injection amount.
2. ECM controls the two-way valve in injector by turning ON/OFF according to fuel injection timing.

### Fuel Injection Rate Control

Purpose: Improves combustion in the engine cylinder.

Operation:

1. The injector injects small amount of fuel (pilot injection) first and ignites.
2. After igniting, the injector injects fuel (main injection).
3. ECM controls fuel injection timing and fuel injection amount by turning the two-way valve in injector ON/OFF.

### Fuel Injection Operation

1. The nozzle in injector is always pressured.
2. When turning the two-way valve ON, high-pressure fuel in the control chamber flows through orifice 1.
3. Therefore, the hydraulic pressure piston is raised and the nozzle opens so that the injection starts.
4. When turning the two-way valve OFF, high-pressure fuel from the common rail flows to the control chamber through orifice 2.
5. Therefore, high-pressure flows to the control chamber and the hydraulic pressure piston is lowered.
6. Consequently, the nozzle is closed and injection stops.

# SYSTEM / ECM System

1. Two-Way Valve: ON

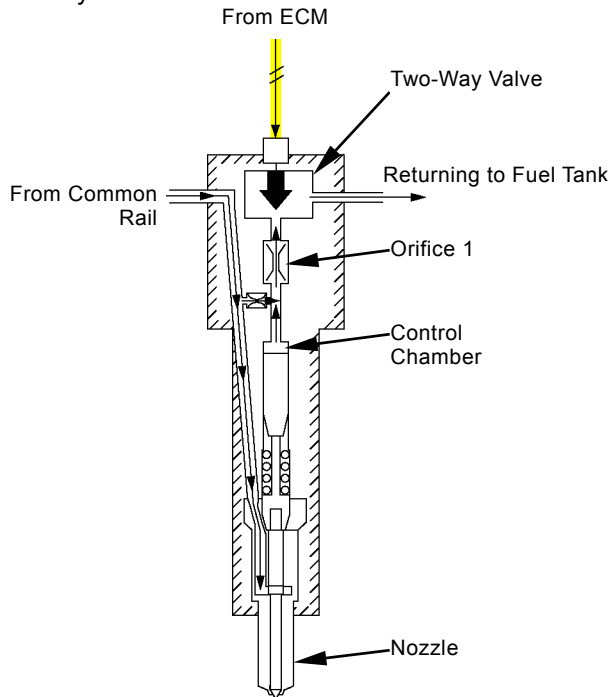

2. Injection Start

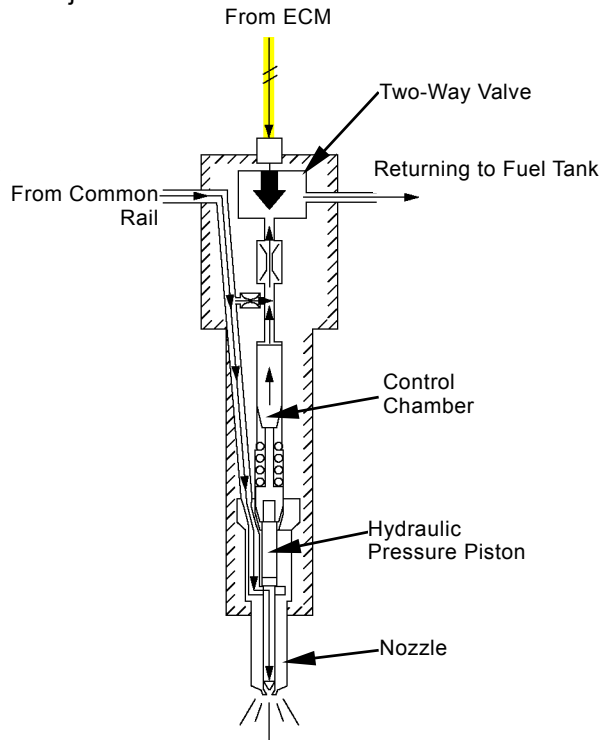

3. Two-Way Valve: OFF

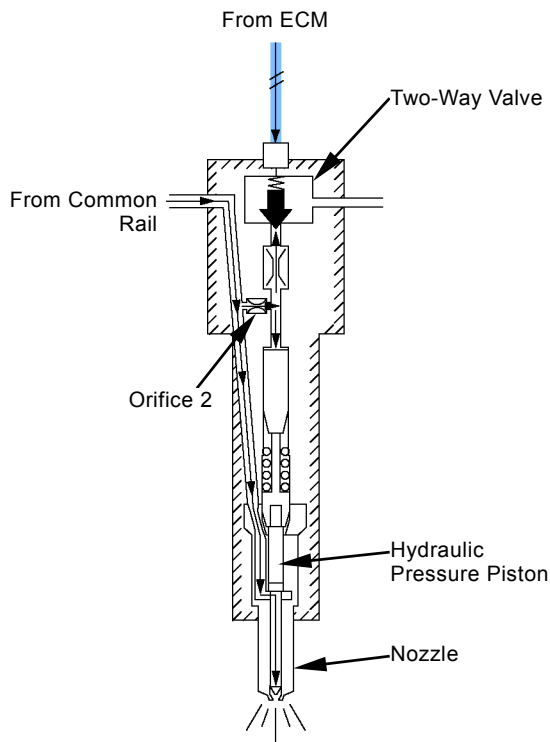

4. Injection Stop

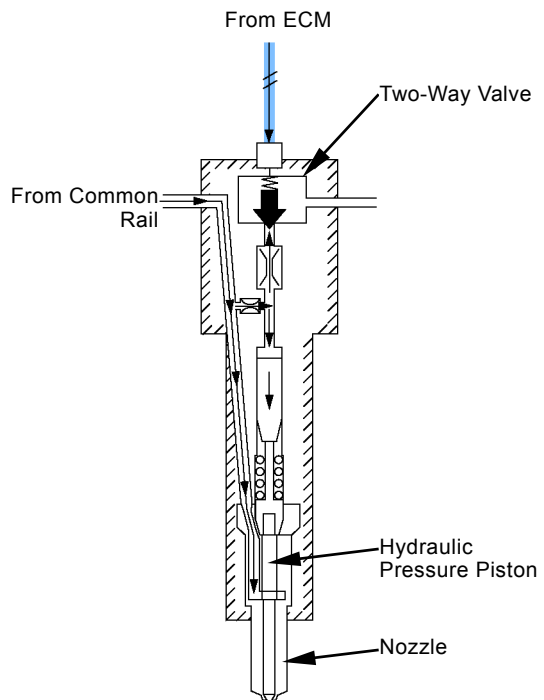

T1GR-02-02-012

# SYSTEM / ECM System

## FUEL INJECTION AMOUNT CORRECTION CONTROL

Purpose: Corrects fuel injection amount to the best fuel injection timing and amount.

1. When the engine starts and engine speed is lower than the engine start correction speed ( $550 \text{ min}^{-1}$ ), ECM corrects fuel injection amount. (Start Correction)
2. ECM corrects fuel injection amount according to the signals from the atmospheric pressure sensor. (High Altitude Correction)
3. ECM controls the two-way valve in injector and controls the best fuel injection amount.

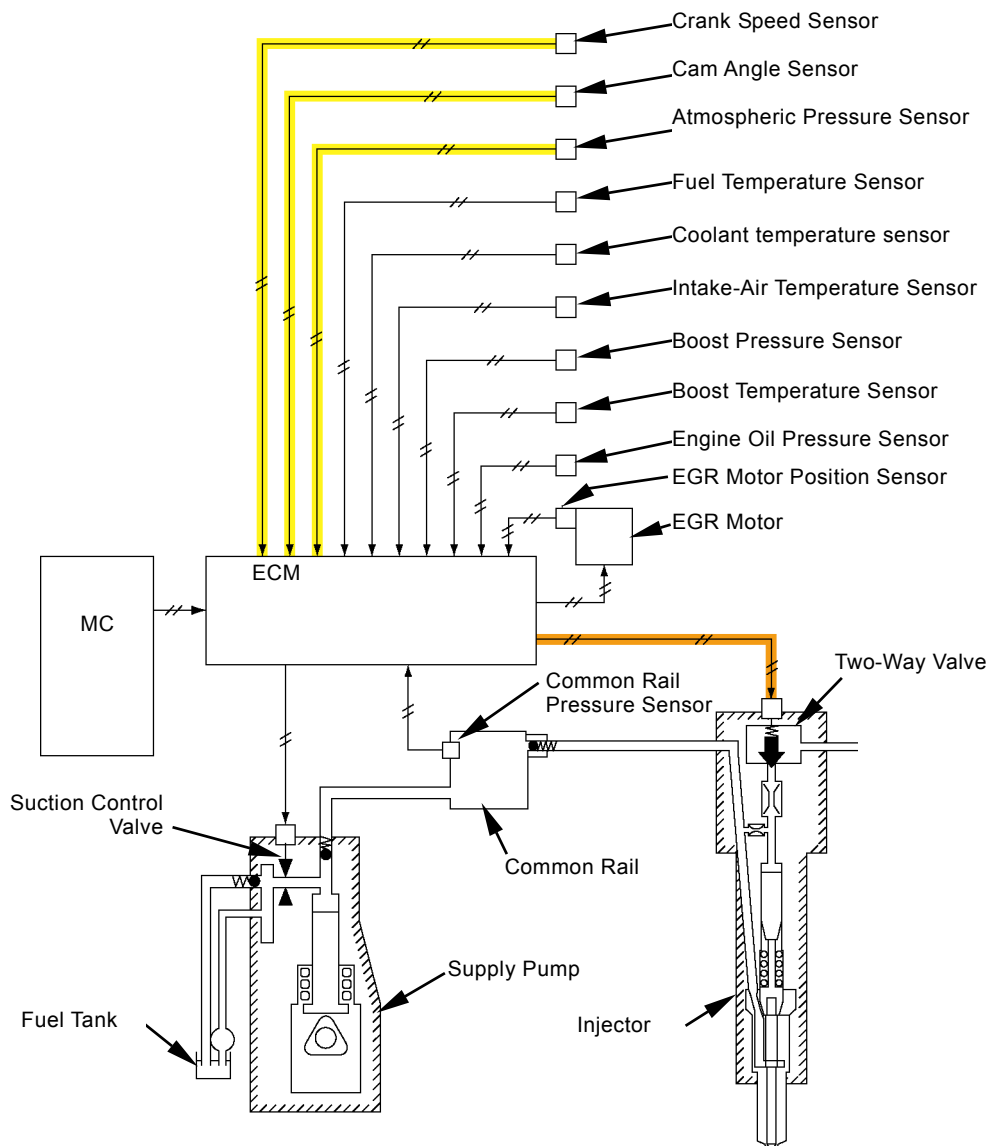

T1J1-02-03-003

## SYSTEM / ECM System

### PREHEATING CONTROL

Purpose: Warm the engine, makes the engine start, and reduces white smoke and noise when starting the engine. Preheats after the engine starts and makes idling immediately when the engine starts.

Operation:

1. The coolant temperature sensor sends the signals according to coolant temperature to ECM.
2. When the key switch is turned ON, electrical current from terminal M in the key switch flows to the glow relay.
3. ECM connects the ground circuit of glow relay according to the signals from coolant temperature sensor and controls time for continuity of electrical current for the glow plug.

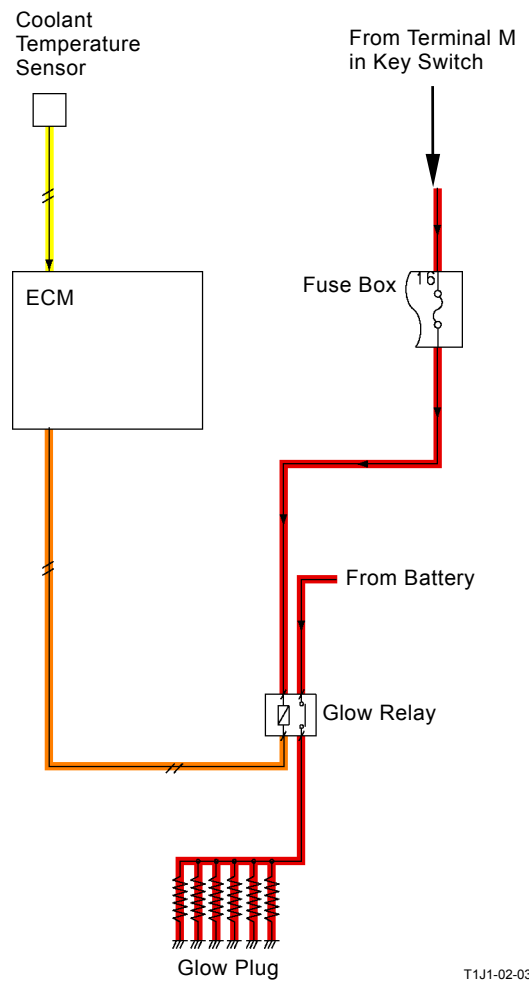

T1J1-02-03-002

## SYSTEM / ECM System

---

### EGR (EXHAUST GAS RECIRCULATION) CONTROL

Purpose: Re-circulates a part of exhaust gas in the intake manifold and combines it with intake-air. Therefore, combustion temperature is lowered and generation of oxide of nitrogen (NOx) is controlled.

Operation:

- EGR Gas Amount Control

1. ECM decides EGR gas amount according to engine speed, fuel flow rate, coolant temperature, atmospheric pressure and intake-air temperature.
2. ECM drives EGR motor, opens EGR valve and exhausts EGR gas in response to engine condition so that EGR gas is combined with intake-air.
3. At the same time, ECM detects the opening amount of EGR valve by using EGR motor position sensor.

- EGR Gas Cooling

1. EGR gas is cooled by the cooling system in EGR gas passage.
2. Cooled EGR gas is combined with intake-air so that combustion temperature is lowered and NOx is generated lower.

- Lead Valve

1. The lead valve prevents fresh air from entering into the EGR gas passage and EGR gas from flowing in reverse direction.
2. Therefore, EGR gas flows to one direction and EGR gas amount increases.

# SYSTEM / ECM System

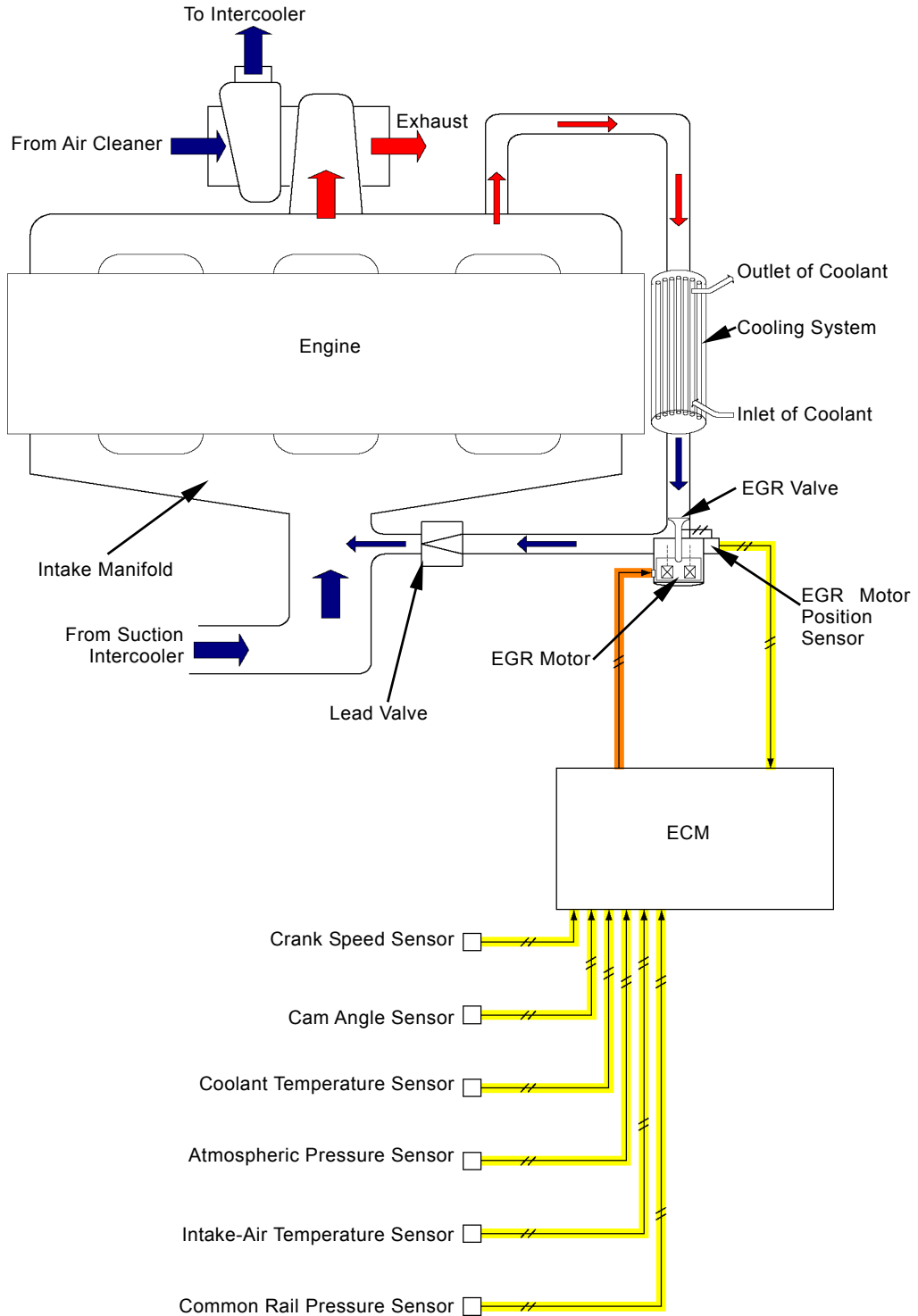

T1V1-02-02-007



## SYSTEM / ECM System

---

### ENGINE STOP CONTROL

Although the keys witch is turned to OFF, the engine does not stop. (Emergency Stop)

When the engine does not stop due to some troubles that the machine is broken or damaged with the key switch OFF, turn (lower) the engine stop switch to the ON position. Then, the engine stops. After that, return (raise) the engine stop switch to the OFF position.



**CAUTION: Do not use the engine stop switch except when unavoidable. When the machine stops due to the machine breakdown, do not start the machine until repair is completed.**

1. When the engine stop switch is turned to the ON position, electrical current from fuse #18 flows to terminal #V47 in ECM.
2. ECM stops fuel injection of the injector and stops the engine.
3. At the same time, ECM turns the ECM main relay OFF.
4. After the ECM main relay is turned OFF, ECM is turned OFF.

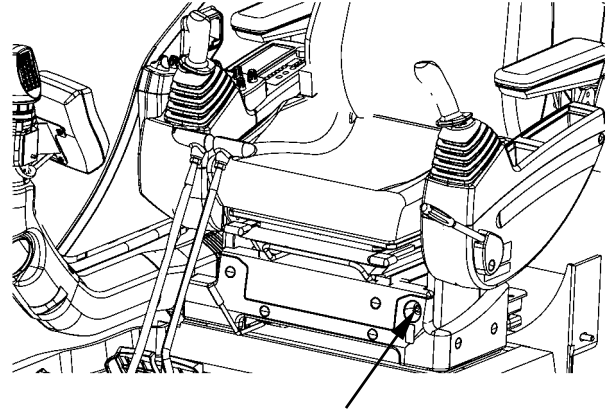

Engine Stop Switch

T1J1-02-03-004

# SYSTEM / ECM System

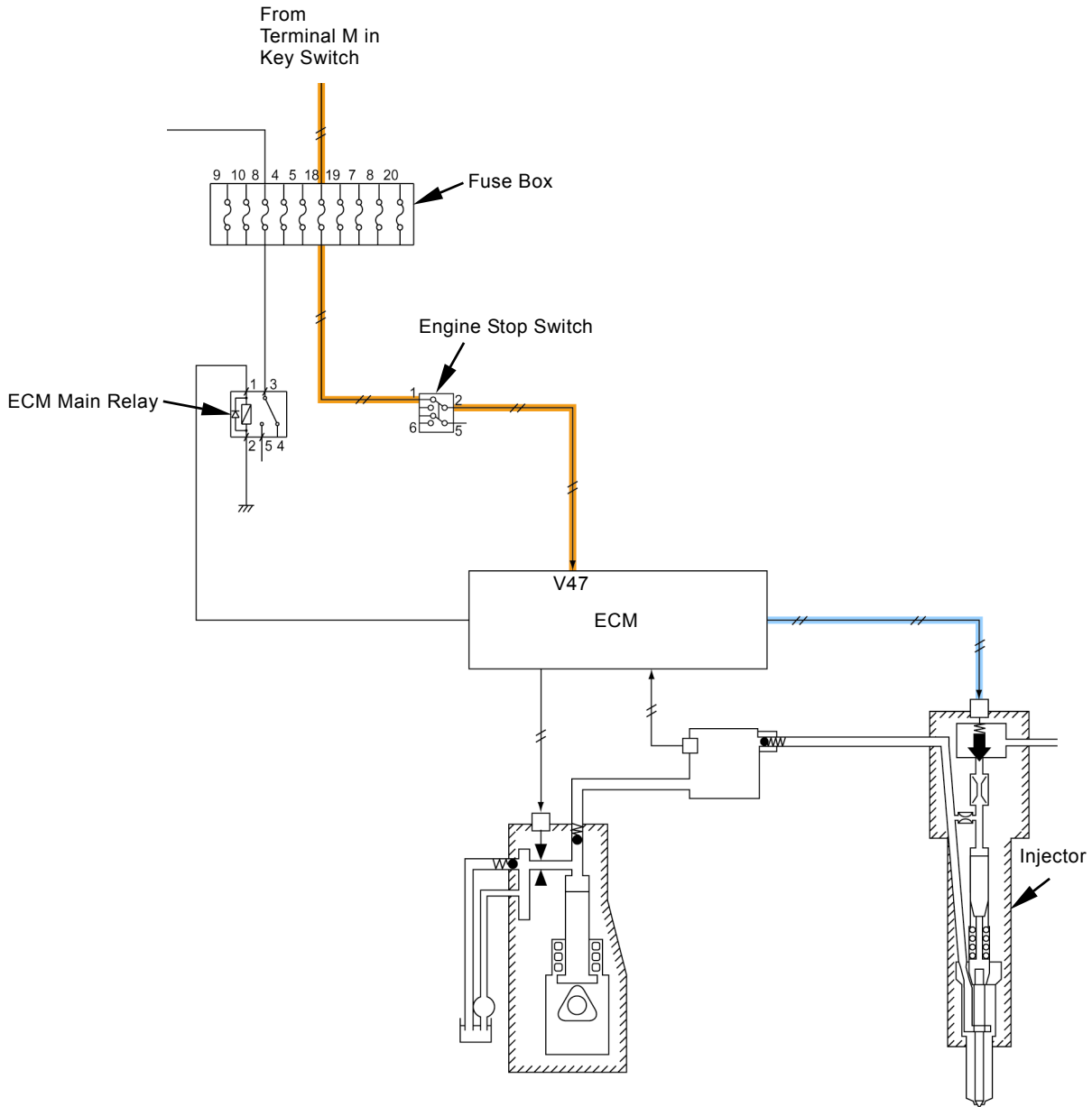

T1J1-02-03-001

## SYSTEM / ECM System

---

(Blank)

# SYSTEM / Hydraulic System

---

## OUTLINE

The hydraulic system is broadly divided into two circuits, the main circuit and the pilot circuit.

Pilot Circuit:

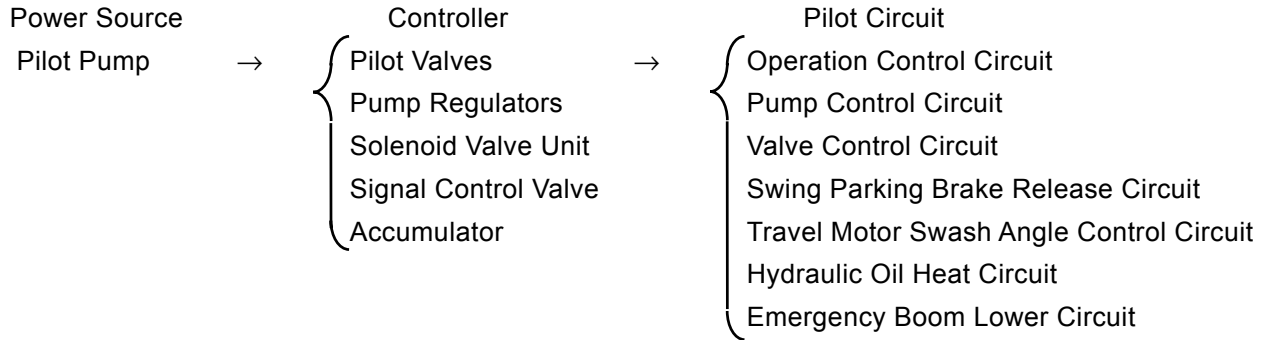

Main Circuit:

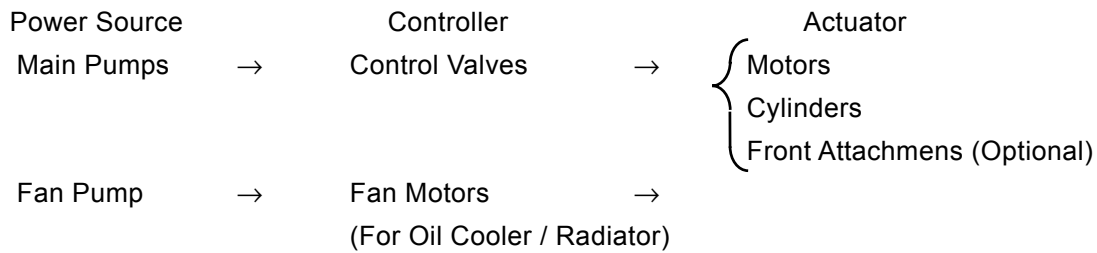

## SYSTEM / Hydraulic System

---

### PILOT CIRCUIT

#### Outline

- Pressure oil from the pilot pump is used to operate the operation control circuit, pump control circuit, valve control circuit, swing parking brake release circuit, travel motor swash angle control circuit, hydraulic oil heat circuit and emergency boom lower circuit.

# SYSTEM / Hydraulic System

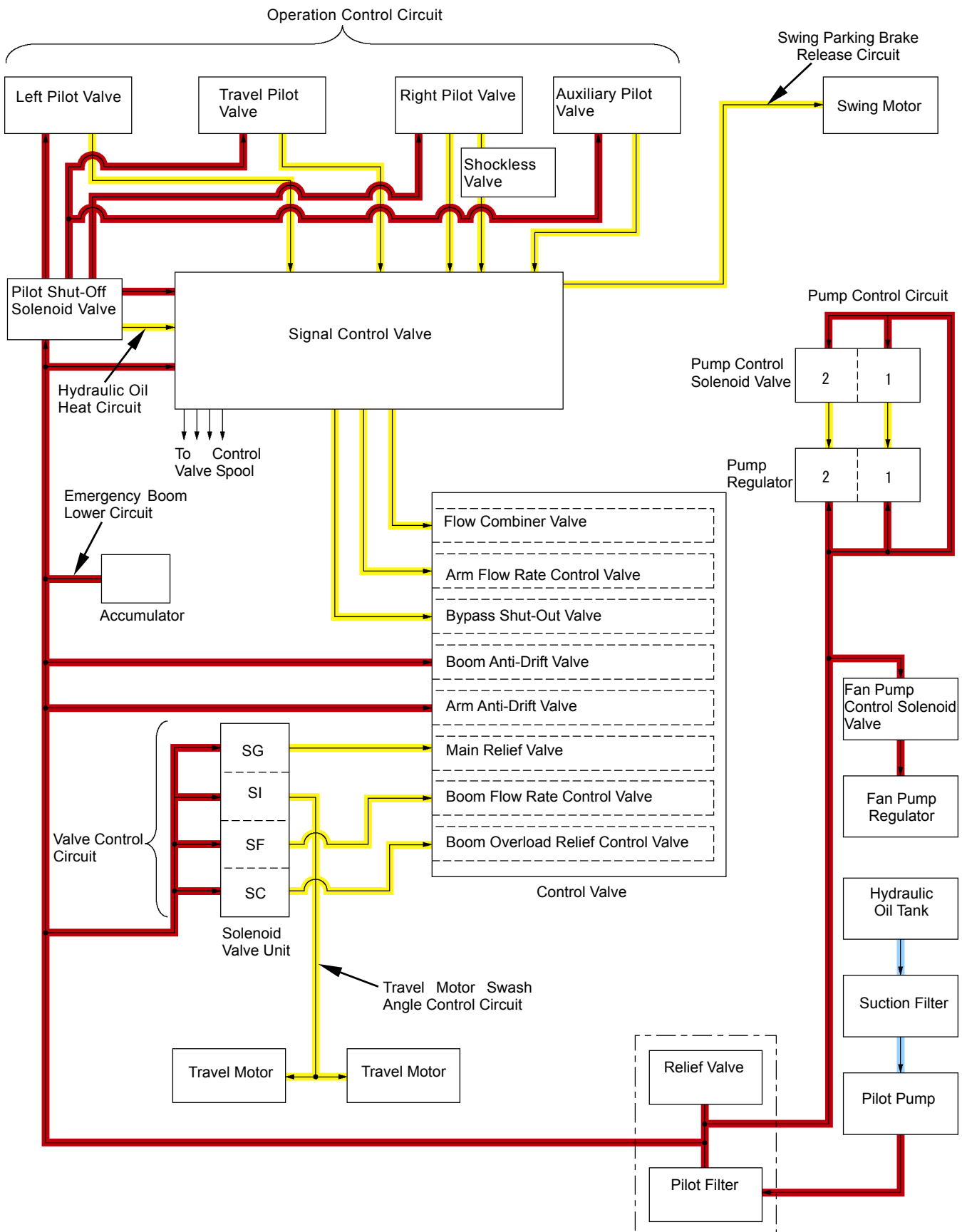

T1J1-02-04-001

## SYSTEM / Hydraulic System

---

### Operation Control Circuit

- The pilot valves control pressure oil from the pilot pump and operates the control valve spools.
- The signal control valve is provided between the pilot valves and the control valve. The shockless valve (in boom raise circuit) built in the signal control valve dampens quick spool movement in the control valve. (Refer to the COMPONENT OPERATION / Signal Control Valve group.)
- The shockless valve (in boom lower circuit) provided between the right pilot valve and the signal control valve dampens quick spool movement in the control valve.

# SYSTEM / Hydraulic System

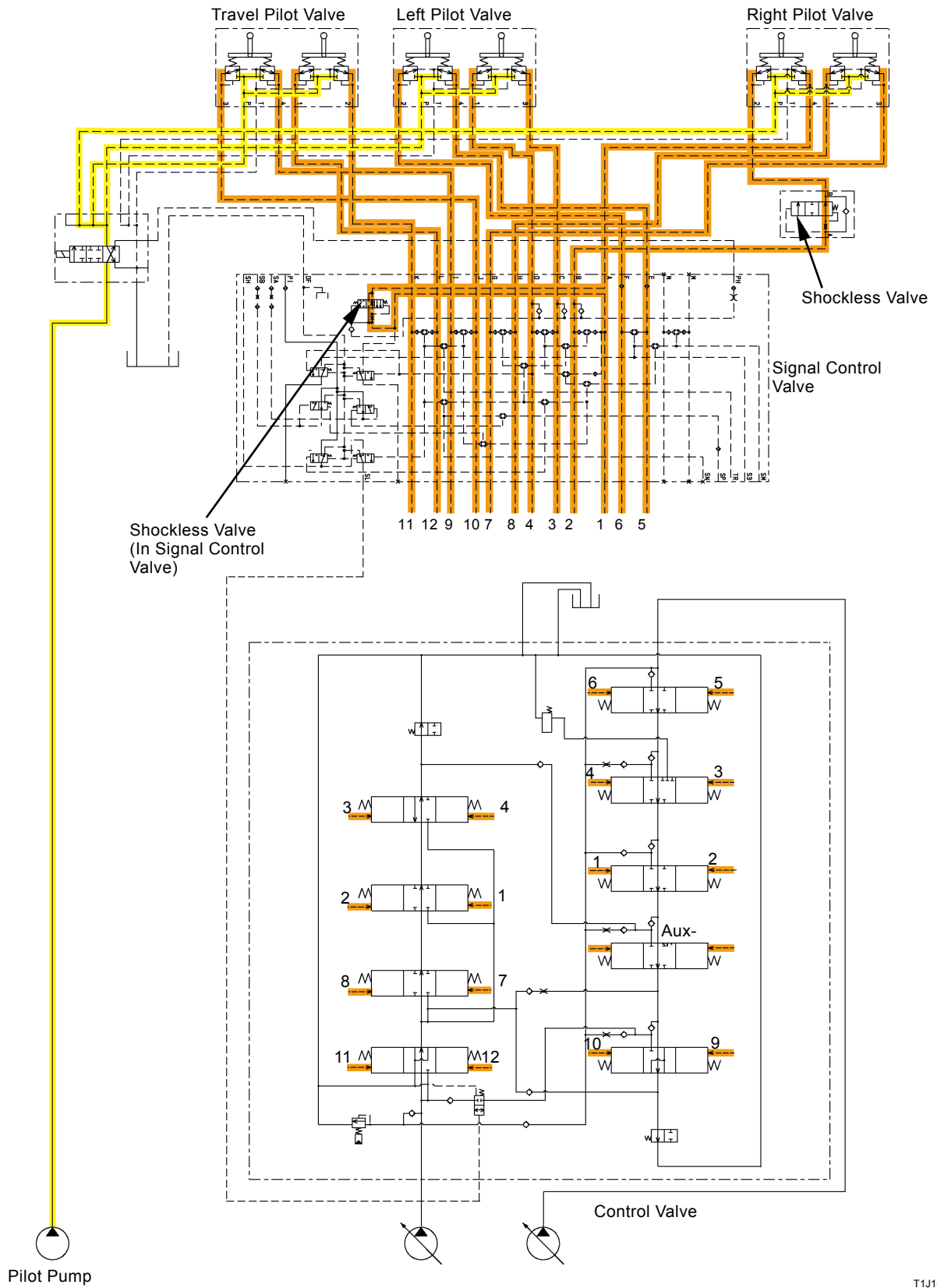

T1J1-02-04-002

- |                  |                 |                           |                             |
|------------------|-----------------|---------------------------|-----------------------------|
| 1 - Boom Raise   | 4 - Arm Roll-In | 7 - Bucket Roll-In        | 10 - Travel (Left Reverse)  |
| 2 - Boom Lower   | 5 - Left Swing  | 8 - Bucket Roll-Out       | 11 - Travel (Right Forward) |
| 3 - Arm Roll-Out | 6 - Right Swing | 9 - Travel (Left Forward) | 12 - Travel (Right Reverse) |



## SYSTEM / Hydraulic System

---

### Pump Control Circuit

- Main Pump Delivery Flow Rate Control
  - Pressure oil from the pilot pump flows to the pump control solenoid valve in regulator.
  - The pilot sensor in the controlled circuit sends the signal to MC.
  - The signal from pump regulator pressure sensor is always sent to MC.
  - MC sends the signals according to each signal to the pump control solenoid valve and controls the pump control solenoid valve.  
Therefore, the pump flow rate is controlled. (Refer to the Control System group / SYSTEM.)
- Fan Pump Delivery Flow Rate Control
  - Pressure oil from the pilot pump flows to the fan pump control solenoid valve in fan pump regulator.
  - MC activates the fan pump control solenoid valve and controls delivery flow rate of fan pump in order to adjust temperatures in oil cooler, radiator and intercooler properly.  
(Refer to Fan Pump Flow Rate Control in the Control System group / SYSTEM.)

# SYSTEM / Hydraulic System

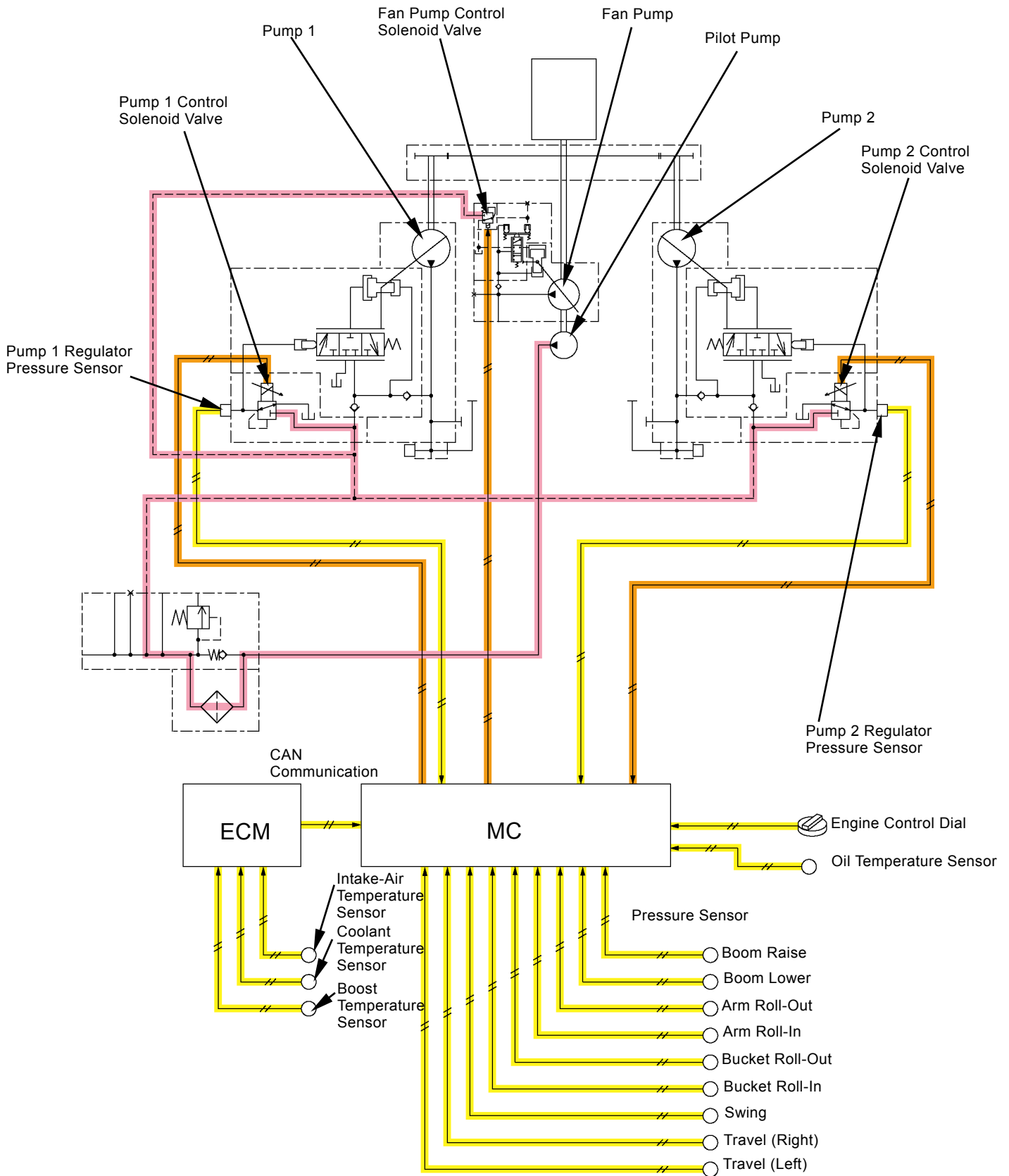

T1JB-02-04-007

## SYSTEM / Hydraulic System

---

### Valve Control Circuit (Refer to the Control Valve group / COMPONENT OPERATION.)

- The following valves are shifted by primary pilot pressure from the pilot pump, secondary pilot pressure from the pilot valve, solenoid valve units (SG, SF, SC), flow combiner valve spool in signal control valve and arm flow rate control valve control spool.
  - Pilot pressure from pilot pump: Boom anti-drift valve and arm anti-drift valve
  - Attachment pilot pressure (optional): Bypass shut-out valve (4-spool section)
  - Solenoid Valve Unit SG: Main relief valve
  - Solenoid valve unit SF: Boom flow rate control valve (switch valve)
  - Solenoid valve unit SC: Boom overload relief control valve
  - Flow combiner valve spool: Flow combiner valve
  - Arm flow rate control valve spool: Arm flow rate control valve (switch valve)

# SYSTEM / Hydraulic System

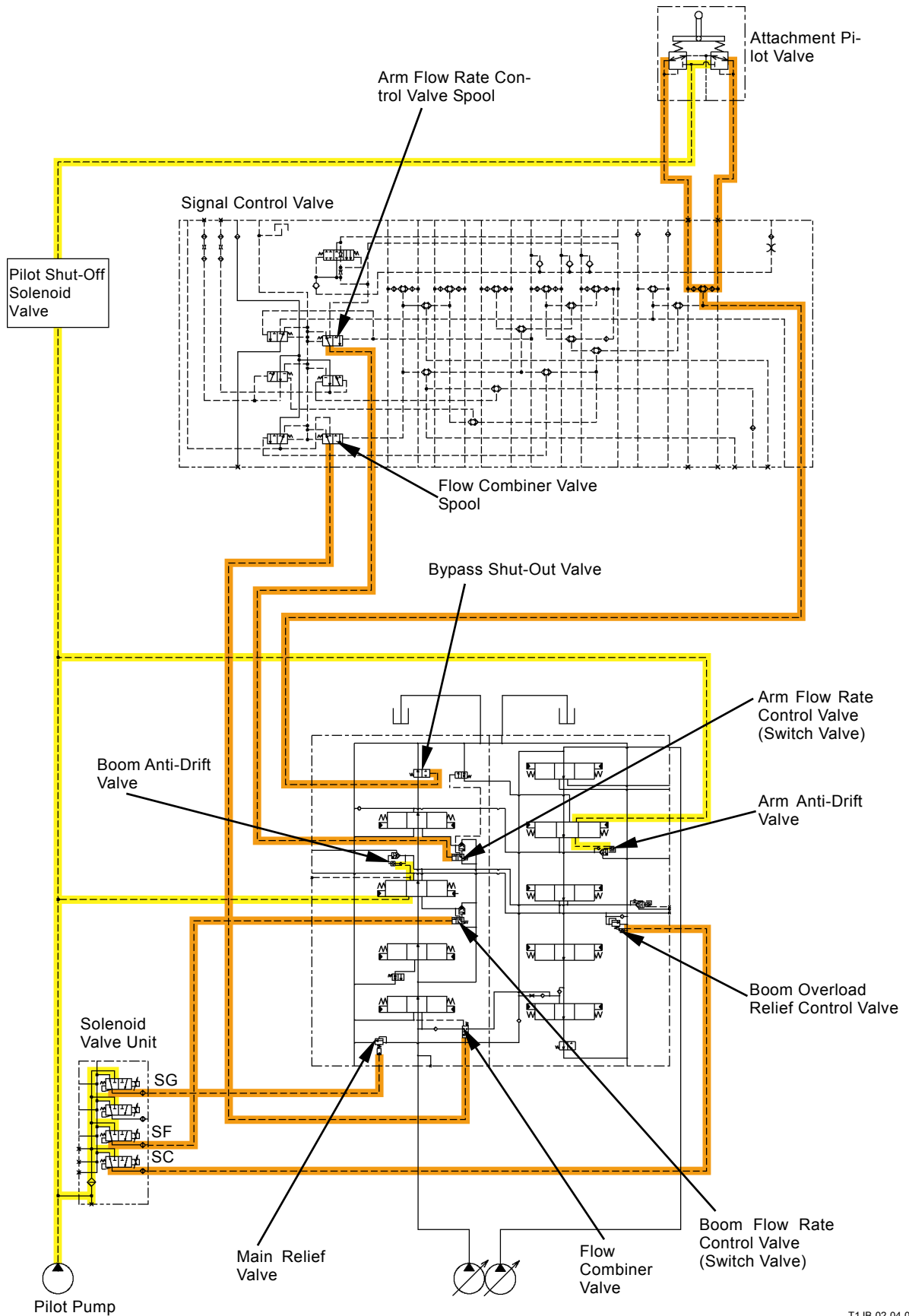

T1JB-02-04-001

## **SYSTEM / Hydraulic System**

---

### **Swing Parking Brake Release Circuit (Refer to the Swing Device group / COMPONENT OPERATION.)**

- When the front attachment and/or swing function is operated, pilot pressure selected by the shuttle valves in signal control valve shifts the swing parking brake release spool.
- Consequently, release signal pressure is routed to the swing motor and releases the swing parking brake.

### **Travel Motor Swash Angle Control Circuit (Refer to the Travel Device group / COMPONENT OPERATION.)**

- Pilot pressure from solenoid valve unit (SI) regulates the travel motor swash angle control valve. (Refer to the Valve Control in Control System group / SYSTEM.)

### **Hydraulic Oil Heat Circuit (Refer to the Others (Upperstructure) group / COMPONENT OPERATION.)**

- When the pilot shut-off solenoid valve is closed, pilot pressure oil is routed to the signal control valve so that hydraulic oil is warmed while passing through the orifice in signal control valve.
- This warmed hydraulic oil flows to the signal control valve and pilot valves so that the pilot system components are warmed.

# SYSTEM / Hydraulic System

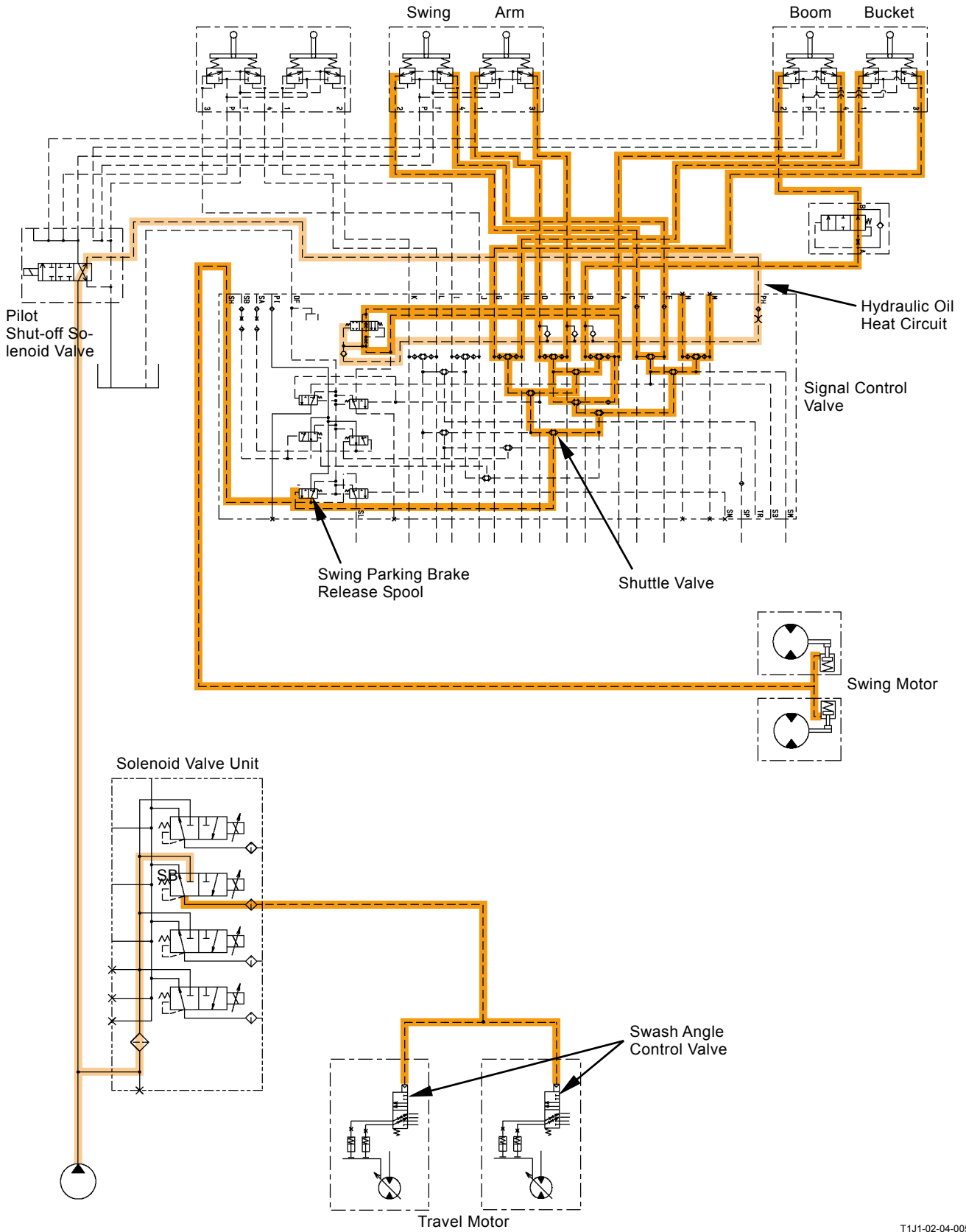

T1J1-02-04-005

## SYSTEM / Hydraulic System

---

### Emergency Boom Lower Circuit (Refer to the Others (Upperstructure) / COMPONENT OPERATION.)

- The accumulator is provided between pilot pump and pilot shut-off solenoid valve for boom lower at emergency. The accumulator accumulates pressure oil from the pilot pump.
- When the engine stops suddenly and the control lever is operated with the pilot shut-off lever in UNLOCK position, pressure oil from the accumulator flows to each spool in the control valve through each pilot valve.
- Therefore, as the spool in operated control valve is operated, the circuit between main pump and actuator is connected through the control valve spool.
- As pressure oil between control valve and actuator flows to the hydraulic oil tank through the control valve spool, pressure between control valve and actuator decreases.
- Consequently, when the engine stops suddenly, by operating the control lever (boom lower) right away, the front attachment can be lowered onto the ground (due to own weight).

 *NOTE: Immediately after the engine stops, by operating all the control levers, any pressure in the circuit between control valve and actuator can be released.*

 *NOTE: Immediately after the engine stops (the key switch is turned OFF), the battery relay is kept ON for a specified time due to load damp relay operation. (Refer to the Surge Voltage Prevention Circuit in Electrical System group / SYSTEM.) Therefore, electrical current from the battery (fuse #4) flow to the pilot shut-off solenoid valve and the pilot shut-off solenoid valve is kept ON.*

# SYSTEM / Hydraulic System

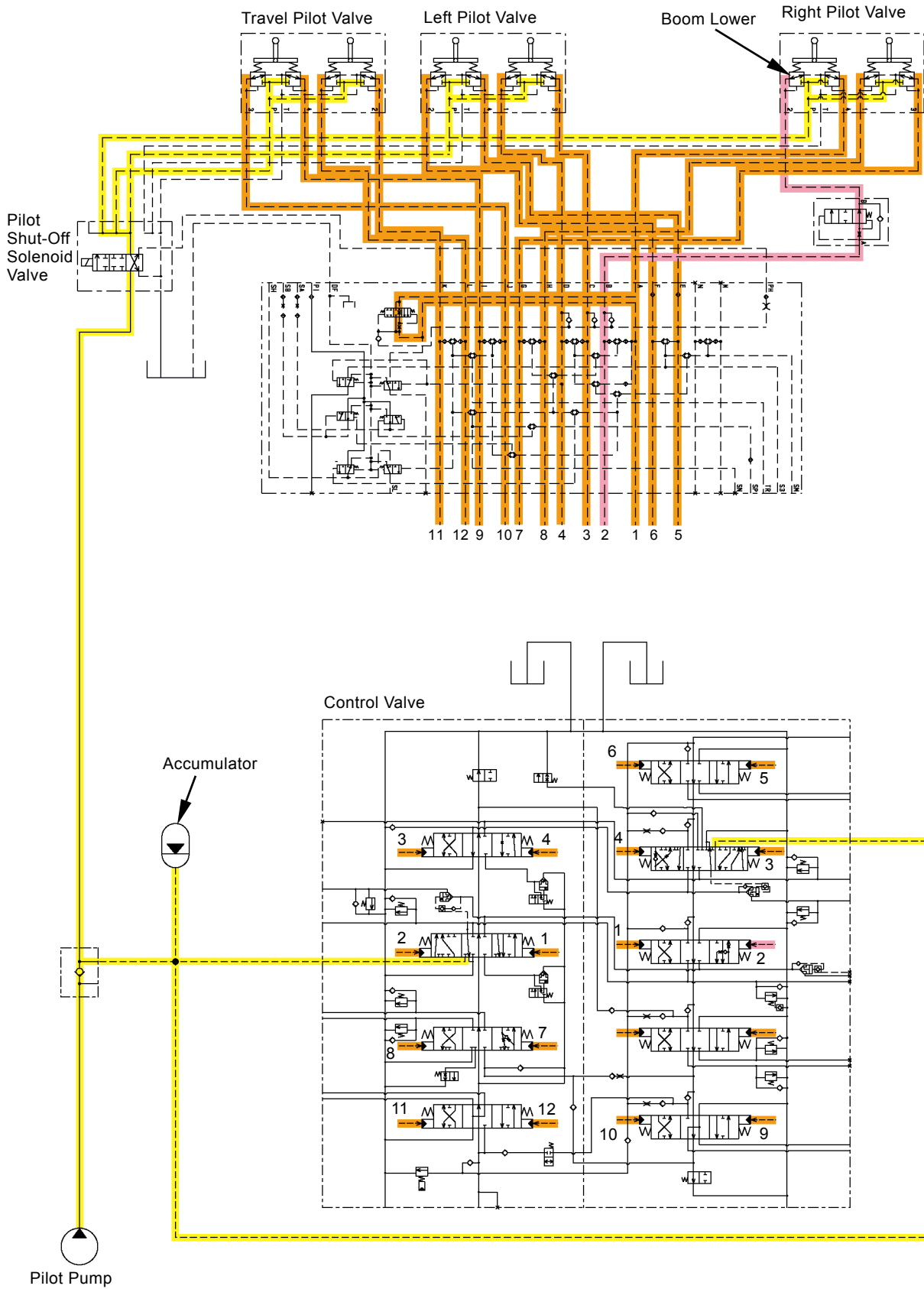

T1JB-02-04-002



## SYSTEM / Hydraulic System

---

### MAIN CIRCUIT

#### Outline

- Main pumps (1, 2) and fan pump draw hydraulic oil from the hydraulic oil tank. Main pump 1 and main pump 2 deliver pressure oil to the 4-spool control valve and the 5-spool control valve respectively.
- The fan pump delivers hydraulic oil to the fan motor and drives the fan motor.
- Delivered pressure oil from the main pump is routed to the motor or cylinder in response to operation of the spool in the control valve.
- Return oil from the motor and/or cylinder flows back to the hydraulic oil tank via the control valve, low-pressure relief valve and oil cooler.
- The low-pressure relief valve is provided in the return circuit (between control valve and oil cooler) of main circuit, and keeps a constant pressure in the main circuit.
- Therefore, actuator operation is improved when cavitation occurs.
- When oil temperature is low (high viscosity), oil flow resistance increases in the oil cooler, which opens the bypass check valve, so that hydraulic oil returns directly to the hydraulic oil tank.

# SYSTEM / Hydraulic System

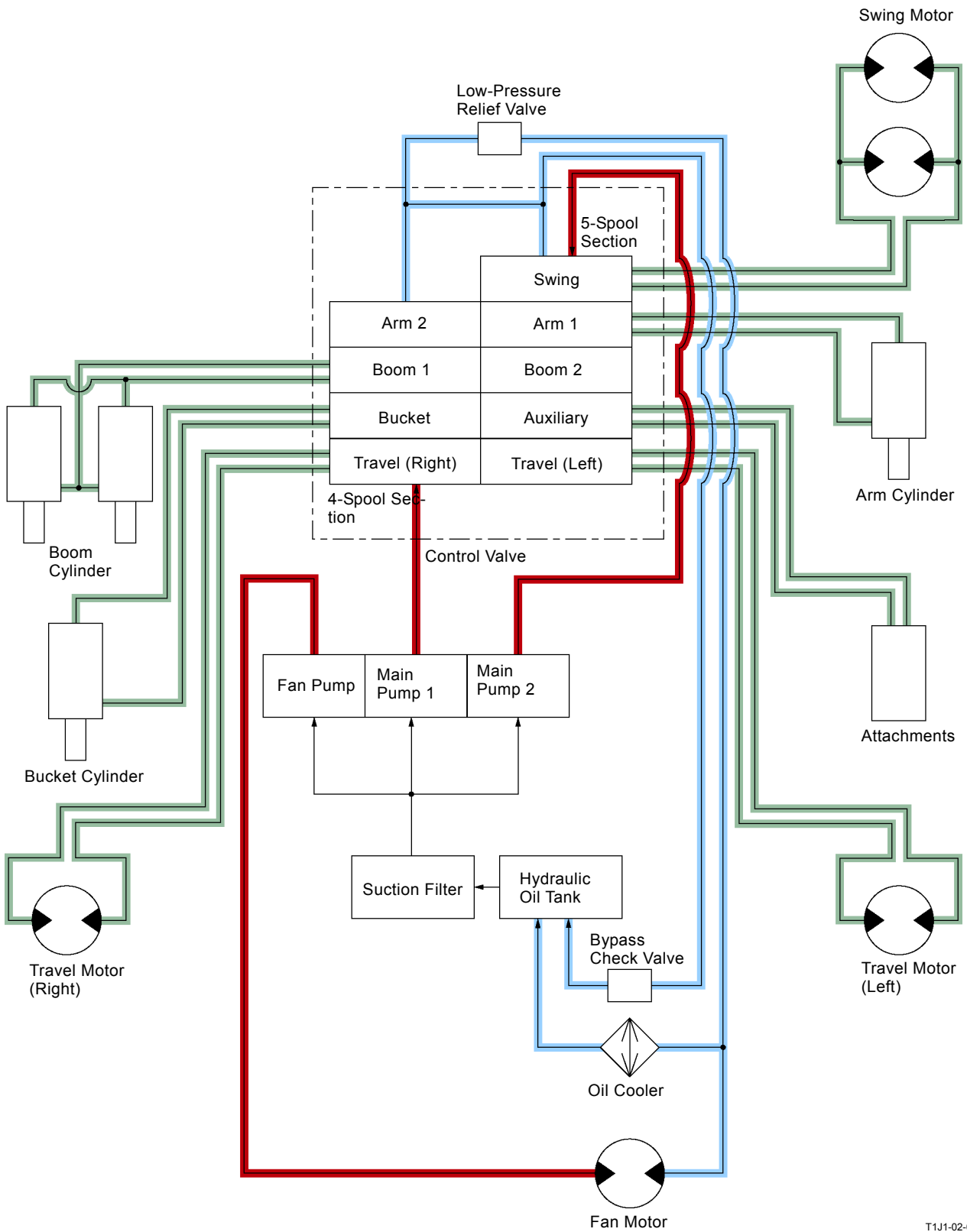

T1J1-02-04-008

## SYSTEM / Hydraulic System

---

### Neutral Circuit

- When the control lever is in neutral, pressure oil from the main pump passes through the control valve and returns to the hydraulic oil tank.

### Single Operation Circuit

- Pressure oil from main pump 1 is routed to the 4-spool control valve and is further routed to each spool of the travel (right), bucket, boom 1 and arm 2.
- Pressure oil from main pump 2 is routed to the 5-spool control valve and is further routed to each spool of the swing, arm 1, boom 2, auxiliary and travel (left).
- The boom and arm are actuated by pressure oil from two main pumps. Pressure oil from each main pump is combined and supplied together.

# SYSTEM / Hydraulic System

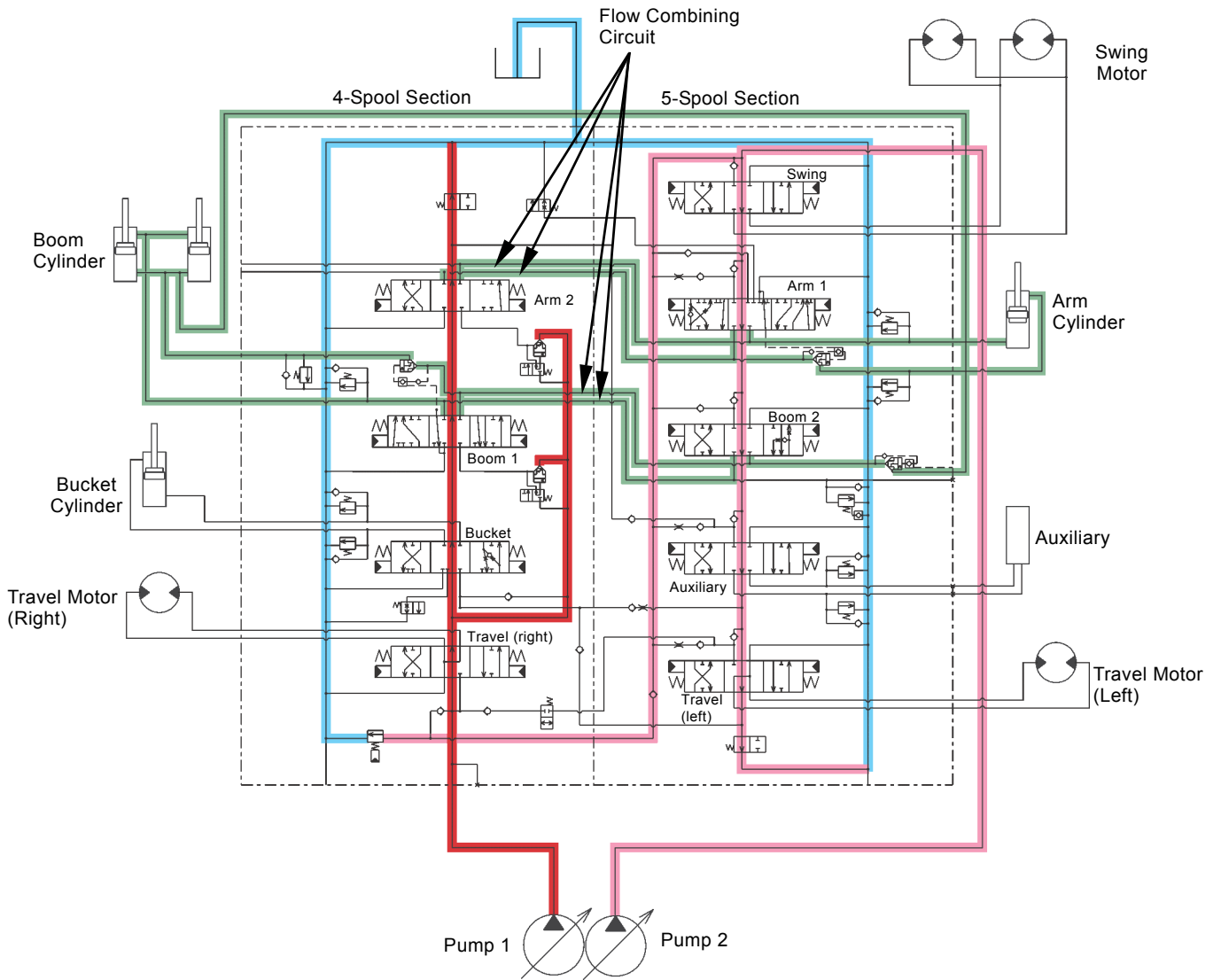

T1JB-03-03-013

## SYSTEM / Hydraulic System

---

### Combined Operation Circuit

- Swing and Boom Raise Operation
  1. When the boom is raised while swinging, pilot pressure shifts the swing, boom 1 and boom 2 spools.
  2. Pressure oil from pump 1 flows into the boom cylinders through the parallel circuit and the boom 1 spool, and raises the boom.
  3. Pressure oil from pump 2 flows into the swing motor through the swing spool.
  4. At the same time, pressure oil from pump 2 flows through the parallel circuit and flows into the boom cylinders is combined with pressure oil from pump 1, and raises the boom.

# SYSTEM / Hydraulic System

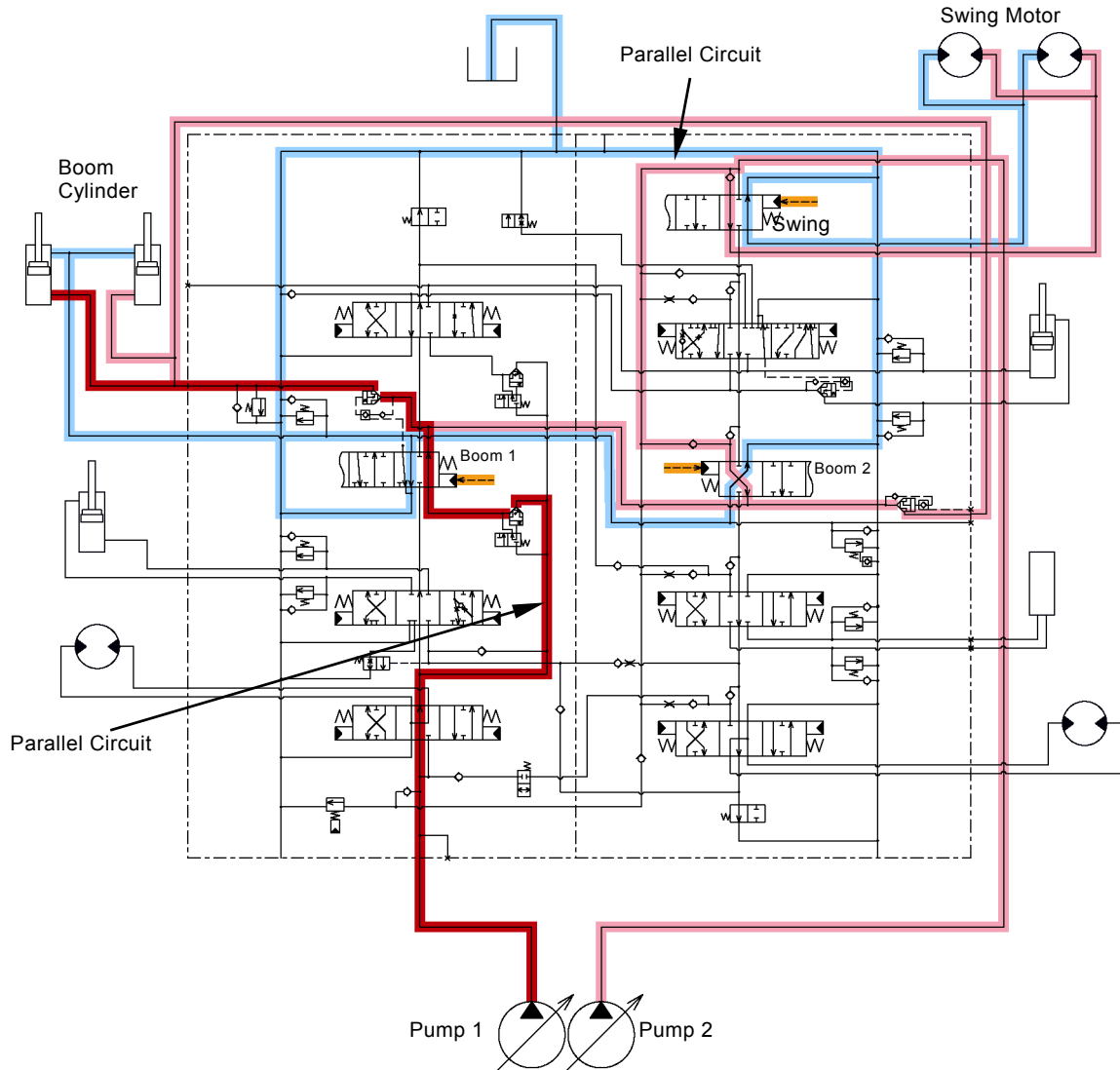

T1JB-02-04-004

## SYSTEM / Hydraulic System

---

- Travel and Arm Roll-In Operation
  1. When the arm is rolled in while traveling, pilot pressure shifts the travel, arm 1 and 2 spools.
  2. At the same time, right travel pilot pressure shifts the flow combiner valve control spool in the signal control valve. Pressure oil from the flow combiner valve control spool is routed to the flow combiner valve and shifts the flow combiner valve.
  3. Pressure oil from pump 1 drives the right travel motor through the right travel spool.
  4. At the same time, pressure oil from pump 1 passes through the flow combiner valve and the left travel spool and drives the left travel motor.
  5. Pressure oil from pump 2 flows into the arm cylinder through the arm 1 spool and moves the arm.
  6. Consequently, pressure oil from pump 2 is used only to operate the arm. Pressure oil from pump 1 is equally routed to both the right and left travel motors and ensures that the machine can travel straight.

# SYSTEM / Hydraulic System

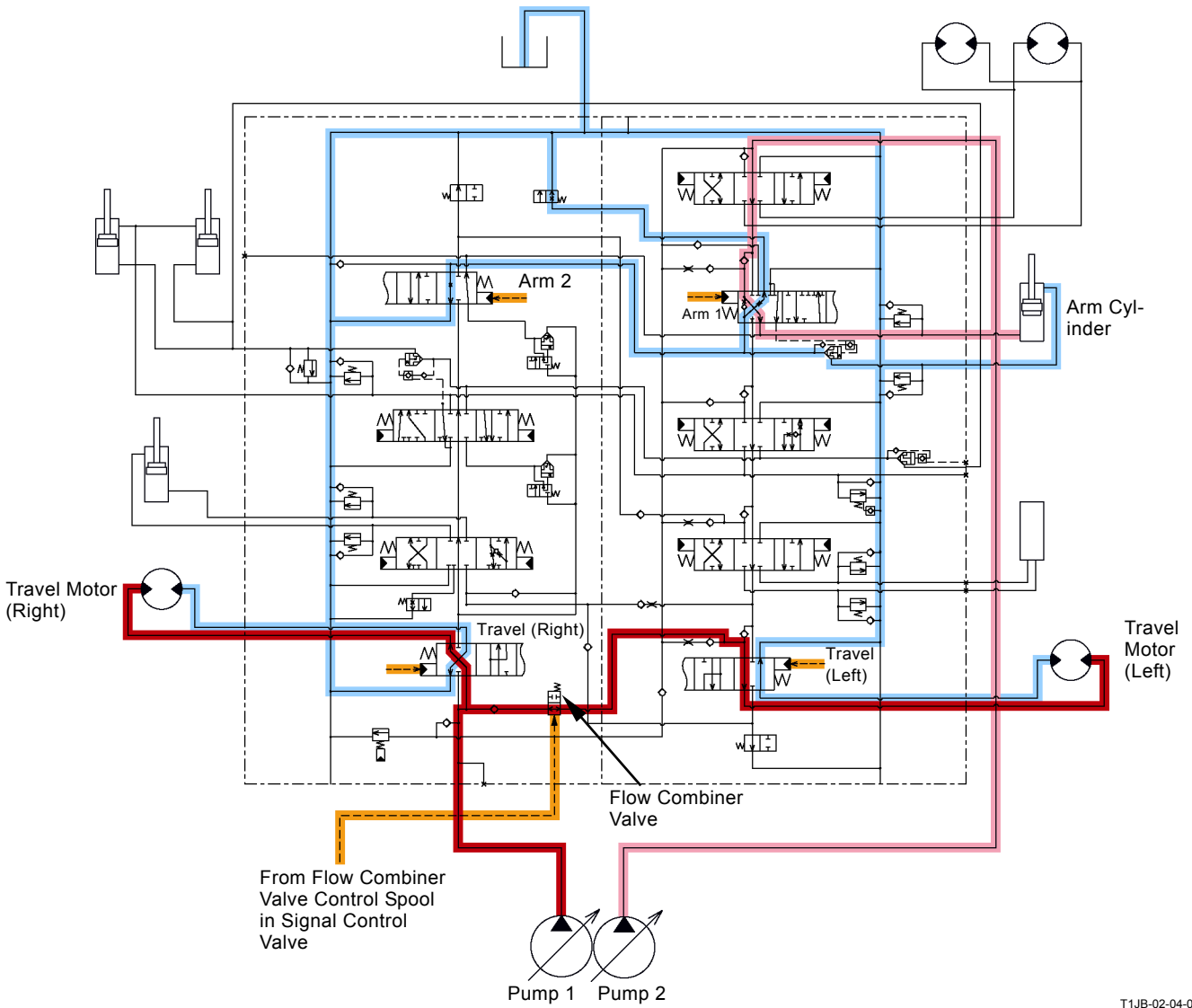

T1JB-02-04-005



## SYSTEM / Hydraulic System

- Boom Raise / Arm Roll-In (Arm Regenerative Circuit)

1. Pressure oil from pump 1 is routed to the boom 1 spool and arm 2 spool through the 4-spool parallel circuit.
2. Pressure oil from pump 2 is routed to the boom 2 spool through the arm 1 spool and 5-spool parallel circuit.
3. During combined operation of boom raise and arm roll-in, arm roll-in pilot pressure shifts the arm flow rate control valve control spool in signal control valve.
4. Boom raise pilot pressure flows to the arm flow rate control valve control spool and acts on the switch valve in arm flow rate control valve.
5. When the switch valve is shifted, the poppet valve in arm flow rate control valve moves to the direction to restrict the passage in arm 2 in response to the boom raise control pressure.
6. Consequently, more pressure oil from pump 1 flows to the boom 1 side and boom operating speed is kept.
7. As return oil from the arm cylinder rod side is routed to the arm cylinder bottom side due to the regenerative circuit in arm 1 spool, arm roll-in speed increases.

**Operation in Arm Regenerative Circuit:**

1. When arm is rolled in with the arm rolled-out position, arm speed becomes faster comparing with pressure oil amount from pump 2 due to arm own weight.
2. Therefore, pressure between pump 2 and arm cylinder bottom decreases.
3. When pressure in the cylinder bottom side is lower than that in rod side, the check valve is opened.
4. Therefore, return oil from the cylinder rod side is routed to the bottom side, is combined with oil from pump 2, and combined oil is routed to the cylinder bottom side.
5. Consequently, the regenerative operation is operated and cylinder speed increases.

 **NOTE:** Refer to the Flow Rate Control Valve in Control Valve group / COMPONENT OPERATION.

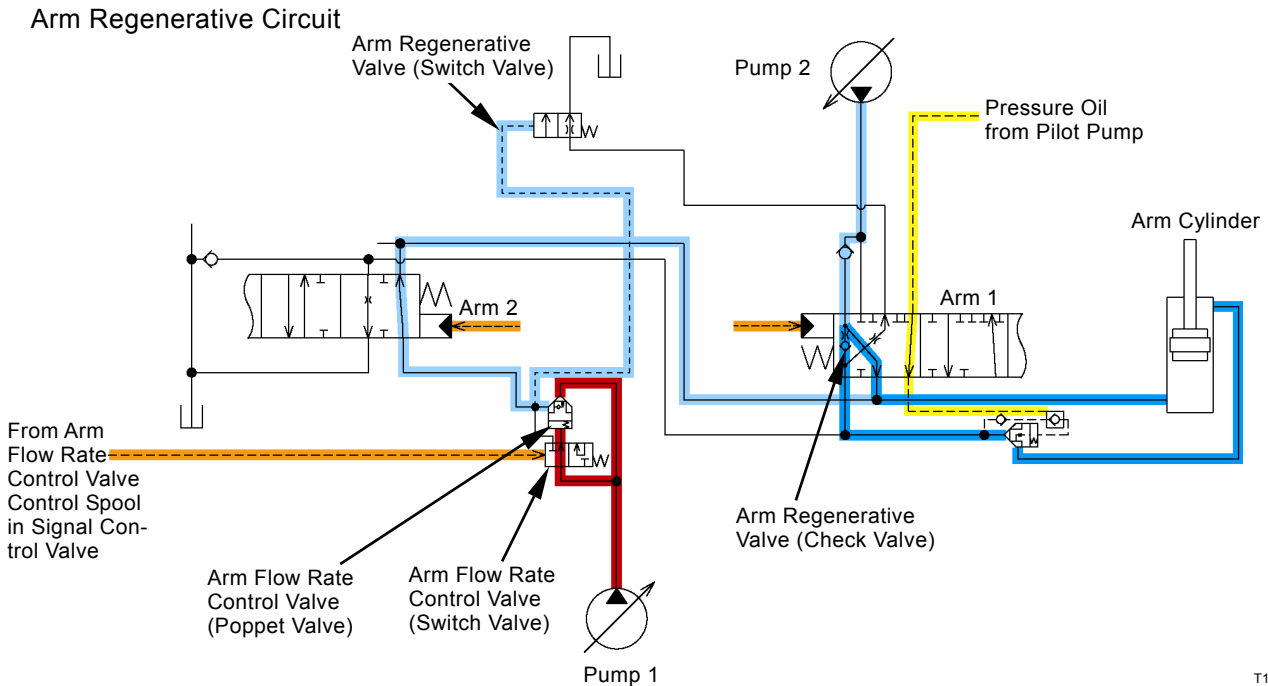

T1J1-02-04-012

# SYSTEM / Hydraulic System

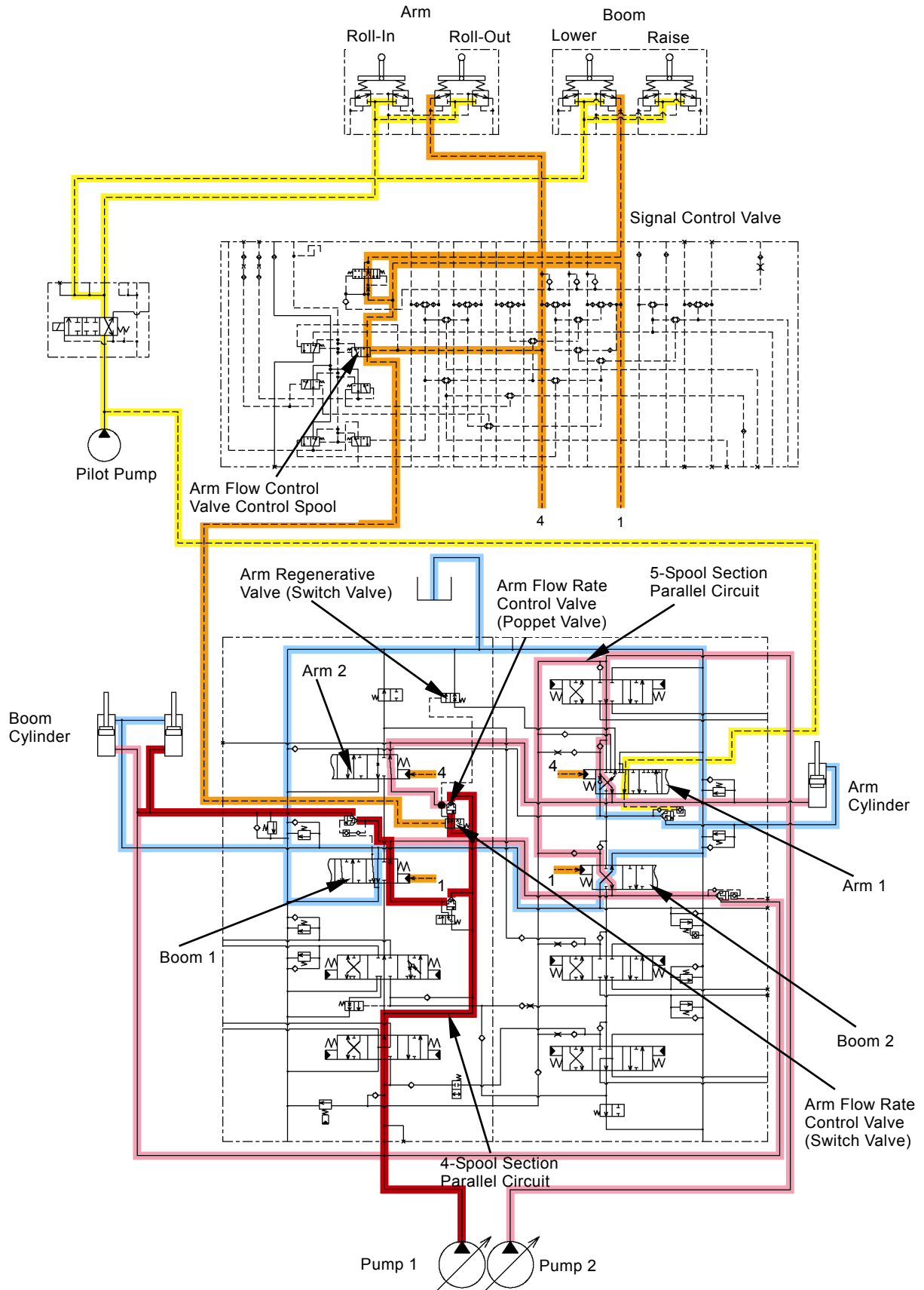

T1JB-02-04-006

## SYSTEM / Hydraulic System

### COUNTERWEIGHT REMOVAL / INSTALLATION CIRCUIT (OPTIONAK)

1. When the counterweight hoist/lower control lever (optional) is operated, pressure oil from the pilot pump flows through the counterweight pilot valve and shifts the auxiliary spool in the 5-spool control valve to remove/install the counterweight.
2. Pressure oil from main pump 2 flows into the counterweight removal / installation cylinder through the auxiliary spool from the neutral circuit in 5-spool control valve.
3. When hoisting the counterweight, pressure oil flows into the cylinder bottom through the check valves in holding valve and slow return valve.
4. When lowering the counterweight, pressure oil is divided into two directions. One flows to the cylinder rod side. Another flows to the holding valve.
5. The holding valve is opened by pressure in the rod side and flows return oil from the bottom side.
6. Return oil flow from the cylinder bottom is regulated by the slow return valve.
7. Return oil flows to the hydraulic oil tank through the holding valve.

 **NOTE:** During counterweight removal and installation operation, flow rates of pumps 1, 2 are minimum. (Refer to the Pump Control during Counterweight Removal and Installation in Control System group / SYSTEM.)

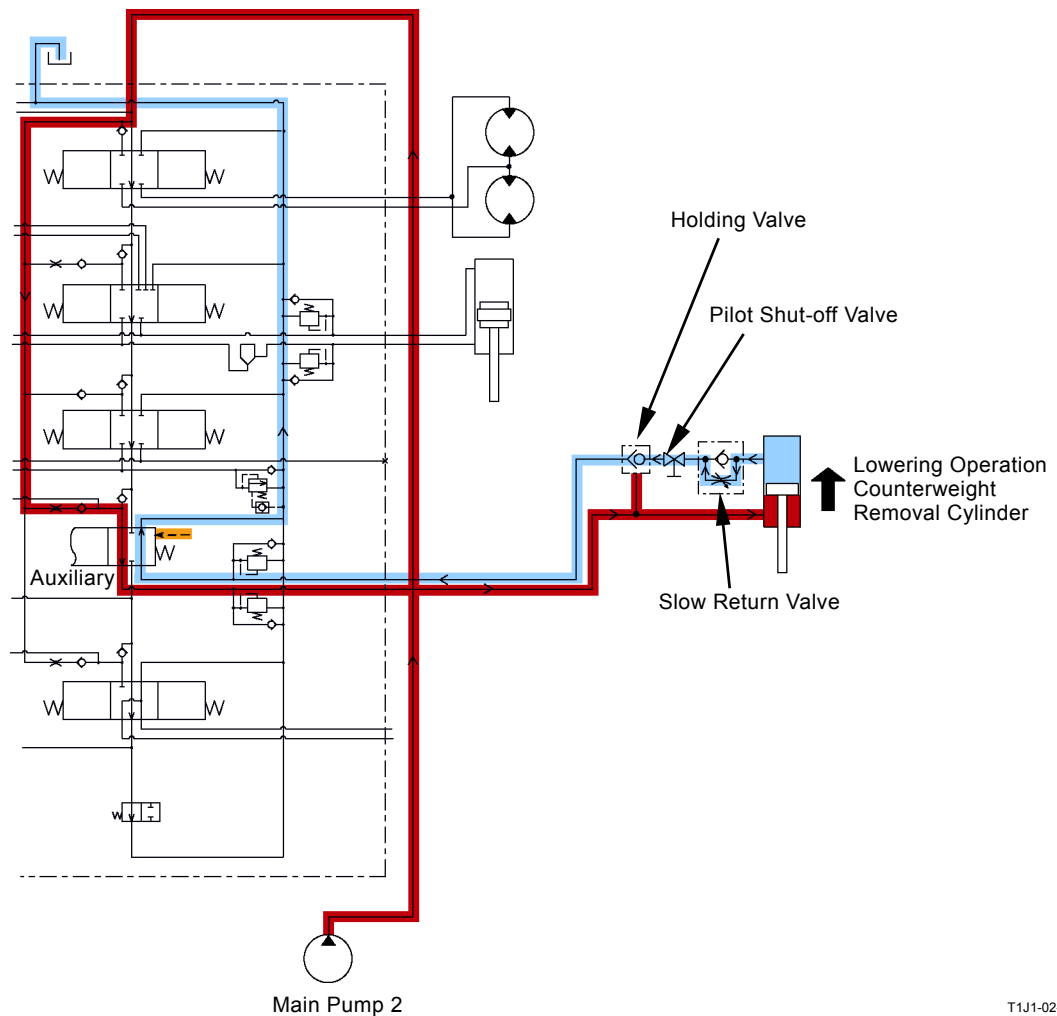

T1J1-02-04-011

## SYSTEM / Electrical System

---

### OUTLINE

The electrical circuit is broadly divided into the main circuit, monitor circuit and control circuit.

- Main Circuit  
The engine and accessory operation related circuit.
- Monitor Circuit  
The electrical circuit group consists of the monitors, sensors and switches, and displays the machine operation status.
- Control Circuit (Refer to Control System / SYSTEM.)  
The control circuit is categorized into the engine, pump and valve control circuits. Each circuit consists of the actuators such as solenoid valves, MC (main controller), ECM (engine control module), switch boxes, sensors and pressure switches.

## SYSTEM / Electrical System

---

### MAIN CIRCUIT

The major functions and circuits in the main circuit are as follows.

- Electric Power Circuit: Supplies all electric power to all electrical systems on this machine. [Key Switch, Batteries, Fuses (Fuse Boxes, Fusible Links), Battery Relay]
- Accessory Circuit  
Becomes operative when the key switch is turned to the ACC position.
- Starting Circuit  
Starts the engine. [Key Switch, Starter, Starter Relay 2]
- Charging Circuit  
Charges the batteries. [Alternator, (Regulator)]
- Surge Voltage Prevention Circuit  
Prevents the occurrence of surge voltage developed when stopping the engine. [Load Damp Relay]
- Pilot Shut-Off Circuit (Key Switch: ON)  
Supplies pressure oil to the pilot valve from the pilot pump by the pilot shut-off solenoid valve.
- Security Lock Circuit  
Cut electrical current for starting from the key switch according to the signals from external alarm system or monitor unit. Turns the pilot shut-off solenoid valve OFF and blocks the pilot circuit.
- Engine Stop Circuit (Key Switch: OFF)  
Stops the engine by using ECM. (MC, ECM)
- Security Horn Circuit  
Operate the security horn according to the signals from external alarm system or monitor unit.
- Working Light Circuit  
Turn on the work light and cab light.
- Wiper Circuit  
Operate the intermittent operation of wiper and the washer.

## SYSTEM / Electrical System

---

(Blank)

## SYSTEM / Electrical System

---

### ELECTRIC POWER CIRCUIT (KEY SWITCH: OFF)

The battery ground terminal is connected to the vehicle frame. Current from the battery plus terminal flows as shown below when the key switch is turned OFF.

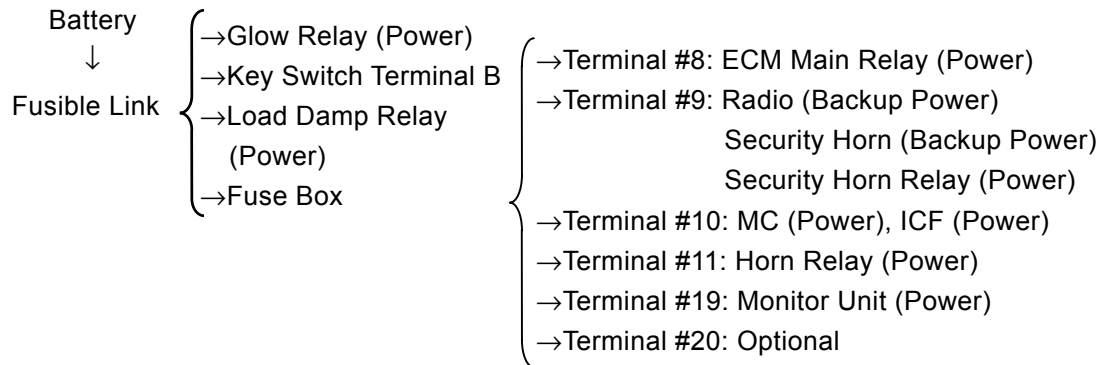





## SYSTEM / Electrical System

---

### ACCESSORY CIRCUIT

1. When the key switch is turned to the ACC position, terminal B is connected to terminal ACC in the key switch.
2. Current from key switch terminal ACC flows to radio (#12), cab light (#12), lighter (#13) and auxiliary (#15) through the fuse box and makes each accessory operable.

# SYSTEM / Electrical System

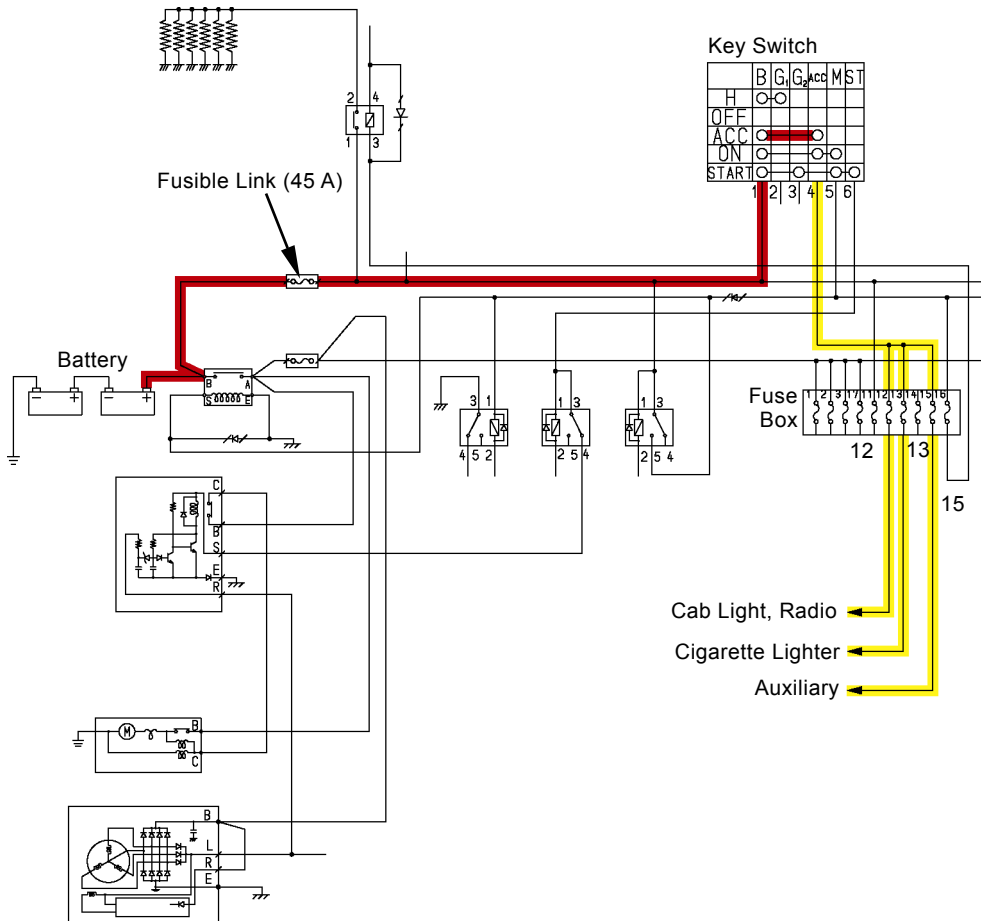

T1J1-02-05-002

## SYSTEM / Electrical System

---

### STARTING CIRCUIT (KEY SWITCH: START)

1. When the key switch is turned to the START position, terminal B is connected to terminals M and ST in the key switch.
2. As current from terminal M excites the battery relay, battery current is routed to starter terminal B and starter relay 2 terminal B through the battery relay.
3. Current from terminal ST flows to starter relay 2 terminal S through the starter cut relay.
4. Current flows to the starter relay 2 coil and starter relay 2 is turned ON.
5. Current flows to starter terminal C from starter relay 2 terminal C.
6. Consequently, the relay in starter is turned ON so that the starter begins rotating.
7. On the other hand, current from key switch terminal M flows to MC, ICF, the monitor unit and ECM through fuse #18 as a signal indicating that the key switch is in the ON or START position.
8. As soon as ECM receives this signal, ECM turns the ECM main relay ON.
9. Current from the battery flows to ECM through fuse #8, the ECM main relay and fuse #14 and the main power is turned ON.
10. ECM makes the engine starting condition.

# SYSTEM / Electrical System

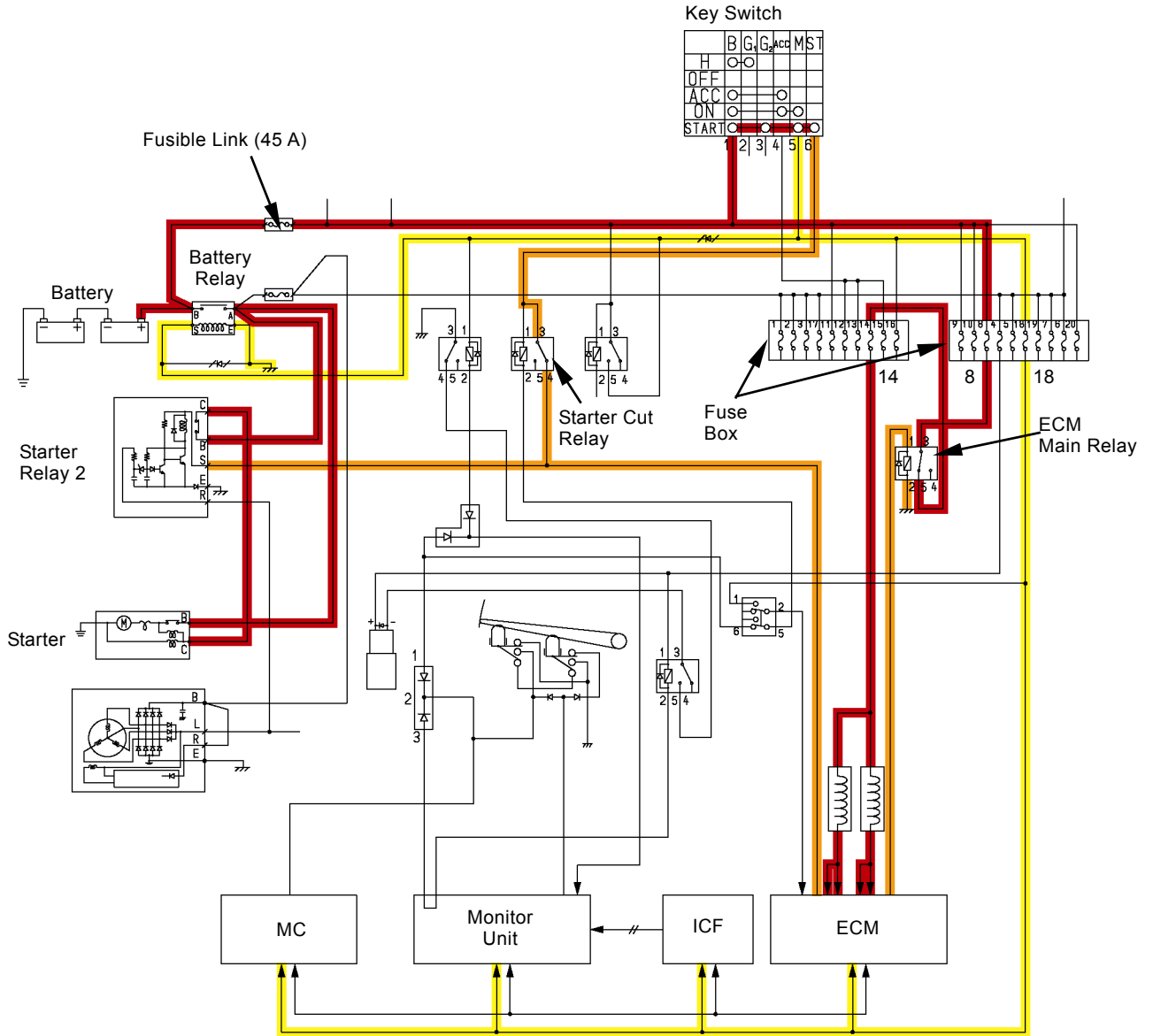

T1J1-02-05-003

## SYSTEM / Electrical System

### Starter Relay 2 Operation

1. When the key switch is turned to the START position, key switch terminal B is connected to terminal ST. Current is routed to the base in transistor (Q2) through resistance R4 in starter relay 2. Then, transistor (Q2) is turned ON and current flows to coil (L) in starter relay 2. Therefore, starter terminal B is connected to terminal C and the starter is operated.
2. After the engine starts, the alternator starts generating electricity and voltage at starter relay 2 terminal R increases.
3. When this voltage increases up to 21 to 22 V, Zener diode (Z) is turned ON. Consequently, transistor (Q1) is turned ON. Then, current to the base of transistor (Q2) does not flow and transistor (Q2) is turned OFF. At this moment, starter terminal B is disconnected from terminal C and the starter is turned OFF.

 **NOTE:** Condenser C1 is used to stabilize the operating voltage. Diode D4 protects the circuit in case the battery terminals are reversely connected.

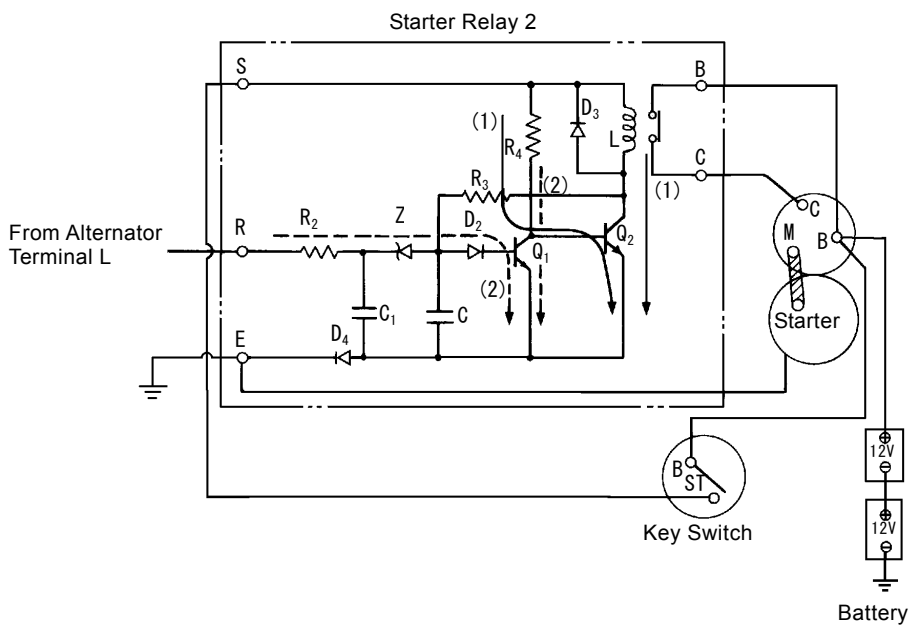

T107-04-04-003

## SYSTEM / Electrical System

---

(Blank)

## SYSTEM / Electrical System

### CHARGING CIRCUIT (KEY SWITCH: ON)

1. After the engine starts and the key switch is released, the key switch moves to the ON position.
2. Key switch terminal B is connected to terminals ACC and M in the key switch with the key switch ON.
3. The alternator starts generating electricity with the engine running. Current from alternator terminal B flows to the batteries through the battery relay and charges the batteries.
4. Current from alternator terminal L flows to the monitor unit, turns the alternator alarm OFF and flows to ICF.

 **NOTE:** Monitor unit detects the alternator charging according to power from the alternator and turns the Alternator Alarm OFF.

Monitor Unit

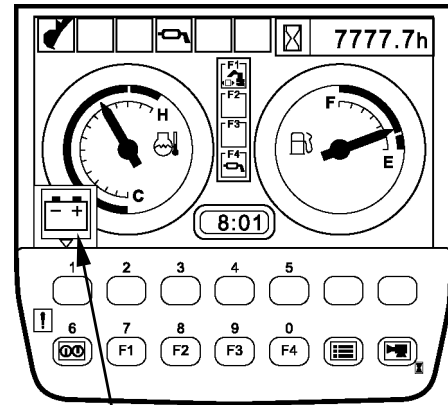

T1J1-05-01-007

Alternator  
Alarm

# SYSTEM / Electrical System

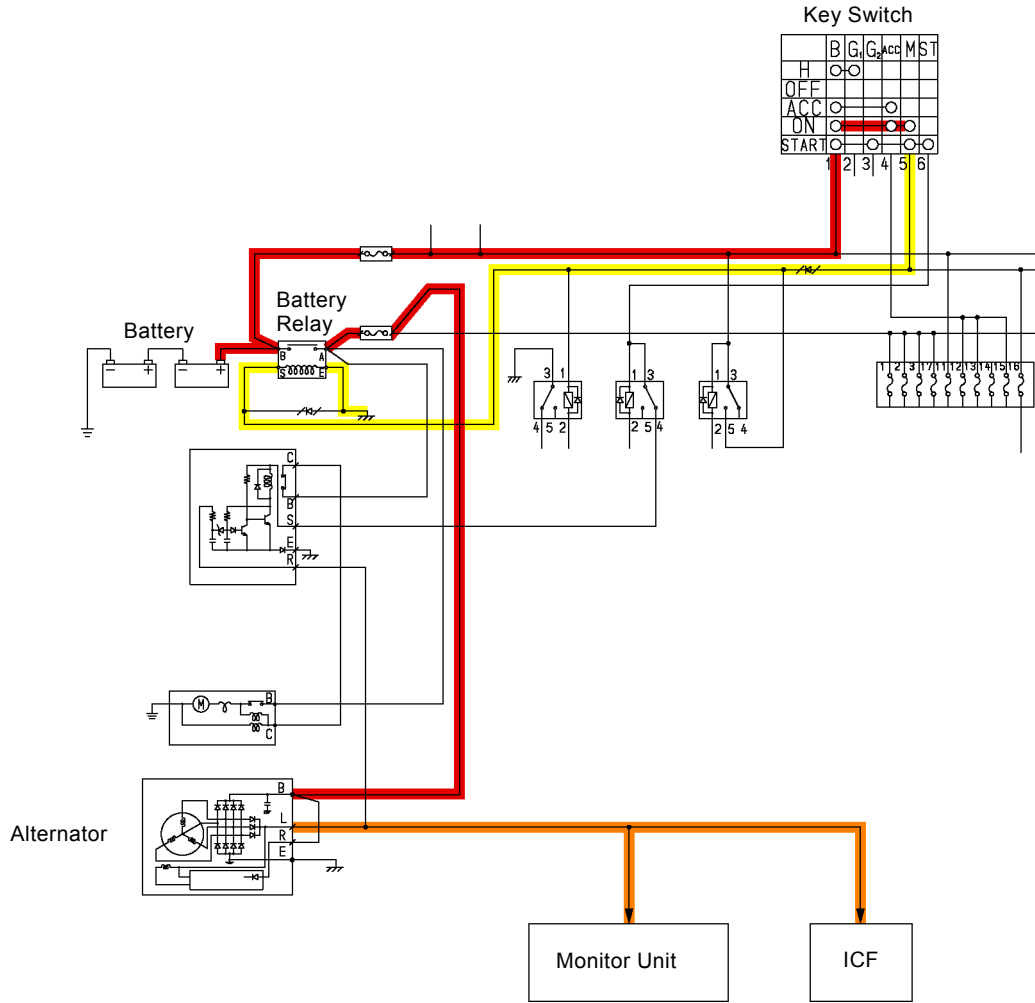

T1J1-02-05-004



## SYSTEM / Electrical System

### Alternator Operation

- The alternator consists of field coil FC, stator coil SC and diode D. The regulator consists of transistors (T1 and T2), Zener diode ZD and resistances (R1 and R2).
- At the beginning, no current is flowing through field coil FC. When the rotor starts rotating, alternate current is generated in stator coil SC by the rotor remanent magnetism.
- When current flows through field coil FC, the rotor is further magnetized so that the generating voltage increases. Thereby, current flowing through field coil FC increases. Therefore, generating voltage increases further and the batteries start charging.
- Alternator terminal B is connected to base B of transistor T1 through the circuit [B → R → RF → (R) → (R1)].
- When the battery relay is ON, the battery voltage is applied to base B of transistor T1 so that collector C is connected to emitter E. Therefore, field coil FC is grounded through transistor T1.

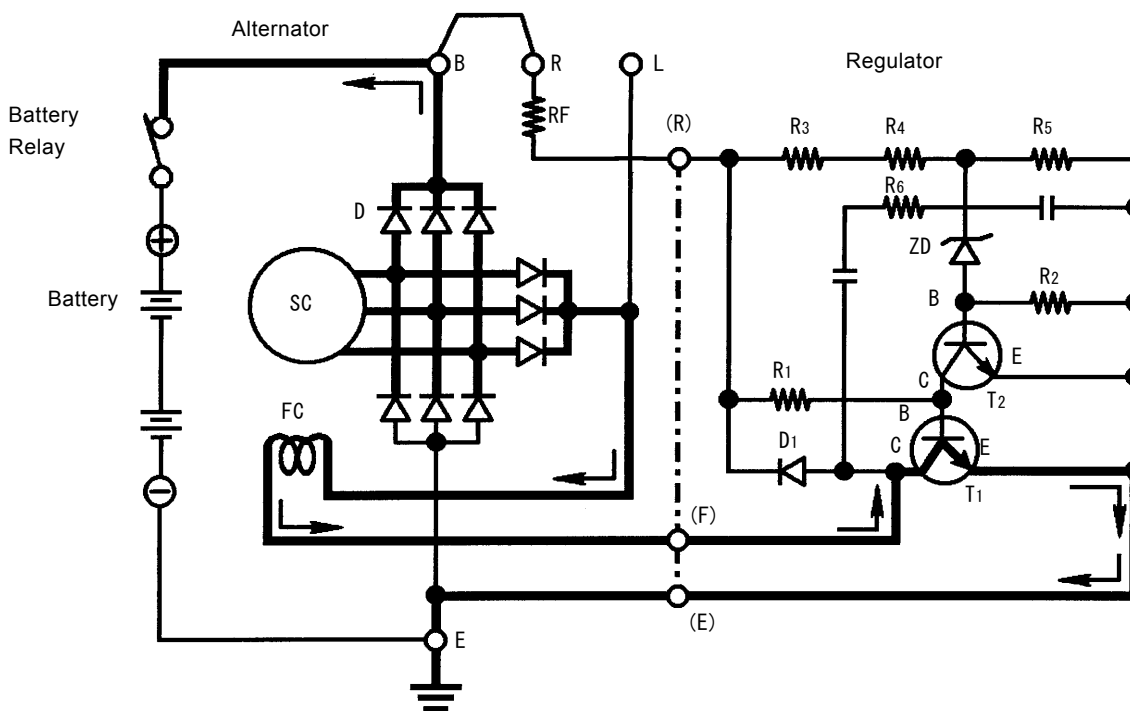

T157-04-02-008

## SYSTEM / Electrical System

### Regulator Operation

- When generating voltage increases more than the set-voltage of Zener diode ZD, current flows to base B of transistor T2 and collector C is connected to emitter E.
- Current which was routed to base B of transistor T1 disappears due to transistor T2 operation so that transistor T1 is turned OFF.
- No current flows through field coil FC and generating voltage at stator coil SC decreases.
- When generating voltage decreases lower than the set-voltage of Zener diode ZD, transistor T2 is turned OFF and transistor T1 is turned ON again.
- Current flows through field coil FC and generating voltage at stator coil SC increases. The above operation is repeated so that the alternator generating voltage is kept constant.

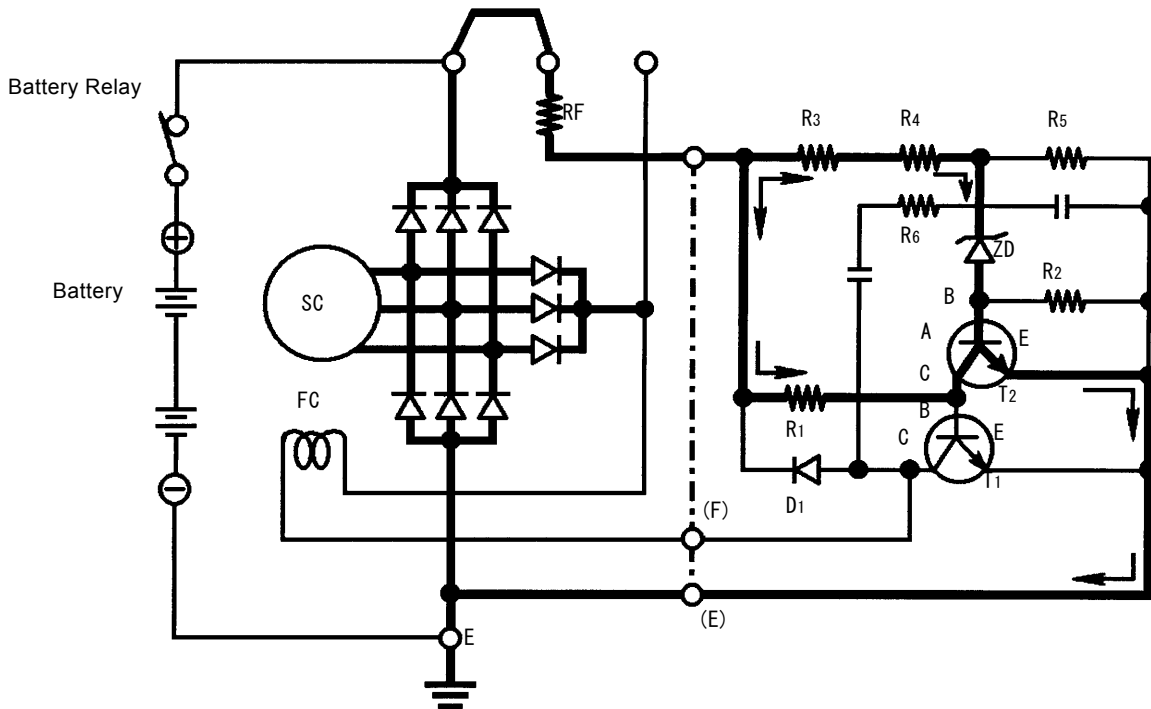

T157-04-02-009

## SYSTEM / Electrical System

---

### SERGE VOLTAGE PREVENTION CIRCUIT

1. When the engine is stopped (key switch: OFF), current from key switch terminal M is disconnected and the battery relay is turned OFF.
2. The engine continues to rotate due to inertia force just after the key switch is turned OFF so that the alternator continues to generate electricity.
3. As the generating current cannot flow to the battery, surge voltage arises in the circuit and failures of the electronic components, such as the controller, possibly cause. In order to prevent the occurrence of surge voltage, the surge voltage prevention circuit is provided.
4. When the alternator is generating electricity, generating current from alternator terminal L flows to monitor unit terminal #C7. The monitor unit connects terminal #A12 to ground.
5. Current flows through the load damp relay exciting circuit and the load damp relay is turned ON.
6. Accordingly, even if the key switch is turned OFF while the engine is rotating, battery current continues to excite the battery relay through the load damp relay.
7. When the alternator stops generating, the battery relay is turned OFF.

# SYSTEM / Electrical System

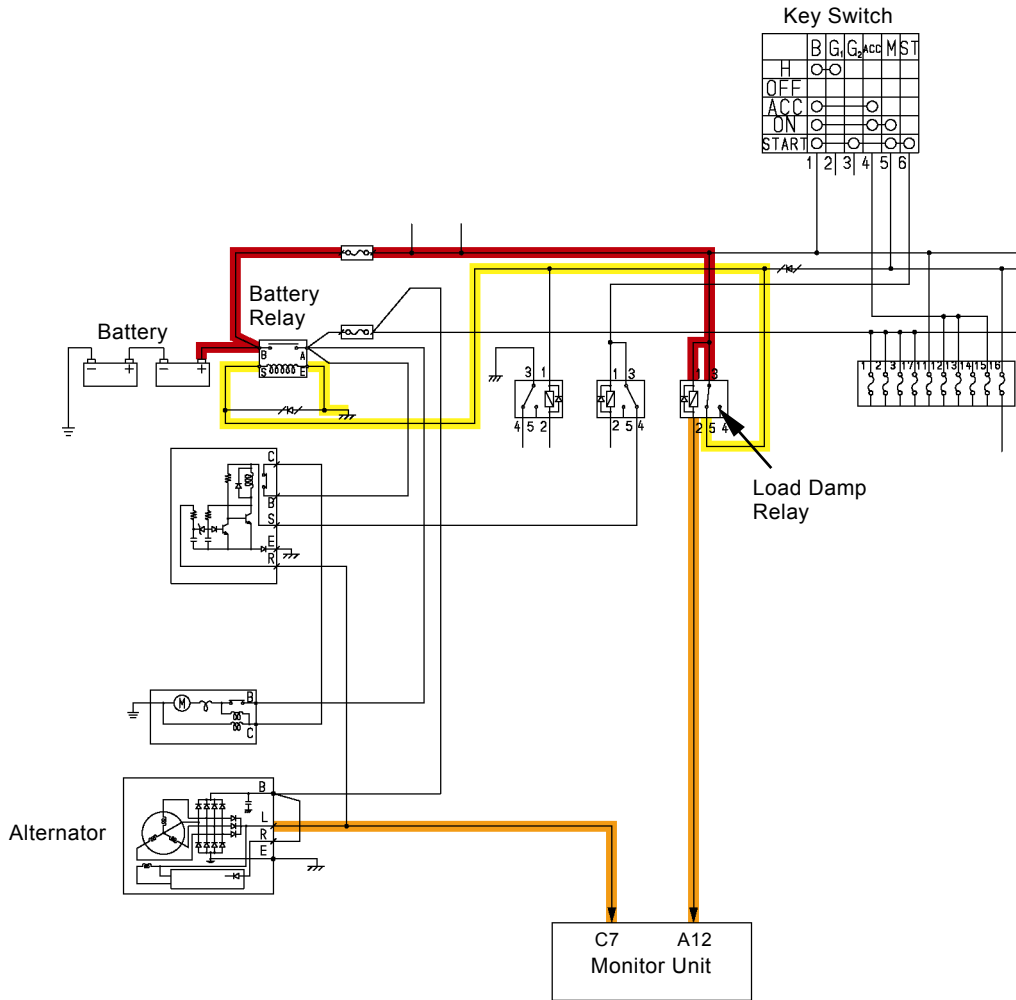

T1J1-02-05-005

## SYSTEM / Electrical System

---

### PILOT SHUT-OFF CIRCUIT (KEY SWITCH: ON)

1. When the pilot shut-off lever is turned to the UNLOCK position, the pilot shut-off switch is turned ON.
2. Electrical current from fuse #4 flows to the ground through the pilot shut-off relay and pilot shut-off switch so that the pilot shut-off relay is excited.
3. At the same time, the starter cut relay is connected to the ground circuit.
4. When the pilot shut-off relay is excited, the ground in pilot shut-off solenoid valve is connected to the ground through the pilot shut-off relay and security relay.
5. Therefore, the pilot shut-off solenoid valve is turned ON, pressure oil from the pilot pump is routed to the pilot valve.
6. When the key switch is turned to the START position, the starter cut relay is excited.
7. When the starter cut relay is excited, the circuit between terminal ST in the key switch and terminal S in starter relay 2 is blocked.
8. Therefore, when the pilot shut-off lever is in the UNLOCK position the key switch is turned to the START position, the engine does not start.

# SYSTEM / Electrical System

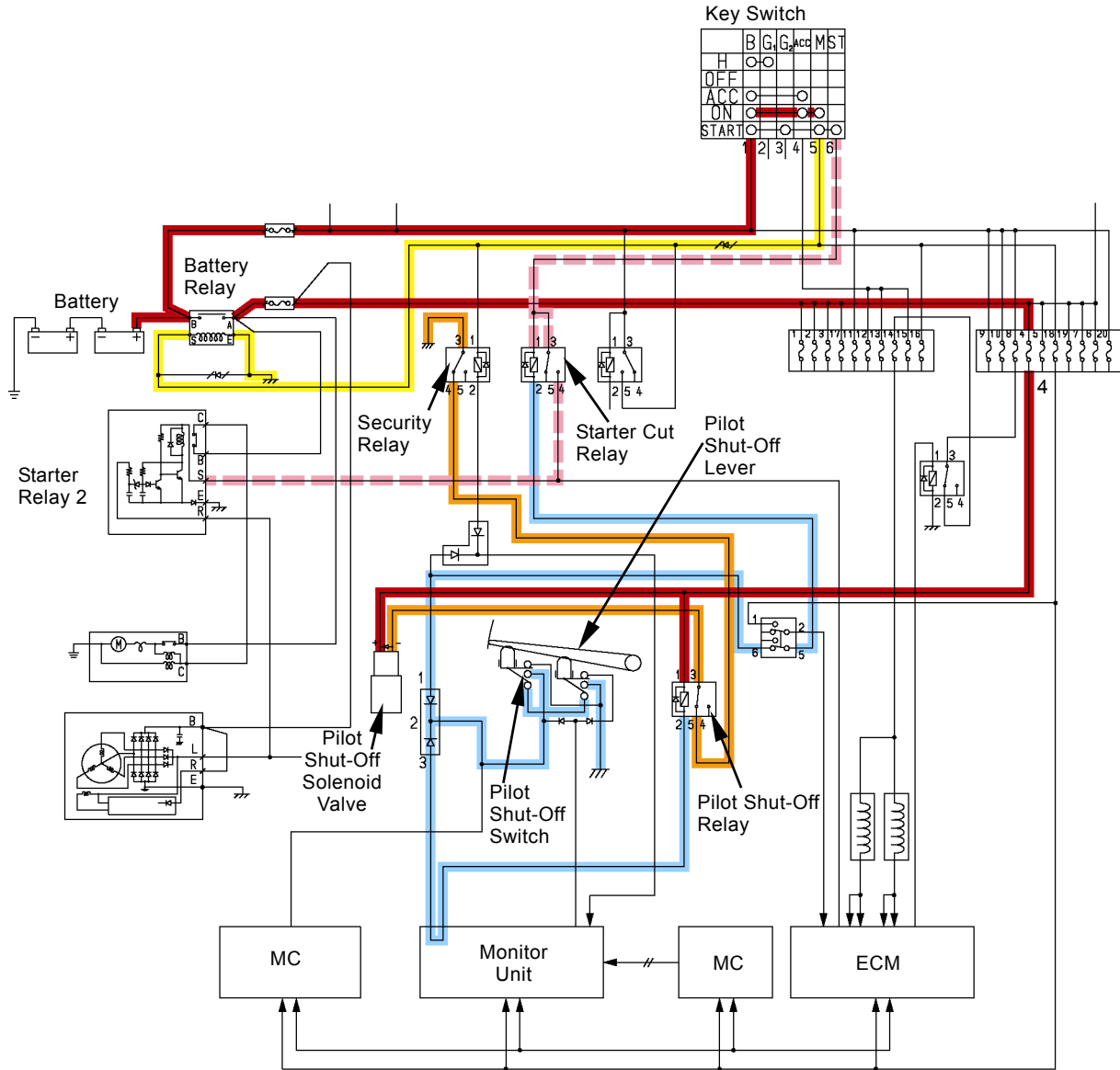

T1J1-02-05-006

## SYSTEM / Electrical System

---

### SECURITY LOCK CIRCUIT

1. When the external alarm signal or password input error signal from ICF is input to the monitor unit, terminal #A4 is connected to the ground inside the monitor unit.
2. Therefore, the security relay and starter cut relay are excited.
3. When the security relay is excited, the ground circuit in pilot shut-off solenoid valve is blocked and the pilot shut-off solenoid valve is turned OFF.
4. Therefore, pressure oil which flows to the pilot valve from the pilot pump is blocked by the pilot shut-off solenoid valve.
5. When the starter cut relay is excited, the circuit between terminal ST in the key switch and terminal S in starter relay 2 is blocked.
6. Therefore, when the key switch is turned to the START position, the engine does not start.

# SYSTEM / Electrical System

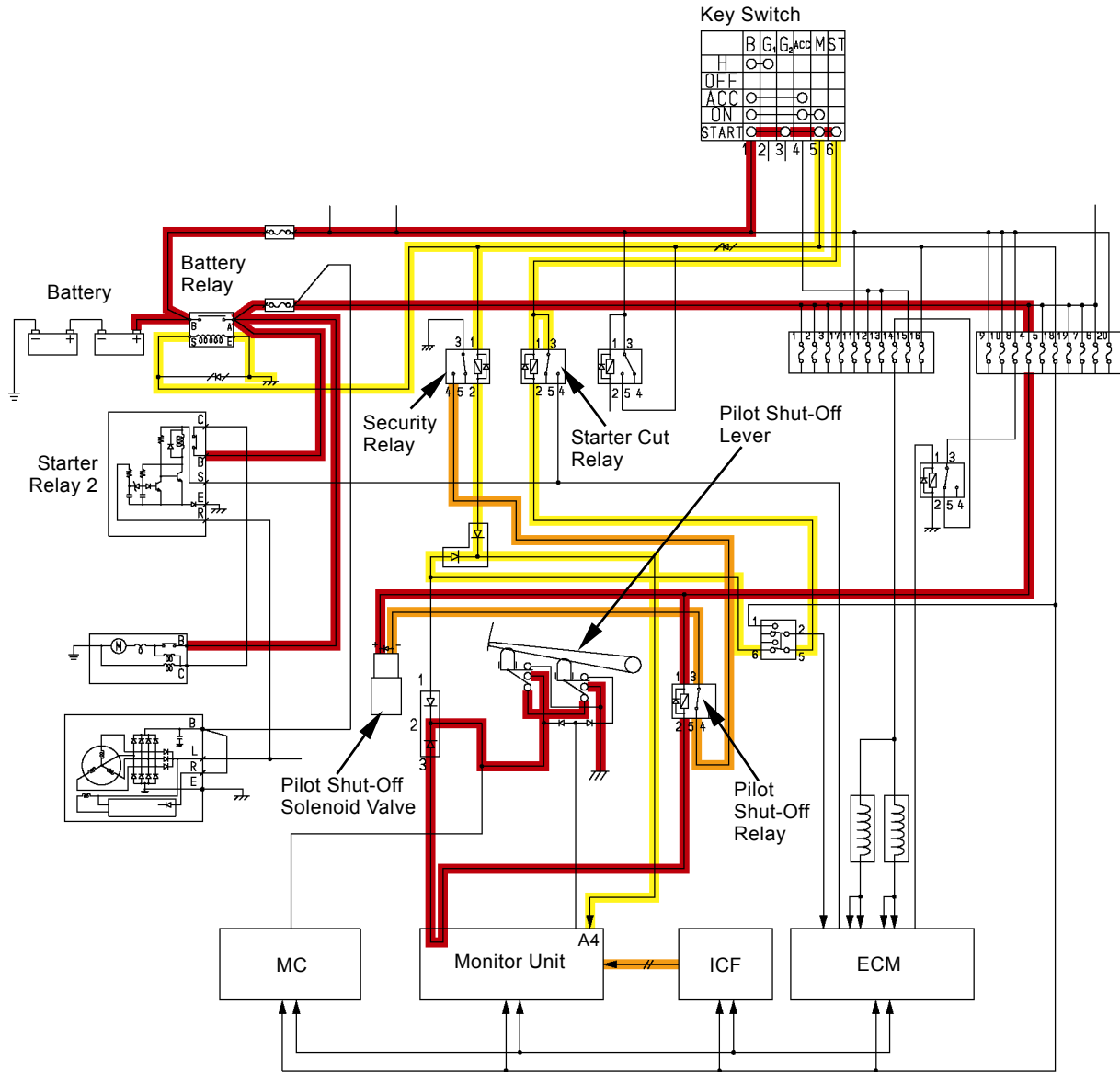

T1J1-02-05-007



## SYSTEM / Electrical System

---

### ENGINE STOP CIRCUIT (KEY SWITCH: OFF)

1. When the key switch is turned from the ON position to the OFF position, the signal current indicating that the key switch is ON stops flowing from terminal M to ECM terminal #V24.
2. ECM stops injection of injector and the engine stops.
3. When the engine stops, ECM turns the ECM main relay OFF.

# SYSTEM / Electrical System

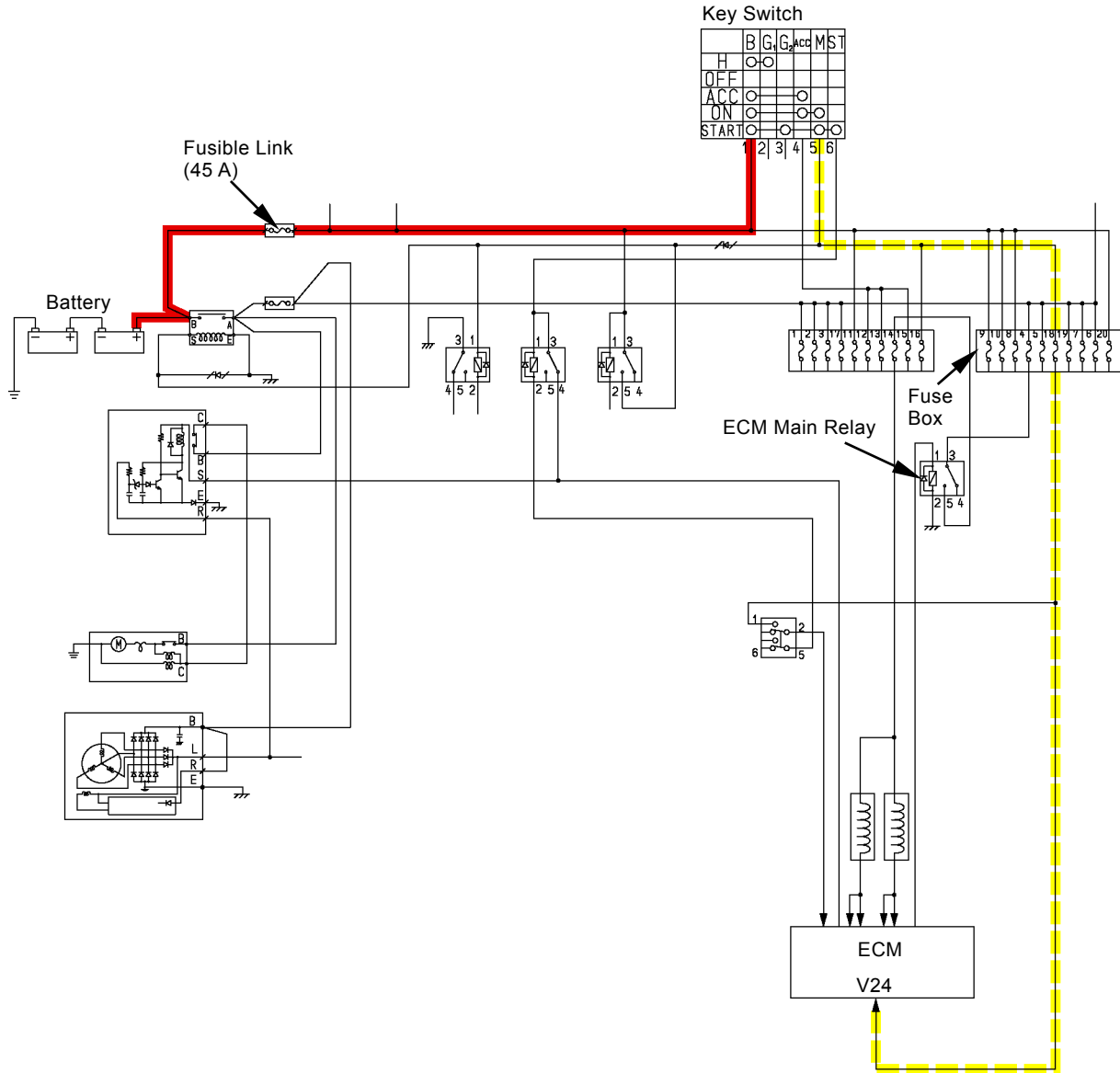

T1J1-02-05-008

## SYSTEM / Electrical System

### SECURITY HORN CIRCUIT

1. When the external alarm signal or password input error signal from ICF is input to the monitor unit, terminal #A3 is connected to the ground inside the monitor unit.
2. Therefore, the security horn relay is excited.
3. When the security horn relay is excited, electrical current from fuse #9 operates the security horn.

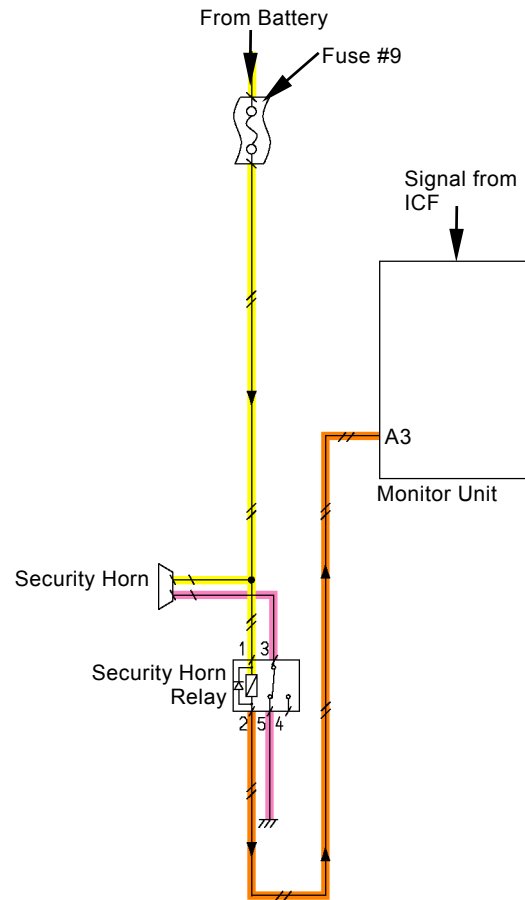

T1V1-02-05-006

## SYSTEM / Electrical System

---

(Blank)

## SYSTEM / Electrical System

---

### WORKING LIGHT CIRCUIT

#### Working Light and Cab Light Circuit

1. When the working light switch moves to position 1, monitor unit terminal #B20 receives the signal.
2. Terminal #A1 is connected to the ground inside the monitor unit.
3. Therefore, light relay 1 is excited, current from fuse #29 flows to the working light and cab light, and turns on the working light and cab light.

#### Boom Light Circuit

1. When the working light switch moves to position 2, monitor unit terminal #A6 receives the signal.
2. Terminal #A5 is connected to the ground inside the monitor unit.
3. Therefore, light relay 2 is excited, current from fuse #1 flows to the boom light, and turns on the boom light.

# SYSTEM / Electrical System

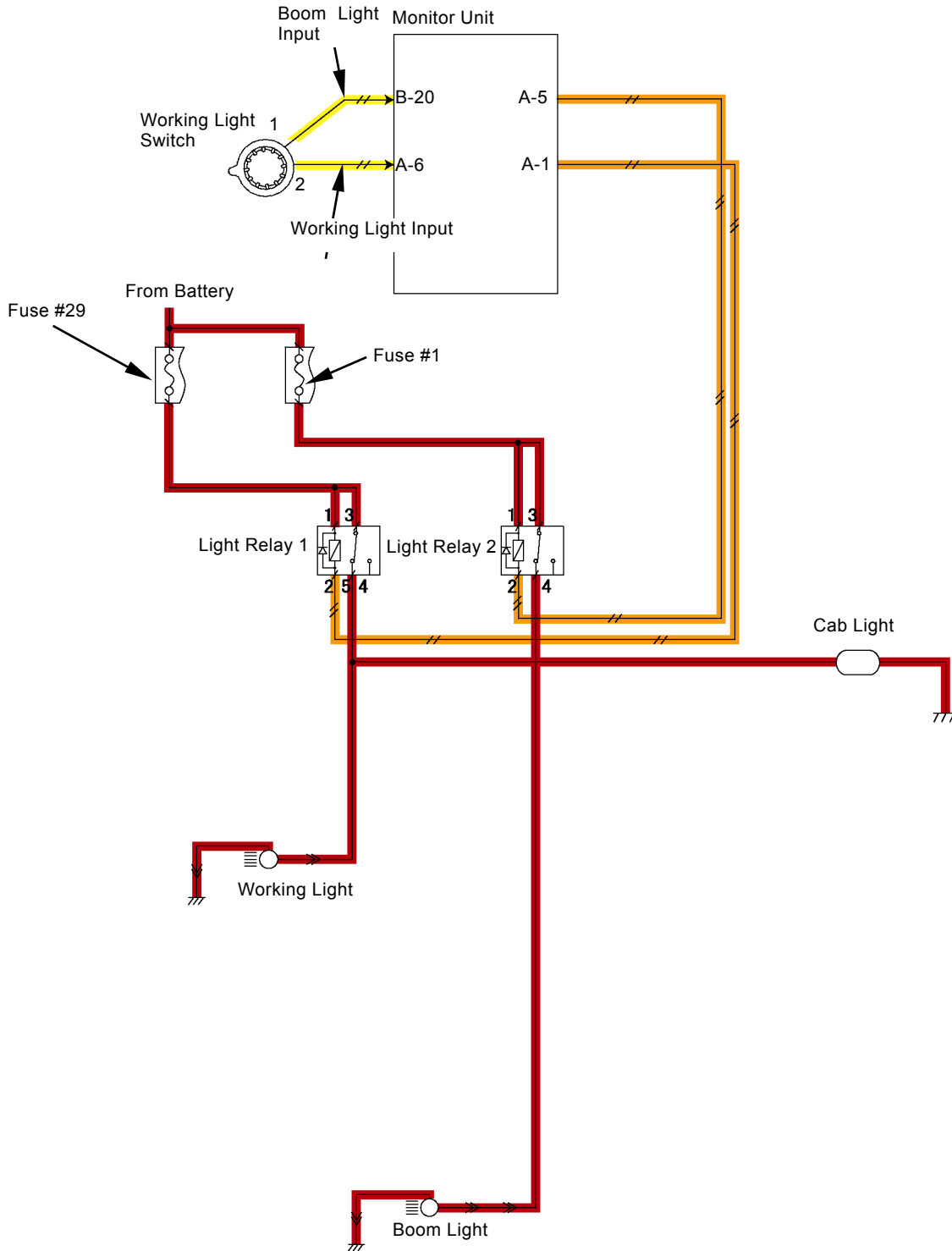

T1J1-02-05-009

# SYSTEM / Electrical System

## WIPER / WASHER CIRCUIT

### Wiper Circuit

Operation:

1. The wiper / washer switch sends the electrical signal on position the INT. in response to the set intervals to the monitor unit.
2. The monitor unit connects terminal #A2 to the ground according to the input intervals.
3. Therefore, the wiper relay repeats to turn ON and OFF.
4. When the wiper relay is turned ON, current from fuse #2 flows to the wiper motor and the wiper moves.

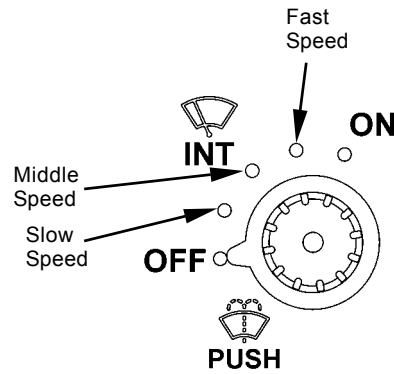

### Washer Operation

M178-01-016

Operation:

1. While pushing the wiper/washer switch, the monitor unit receives the electrical signal from the wiper/washer switch.
2. The monitor unit connects terminal #A10 to the ground and the washer relay is excited.
3. Current from fuse #2 flows to the washer motor and washer liquid jets.

Position ITN.	Set Time
Slow	8 seconds
Middle	6 seconds
Fast	3 seconds

# SYSTEM / Electrical System

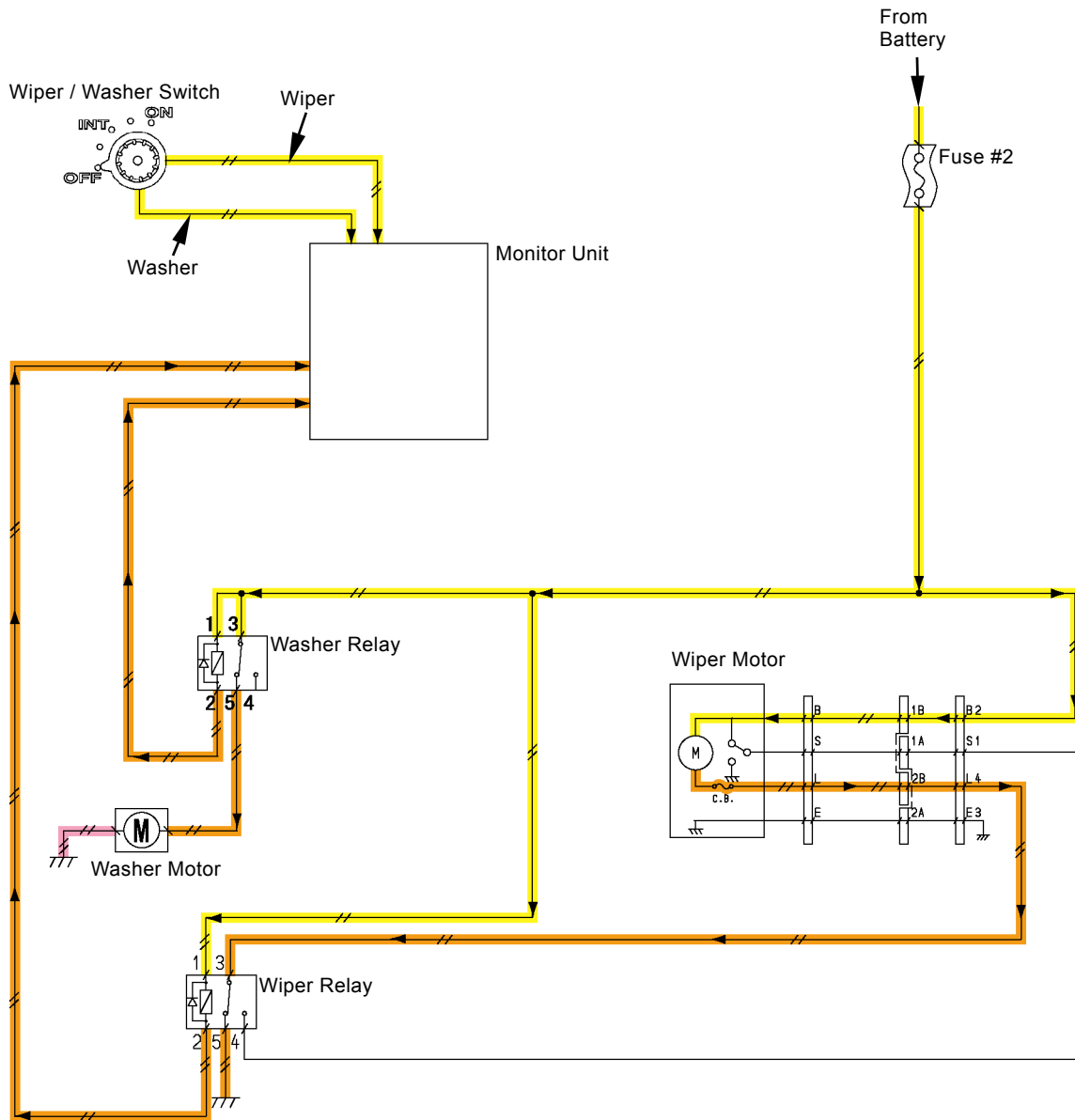

T1V1-02-05-005



## SYSTEM / Electrical System

---

(Blank)





---

# SECTION 3 COMPONENT OPERATION

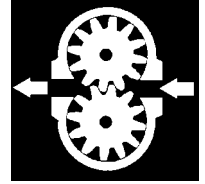

## CONTENTS

### Group 1 Pump Device

Outline .....	T3-1-1
Main Pump, Fan Pump .....	T3-1-2
Regulator for Main Pump .....	T3-1-4
Regulator for Fan Pump .....	T3-1-12
Pump 1, 2 Control Solenoid Valve	
Fan Pump Control Solenoid Valve .....	T3-1-28
Pilot Pump .....	T3-1-30
Pump Delivery Pressure Sensor .....	T3-1-30
Pump Regulator Pressure	
(Flow Rate Control Pressure) Sensor ...	T3-1-30

### Group 2 Swing Device

Outline .....	T3-2-1
Swing Reduction Gear .....	T3-2-2
Swing Motor .....	T3-2-3
Swing Parking Brake .....	T3-2-4
Valve Unit .....	T3-2-6

### Group 3 Control Valve

Outline .....	T3-3-1
Hydraulic Circuit .....	T3-3-16
Main Relief Valve .....	T3-3-20
Overload Relief Valve	
(with Make-Up Function) .....	T3-3-22
Boom Overload Relief Control Valve .....	T3-3-24
Flow Combiner Valve .....	T3-3-26
Anti-Drift Valve .....	T3-3-28
Regenerative Valve .....	T3-3-32
Flow Rate Control Valve .....	T3-3-36
Bypass Shut-Out Valve .....	T3-3-40

### Group 4 Pilot Valve

Outline .....	T3-4-1
Operation .....	T3-4-4
Shockless Function	
(Only for Travel Pilot Valve) .....	T3-4-14

### Group 5 Travel Device

Outline .....	T3-5-1
Travel Reduction Gear .....	T3-5-2
Travel Motor .....	T3-5-3
Travel Brake Valve .....	T3-5-5
Parking Brake .....	T3-5-12

### Group 6 Signal Control Valve

Outline .....	T3-6-1
Pilot Port .....	T3-6-2
Shuttle Valve .....	T3-6-6
Shockless Valve .....	T3-6-10
Arm Flow Rate Control Valve Control Spool,	
Flow Combiner Valve Control Spool,	
Swing Parking Brake Release Spool .....	T3-6-14

---

---

**Group 7 Others (Upperstructure)**

Pilot Shut-Off Solenoid Valve.....	T3-7-1
4-Spool Solenoid Valve Unit .....	T3-7-3
Pilot Relief Valve .....	T3-7-5
Fan Motor .....	T3-7-6
Fan Valve .....	T3-7-7
Shockless Valve .....	T3-7-8
Accumulator .....	T3-7-9
Distribution Valve (Optional) .....	T3-7-10

**Group 8 Others (Undercarriage)**

Swing Bearing .....	T3-8-1
Center Joint.....	T3-8-2
Track Adjuster .....	T3-8-3

## COMPONENT OPERATION / Pump Device

### OUTLINE

The pump device consists of transmission, main pumps (1, 2), pilot pump and fan pump.

The engine output is transmitted to the transmission via the shaft. After being distributed by the gear, the engine power drives the pumps respectively. The reduction gear ratio of engine and main pumps 1 and 2 are 1:53/57, engine and fan pump and pilot pump are 1:1.

The main pump is a swash plate type variable displacement plunger pump.

The two main pumps arranged in right and left supply high pressure oil for work to the main circuit.

The pilot pump is a gear pump and supplies pressure oil to the pilot circuit.

The fan pump is a swash plate type variable displacement plunger pump and supplies pressure oil to the fan motor.

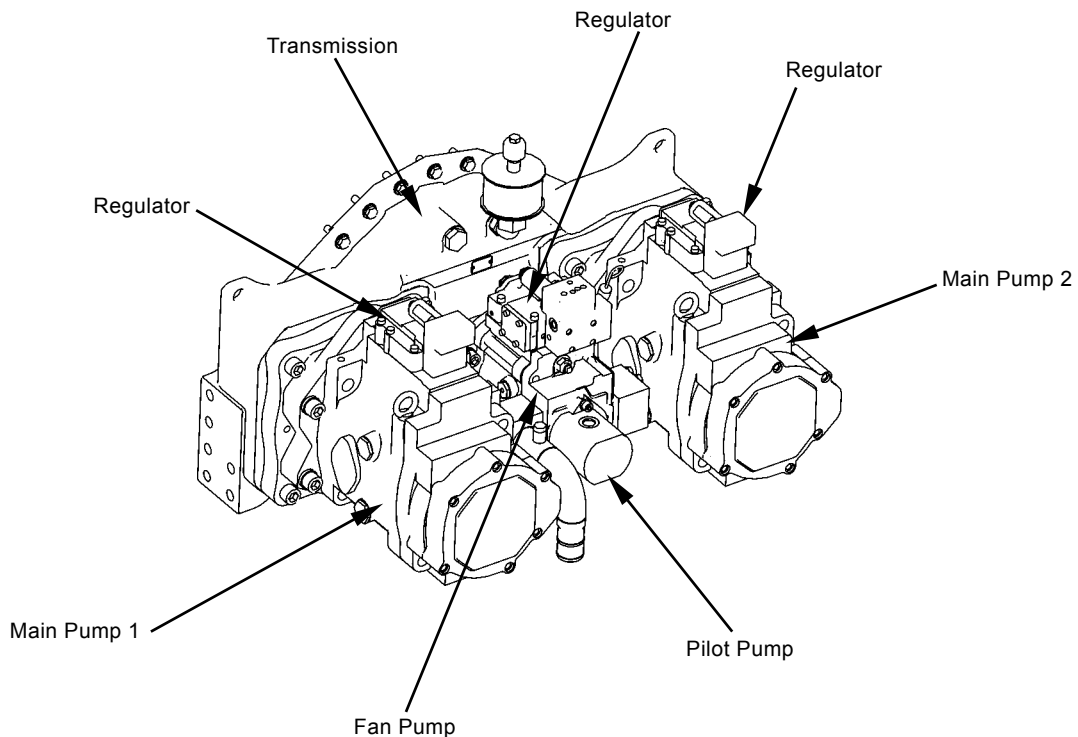

T1JB-03-01-003

# COMPONENT OPERATION / Pump Device

## MAIN PUMP, FAN PUMP

The main pump and fan pump are swash plate type variable displacement plunger pump.

Shaft (1) is splined to cylinder block (3). Plunger (2) is inserted into cylinder block (3).

The engine output is transmitted to shaft (1) via the pump transmission.

When shaft (1) rotates, plunger (2) rotates with cylinder block (3) together. Plunger (2) slides on shoe plate (4) and reciprocates in the bore of cylinder block (3) due to inclination of swash plate (5). By this reciprocation, suction and delivery of hydraulic oil are carried out.

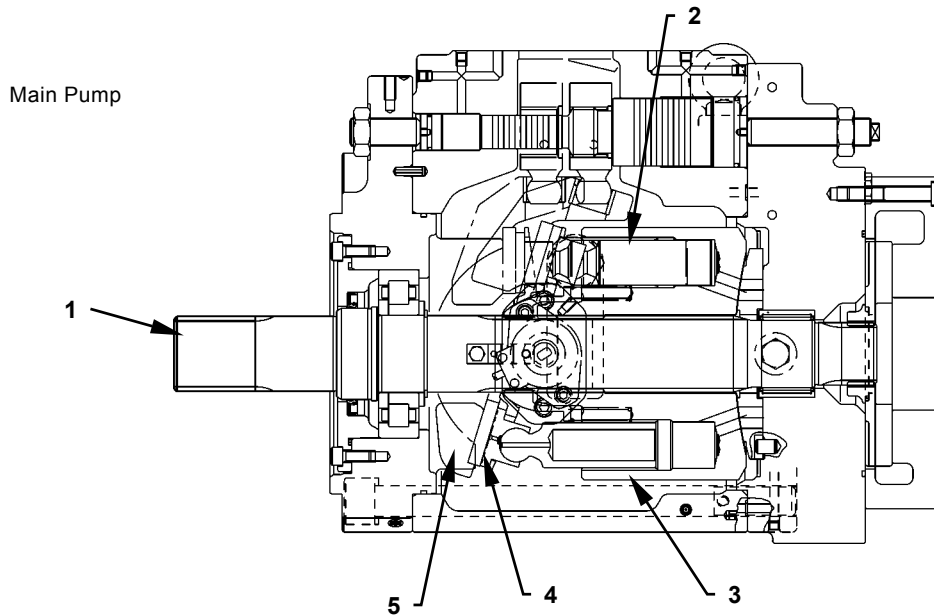

T1JB-03-01-002

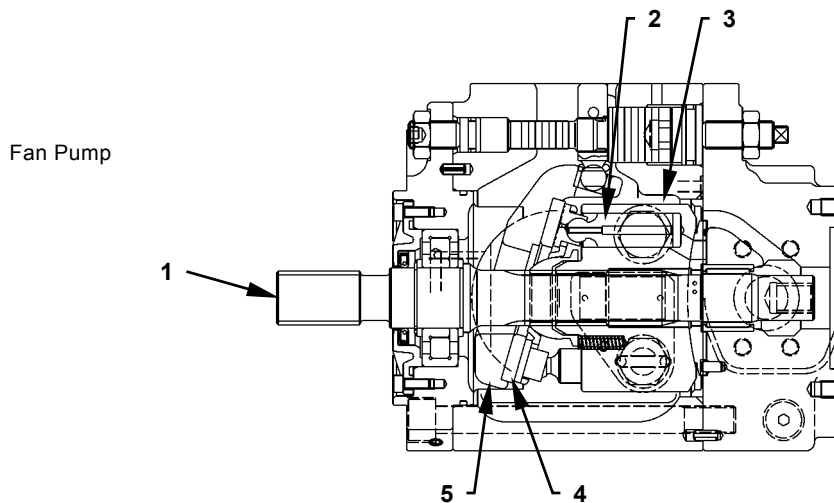

T1J1-03-01-003

1 - Shaft  
2 - Plunger

3 - Cylinder Block

4 - Shoe Plate

5 - Swash Plate

## COMPONENT OPERATION / Pump Device

---

### Delivery Rate Increase/Decrease Operation

The main pump delivery rate is changed by changing the swash plate (3) angle (displacement angle) and changing plunger stroke.

Servo piston (2) is moved by pressure oil from the regulator and the swash plate (3) angle (displacement angle) is controlled.

As swash plate (3) is connected to servo piston (2), the swash plate (3) angle is changed by the movement of servo piston (2).

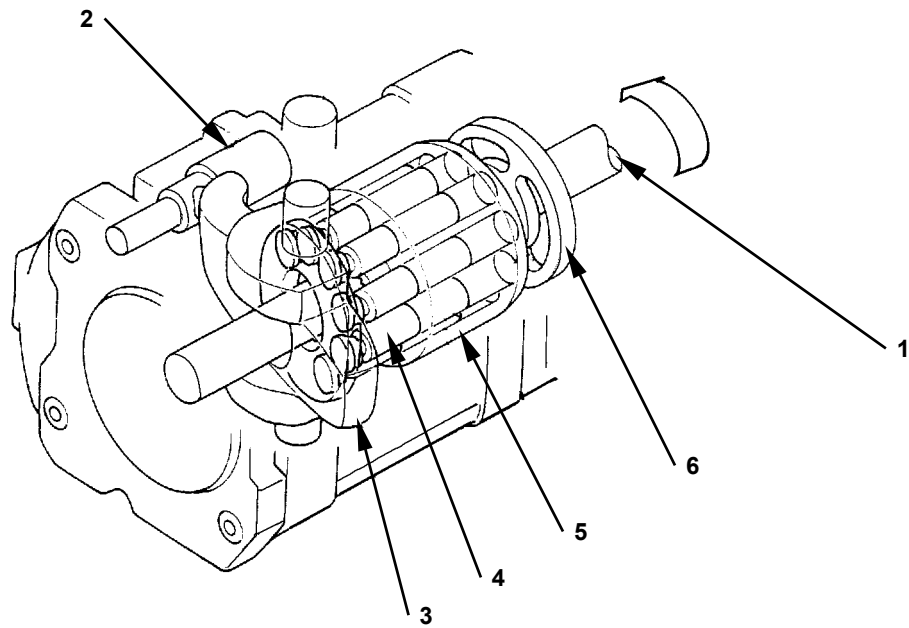

T142-02-01-001

1 - Shaft  
2 - Servo Piston

3 - Swash Plate  
4 - Plunger

5 - Cylinder Block

6 - Valve Plate





## COMPONENT OPERATION / Pump Device

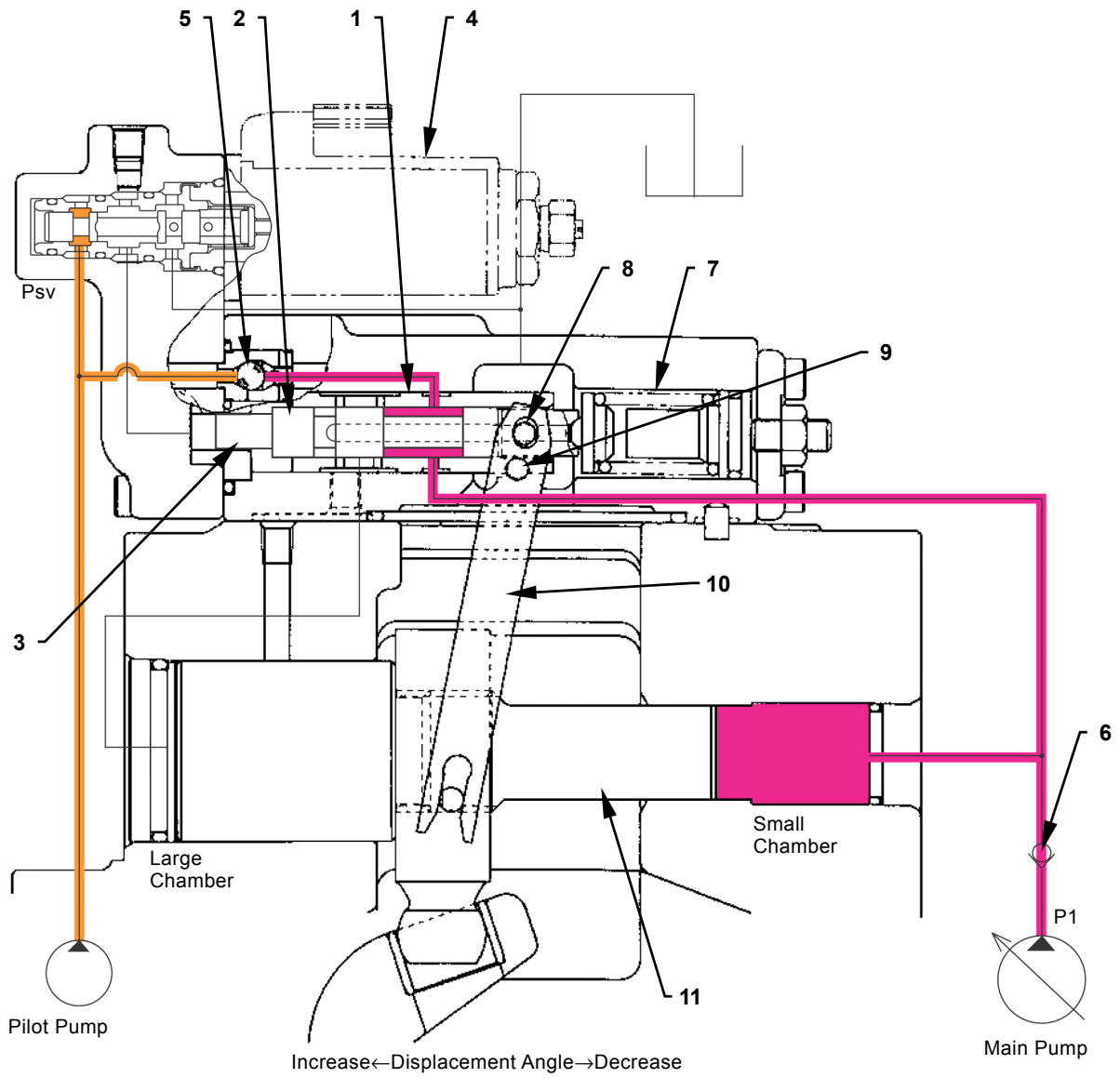

T1J1-03-01-024

- |                  |                                 |            |                     |
|------------------|---------------------------------|------------|---------------------|
| 1 - Sleeve       | 4 - Pump Control Solenoid Valve | 7 - Spring | 10 - Feedback Lever |
| 2 - Spool        | 5 - Check Valve                 | 8 - Pin    | 11 - Servo Piston   |
| 3 - Pilot Piston | 6 - Check Valve                 | 9 - Pin    |                     |

## COMPONENT OPERATION / Pump Device

### Control by Flow Rate Control Pressure of Pump Control Solenoid Valve

- Minimum Flow Rate (Regulator Operation with Flow Rate Control Pressure 0)
1. When flow rate control pressure from pump control solenoid valve (4) is 0, spool (2) is pushed to the left by spring (7).
  2. As a result, own pump delivery pressure P1 is routed into the large chamber in servo piston (11) through check valve (6), sleeve (1) and spool (2). Although own pump delivery pressure P1 is also routed into the small chamber in servo piston (11), servo piston (11) moves to the right due to the difference in pressure receiving areas.
  3. As servo piston (11) moves, feedback lever (10) rotates counterclockwise around pin (9).
  4. As the top end of feedback lever (10) is connected to sleeve (1) by pin (8), sleeve (1) moves to the left.
  5. With the above operation, the pump displacement angle becomes the minimum so that pump delivery flow rate become minimum.

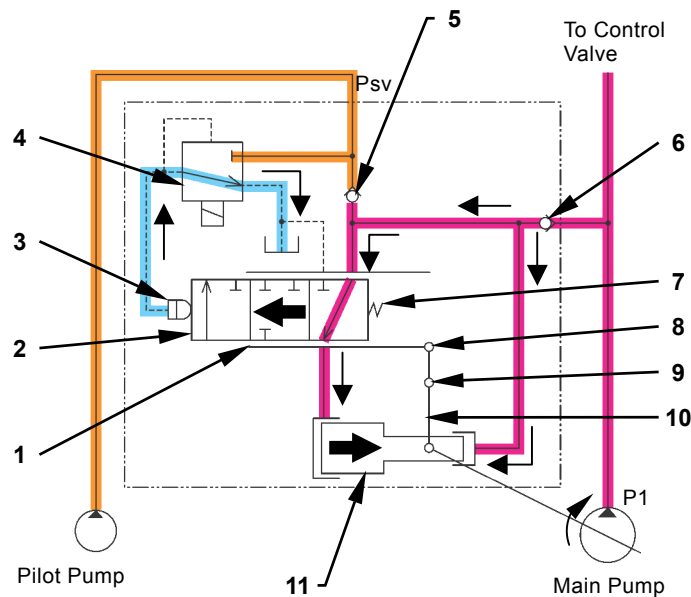

T1J1-03-01-005

# COMPONENT OPERATION / Pump Device

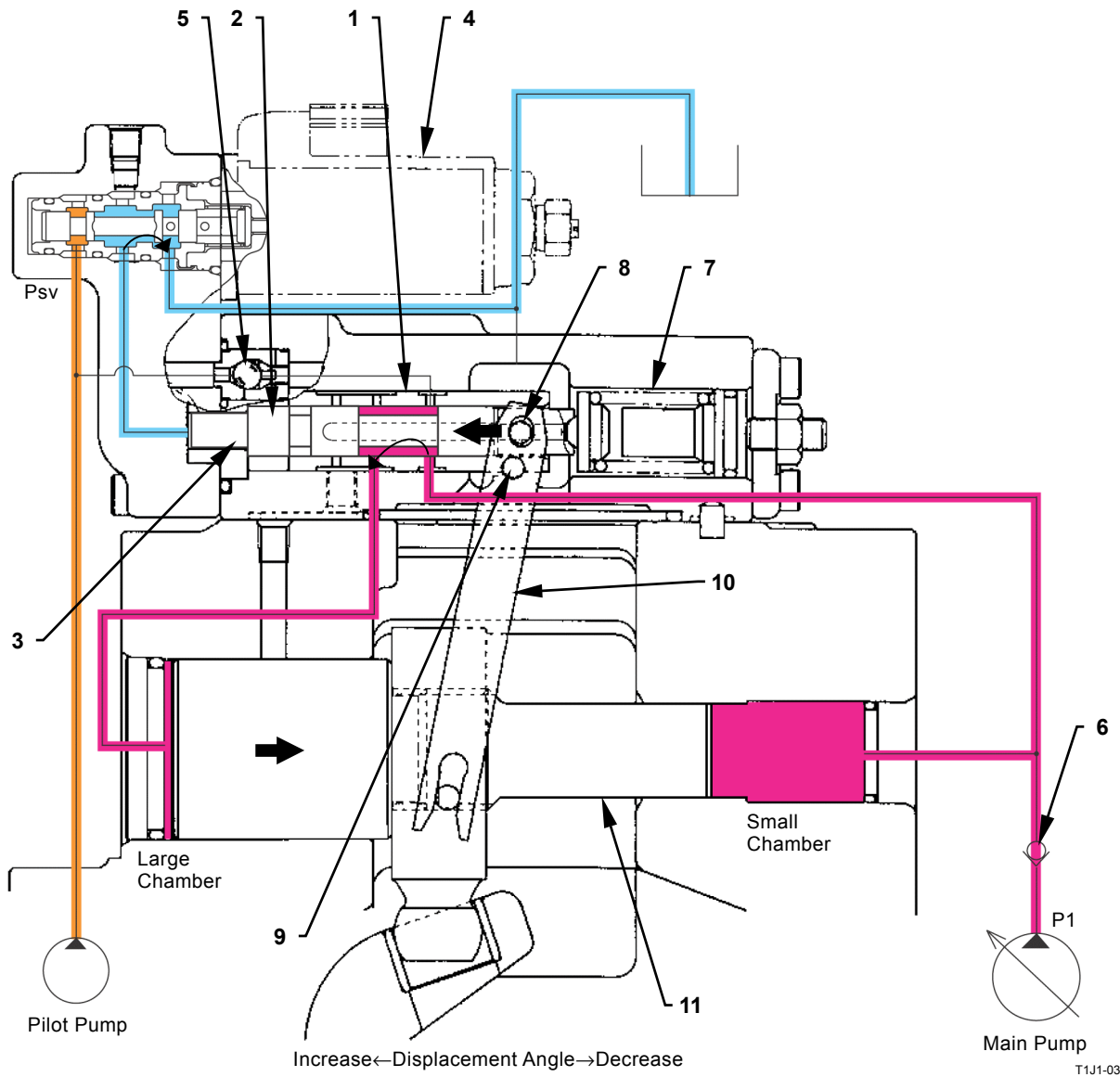

T1J1-03-01-025

## COMPONENT OPERATION / Pump Device

• Increasing Flow Rate (Regulator Operation with Flow Rate Control Pressure Increasing)

1. When pump control solenoid valve (4) is actuated, flow rate control pressure  $P_i$  in proportion to the movement of pump control solenoid valve (4) acts on pilot piston (3) and moves spool (2) to the right until spool (2) balances with spring (7).
2. When spool (2) moves to the right, the large chamber of servo piston (11) is connected to the hydraulic oil tank through passage in spool (2).
3. As own pump delivery pressure  $P_1$  is routed into the small chamber of servo piston (11) all the time, servo piston (11) moves to the left and oil in the large chamber is returned to the hydraulic oil tank.
4. As servo piston (11) moves to the left, feedback lever (10) rotates clockwise around pin (9).
5. As the top end of feedback lever (10) is connected to sleeve (1) by pin (8), sleeve (1) moves to the right.
6. Servo piston (11) continues to move until the notches on sleeve (1) and spool (2) are closed completely.
7. With the above operation, the pump displacement angle is increased, and pump delivery flow rate increases. Increasing amount of pump delivery flow rate is proportional to the that of flow rate control pressure  $P_i$ .

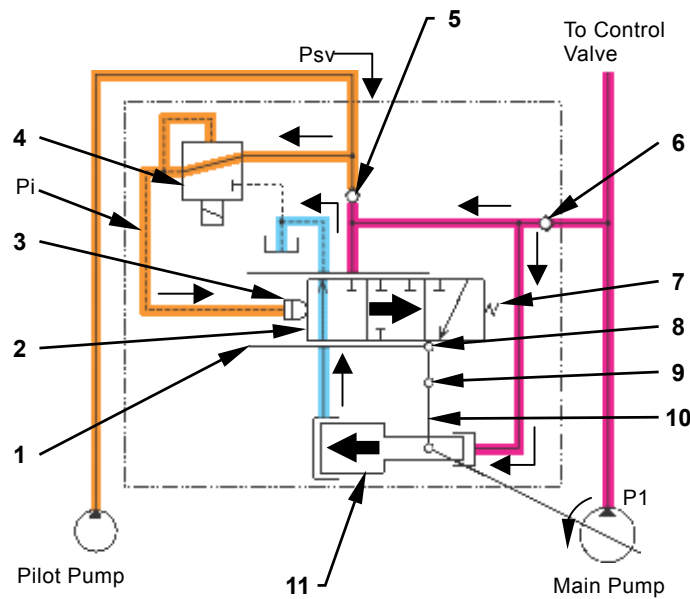

T1J1-03-01-006

# COMPONENT OPERATION / Pump Device

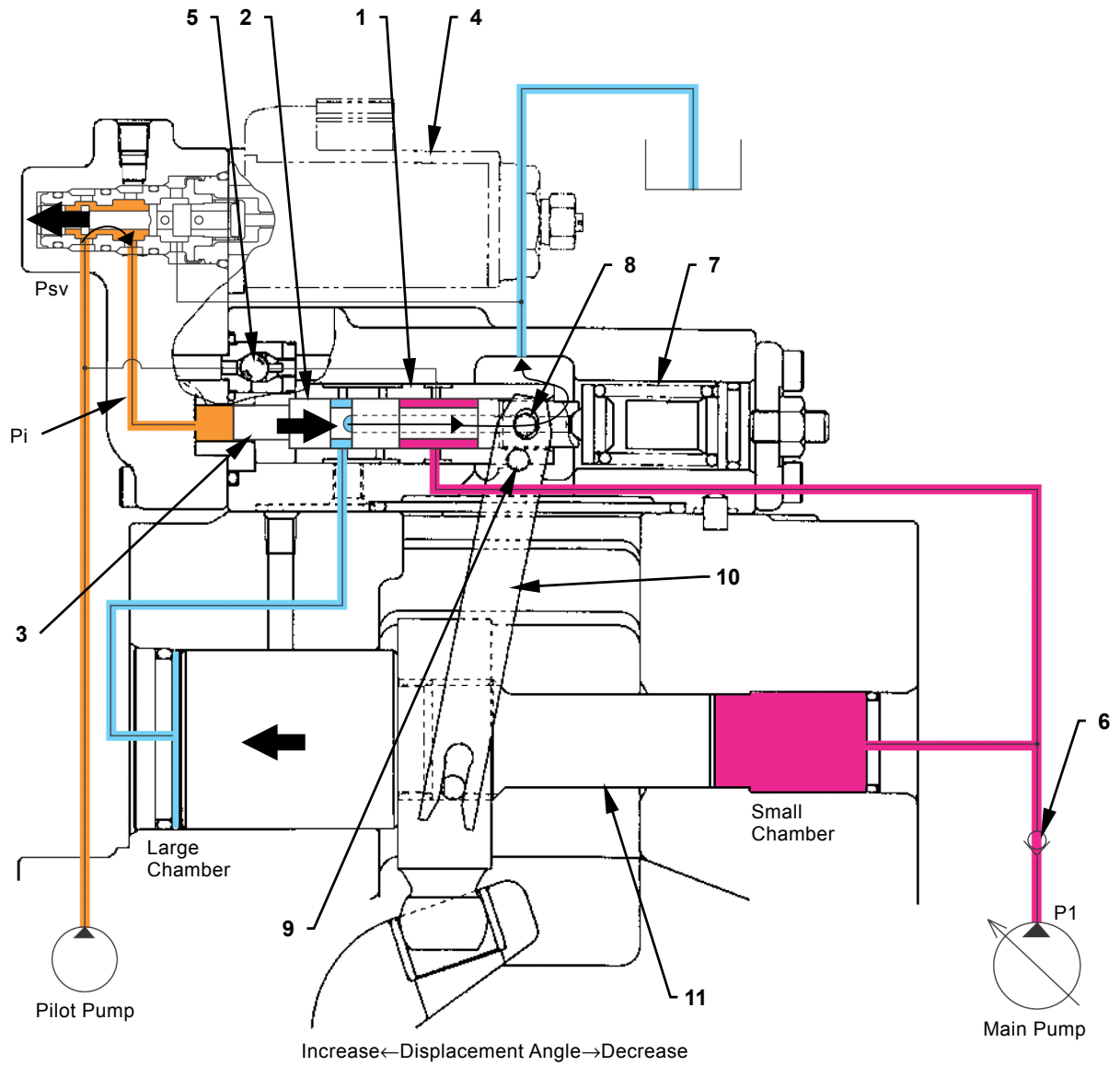

T1J1-03-01-026

## COMPONENT OPERATION / Pump Device

• Decreasing Flow Rate (Regulator Operation with Flow Rate Control Pressure Decreasing)

1. When flow rate control pressure  $P_i$  from pump control solenoid valve (4) decreases, spool (2) is returned to the left until spool (2) balances with spring (7).
2. Pressure oil acting on pilot piston (3) is returned to the hydraulic oil tank via through pump control solenoid valve (4).
3. As spool (2) moves to the left, own pump delivery pressure  $P_1$  is routed into the large chamber in servo piston (11) through check valve (6), sleeve (1) and spool (2).

Although own pump delivery pressure  $P_1$  is also routed into the small chamber in servo piston (11), servo piston (11) moves to the right due to the difference in pressure receiving areas.

4. As servo piston (11) moves to the right, feedback lever (10) rotates counterclockwise around pin (9).
  5. As the top end of feedback lever (10) is connected to sleeve (1) by pin (8), sleeve (1) moves to the left.
- Servo piston (11) continues to move until the notches on sleeve (1) and spool (3) are closed completely.
6. With the above operation, the pump displacement angle is reduced and pump delivery flow rate decreases. Decreasing amount of pump delivery flow rate is proportional to that of flow rate control pressure  $P_i$ .

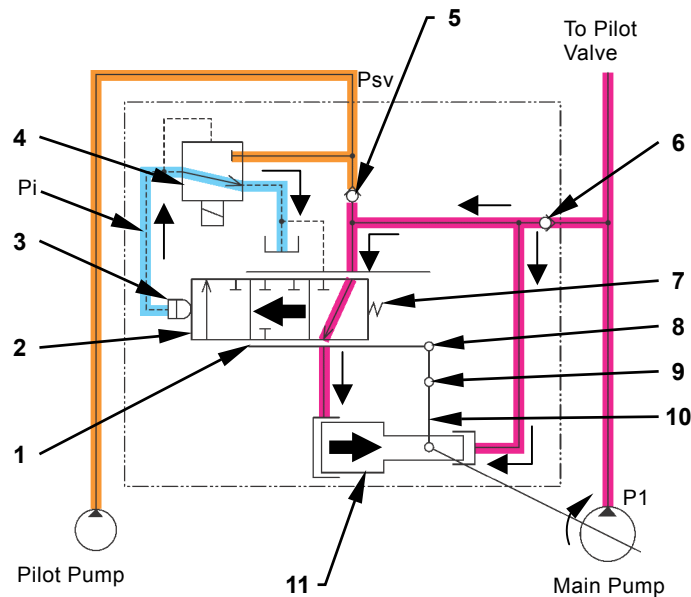

T1J1-03-01-005

# COMPONENT OPERATION / Pump Device

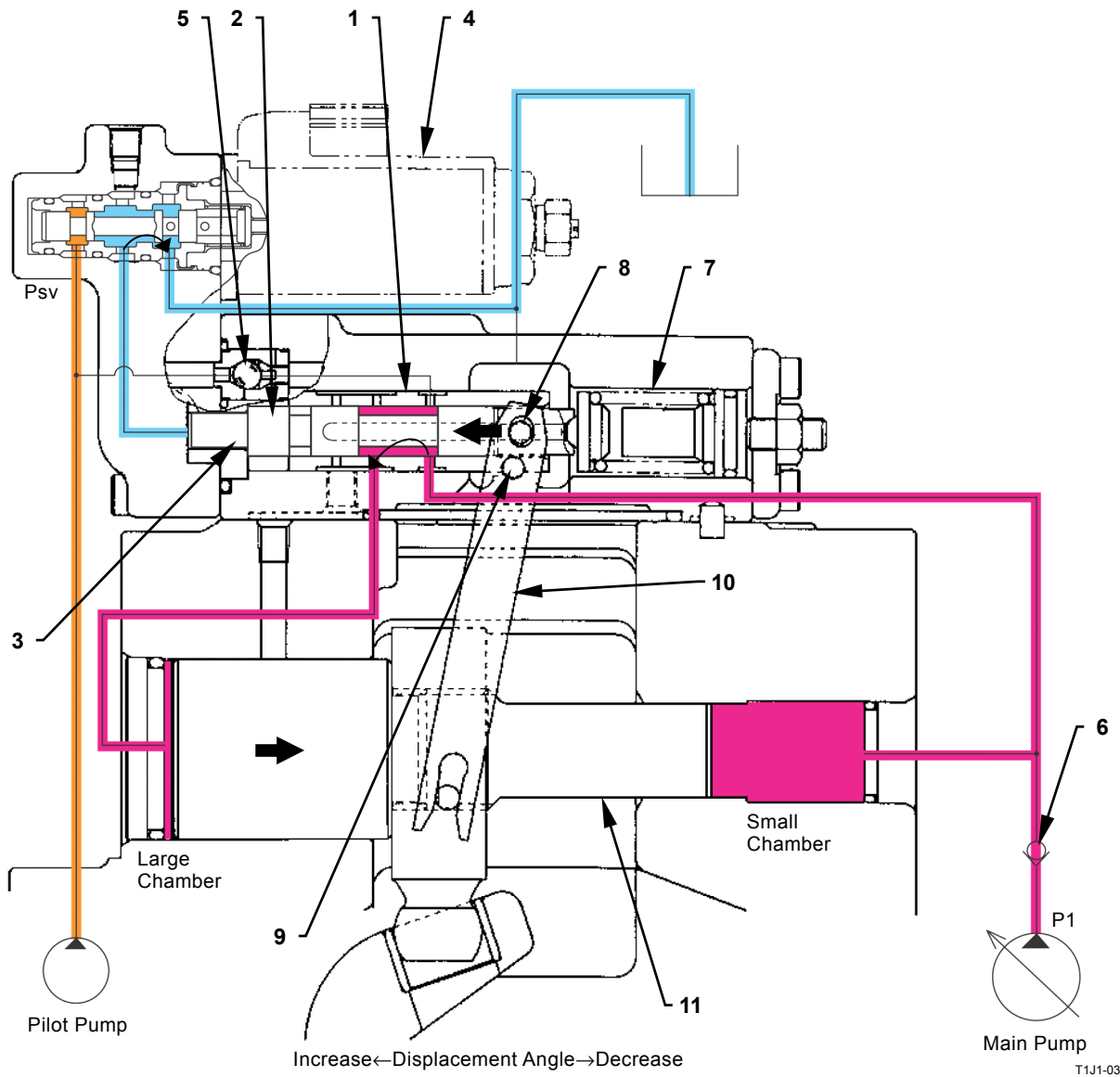

T1J1-03-01-025



## COMPONENT OPERATION / Pump Device

### REGULATOR FOR FAN PUMP

The regulator is provided on the top of the fan pump and control the fan pump delivery flow rate. Pump delivery flow rate is controlled as flow rate control pressure from fan pump control solenoid valve (17) increases or decreases.

Own pump delivery pressure  $P_3$  is routed to compensating piston (1), spool (2) and the small chamber in servo piston (15) all the time.

As fan pump control solenoid valve (17) is activated, pilot pressure  $P_r$  from the pilot pump is reduced and acts on pilot piston (22) as flow control pressure  $P_i$ .

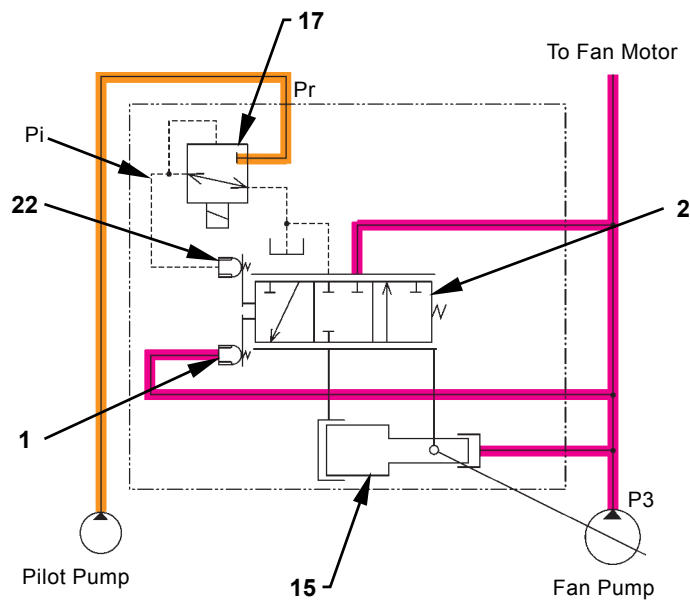

T1J1-03-01-013

# COMPONENT OPERATION / Pump Device

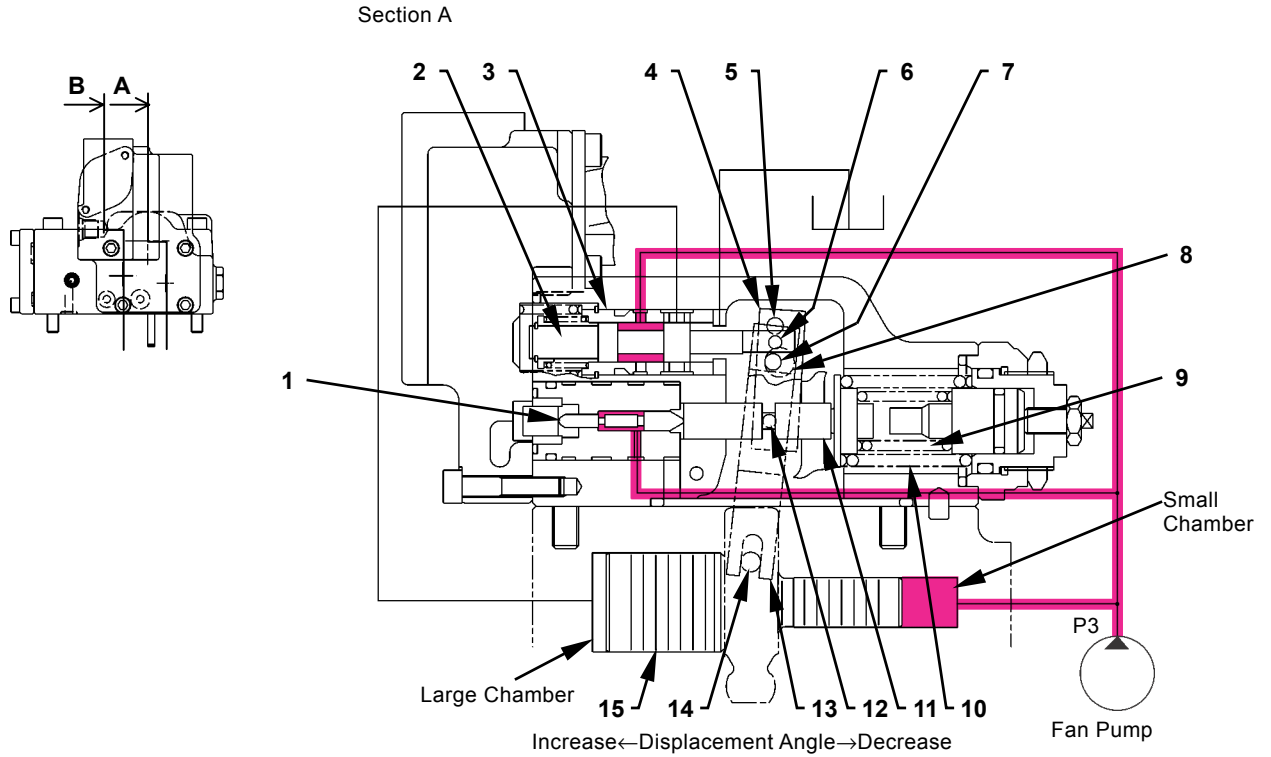

Section B

T1J1-03-01-011

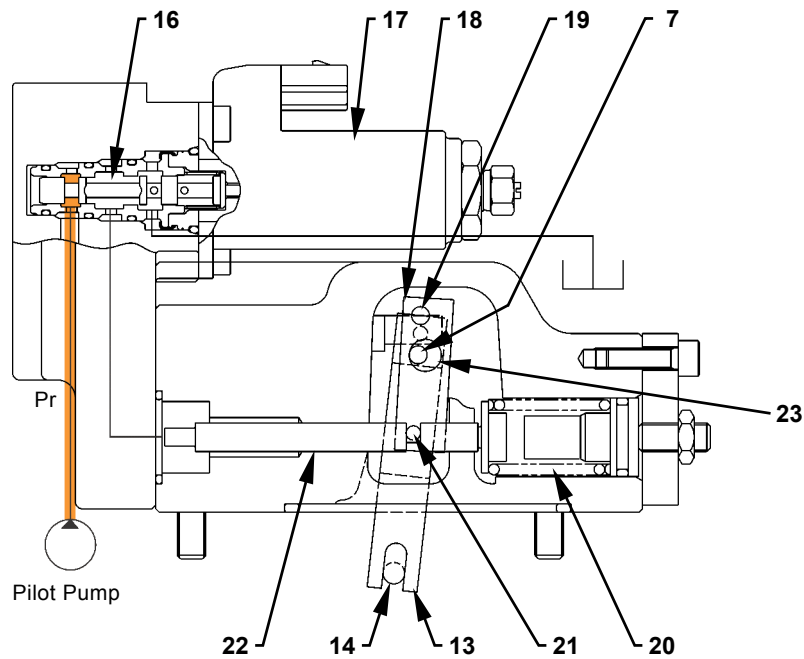

T1J1-03-01-012

- |                         |                       |                                      |                   |
|-------------------------|-----------------------|--------------------------------------|-------------------|
| 1 - Compensating Piston | 7 - Pin               | 13 - Feedback Lever                  | 19 - Pin          |
| 2 - Spool               | 8 - Hole              | 14 - Pin                             | 20 - Spring       |
| 3 - Sleeve              | 9 - Inner Spring      | 15 - Servo Piston                    | 21 - Pin          |
| 4 - Lever 2             | 10 - Outer Spring     | 16 - Spool                           | 22 - Pilot Piston |
| 5 - Pin                 | 11 - Compensating Rod | 17 - Fan Pump Control Solenoid Valve | 23 - Hole         |
| 6 - Pin                 | 12 - Pin              | 18 - Lever 1                         |                   |

## COMPONENT OPERATION / Pump Device

### Link Mechanism

- The movement of pilot piston (22) is transmitted through pin (21) to lever 1 (18). Lever 1 (18) is turned about pin (19) which is fixed to the axial plug.
- The movement of pilot piston (11) is transmitted through pin (12) to lever 2 (4). Lever 2 (4) is turned about pin (5) which is fixed to the housing.
- Pin (7) is attached to feedback lever (13). Both ends of pin (7) are inserted into holes (23, 8) on lever 1 (18) and lever 2 (4).
- Therefore, when lever 1 (18) or lever 2 (4) turns, pin (7) contacts the hole of the turned lever. Feedback lever (13) turns about pin (14) attached to servo piston (15).
- In addition, when servo piston (15) moves, feedback lever (13) is moved through pin (14).
- At this time, as neither lever 1 (18) nor lever 2 (4) move, feedback lever (13) turns about pin (7).

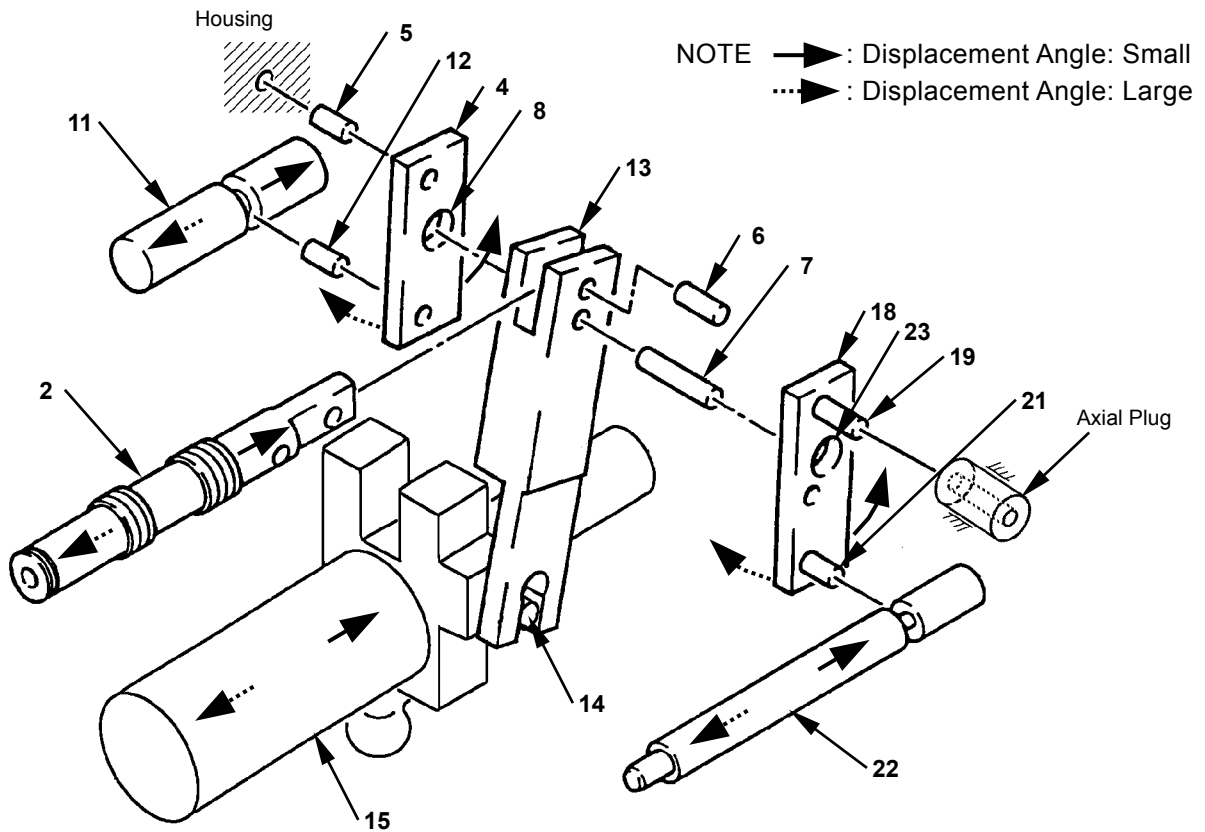

NOTE → : Displacement Angle: Small  
 ...→ : Displacement Angle: Large

- |             |                       |                     |                   |
|-------------|-----------------------|---------------------|-------------------|
| 2 - Spool   | 7 - Pin               | 13 - Feedback Lever | 19 - Pin          |
| 4 - Lever 2 | 8 - Hole              | 14 - Pin            | 21 - Pin          |
| 5 - Pin     | 11 - Compensating Rod | 15 - Servo Piston   | 22 - Pilot Piston |
| 6 - Pin     | 12 - Pin              | 18 - Lever 1        | 23 - Hole         |

T1J1-03-01-007

## COMPONENT OPERATION / Pump Device

---

(Blank)

## COMPONENT OPERATION / Pump Device

### Control by Flow Rate Control Pressure of Fan Pump Control Solenoid Valve

- Decreasing Flow Rate (Regulator Operation with Flow Rate Control Pressure Increasing)

- When fan pump control solenoid valve (17) is activated, flow rate control pressure  $P_i$  in proportion to the movement of fan pump control solenoid valve (17) is routed to pilot piston (22) through spool (16). When pilot pressure  $P_i$  increases, pilot piston (22) moves to the right until pilot piston (22) balances with spring (20).
- Pilot piston (22) moves lever 1 (18) through pin (21). Lever 1 (18) rotates counterclockwise about pin (19) fixed to the axial plug.
- Pin (7), which is attached to feedback lever (13), is inserted into hole (23) of lever 1 (18). Therefore, feedback lever (13) rotates clockwise about pin (14) by the turning of lever 1 (18) and moves spool (2) to the right.
- When spool (2) moves, own pump delivery pressure  $P_3$  acts on the large chamber in servo piston (15) through spool (2). Although own pump delivery pressure  $P_3$  acts on the small chamber, servo piston (15) moves to the right due to the difference in pressure receiving area.
- As the pump displacement angle reduces according to the movement of servo piston (15), pump delivery flow rate decreases.
- When servo piston (15) moves, feedback lever (13) moves through pin (14). As neither pilot piston (22) nor lever 1 (18) moves, feedback lever (13) rotates counterclockwise about pin (7) and moves spool (2) to the left. When the notches on sleeve (3) and spool (2) are closed completely, own pump delivery pressure  $P_3$  does not act on the large chamber in servo piston (15) and servo piston (15) stops moving.

- With the above operation, pump delivery flow rate decreases according to increasing amount of flow rate control pressure  $P_i$ .

 **NOTE:** Refer to the pilot circuit in Hydraulic System group/ SYSTEM.

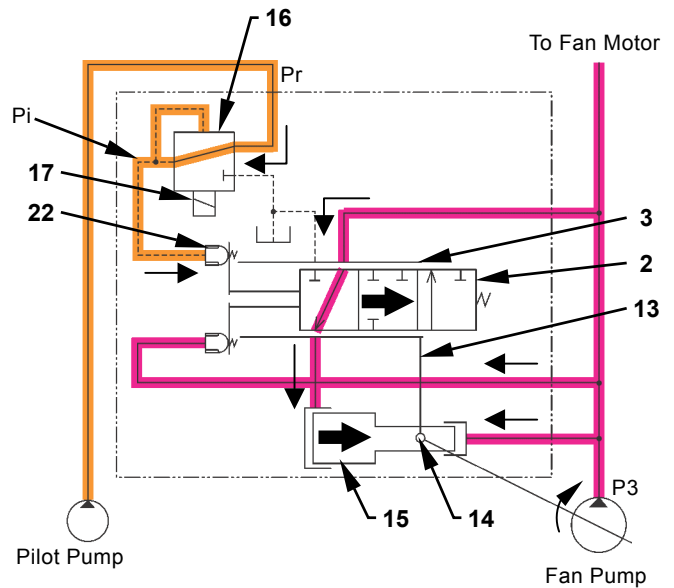
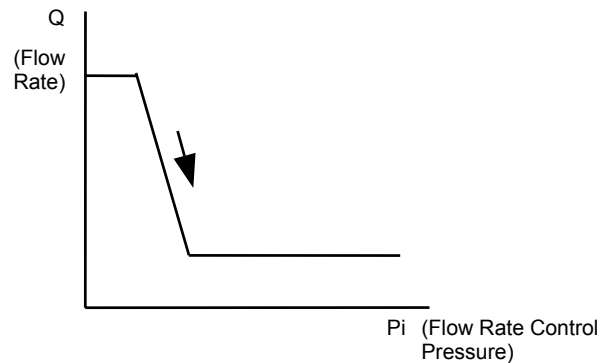

T1J1-03-01-022

# COMPONENT OPERATION / Pump Device

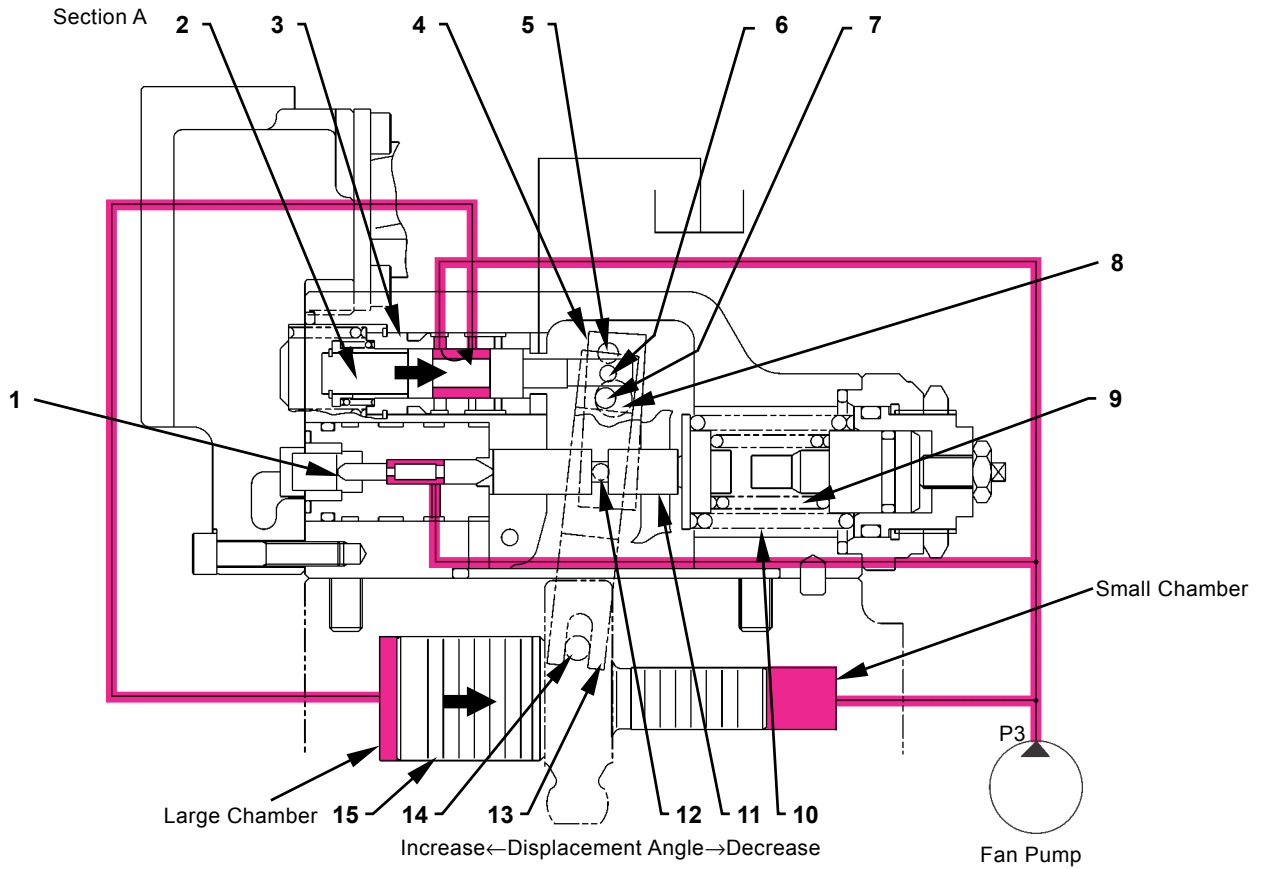

T1J1-03-01-030

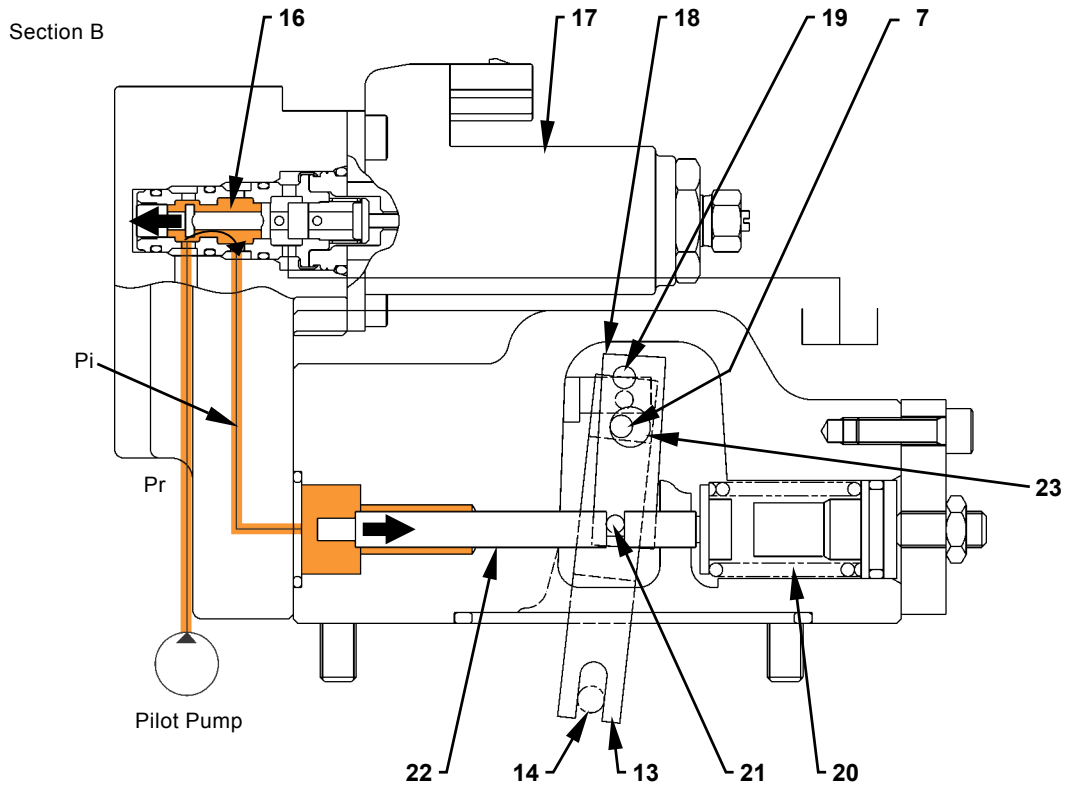

T1J1-03-01-019

**COMPONENT OPERATION / Pump Device**

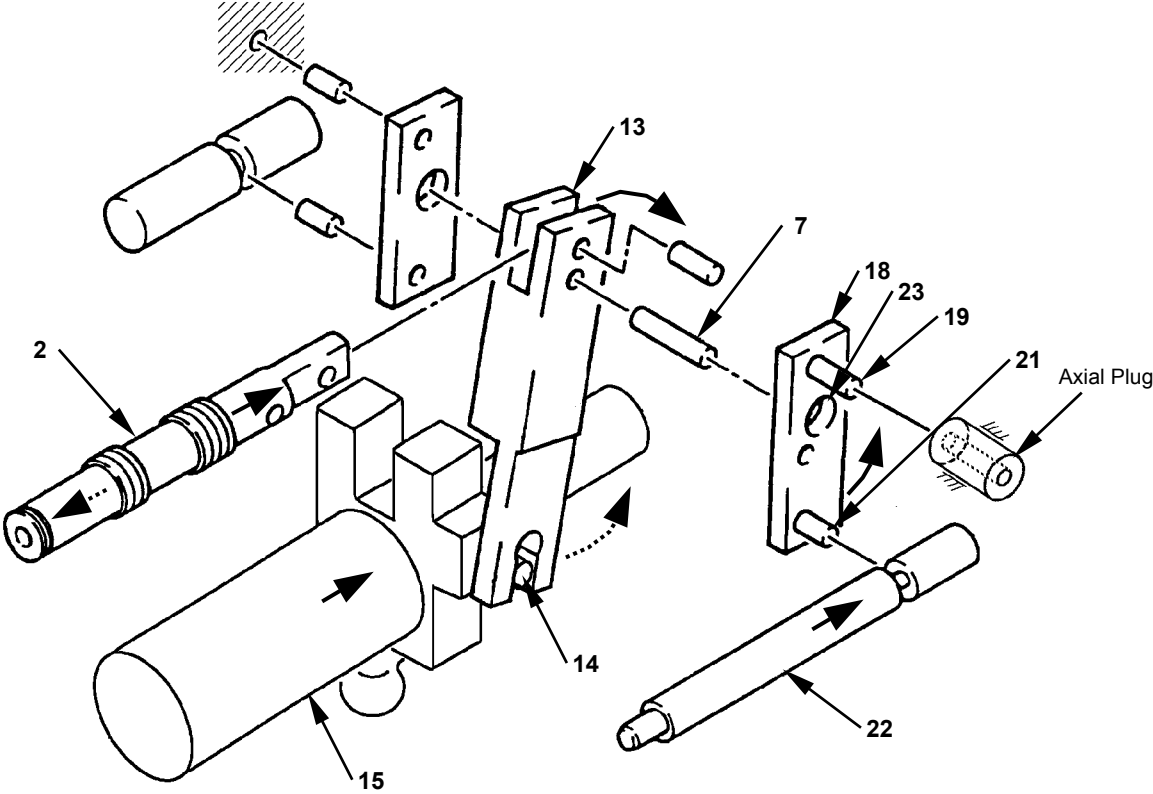

T1J1-03-01-007

## COMPONENT OPERATION / Pump Device

---

(Blank)



## COMPONENT OPERATION / Pump Device

- Increasing Flow Rate (Regulator Operation with Flow Rate Control Pressure Decreasing)

- When fan pump control solenoid valve (17) is activated, flow rate control pressure  $P_i$  in proportion to the movement of fan pump control solenoid valve (17) is routed to pilot piston (22) through spool (16). When pilot pressure  $P_i$  decreases, pilot piston (22) moves to the left until pilot piston (22) balances with spring (20).
- Pilot piston (22) moves lever 1 (18) through pin (21). Lever 1 (18) rotates clockwise about pin (19) fixed to the axial plug.
- Pin (7), which is attached to feedback lever (13), is inserted into hole (23) of lever 1 (18). Therefore, feedback lever (13) rotates counterclockwise about pin (14) by the turning of lever 1 (18) and moves spool (2) to the left.
- When spool (2) moves, the large chamber in servo piston (15) is connected to the hydraulic oil tank through spool (2). As own pump delivery pressure  $P_3$  acts on the small chamber, servo piston (15) moves to the left.
- As the pump displacement angle increases according to the movement of servo piston (15), pump delivery flow rate increases.
- When servo piston (15) moves, feedback lever (13) moves through pin (14). As neither pilot piston (22) nor lever 1 (18) moves, feedback lever (13) rotates clockwise about pin (7) and moves spool (2) to the right. When the notches on sleeve (3) and spool (2) are closed completely, the large chamber in servo piston (15) is not connected and servo piston (15) stops moving.

- With the above operation, pump delivery flow rate decreases according to increasing amount of flow rate control pressure  $P_i$ .

 **NOTE:** Refer to the pilot circuit in Hydraulic System group / SYSTEM.

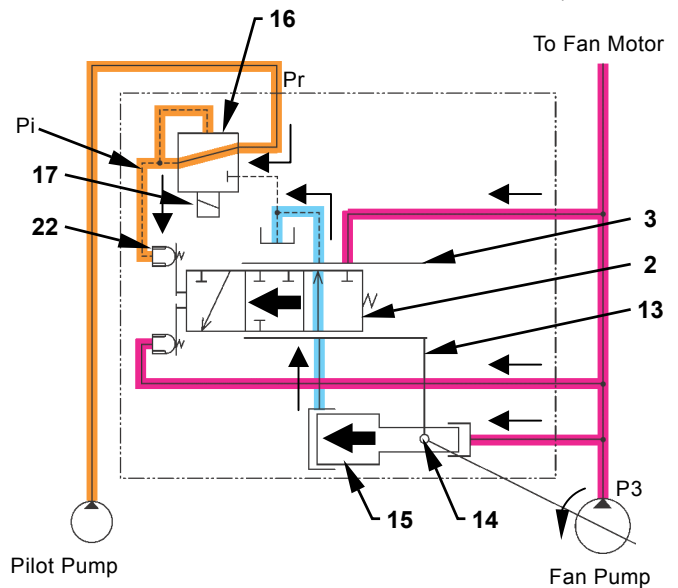
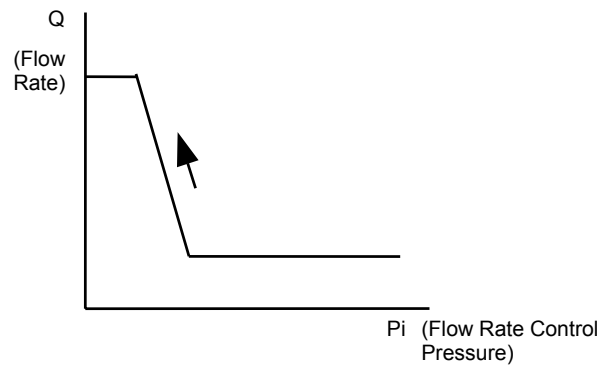

T1J1-03-01-023

# COMPONENT OPERATION / Pump Device

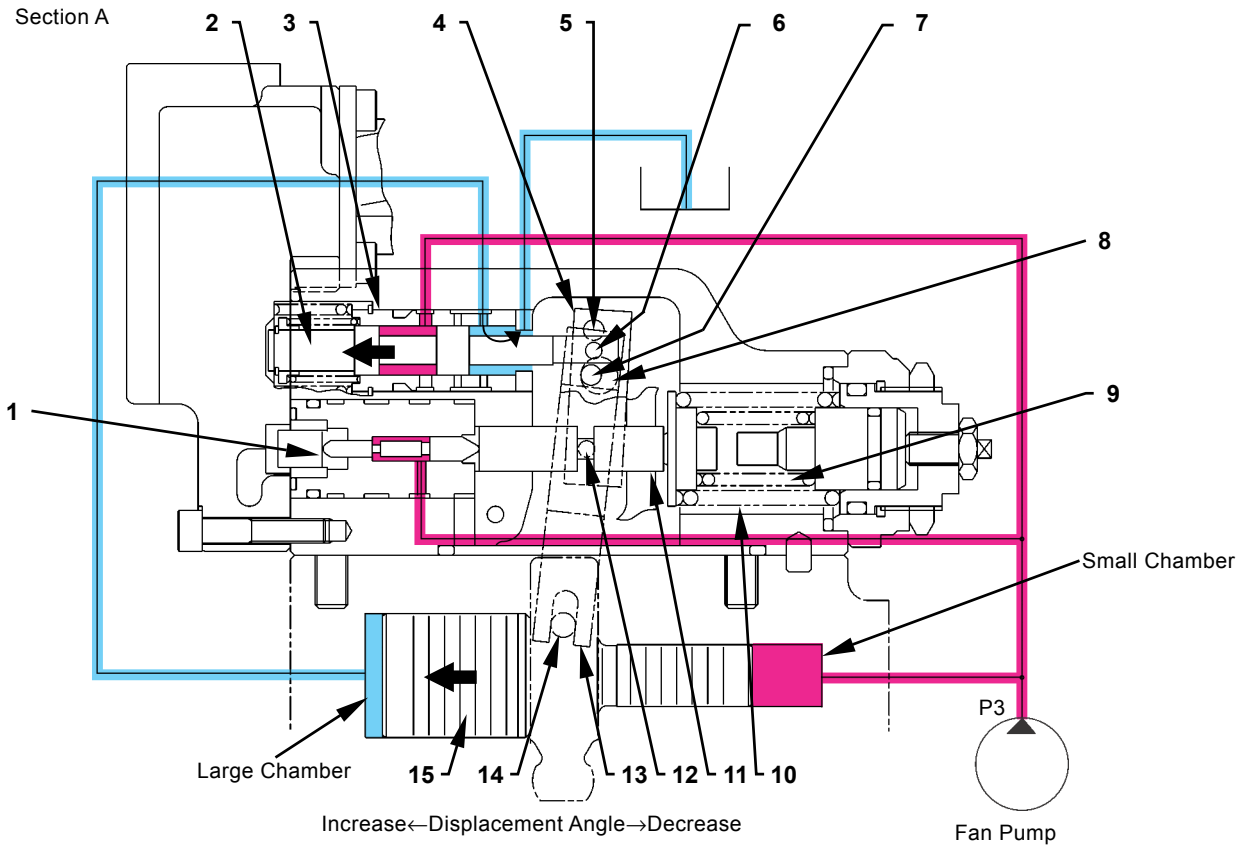

T1J1-03-01-016

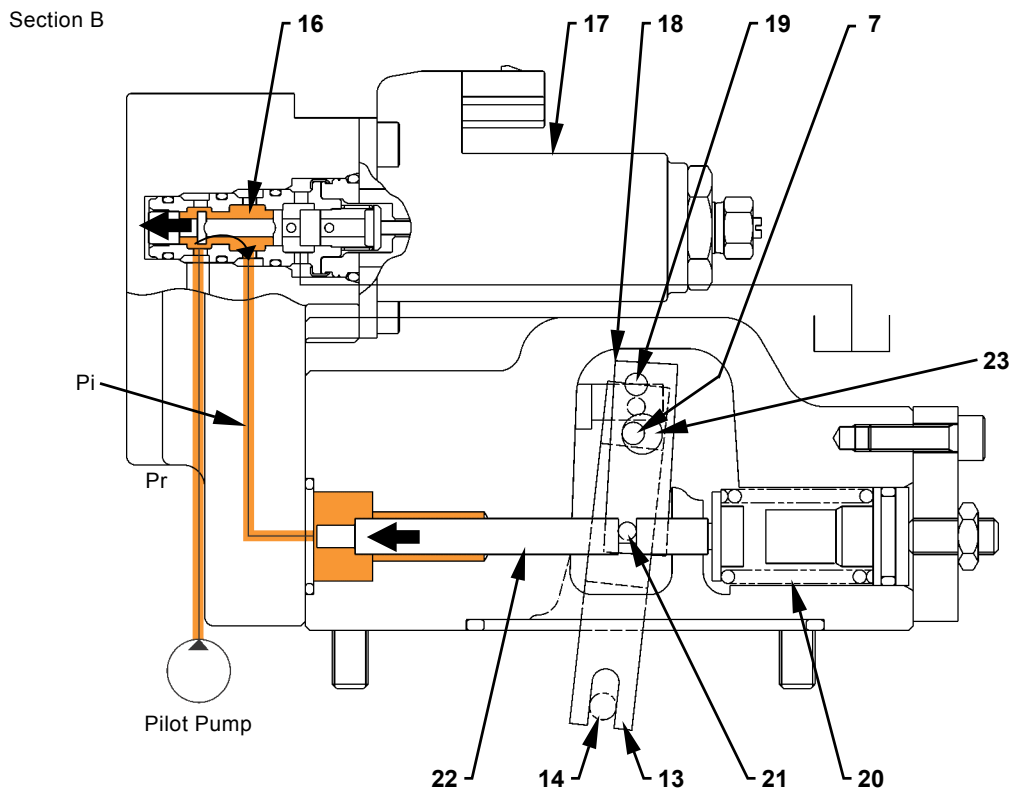

T1J1-03-01-031

**COMPONENT OPERATION / Pump Device**

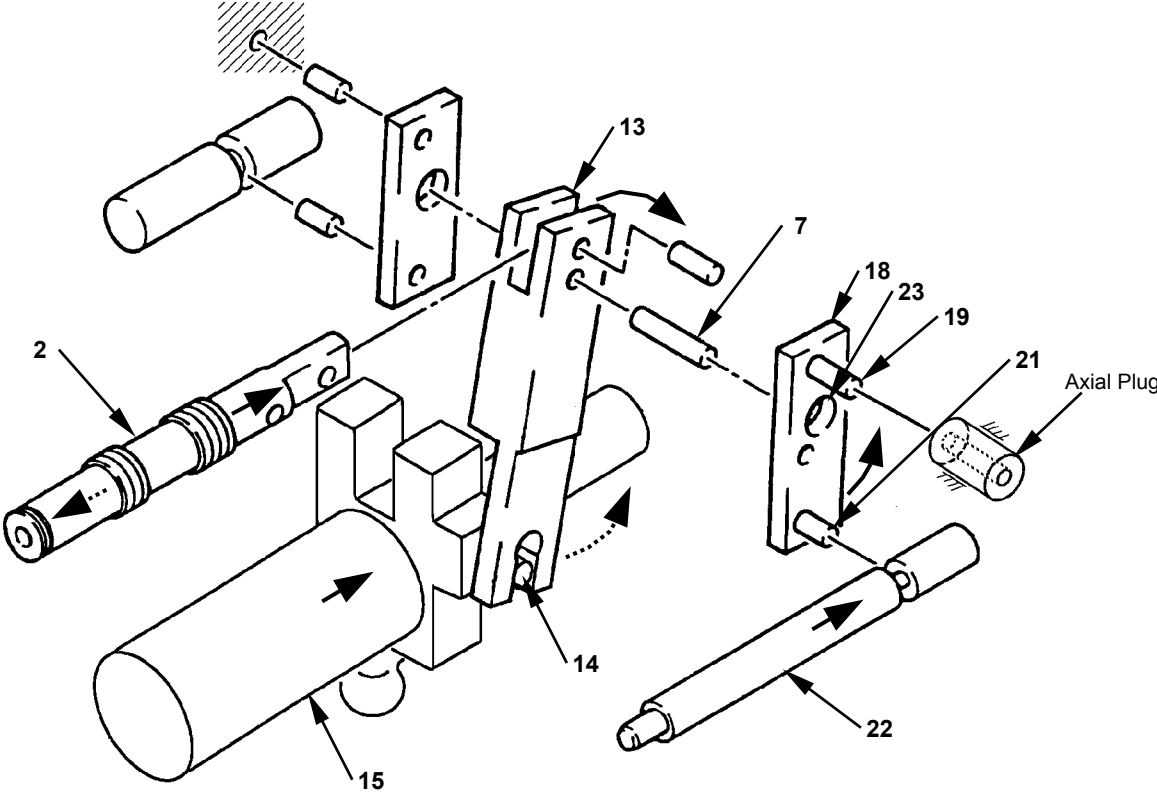

T1J1-03-01-007

## COMPONENT OPERATION / Pump Device

---

(Blank)

## COMPONENT OPERATION / Pump Device

### Control by Own Pump Delivery Pressure

 **NOTE:** This control is performed in case speed increases beyond the rated speed when starting.

- Decreasing Flow Rate

- When own pump delivery pressure P3 increases from C to D, compensating piston (1) moves compensating rod (11) to the right until compensating piston (1) balances with outer spring (10) and inner spring (9).
- Compensating rod (11) moves lever 2 (4) through pin (12). Lever 2 (4) rotates counterclockwise about pin (5) fixed to the housing.
- Pin (7), which is attached to feedback lever (13), is inserted into hole (8) of lever 2 (4). Therefore, feedback lever (13) rotates clockwise about pin (14) by the turning of lever 2 (4) and moves spool (2) to the right.
- When spool (2) moves, own pump delivery pressure P3 acts on the large chamber in servo piston (15) through spool (2). Although own pump delivery pressure P3 acts on the small chamber, servo piston (15) moves to the right due to the difference in pressure receiving area.
- The pump displacement angle reduces according to the movement of servo piston (15) and the pump delivery flow rate decreases.
- As own pump delivery pressure P3 acts on compensating piston (1), although piston (15) moves, compensating rod (11) and lever 2 (4) do not move.
- When servo piston (15) moves, feedback lever (13) moves through pin (14). As neither compensating rod (11) nor lever 2 (4) moves, feedback lever (13) rotates counterclockwise about pin (7) and move spool (2) to the left.

- The notches on spool (2) and sleeve (3) are closed completely and own pump delivery pressure P3 does not act on the large chamber in servo piston (15), so that the movement of servo piston (15) stops moving.
- With the above operation, pump delivery flow rate is decreased from A to B, and load of the pump is reduced.

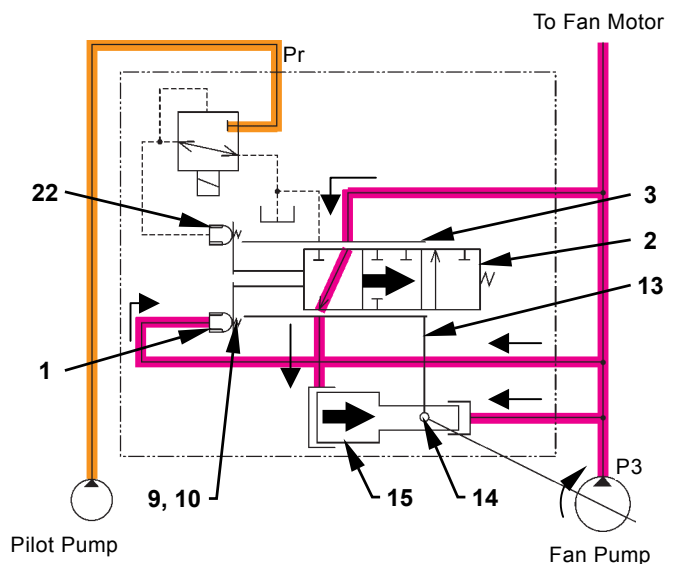
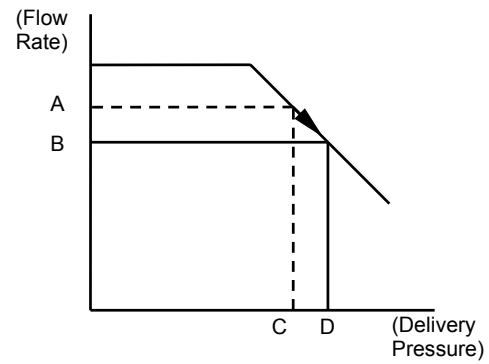

T1J1-03-01-015

# COMPONENT OPERATION / Pump Device

Section A

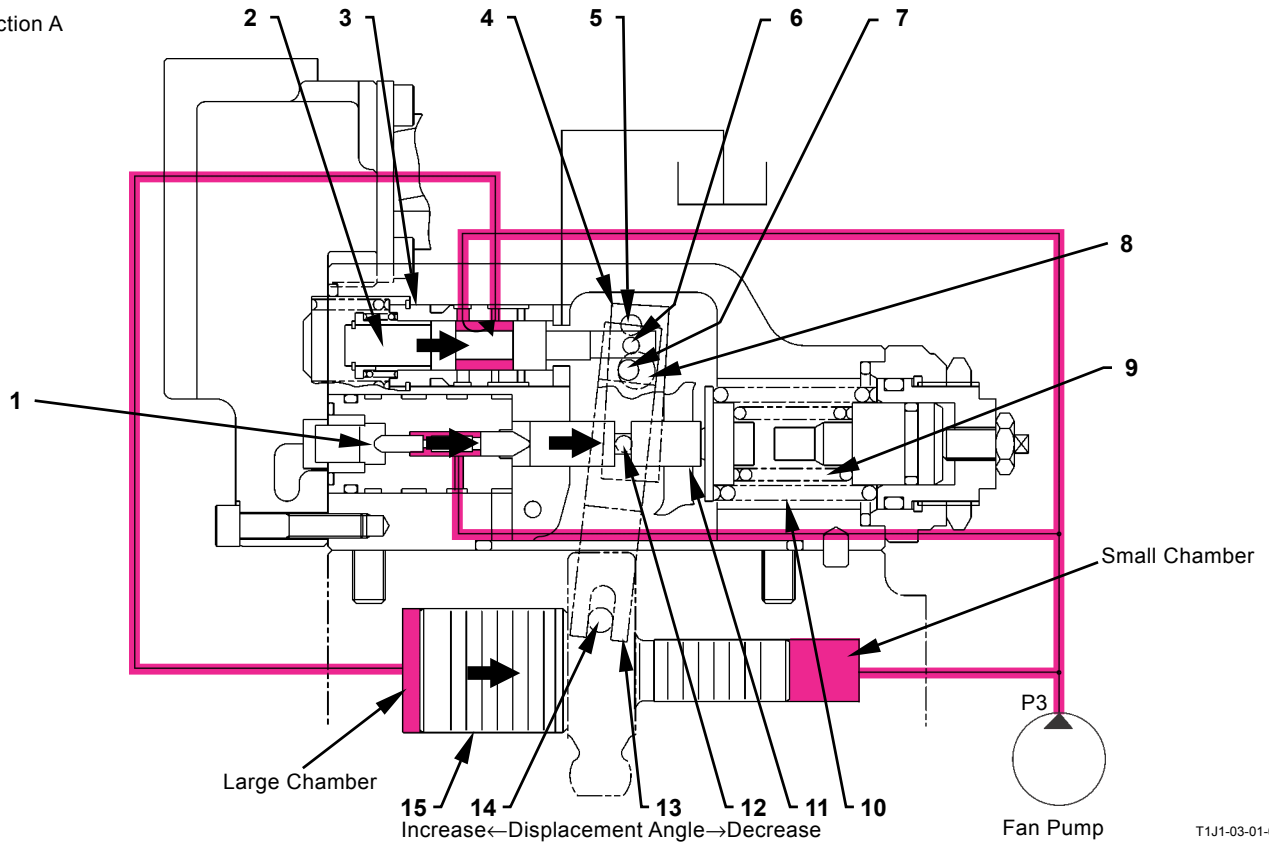

T1J1-03-01-014

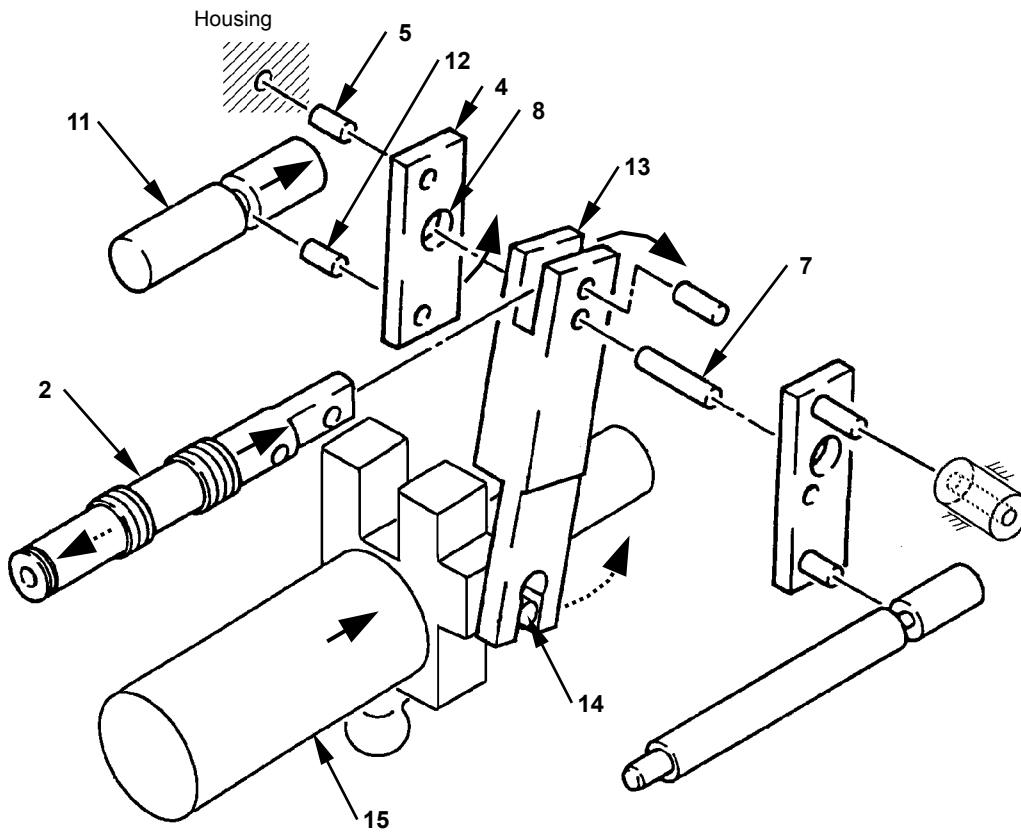

T1J1-03-01-007

## COMPONENT OPERATION / Pump Device

• Increasing Flow Rate

1. When own pump delivery pressure  $P_3$  decreases from D to C, compensating piston (1) and compensating rod (11) are returned to the left until compensating piston (1) balances with outer spring (10) and inner spring (9).
2. Compensating rod (11) moves lever 2 (4) through pin (12). Lever 2 (4) rotates clockwise about pin (5) fixed to the housing.
3. Pin (4), which is attached to feedback lever (7), is inserted into the hole of lever 2 (13). Therefore, feedback lever (13) rotates counterclockwise about pin (14) by the turning of lever 2 (4) to move spool (2) to the left.
4. When spool (2) moves, the large chamber in servo piston (15) is connected to the hydraulic oil tank through spool (2). As own pump delivery pressure  $P_3$  acts on the small chamber, servo piston (15) moves to the left.
5. The pump displacement angle increases according to the movement of servo piston (15) and pump delivery flow rate increases.
6. When servo piston (15) moves, feedback lever (13) moves through pin (14). As neither compensating rod (11) nor lever 2 (4) moves, feedback lever (13) rotates clockwise about pin (7) and moves spool (2) to the right. The notches on spool (2) and sleeve (3) are closed completely and the large chamber in servo piston (15) is not connected to the hydraulic oil tank, so that the movement of servo piston (15) stops moving.
7. With the above operation, pump delivery flow rate increases from B to A.

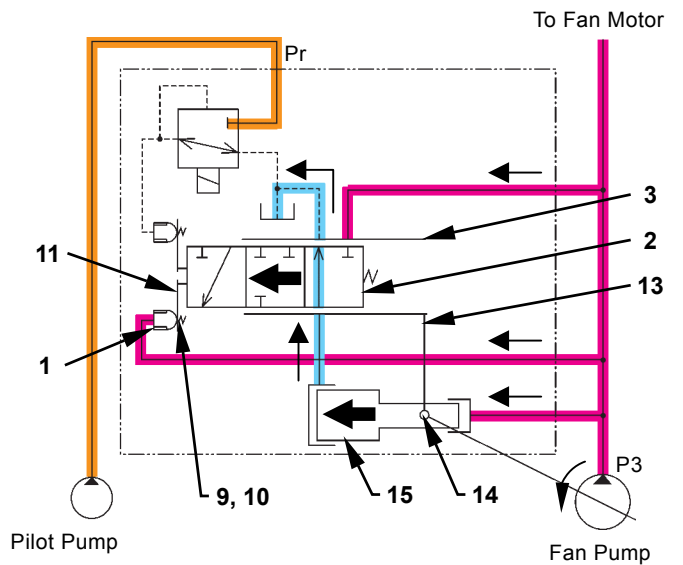
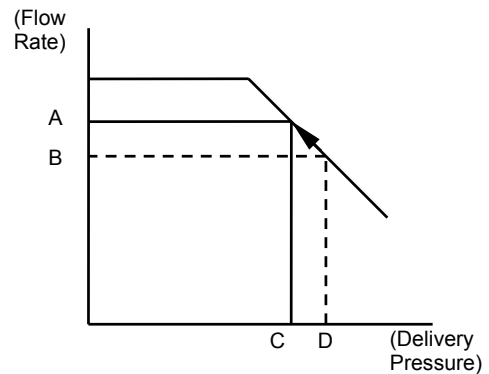

T1J1-03-01-017

# COMPONENT OPERATION / Pump Device

Section A

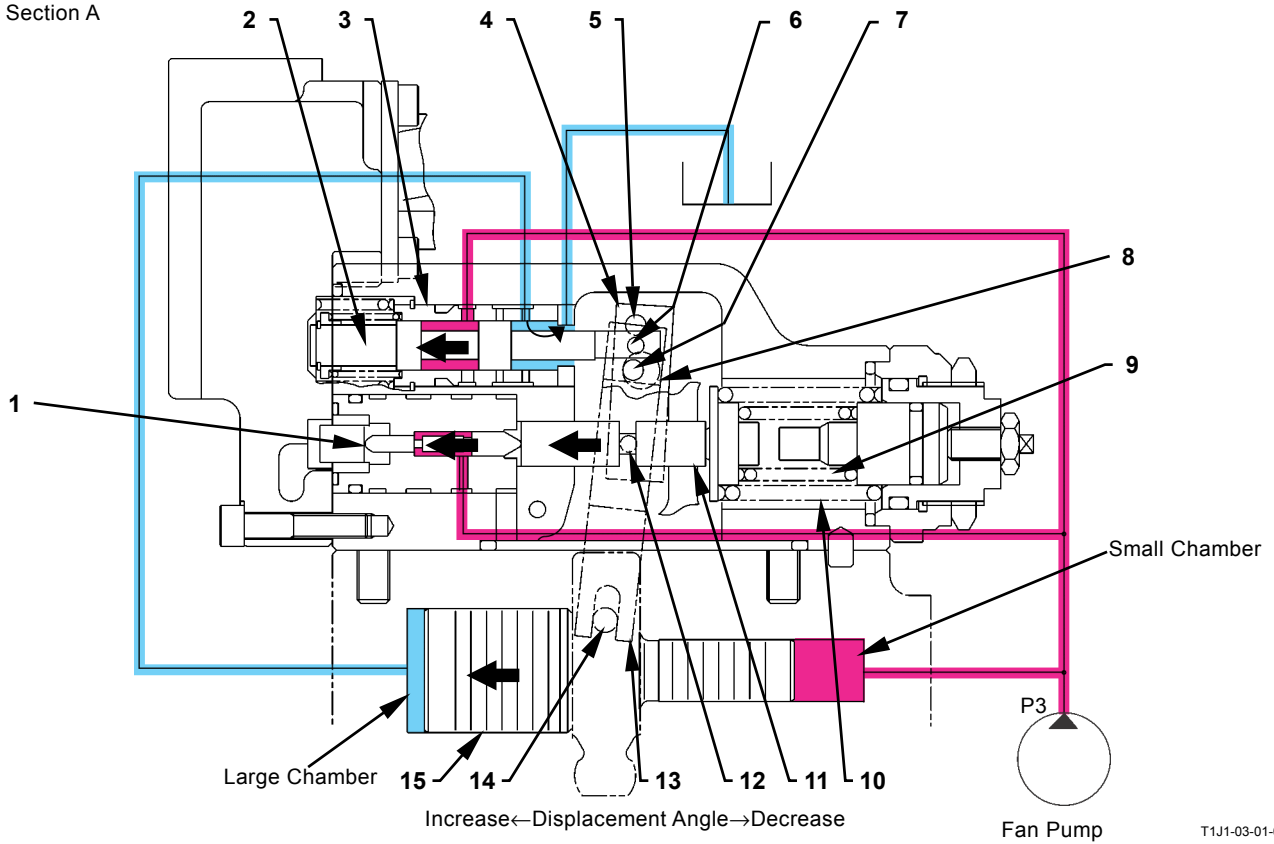

T1J1-03-01-016

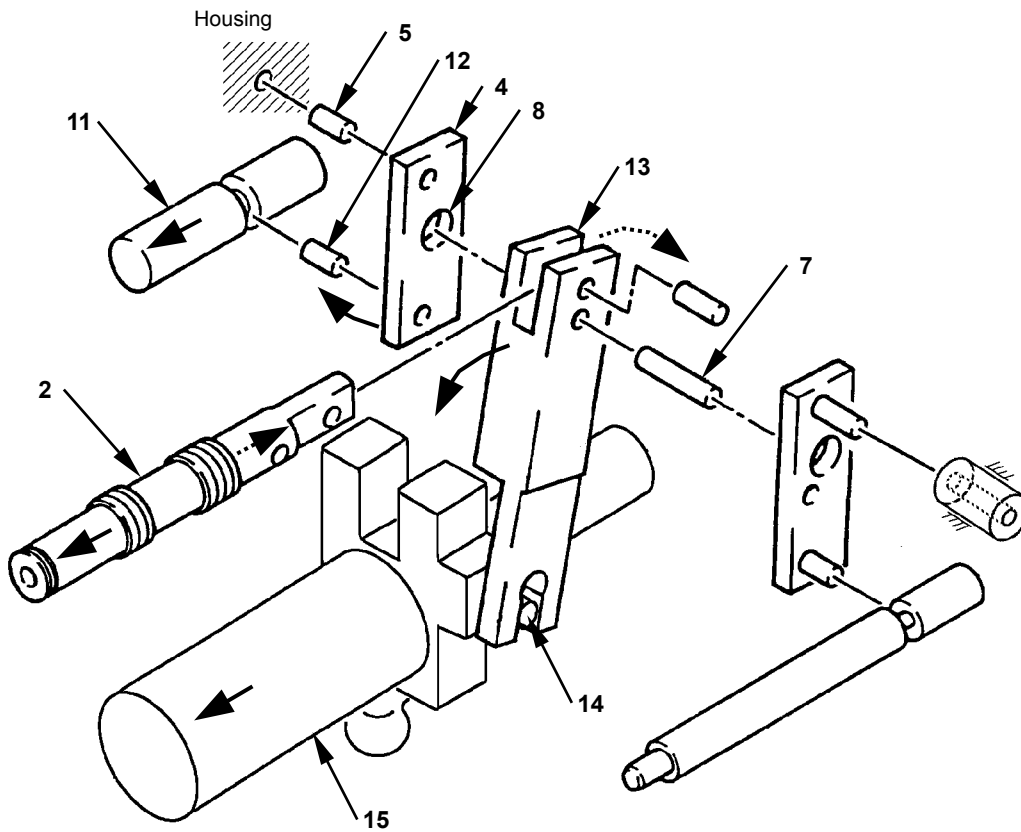

T1J1-03-01-007



# COMPONENT OPERATION / Pump Device

## PILOT PUMP

Drive gear (1) is driven by the engine through the transmission which in turn rotates driven gear (2) as they are meshed together.

- 1 - Drive Gear
- 2 - Driven Gear

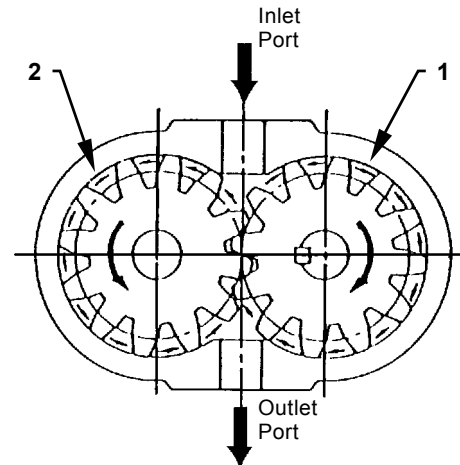

T137-02-03-005

## PUMP DELIVERY PRESSURE SENSOR

This sensor detects pump delivery pressures, which are used in order to control various operations. When oil pressure is applied onto diaphragm (6), diaphragm (6) is deformed. The deformation of diaphragm (6) is detected as the electrical signals.

- 3 - Ground
- 4 - Output
- 5 - Power Source (5V)
- 6 - Pressure Receiving Area (Diaphragm)

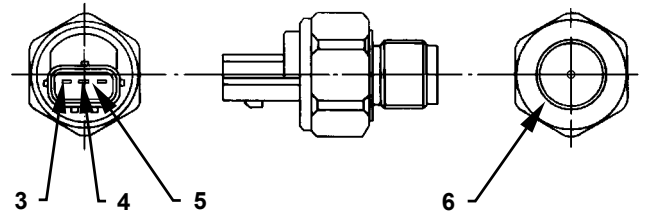

T157-02-03-010

## PUMP REGULATOR PRESSURE (FLOW RATE CONTROL PRESSURE) SENSOR

This sensor detects pump control pressures, which are used in order to control various operations. When oil pressure is applied onto diaphragm (7), diaphragm (7) is deformed. The deformation of diaphragm (7) is detected as the electrical signals.

- 7 - Pressure Receiving Area (Diaphragm)
- 8 - Ground
- 9 - Output
- 10 - Power Source (5V)

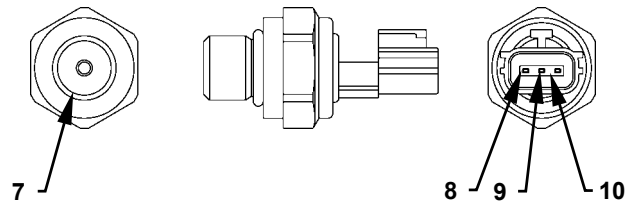

T1J1-03-01-029

## COMPONENT OPERATION / Swing Device

---

### OUTLINE

The swing device consists of the valve unit, the swing motor and the swing reduction gear.

The valve unit prevents the cavitation and overloads in the swing circuit.

The swing motor is a swash plate type axial plunger motor (with built-in swing parking brake), which is driven by pressure oil from the pump and is provided with the swing reduction gear.

The swing reduction gear turns the swing motor with large torque at a low speed and swings the upperstructure.

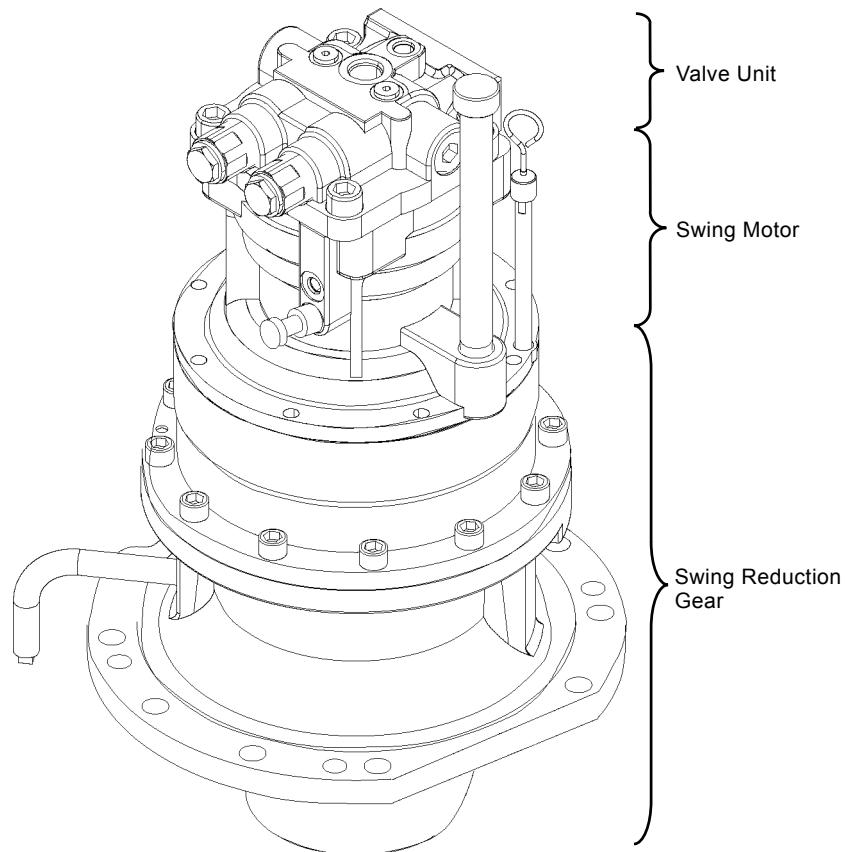

T16J-03-02-001

## COMPONENT OPERATION / Swing Device

### SWING REDUCTION GEAR

The swing reduction gear is a two-stage planetary gear type.

Ring gear (8) is provided on inside of the housing, is fixed to the upperstructure with the bolt, and does not rotate.

Shaft (6) in the swing motor drives first stage sun gear (5).

Then, rotary power is transmitted to second stage sun gear (3) via first stage planetary gear (7) and first stage carrier (4). Second stage sun gear (3) rotates shaft (1) via second stage planetary gear (9) and second stage carrier (2).

As shaft (1) meshes with the internal gear of swing bearing fixed to the undercarriage, the upperstructure is rotated.

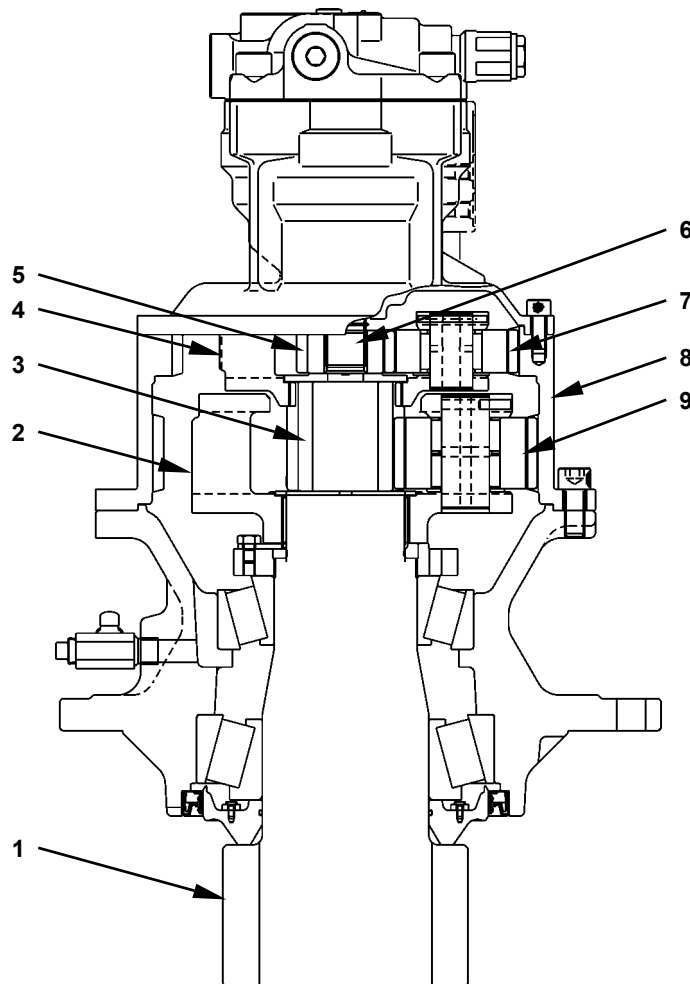

- |                           |                          |                                |                                 |
|---------------------------|--------------------------|--------------------------------|---------------------------------|
| 1 - Shaft                 | 4 - First Stage Carrier  | 6 - Shaft in Swing Motor       | 8 - Ring Gear                   |
| 2 - Second Stage Carrier  | 5 - First Stage Sun Gear | 7 - First Stage Planetary Gear | 9 - Second Stage Planetary Gear |
| 3 - Second Stage Sun Gear |                          |                                |                                 |

T1J7-03-02-001

## COMPONENT OPERATION / Swing Device

### SWING MOTOR

The swing motor consists of swash plate (1), rotor (4), plunger (10), valve plate (5), housing (3) and swing parking brake (springs (6), brake piston (7), plate (8), friction plate (9)).

Shaft (12) is splined to rotor (4) into which plunger (10) is inserted.

When pressure oil is supplied from the pump, plunger (10) is pushed. Shoe (2) at the top of plunger (10) slides over swash plate (1) so that rotor (4) rotates.

The top of shaft (12) is splined to the first stage sun gear of swing reduction gear. Therefore, the rotation of shaft (12) is transmitted to the swing reduction gear.

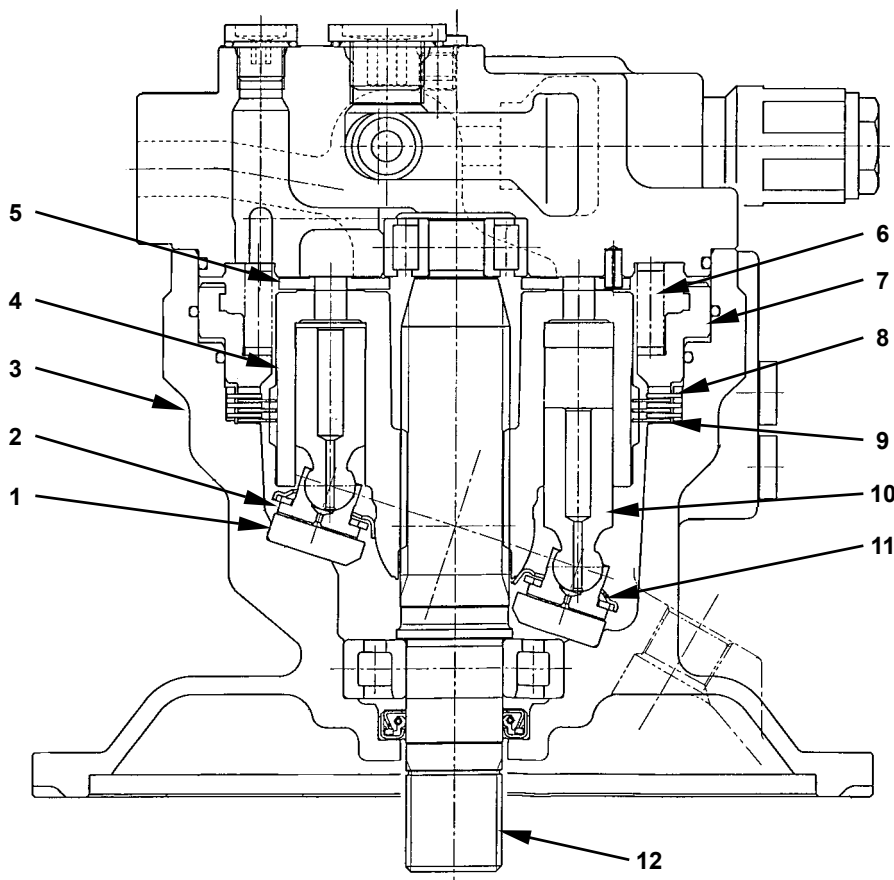

T178-03-02-002

- |                 |                 |                    |               |
|-----------------|-----------------|--------------------|---------------|
| 1 - Swash plate | 4 - Rotor       | 7 - Brake Piston   | 10 - Plunger  |
| 2 - Shoe        | 5 - Valve Plate | 8 - Plate          | 11 - Retainer |
| 3 - Housing     | 6 - Spring      | 9 - Friction Plate | 12 - Shaft    |

## COMPONENT OPERATION / Swing Device

---

### SWING PARKING BRAKE

The swing parking brake is a wet type multiplate disc brake and a negative mechanism that releases the brake when brake release pressure acts in brake piston chamber (8).

The brake release pressure is supplied from the pilot pump only when either swing or front attachment is operated.

In other cases (including engine stopping), the brake release pressure returns to the hydraulic oil tank, so that the brake is applied automatically by spring (4).

#### When Brake is Applied

1. When the swing or front attachment control lever is returned to neutral, the swing parking brake release spool in signal control valve is returned to neutral and pilot pressure to port SH disappears.
2. Check valve (7) is closed and the brake release pressure through orifice (6) is released to the swing motor housing.
3. As a result, the force of spring (4) acts on plate (2), which is engaged with the external circumference of rotor (1), and on friction plate (3), which is engaged with the inside of housing (9) through brake piston (5). Thus, the external circumference of rotor (1) is secured with friction force.

When the engine stops, the brake is applied automatically as pressure is not applied to port SH.

#### When Brake is Released

1. When the swing or front attachment control lever is operated, the swing parking brake release spool in signal control valve is shifted. Then, pilot pressure from the pilot pump is applied to port SH.
2. Pilot pressure to port SH pushes to open check valve (7), and acts in brake piston chamber (8).
3. As a result, as brake piston (5) is pushed upward, plate (2) and friction plate (3) are freed, so that the brake is released.

## COMPONENT OPERATION / Swing Device

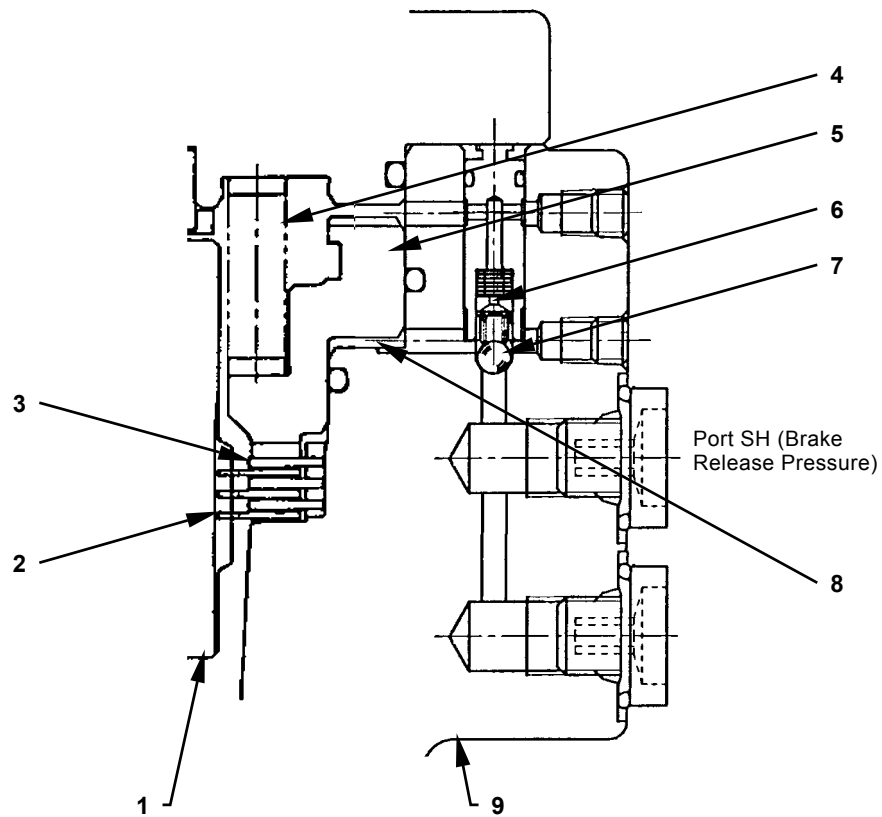

T178-03-02-003

1 - Rotor  
2 - Plate  
3 - Friction Plate

4 - Spring  
5 - Brake Piston

6 - Orifice  
7 - Check Valve

8 - Brake Piston Chamber  
9 - Housing

## COMPONENT OPERATION / Swing Device

### VALVE UNIT

The valve unit consists of make-up valve and relief valve.

The make-up valve prevents cavitation in the circuit and the relief valve prevents surge pressure and overloads in the circuit.

#### Make-Up Valve

During swing stopping operation, the swing motor is driven by the inertial force of swing frame. The swing motor is turned forcibly in excess of oil pressure from the pump, so that cavitation may be generated in the motor.

In order to avoid this cavitation, when pressure in the swing circuit becomes lower than that in the return circuit (port M), the poppet opens to draw hydraulic oil, and compensates the lack of oil feed.

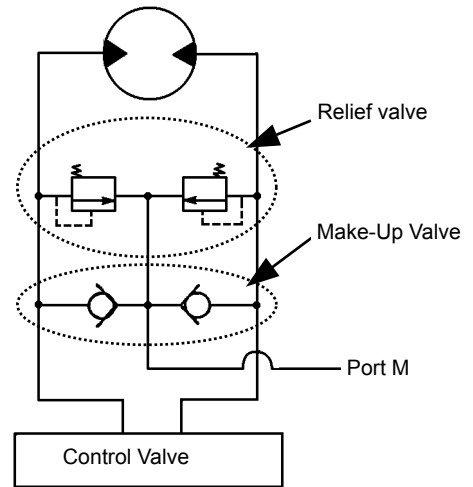

T1J1-03-02-001

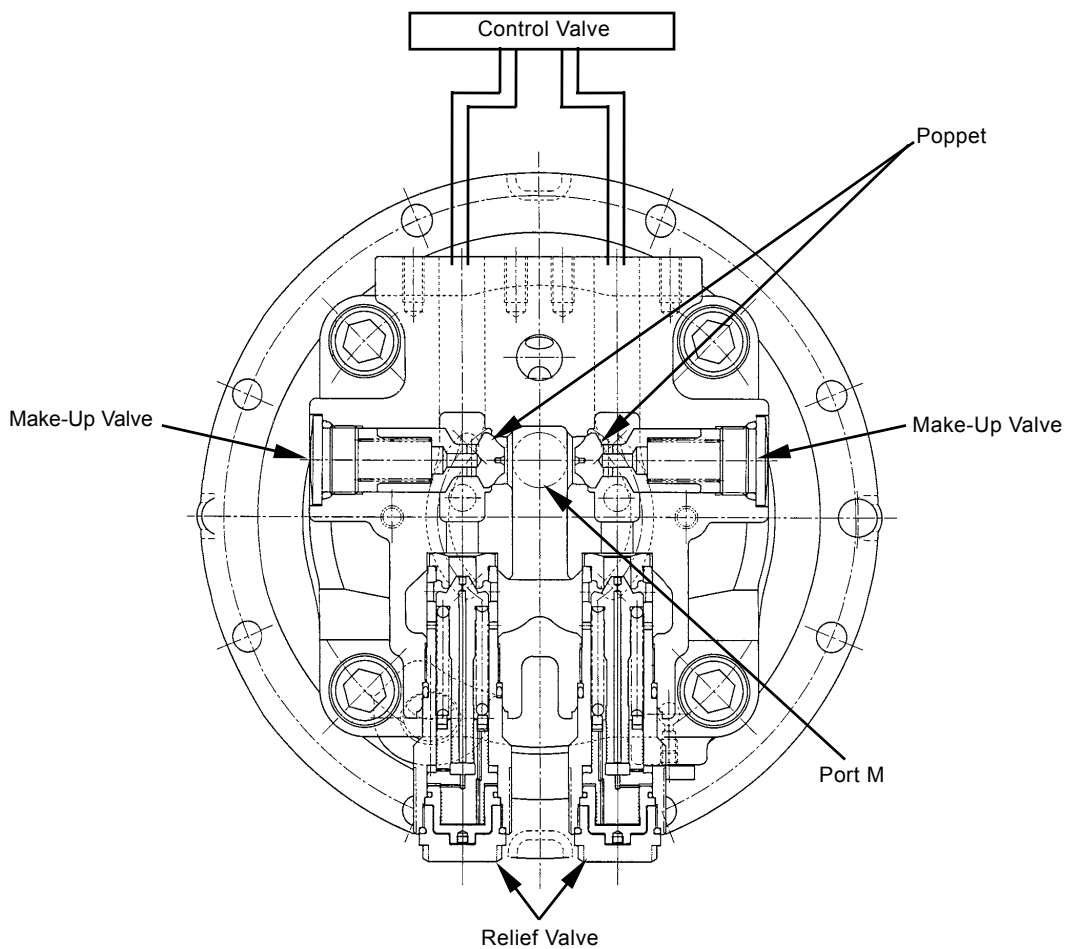

T178-03-02-004

## COMPONENT OPERATION / Swing Device

### Relief Valve

During starting or stopping swing operation, pressure in the swing circuit becomes high. The relief valve prevents the circuit pressure from rising higher than the set-pressure.

#### Low Pressure Relief Operation (Shockless Function):

1. Pressure at port HP (swing circuit) is routed into oil chamber C (9) through orifice (2) in poppet (1).
2. When pressure oil in chamber C (9) flows to oil chamber A (8) through passage A (4) and to oil chamber B (7) through passage B (5).
3. As the receiving area in oil chamber B (7) is larger than that in oil chamber A (8), piston (6) moves to the left.
4. As long as piston (6) keeps moving, a pressure difference is developed between the front and the rear of poppet (1). When this pressure difference is increased more than the spring (3) force, poppet (1) is unseated and pressure oil flows to port LP from port HP.
5. When piston (6) is moved to full stroke, the pressure difference between the front and the rear of poppet (1) disappears and poppet (1) is seated.

#### High Pressure Relief Operation (Overload Prevention):

1. After piston (6) is moved to full stroke, spring (3) is compressed and the circuit pressure becomes the relief set-pressure.
2. If pressure at port HP increases more than the spring (3) set-pressure, poppet (1) is unseated and pressure oil flows to port LP from port HP.
3. When pressure at port HP is reduced to the specified level, poppet (1) is seated by the spring (3) force.

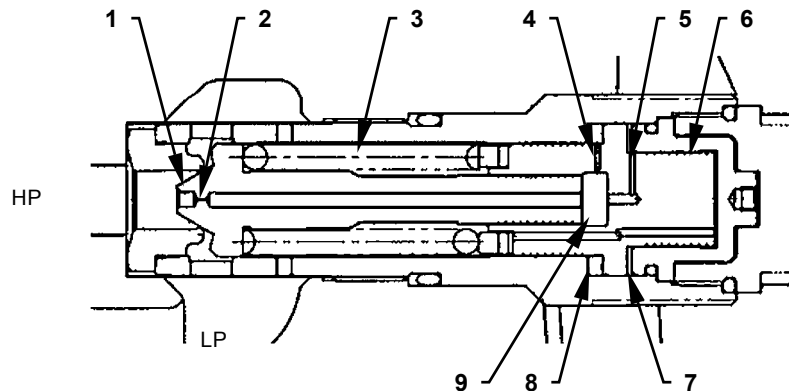

T178-03-02-005

- 1 - Poppet
- 2 - Orifice
- 3 - Spring

- 4 - Passage A
- 5 - Passage B

- 6 - Piston
- 7 - Oil Chamber B

- 8 - Oil Chamber A
- 9 - Oil Chamber C



## COMPONENT OPERATION / Swing Device

---

(Blank)

## COMPONENT OPERATION / Control Valve

### OUTLINE

The control valve controls the pressure, flow rate and flow direction in the hydraulic circuit. The main control valve consists of two rows of 4-spool section and 5-spool section.

The major parts are main relief valve, flow combiner valve and spools, and are operated by pilot oil pressure.

As for the spools, in the 4-spool section of control valve, right travel, bucket, boom 1 and arm 2 are arranged in that order as viewed from the machine front. In the 5-spool section, left travel, auxiliary, boom 2, arm 1 and swing are arranged in that order as viewed from the machine front.

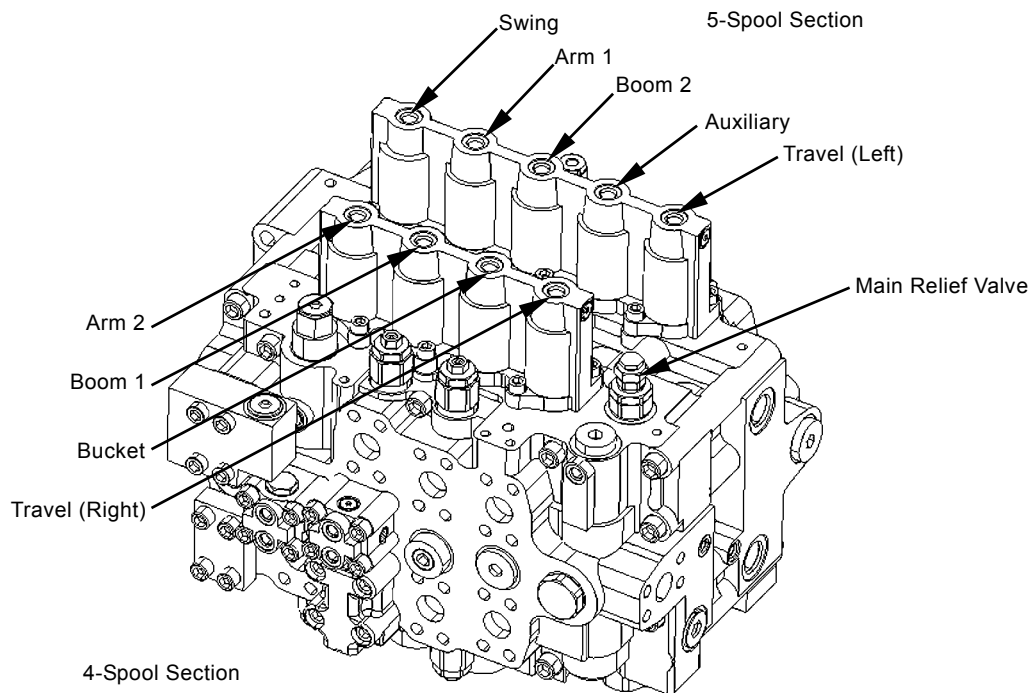

T1JB-03-03-024

# COMPONENT OPERATION / Control Valve

## Layout

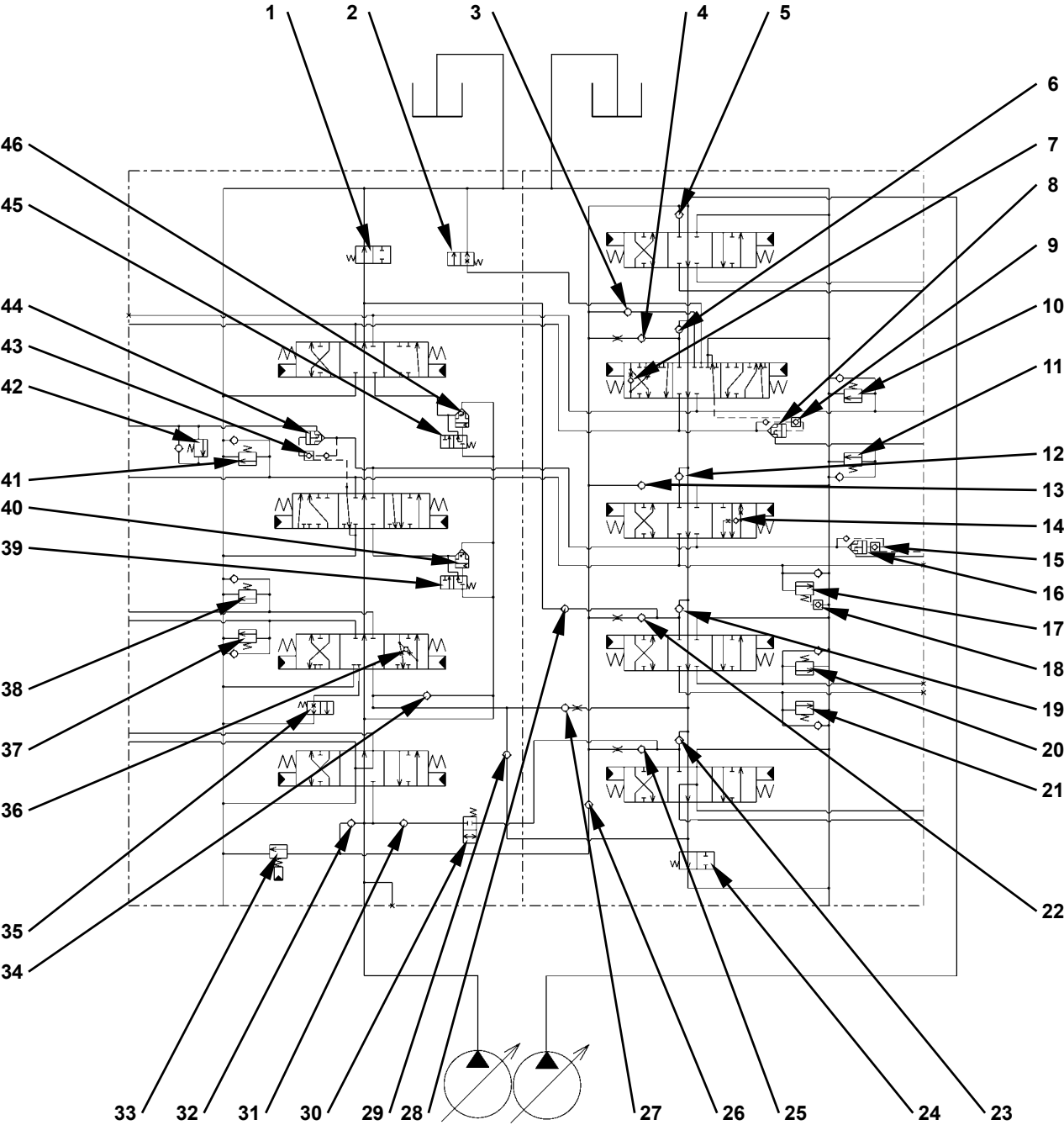

T1J7-03-03-003

# COMPONENT OPERATION / Control Valve

## 4-Spool Section

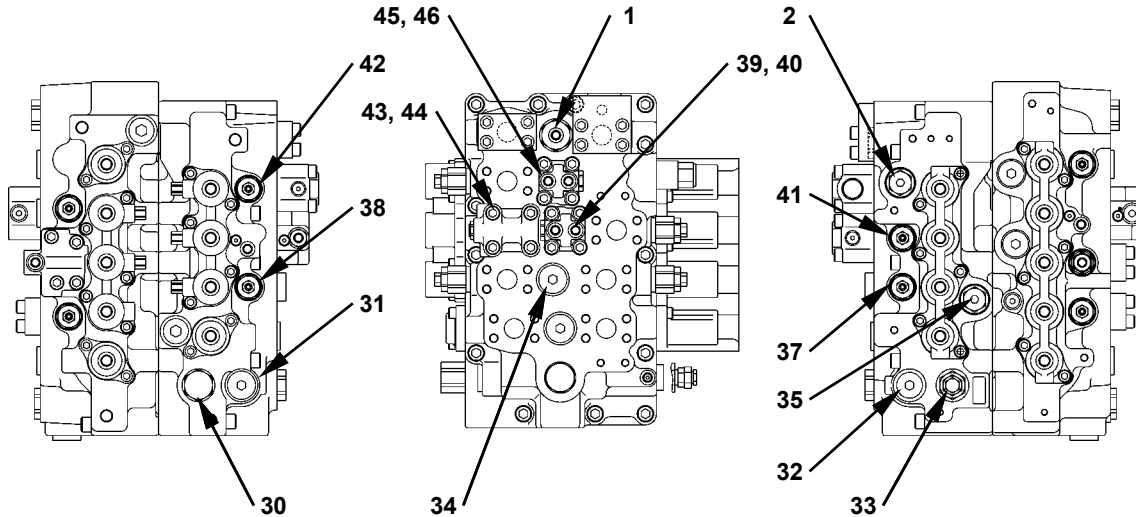

T1J7-03-03-001

- |   |  |  |  |
|---|--|--|--|
| 1 - Bypass Shut-Out Valve                             | 13 - Load Check Valve (Boom 2 Parallel Circuit)    | 25 - Load Check Valve (Left Travel Parallel Circuit)           | 37 - Overload Relief Valve (Bucket Roll-Out)     |
| 2 - Arm Regenerative Valve (Switch Valve)             | 14 - Boom Regenerative Valve                       | 26 - Check Valve (Main Relief Pressure Flow Combining Circuit) | 38 - Overload Relief Valve (Bucket Roll-In)      |
| 3 - Check Valve (Arm 1 Roll-Out Parallel Circuit)     | 15 - Boom Anti-Drift Valve (Switch Valve)          | 27 - Check Valve (Bucket Flow Combining Circuit)               | 39 - Boom Flow Rate Control Valve (Switch Valve) |
| 4 - Load Check Valve (Arm 1 Roll-In Parallel Circuit) | 16 - Boom Anti-Drift Valve (Check Valve)           | 28 - Check Valve (Auxiliary Flow Combining Circuit)            | 40 - Boom Flow Control Valve (Poppet Valve)      |
| 5 - Load Check Valve (Swing Tandem Circuit)           | 17 - Overload Relief Valve (Boom Mode)             | 29 - Check Valve (Bucket Flow Combining Circuit)               | 41 - Overload Relief Valve (Boom Lower)          |
| 6 - Load Check Valve (Arm 1 Tandem Circuit)           | 18 - Boom Overload Relief Control Valve            | 30 - Flow Combiner Valve                                       | 42 - Overload Relief Valve (Boom Raise)          |
| 7 - Arm Regenerative Valve (Check Valve)              | 19 - Load Check Valve (Auxiliary Tandem Circuit)   | 31 - Check Valve (Flow Combiner Valve Circuit)                 | 43 - Boom Anti-Drift Valve (Switch Valve)        |
| 8 - Arm Anti-Drift Valve (Check Valve)                | 20 - Overload Relief Valve (Auxiliary)             | 32 - Check Valve (Main Relief Pressure Flow Combining Circuit) | 44 - Boom Anti-Drift Valve (Check Valve)         |
| 9 - Arm Anti-Drift Valve (Switch Valve)               | 21 - Overload Relief Valve (Auxiliary)             | 33 - Main Relief Valve   | 45 - Arm Flow Rate Control Valve (Switch Valve)  |
| 10 - Overload Relief Valve (Arm Roll-Out)             | 22 - Load Check Valve (Auxiliary Parallel Circuit) | 34 - Load Check Valve (Bucket Parallel Circuit)                | 46 - Arm Flow Rate Control Valve (Poppet Valve)  |
| 11 - Overload Relief Valve (Arm Roll-In)              | 23 - Load Check Valve (Left Travel Tandem Circuit) | 35 - Bucket Regenerative Valve (Switch Valve)                  |  |
| 12 - Load Check Valve (Boom 2 Tandem Circuit)         | 24 - Bypass Shut-Out Valve                         | 36 - Bucket Regenerative Valve (Check Valve)                   |  |

# COMPONENT OPERATION / Control Valve

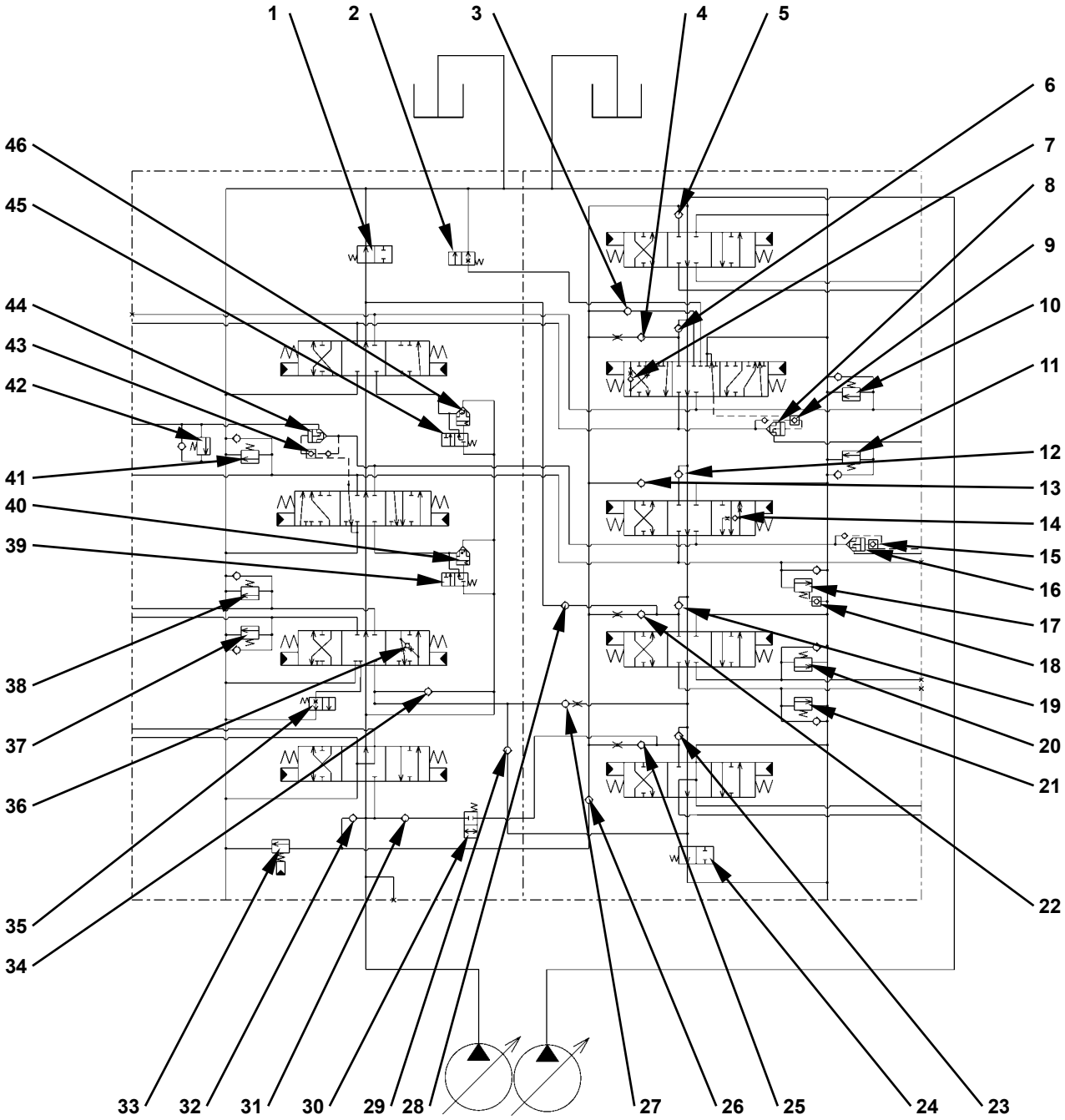

T1J7-03-03-003

## COMPONENT OPERATION / Control Valve

### 5-Spool Section

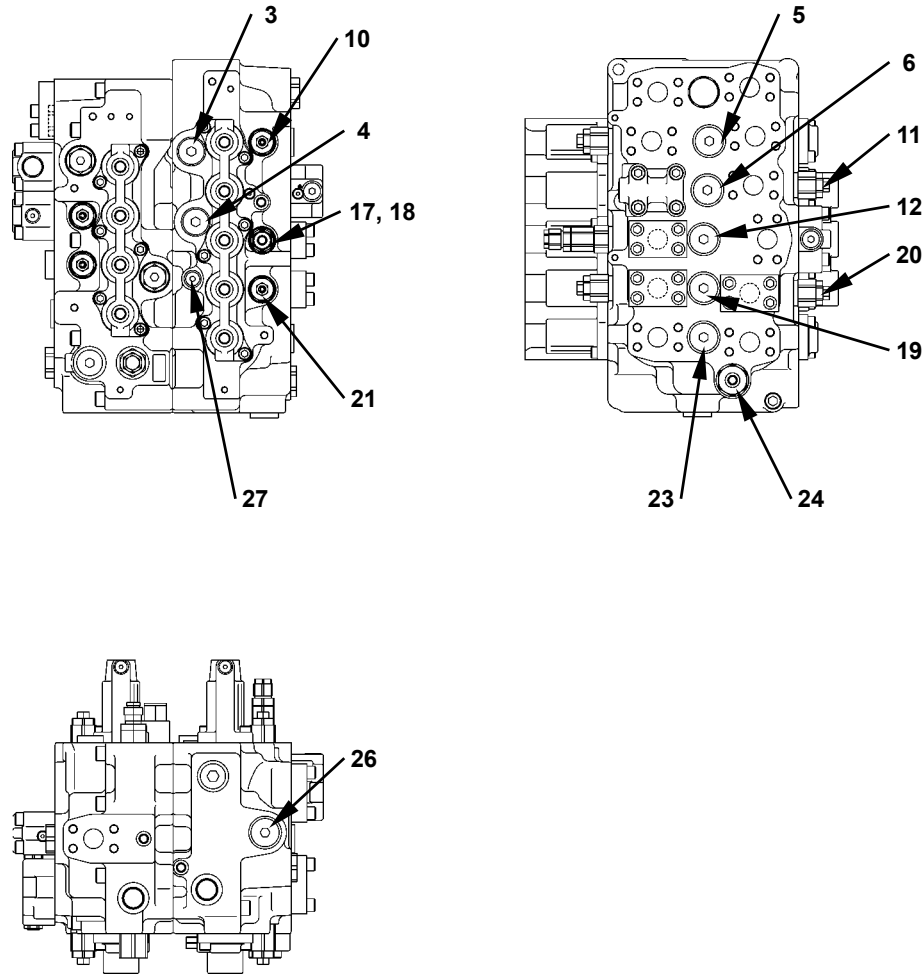

T1J7-03-03-002

- |   |  |  |  |
|---|--|--|--|
| 1 - Bypass Shut-Out Valve                             | 13 - Load Check Valve (Boom 2 Parallel Circuit)    | 25 - Load Check Valve (Left Travel Parallel Circuit)           | 37 - Overload Relief Valve (Bucket Roll-Out)     |
| 2 - Arm Regenerative Valve (Switch Valve)             | 14 - Boom Regenerative Valve                       | 26 - Check Valve (Main Relief Pressure Flow Combining Circuit) | 38 - Overload Relief Valve (Bucket Roll-In)      |
| 3 - Check Valve (Arm 1 Roll-Out Parallel Circuit)     | 15 - Boom Anti-Drift Valve (Switch Valve)          | 27 - Check Valve (Bucket Flow Combining Circuit)               | 39 - Boom Flow Rate Control Valve (Switch Valve) |
| 4 - Load Check Valve (Arm 1 Roll-In Parallel Circuit) | 16 - Boom Anti-Drift Valve (Check Valve)           | 28 - Check Valve (Auxiliary Flow Combining Circuit)            | 40 - Boom Flow Control Valve (Poppet Valve)      |
| 5 - Load Check Valve (Swing Tandem Circuit)           | 17 - Overload Relief Valve (Boom Mode)             | 29 - Check Valve (Bucket Flow Combining Circuit)               | 41 - Overload Relief Valve (Boom Lower)          |
| 6 - Load Check Valve (Arm 1 Tandem Circuit)           | 18 - Boom Overload Relief Control Valve            | 30 - Flow Combiner Valve                                       | 42 - Overload Relief Valve (Boom Raise)          |
| 7 - Arm Regenerative Valve (Check Valve)              | 19 - Load Check Valve (Auxiliary Tandem Circuit)   | 31 - Check Valve (Flow Combiner Valve Circuit)                 | 43 - Boom Anti-Drift Valve (Switch Valve)        |
| 8 - Arm Anti-Drift Valve (Check Valve)                | 20 - Overload Relief Valve (Auxiliary)             | 32 - Check Valve (Main Relief Pressure Flow Combining Circuit) | 44 - Boom Anti-Drift Valve (Check Valve)         |
| 9 - Arm Anti-Drift Valve (Switch Valve)               | 21 - Overload Relief Valve (Auxiliary)             | 33 - Main Relief Valve   | 45 - Arm Flow Rate Control Valve (Switch Valve)  |
| 10 - Overload Relief Valve (Arm Roll-Out)             | 22 - Load Check Valve (Auxiliary Parallel Circuit) | 34 - Load Check Valve (Bucket Parallel Circuit)                | 46 - Arm Flow Rate Control Valve (Poppet Valve)  |
| 11 - Overload Relief Valve (Arm Roll-In)              | 23 - Load Check Valve (Left Travel Tandem Circuit) | 35 - Bucket Regenerative Valve (Switch Valve)                  |  |
| 12 - Load Check Valve (Boom 2 Tandem Circuit)         | 24 - Bypass Shut-Out Valve                         | 36 - Bucket Regenerative Valve (Check Valve)                   |  |

# COMPONENT OPERATION / Control Valve

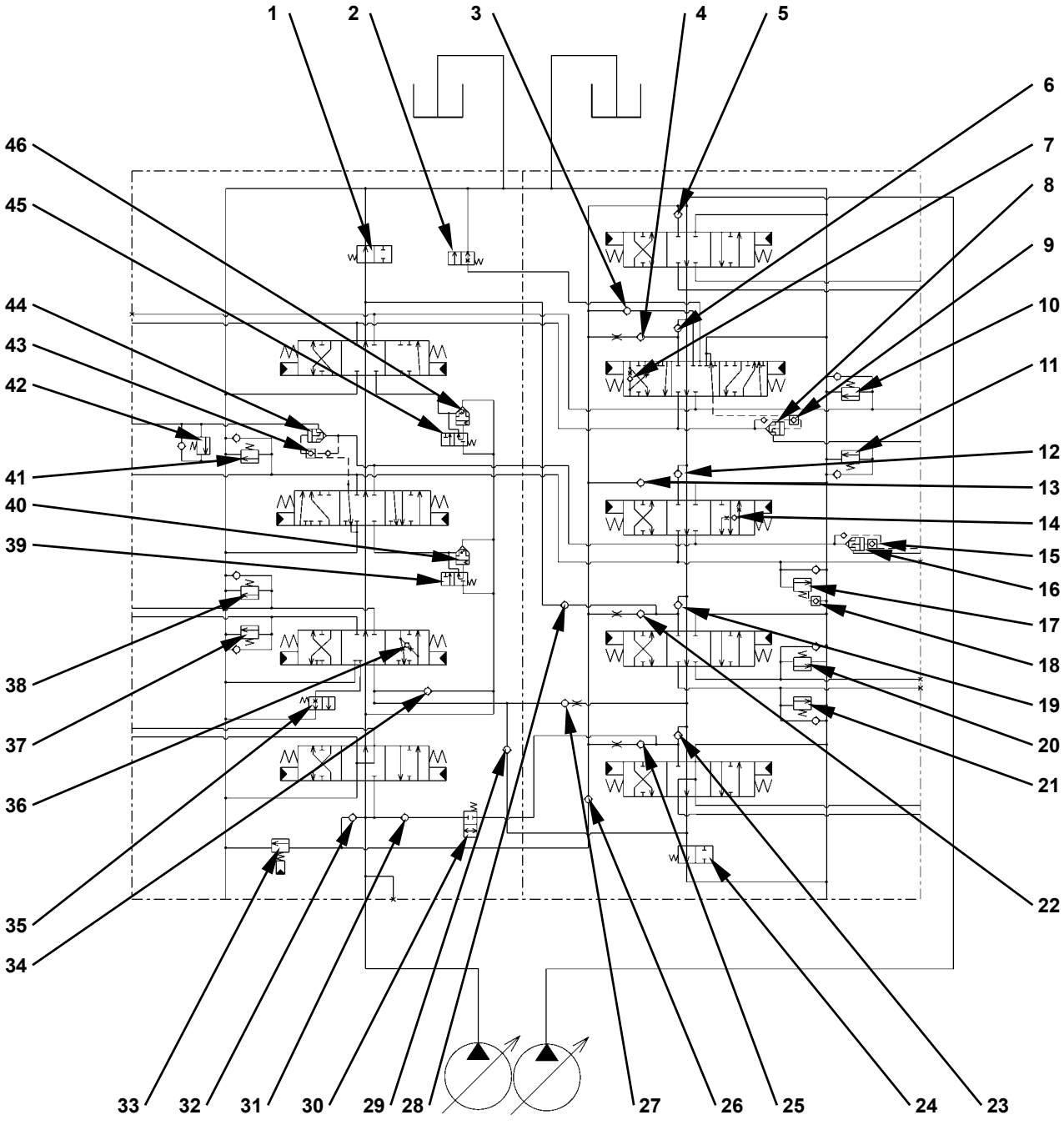

T1J7-03-03-003

# COMPONENT OPERATION / Control Valve

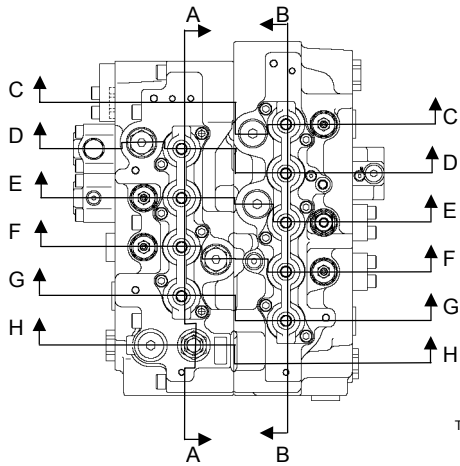

T450-03-03-001

Cross Section A-A

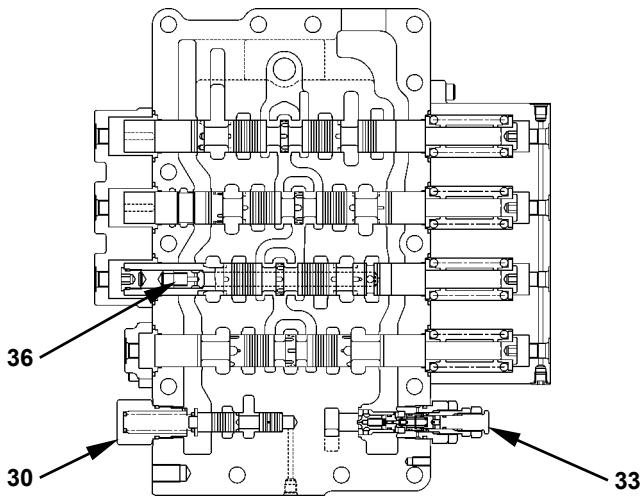

T1JB-03-03-002

Cross Section B-B

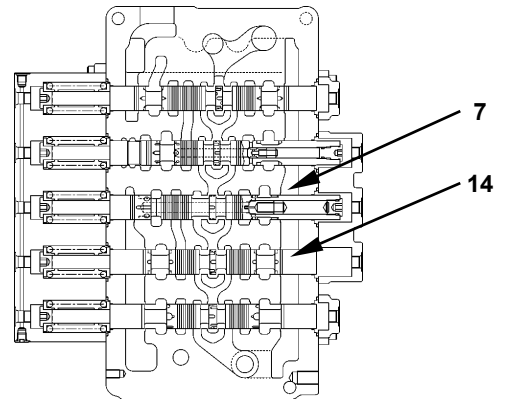

T1JB-03-03-001

- |   |  |  |  |
|---|--|--|--|
| 1 - Bypass Shut-Out Valve                             | 13 - Load Check Valve (Boom 2 Parallel Circuit)    | 25 - Load Check Valve (Left Travel Parallel Circuit)           | 37 - Overload Relief Valve (Bucket Roll-Out)     |
| 2 - Arm Regenerative Valve (Switch Valve)             | 14 - Boom Regenerative Valve                       | 26 - Check Valve (Main Relief Pressure Flow Combining Circuit) | 38 - Overload Relief Valve (Bucket Roll-In)      |
| 3 - Check Valve (Arm 1 Roll-Out Parallel Circuit)     | 15 - Boom Anti-Drift Valve (Switch Valve)          | 27 - Check Valve (Bucket Flow Combining Circuit)               | 39 - Boom Flow Rate Control Valve (Switch Valve) |
| 4 - Load Check Valve (Arm 1 Roll-In Parallel Circuit) | 16 - Boom Anti-Drift Valve (Check Valve)           | 28 - Check Valve (Auxiliary Flow Combining Circuit)            | 40 - Boom Flow Control Valve (Poppet Valve)      |
| 5 - Load Check Valve (Swing Tandem Circuit)           | 17 - Overload Relief Valve (Boom Mode)             | 29 - Check Valve (Bucket Flow Combining Circuit)               | 41 - Overload Relief Valve (Boom Lower)          |
| 6 - Load Check Valve (Arm 1 Tandem Circuit)           | 18 - Boom Overload Relief Control Valve            | 30 - Flow Combiner Valve                                       | 42 - Overload Relief Valve (Boom Raise)          |
| 7 - Arm Regenerative Valve (Check Valve)              | 19 - Load Check Valve (Auxiliary Tandem Circuit)   | 31 - Check Valve (Flow Combiner Valve Circuit)                 | 43 - Boom Anti-Drift Valve (Switch Valve)        |
| 8 - Arm Anti-Drift Valve (Check Valve)                | 20 - Overload Relief Valve (Auxiliary)             | 32 - Check Valve (Main Relief Pressure Flow Combining Circuit) | 44 - Boom Anti-Drift Valve (Check Valve)         |
| 9 - Arm Anti-Drift Valve (Switch Valve)               | 21 - Overload Relief Valve (Auxiliary)             | 33 - Main Relief Valve   | 45 - Arm Flow Rate Control Valve (Switch Valve)  |
| 10 - Overload Relief Valve (Arm Roll-Out)             | 22 - Load Check Valve (Auxiliary Parallel Circuit) | 34 - Load Check Valve (Bucket Parallel Circuit)                | 46 - Arm Flow Rate Control Valve (Poppet Valve)  |
| 11 - Overload Relief Valve (Arm Roll-In)              | 23 - Load Check Valve (Left Travel Tandem Circuit) | 35 - Bucket Regenerative Valve (Switch Valve)                  |  |
| 12 - Load Check Valve (Boom 2 Tandem Circuit)         | 24 - Bypass Shut-Out Valve                         | 36 - Bucket Regenerative Valve (Check Valve)                   |  |



# COMPONENT OPERATION / Control Valve

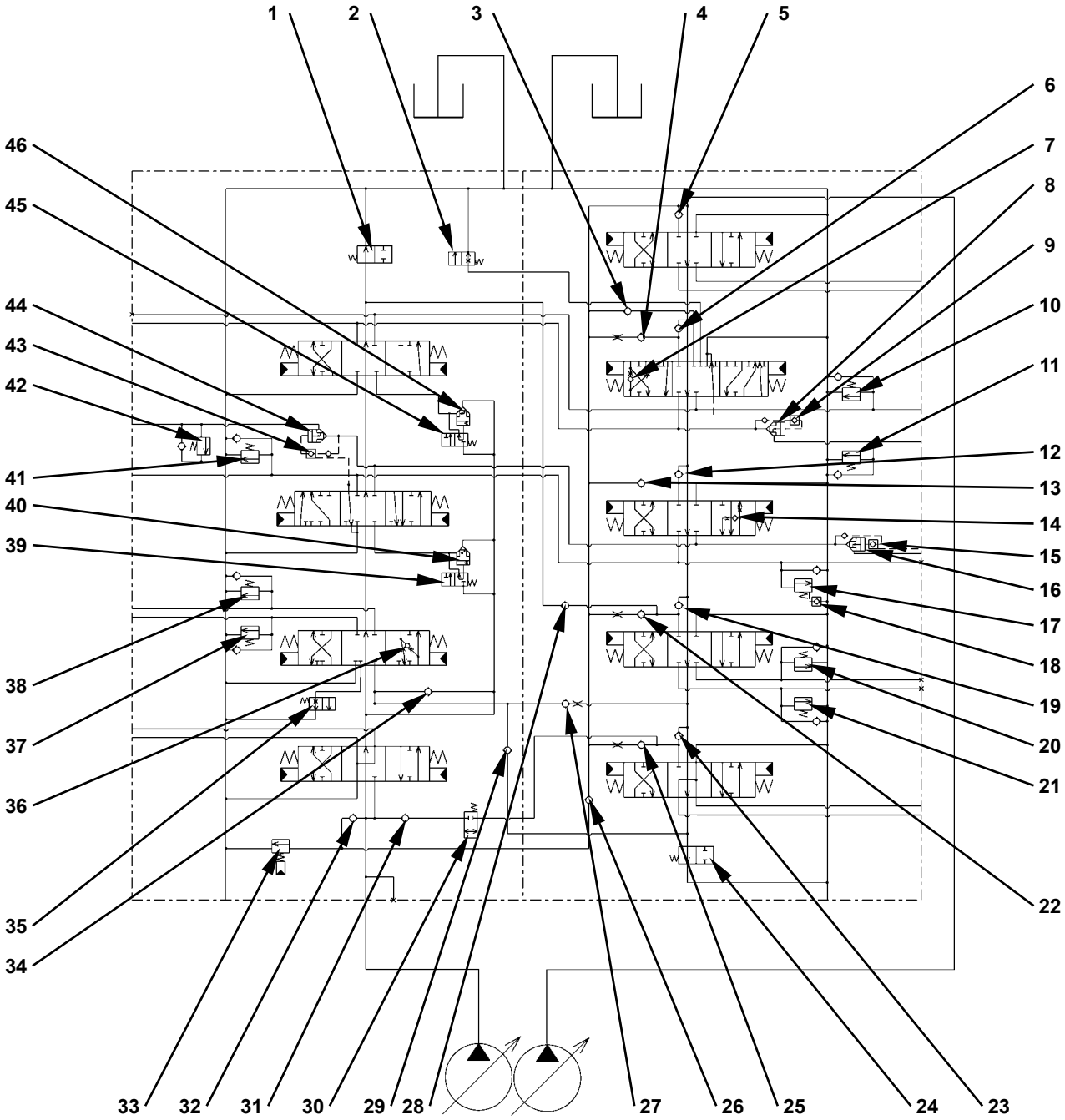

T1J7-03-03-003

# COMPONENT OPERATION / Control Valve

Cross Section C-C

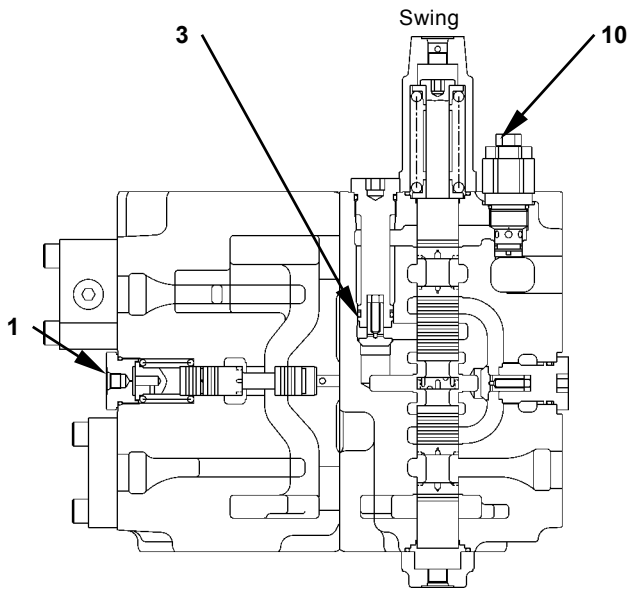

T1JB-03-03-010

Cross Section D-D

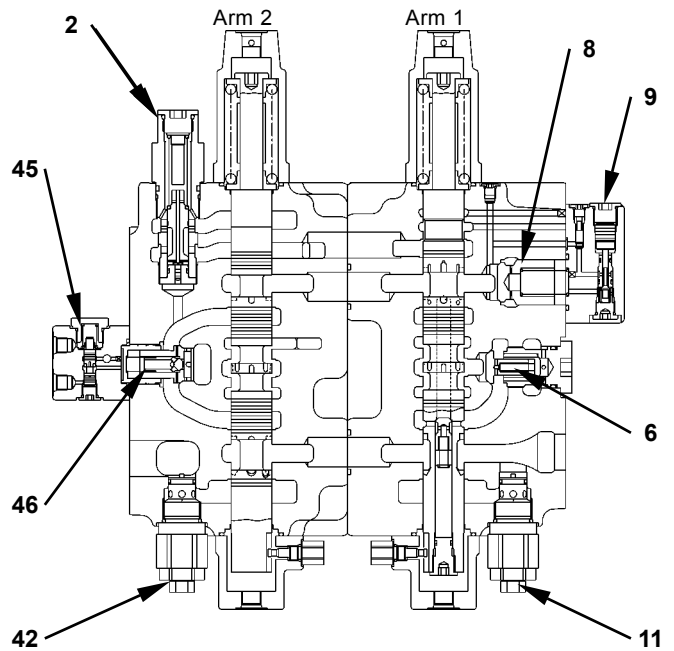

T1JB-03-03-009

- |   |  |  |  |
|---|--|--|--|
| 1 - Bypass Shut-Out Valve                             | 13 - Load Check Valve (Boom 2 Parallel Circuit)    | 25 - Load Check Valve (Left Travel Parallel Circuit)           | 37 - Overload Relief Valve (Bucket Roll-Out)     |
| 2 - Arm Regenerative Valve (Switch Valve)             | 14 - Boom Regenerative Valve                       | 26 - Check Valve (Main Relief Pressure Flow Combining Circuit) | 38 - Overload Relief Valve (Bucket Roll-In)      |
| 3 - Check Valve (Arm 1 Roll-Out Parallel Circuit)     | 15 - Boom Anti-Drift Valve (Switch Valve)          | 27 - Check Valve (Bucket Flow Combining Circuit)               | 39 - Boom Flow Rate Control Valve (Switch Valve) |
| 4 - Load Check Valve (Arm 1 Roll-In Parallel Circuit) | 16 - Boom Anti-Drift Valve (Check Valve)           | 28 - Check Valve (Auxiliary Flow Combining Circuit)            | 40 - Boom Flow Control Valve (Poppet Valve)      |
| 5 - Load Check Valve (Swing Tandem Circuit)           | 17 - Overload Relief Valve (Boom Mode)             | 29 - Check Valve (Bucket Flow Combining Circuit)               | 41 - Overload Relief Valve (Boom Lower)          |
| 6 - Load Check Valve (Arm 1 Tandem Circuit)           | 18 - Boom Overload Relief Control Valve            | 30 - Flow Combiner Valve                                       | 42 - Overload Relief Valve (Boom Raise)          |
| 7 - Arm Regenerative Valve (Check Valve)              | 19 - Load Check Valve (Auxiliary Tandem Circuit)   | 31 - Check Valve (Flow Combiner Valve Circuit)                 | 43 - Boom Anti-Drift Valve (Switch Valve)        |
| 8 - Arm Anti-Drift Valve (Check Valve)                | 20 - Overload Relief Valve (Auxiliary)             | 32 - Check Valve (Main Relief Pressure Flow Combining Circuit) | 44 - Boom Anti-Drift Valve (Check Valve)         |
| 9 - Arm Anti-Drift Valve (Switch Valve)               | 21 - Overload Relief Valve (Auxiliary)             | 33 - Main Relief Valve   | 45 - Arm Flow Rate Control Valve (Switch Valve)  |
| 10 - Overload Relief Valve (Arm Roll-Out)             | 22 - Load Check Valve (Auxiliary Parallel Circuit) | 34 - Load Check Valve (Bucket Parallel Circuit)                | 46 - Arm Flow Rate Control Valve (Poppet Valve)  |
| 11 - Overload Relief Valve (Arm Roll-In)              | 23 - Load Check Valve (Left Travel Tandem Circuit) | 35 - Bucket Regenerative Valve (Switch Valve)                  |  |
| 12 - Load Check Valve (Boom 2 Tandem Circuit)         | 24 - Bypass Shut-Out Valve                         | 36 - Bucket Regenerative Valve (Check Valve)                   |  |

# COMPONENT OPERATION / Control Valve

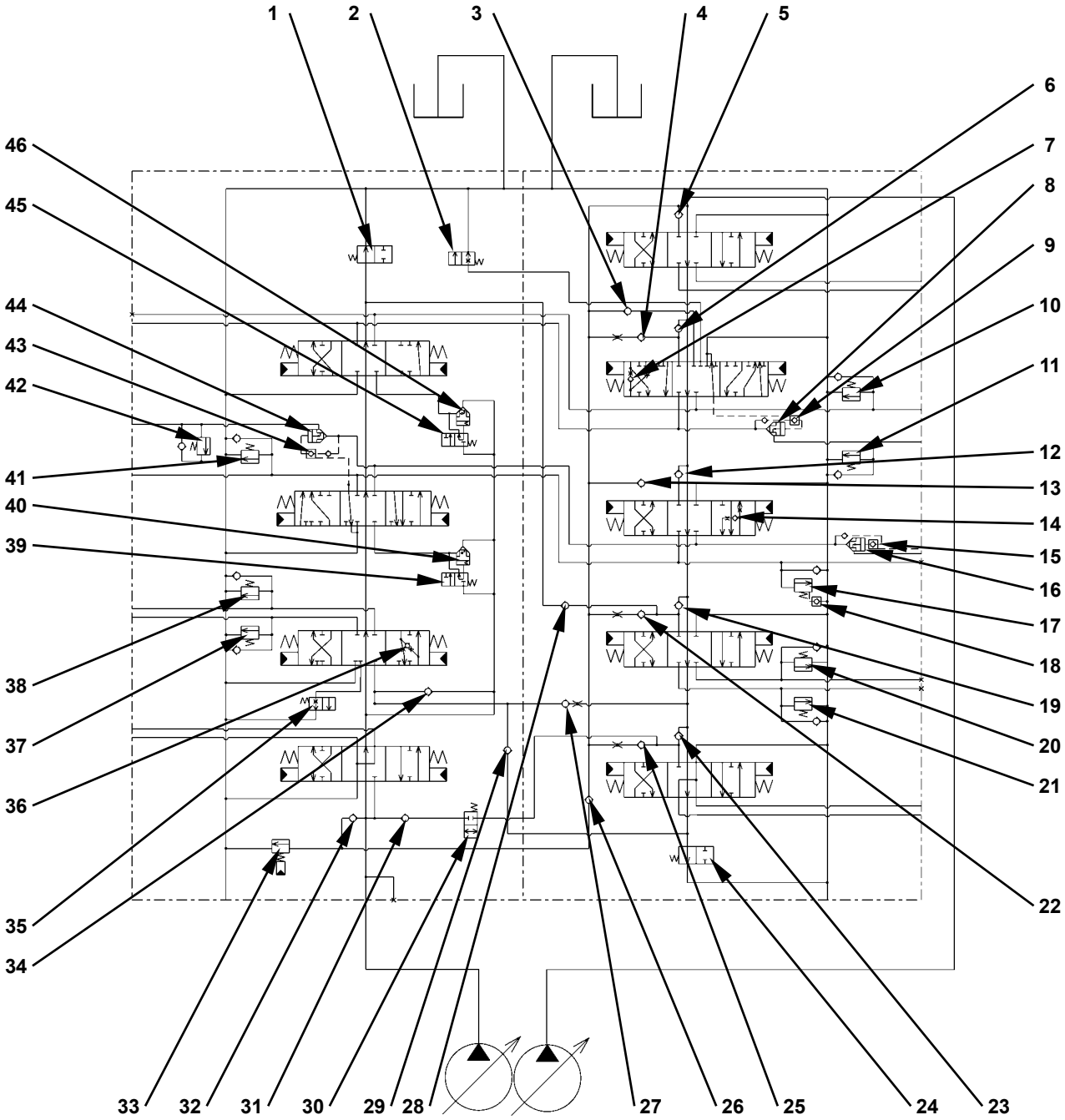

T1J7-03-03-003

# COMPONENT OPERATION / Control Valve

Cross Section E-E

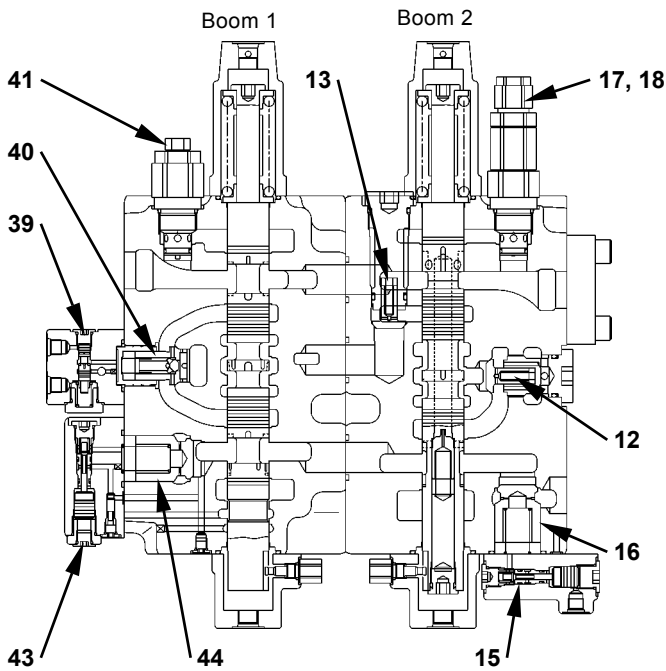

T1JB-03-03-008

Cross Section F-F

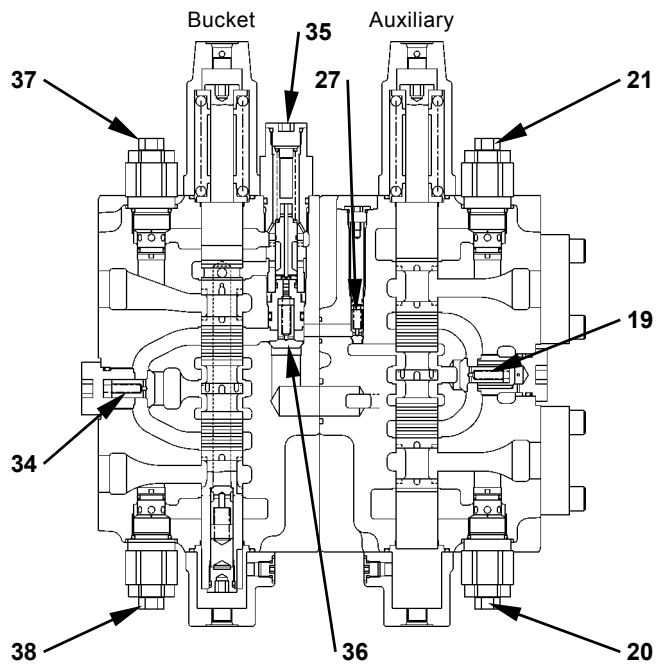

T450-03-03-014

- |   |  |  |  |
|---|--|--|--|
| 1 - Bypass Shut-Out Valve                             | 13 - Load Check Valve (Boom 2 Parallel Circuit)    | 25 - Load Check Valve (Left Travel Parallel Circuit)           | 37 - Overload Relief Valve (Bucket Roll-Out)     |
| 2 - Arm Regenerative Valve (Switch Valve)             | 14 - Boom Regenerative Valve                       | 26 - Check Valve (Main Relief Pressure Flow Combining Circuit) | 38 - Overload Relief Valve (Bucket Roll-In)      |
| 3 - Check Valve (Arm 1 Roll-Out Parallel Circuit)     | 15 - Boom Anti-Drift Valve (Switch Valve)          | 27 - Check Valve (Bucket Flow Combining Circuit)               | 39 - Boom Flow Rate Control Valve (Switch Valve) |
| 4 - Load Check Valve (Arm 1 Roll-In Parallel Circuit) | 16 - Boom Anti-Drift Valve (Check Valve)           | 28 - Check Valve (Auxiliary Flow Combining Circuit)            | 40 - Boom Flow Control Valve (Poppet Valve)      |
| 5 - Load Check Valve (Swing Tandem Circuit)           | 17 - Overload Relief Valve (Boom Mode)             | 29 - Check Valve (Bucket Flow Combining Circuit)               | 41 - Overload Relief Valve (Boom Lower)          |
| 6 - Load Check Valve (Arm 1 Tandem Circuit)           | 18 - Boom Overload Relief Control Valve            | 30 - Flow Combiner Valve                                       | 42 - Overload Relief Valve (Boom Raise)          |
| 7 - Arm Regenerative Valve (Check Valve)              | 19 - Load Check Valve (Auxiliary Tandem Circuit)   | 31 - Check Valve (Flow Combiner Valve Circuit)                 | 43 - Boom Anti-Drift Valve (Switch Valve)        |
| 8 - Arm Anti-Drift Valve (Check Valve)                | 20 - Overload Relief Valve (Auxiliary)             | 32 - Check Valve (Main Relief Pressure Flow Combining Circuit) | 44 - Boom Anti-Drift Valve (Check Valve)         |
| 9 - Arm Anti-Drift Valve (Switch Valve)               | 21 - Overload Relief Valve (Auxiliary)             | 33 - Main Relief Valve   | 45 - Arm Flow Rate Control Valve (Switch Valve)  |
| 10 - Overload Relief Valve (Arm Roll-Out)             | 22 - Load Check Valve (Auxiliary Parallel Circuit) | 34 - Load Check Valve (Bucket Parallel Circuit)                | 46 - Arm Flow Rate Control Valve (Poppet Valve)  |
| 11 - Overload Relief Valve (Arm Roll-In)              | 23 - Load Check Valve (Left Travel Tandem Circuit) | 35 - Bucket Regenerative Valve (Switch Valve)                  |  |
| 12 - Load Check Valve (Boom 2 Tandem Circuit)         | 24 - Bypass Shut-Out Valve                         | 36 - Bucket Regenerative Valve (Check Valve)                   |  |

# COMPONENT OPERATION / Control Valve

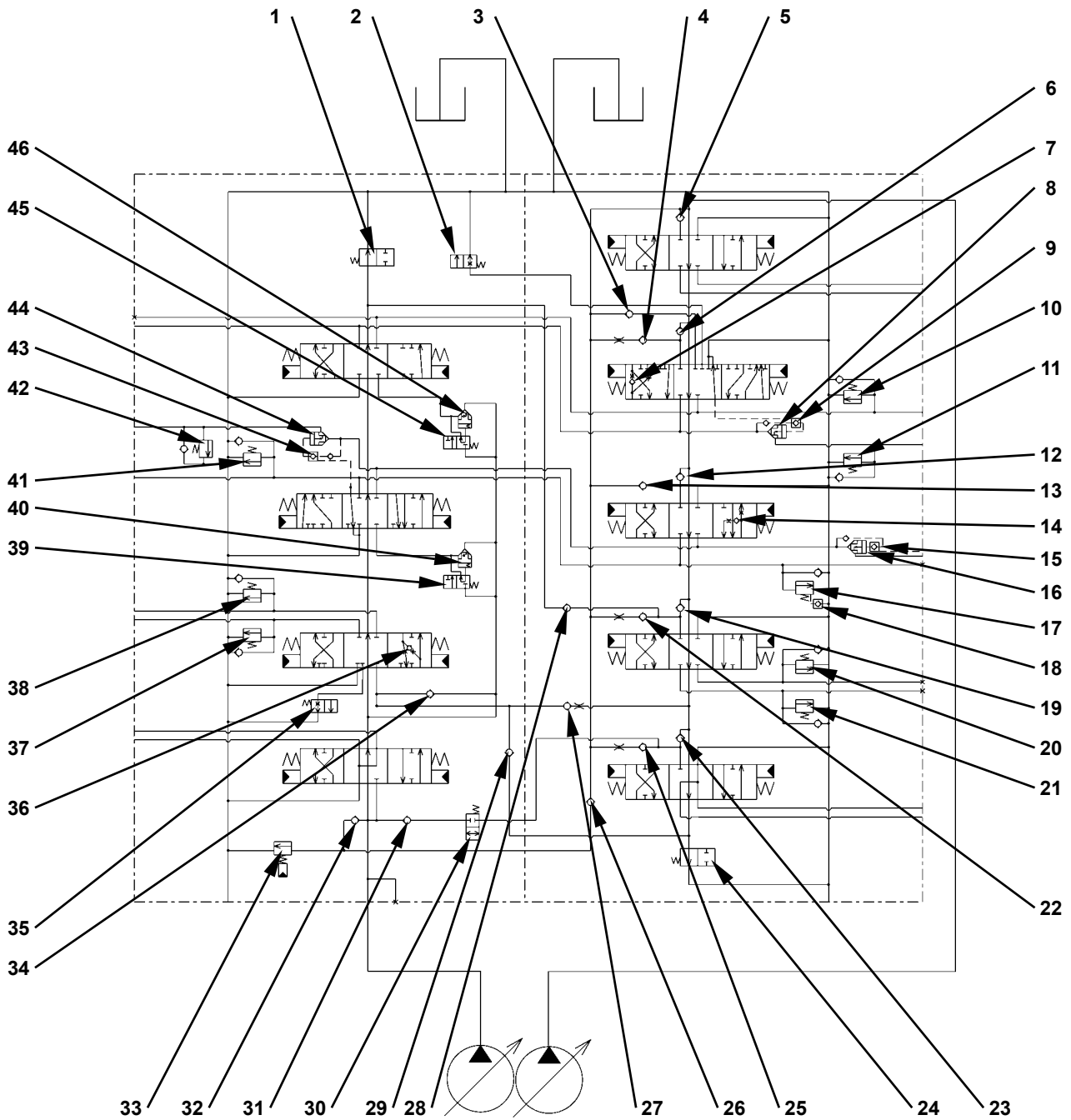

T1J7-03-03-003

# COMPONENT OPERATION / Control Valve

Cross Section G-G

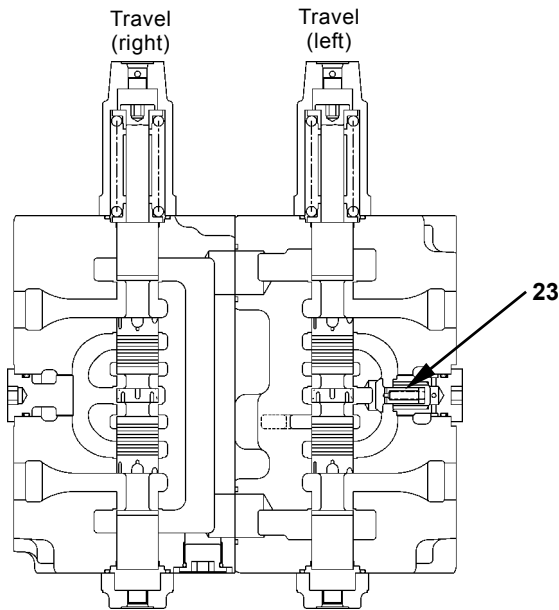

T450-03-03-013

Cross Section H-H

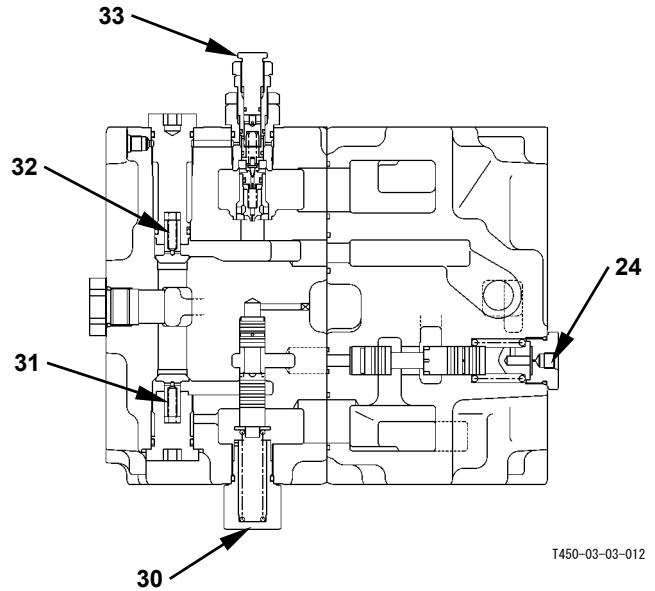

T450-03-03-012

- |   |  |  |  |
|---|--|--|--|
| 1 - Bypass Shut-Out Valve                             | 13 - Load Check Valve (Boom 2 Parallel Circuit)    | 25 - Load Check Valve (Left Travel Parallel Circuit)           | 37 - Overload Relief Valve (Bucket Roll-Out)     |
| 2 - Arm Regenerative Valve (Switch Valve)             | 14 - Boom Regenerative Valve                       | 26 - Check Valve (Main Relief Pressure Flow Combining Circuit) | 38 - Overload Relief Valve (Bucket Roll-In)      |
| 3 - Check Valve (Arm 1 Roll-Out Parallel Circuit)     | 15 - Boom Anti-Drift Valve (Switch Valve)          | 27 - Check Valve (Bucket Flow Combining Circuit)               | 39 - Boom Flow Rate Control Valve (Switch Valve) |
| 4 - Load Check Valve (Arm 1 Roll-In Parallel Circuit) | 16 - Boom Anti-Drift Valve (Check Valve)           | 28 - Check Valve (Auxiliary Flow Combining Circuit)            | 40 - Boom Flow Control Valve (Poppet Valve)      |
| 5 - Load Check Valve (Swing Tandem Circuit)           | 17 - Overload Relief Valve (Boom Mode)             | 29 - Check Valve (Bucket Flow Combining Circuit)               | 41 - Overload Relief Valve (Boom Lower)          |
| 6 - Load Check Valve (Arm 1 Tandem Circuit)           | 18 - Boom Overload Relief Control Valve            | 30 - Flow Combiner Valve                                       | 42 - Overload Relief Valve (Boom Raise)          |
| 7 - Arm Regenerative Valve (Check Valve)              | 19 - Load Check Valve (Auxiliary Tandem Circuit)   | 31 - Check Valve (Flow Combiner Valve Circuit)                 | 43 - Boom Anti-Drift Valve (Switch Valve)        |
| 8 - Arm Anti-Drift Valve (Check Valve)                | 20 - Overload Relief Valve (Auxiliary)             | 32 - Check Valve (Main Relief Pressure Flow Combining Circuit) | 44 - Boom Anti-Drift Valve (Check Valve)         |
| 9 - Arm Anti-Drift Valve (Switch Valve)               | 21 - Overload Relief Valve (Auxiliary)             | 33 - Main Relief Valve   | 45 - Arm Flow Rate Control Valve (Switch Valve)  |
| 10 - Overload Relief Valve (Arm Roll-Out)             | 22 - Load Check Valve (Auxiliary Parallel Circuit) | 34 - Load Check Valve (Bucket Parallel Circuit)                | 46 - Arm Flow Rate Control Valve (Poppet Valve)  |
| 11 - Overload Relief Valve (Arm Roll-In)              | 23 - Load Check Valve (Left Travel Tandem Circuit) | 35 - Bucket Regenerative Valve (Switch Valve)                  |  |
| 12 - Load Check Valve (Boom 2 Tandem Circuit)         | 24 - Bypass Shut-Out Valve                         | 36 - Bucket Regenerative Valve (Check Valve)                   |  |

# COMPONENT OPERATION / Control Valve

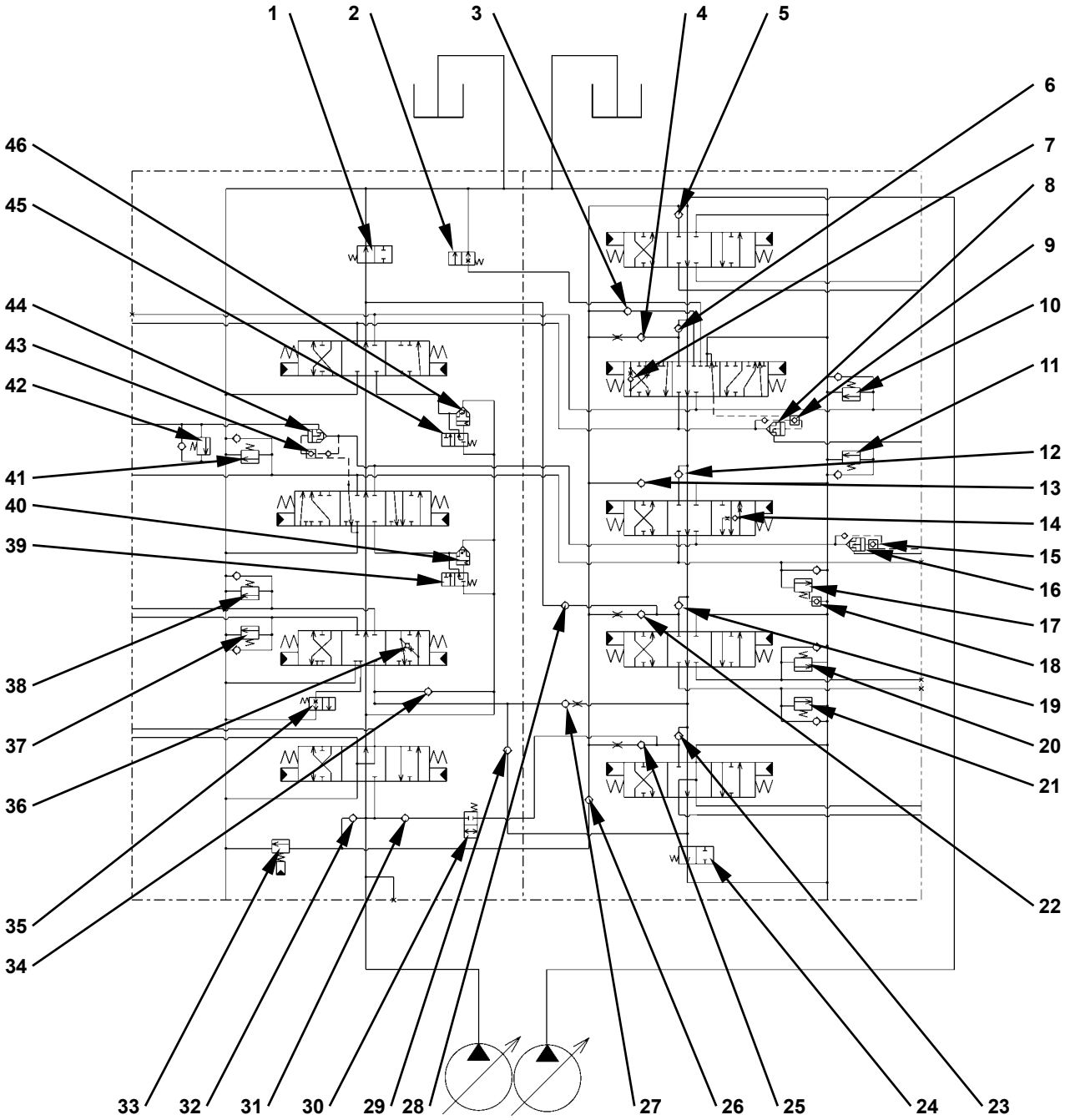

T1J7-03-03-003

## COMPONENT OPERATION / Control Valve

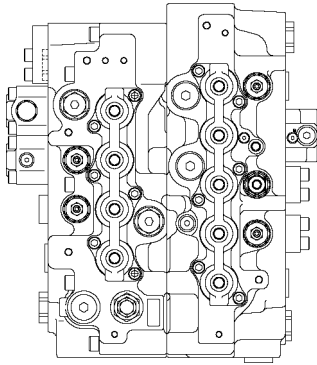

T450-03-03-001

Cross Section I-I

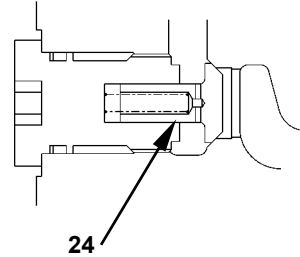

T450-03-03-008

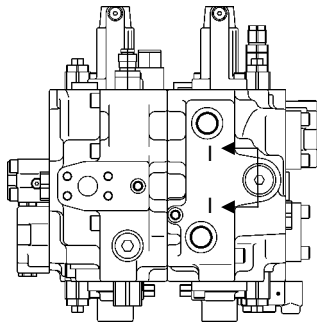

T1JB-03-03-006

- |   |  |  |  |
|---|--|--|--|
| 1 - Bypass Shut-Out Valve                             | 13 - Load Check Valve (Boom 2 Parallel Circuit)    | 25 - Load Check Valve (Left Travel Parallel Circuit)           | 37 - Overload Relief Valve (Bucket Roll-Out)     |
| 2 - Arm Regenerative Valve (Switch Valve)             | 14 - Boom Regenerative Valve                       | 26 - Check Valve (Main Relief Pressure Flow Combining Circuit) | 38 - Overload Relief Valve (Bucket Roll-In)      |
| 3 - Check Valve (Arm 1 Roll-Out Parallel Circuit)     | 15 - Boom Anti-Drift Valve (Switch Valve)          | 27 - Check Valve (Bucket Flow Combining Circuit)               | 39 - Boom Flow Rate Control Valve (Switch Valve) |
| 4 - Load Check Valve (Arm 1 Roll-In Parallel Circuit) | 16 - Boom Anti-Drift Valve (Check Valve)           | 28 - Check Valve (Auxiliary Flow Combining Circuit)            | 40 - Boom Flow Control Valve (Poppet Valve)      |
| 5 - Load Check Valve (Swing Tandem Circuit)           | 17 - Overload Relief Valve (Boom Mode)             | 29 - Check Valve (Bucket Flow Combining Circuit)               | 41 - Overload Relief Valve (Boom Lower)          |
| 6 - Load Check Valve (Arm 1 Tandem Circuit)           | 18 - Boom Overload Relief Control Valve            | 30 - Flow Combiner Valve                                       | 42 - Overload Relief Valve (Boom Raise)          |
| 7 - Arm Regenerative Valve (Check Valve)              | 19 - Load Check Valve (Auxiliary Tandem Circuit)   | 31 - Check Valve (Flow Combiner Valve Circuit)                 | 43 - Boom Anti-Drift Valve (Switch Valve)        |
| 8 - Arm Anti-Drift Valve (Check Valve)                | 20 - Overload Relief Valve (Auxiliary)             | 32 - Check Valve (Main Relief Pressure Flow Combining Circuit) | 44 - Boom Anti-Drift Valve (Check Valve)         |
| 9 - Arm Anti-Drift Valve (Switch Valve)               | 21 - Overload Relief Valve (Auxiliary)             | 33 - Main Relief Valve   | 45 - Arm Flow Rate Control Valve (Switch Valve)  |
| 10 - Overload Relief Valve (Arm Roll-Out)             | 22 - Load Check Valve (Auxiliary Parallel Circuit) | 34 - Load Check Valve (Bucket Parallel Circuit)                | 46 - Arm Flow Rate Control Valve (Poppet Valve)  |
| 11 - Overload Relief Valve (Arm Roll-In)              | 23 - Load Check Valve (Left Travel Tandem Circuit) | 35 - Bucket Regenerative Valve (Switch Valve)                  |  |
| 12 - Load Check Valve (Boom 2 Tandem Circuit)         | 24 - Bypass Shut-Out Valve                         | 36 - Bucket Regenerative Valve (Check Valve)                   |  |



## COMPONENT OPERATION / Control Valve

---

### HYDRAULIC CIRCUIT

#### **Main Circuit**

Pressure oils from pump 1 and pump 2 flow to the 4-spool section and 5-spool section of the control valve respectively.

The parallel circuit is provided in both right and left main circuits and makes the combined operation possible. The flow combining circuit is provided in both boom and arm circuits so that pressure oils from pump 1 and pump 2 are combined during a single operation.

The main relief valve is provided in the main circuit (between pump and actuator). The main relief valve works so that pressure in main circuit does not exceed the set pressure when the spool is in operation (or when the control lever is in operation).

The overload relief valve is provided in the actuator circuits (between control valve and actuator) of boom, arm, bucket and auxiliary. The overload relief valve prevents surge pressure caused by external force in the actuator circuit does not exceed the set pressure when the spool is in neutral (with the control lever in neutral).

The boom overload relief control valve is provided in the boom lower circuit of boom 2. The boom overload relief valve decreases relief set pressure of the overload relief valve and reduces vibration of machine during boom lowering operation.

# COMPONENT OPERATION / Control Valve

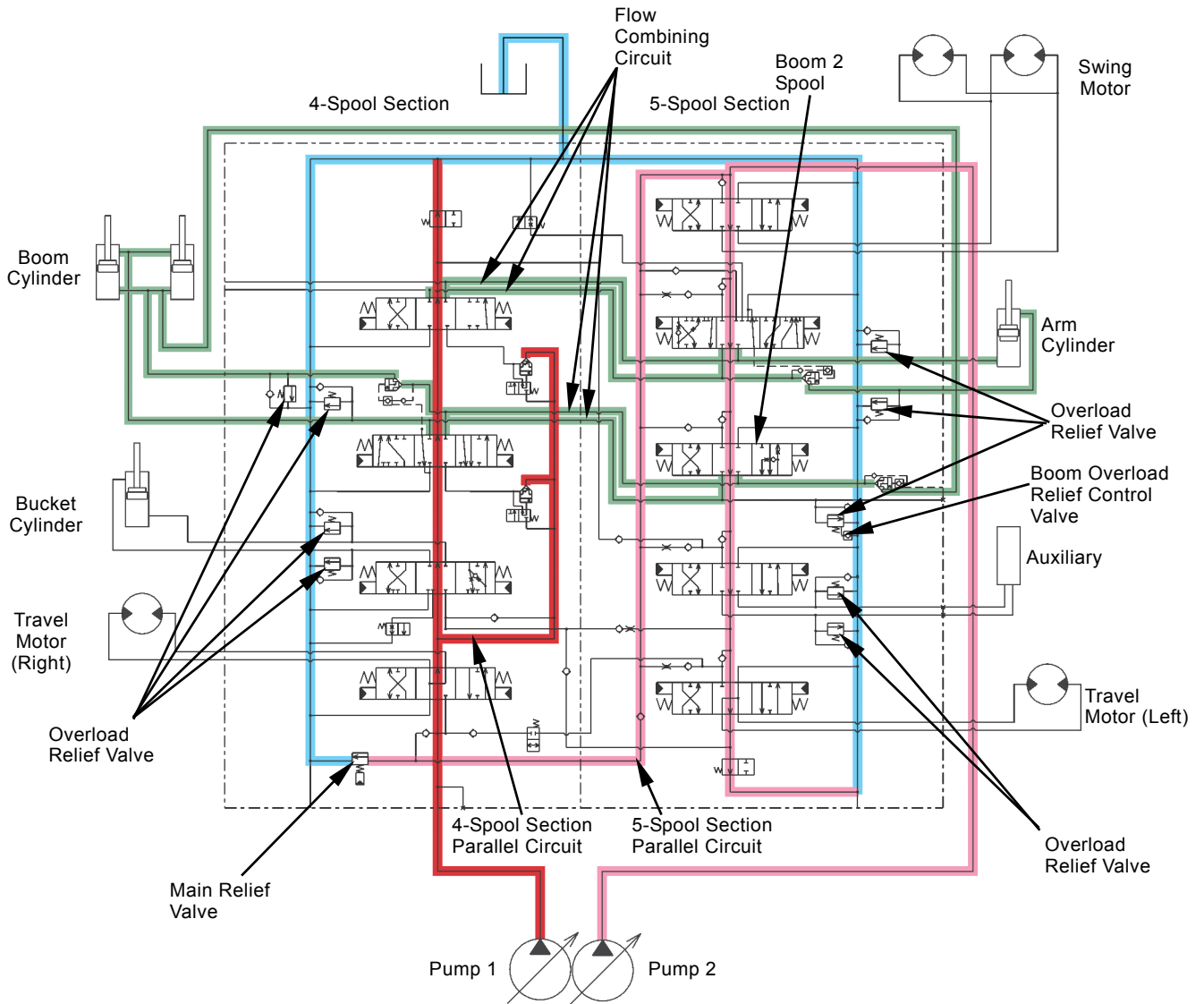

T1JB-03-03-013

## COMPONENT OPERATION / Control Valve

---

### **Pilot Control Circuit**

Pressure oil (indicated with numbers) from the pilot valve acts on the spool in control valve in order to move the spool.

In the following operations, pressure oil moves the spool and acts on the valves as follows.

- During auxiliary operation, pressure oil moves the auxiliary spool and shifts the bypass shut-out valve in 4-spool section. (Optional)

The air bleed circuit is located on the upper section of control valve and bleeds any air trapped inside automatically.

### **External Pilot Pressure Circuit**

- As the boom 1 spool is shifted during boom lower operation, pressure oil from the pilot pump acts on the boom anti-drift valve and releases the lock of boom anti-drift valve.
- As the arm 1 spool is shifted during arm roll-in operation, pressure oil from the pilot pump acts on the arm anti-drift valve and releases the lock of arm anti-drift valve.
- Pressure in the main relief valve is increased by pilot pressure from solenoid valve (SG)
- The boom overload relief control valve is shifted by pilot pressure from solenoid valve unit (SC).
- The boom flow rate control valve is shifted by pilot pressure from solenoid valve unit (SF).
- The flow combiner valve is shifted by pilot pressure from the flow combiner valve control spool in signal control valve.
- The arm flow rate control valve is shifted by pilot pressure from the arm flow rate control valve control spool in signal control valve.

# COMPONENT OPERATION / Control Valve

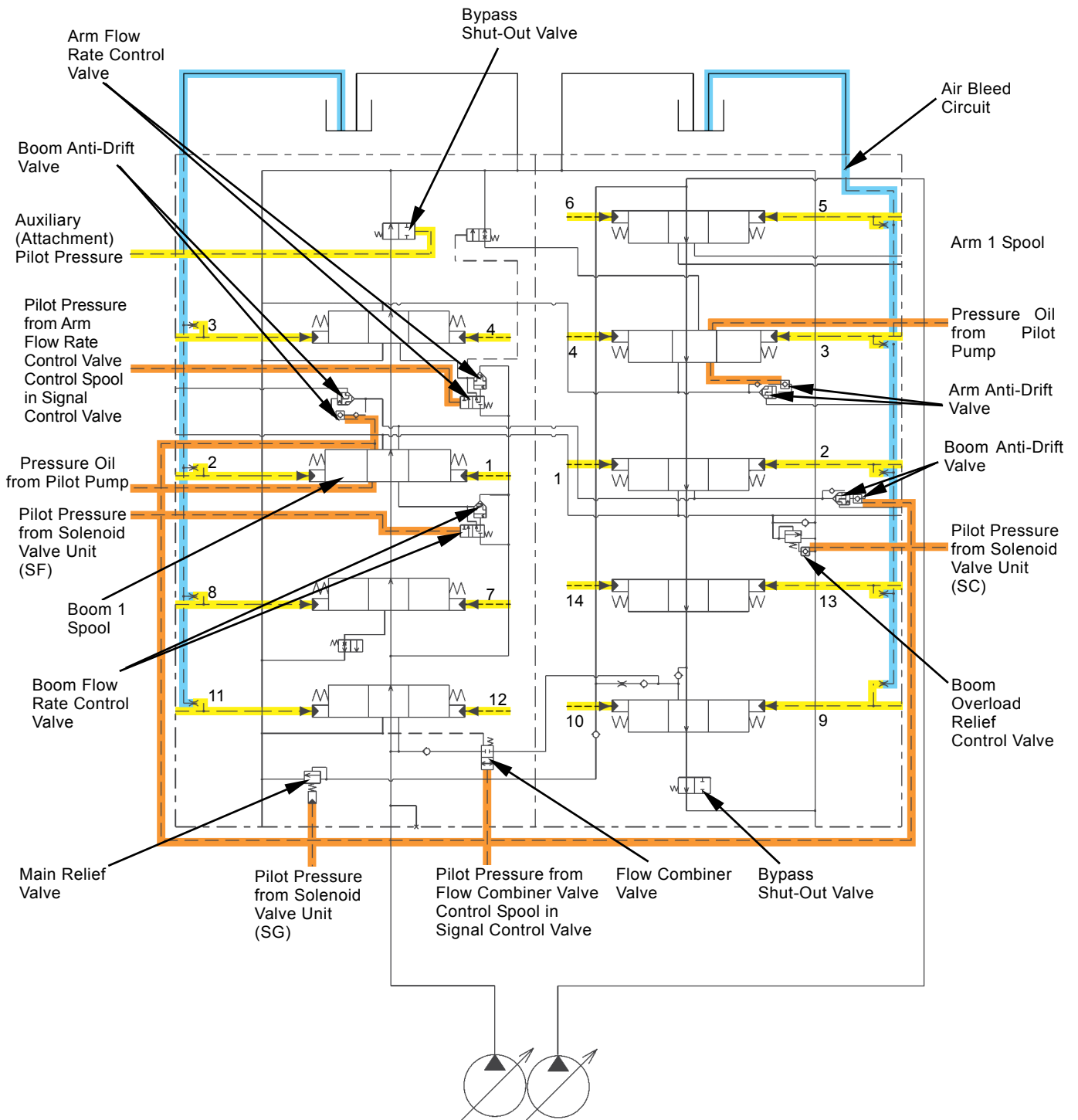

- |                  |                     |                             |                        |
|------------------|---------------------|-----------------------------|------------------------|
| 1 - Boom Raise   | 5 - Left Swing      | 9 - Travel (Left Forward)   | 13 - Auxiliary (Open)  |
| 2 - Boom Lower   | 6 - Right Swing     | 10 - Travel (Left Reverse)  | 14 - Auxiliary (Close) |
| 3 - Arm Roll-Out | 7 - Bucket Roll-In  | 11 - Travel (Right Forward) |                        |
| 4 - Arm Roll-In  | 8 - Bucket Roll-Out | 12 - Travel (Right Reverse) |                        |

**NOTE:** Yellow line : Pilot Control Circuit  
 Orange line : External Pilot Pressure Circuit

## COMPONENT OPERATION / Control Valve

---

### MAIN RELIEF VALVE

The main relief valve serves so that pressure in the main circuit does not exceed the set pressure when the actuator such as motor or cylinder is in operation. Thus, oil leak from hose and pipe joints and breakage of the actuator are prevented.

#### Relief Operation

1. Pressure in port HP (main circuit) acts on pilot poppet (6) through orifice A(1) in main poppet (3) and orifice B(4) in seat (5).
2. When pressure in port HP reaches the set pressure of spring (7), pilot poppet (6) opens and pressure oil flows to port LP (hydraulic oil tank) through passage (9).
3. At this time, a pressure difference is caused between port HP and spring chamber (10) due to orifice A(1).
4. When this pressure difference reaches the set pressure of spring (10), main poppet (3) opens and pressure oil from port HP flows to port LP.
5. As a result, pressure in the main circuit decreases.
6. When pressure in the main circuit decreases to the fixed level, main poppet (3) is closed by force of spring (10).

#### Set Pressure Increasing Operation

1. When pilot pressure from solenoid valve unit (SG) acts on port PF, spring (7) is compressed by piston (8).
2. Therefore, force of spring (7) becomes stronger.
3. Consequently, as pressure required in order to open pilot poppet (6) is increased, the relief set pressure is increased.

# COMPONENT OPERATION / Control Valve

During Relief Operation:

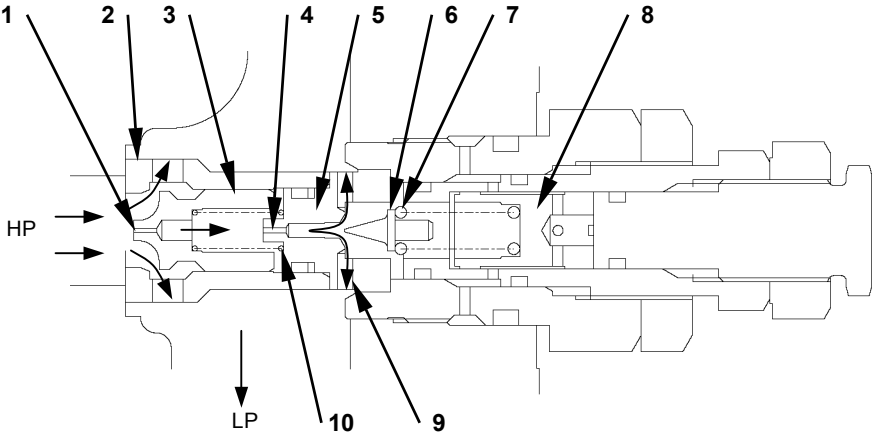

T450-03-03-031

During Set Pressure Increasing Operation:

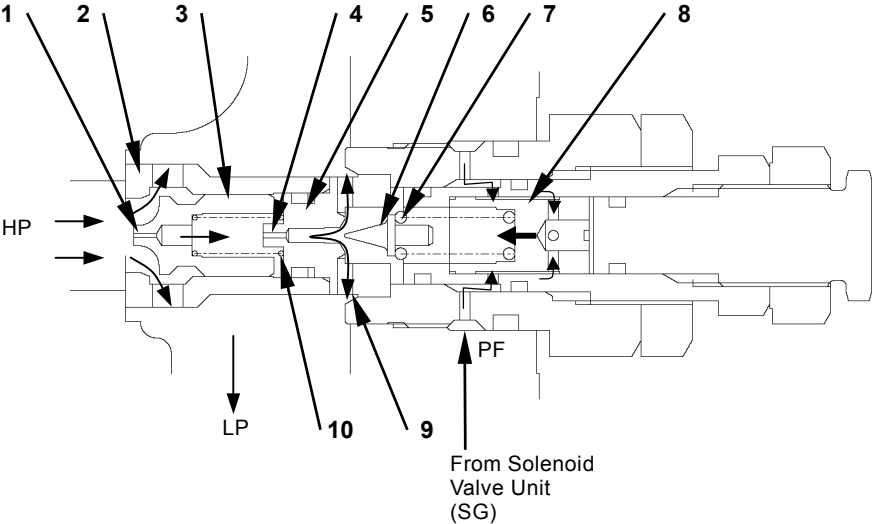

T450-03-03-032

- |                 |                  |            |             |
|-----------------|------------------|------------|-------------|
| 1 - Orifice A   | 4 - Orifice B    | 7 - Spring | 9 - Passage |
| 2 - Sleeve      | 5 - Seat         | 8 - Piston | 10 - Spring |
| 3 - Main Poppet | 6 - Pilot Poppet |            |             |

## COMPONENT OPERATION / Control Valve

---

### OVERLOAD RELIEF VALVE (WITH MAKE-UP FUNCTION)

The overload relief valves are located in the boom, arm, bucket and auxiliary circuits. The overload relief valve prevents each actuator circuit pressure from rising excessively when the actuators are moved by external force.

In addition, when the actuator circuit pressure is reduced, the overload relief valve draws hydraulic oil from the hydraulic oil tank and prevents the occurrence of cavitation. (make-up function)

#### Relief Operation

1. Pressure in port HP (actuator circuit) acts on pilot poppet (6) through orifice (1) in piston (9).
2. When pressure in port HP reaches the set pressure by spring (7), pilot poppet (6) opens, and pressure oil from passage (5) flows along the external circumference of main poppet (2), and flows to port LP (hydraulic oil tank).
3. At this time, a pressure difference is caused between port HP and spring chamber (8) due to orifice (1).
4. When this pressure difference reaches the set pressure of spring (8), piston (9) and main poppet (2) open and pressure oil from port HP flows to port LP.
5. Thereby, the actuator circuit pressure decreases.
6. When pressure in the actuator circuit decreases to the fixed level, piston (9) and main poppet (2) are closed by force of spring (8).

#### Make-Up Operation

1. When pressure in port HP (actuator circuit) decreases lower than pressure in port LP (hydraulic oil tank), main poppet (2) moves to the right.
2. Hydraulic oil flows to port HP from port LP and cavitation is prevented.
3. When pressure in port HP rises to the fixed level, main poppet (2) is closed by force of spring (4).

# COMPONENT OPERATION / Control Valve

Relief Operation:

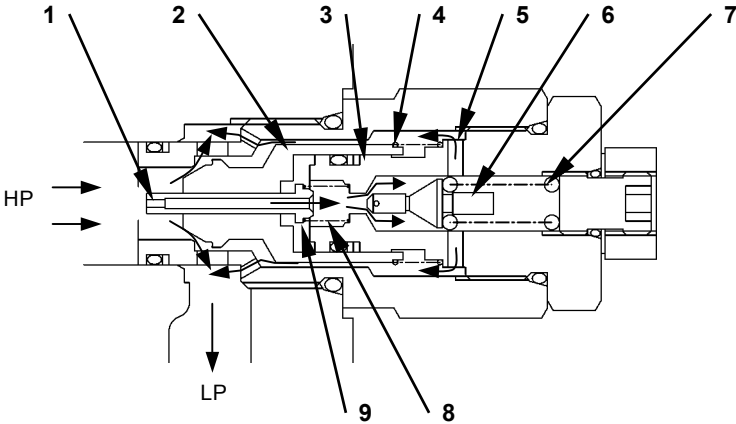

T450-03-03-033

Make-Up Operation:

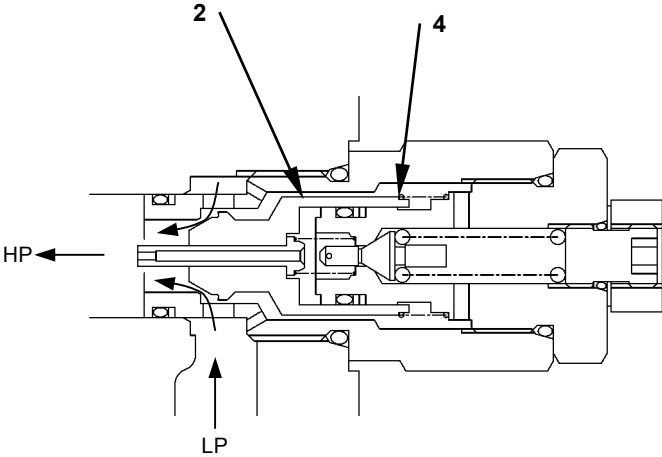

T450-03-03-034

- |                 |             |                  |            |
|-----------------|-------------|------------------|------------|
| 1 - Orifice     | 4 - Spring  | 6 - Pilot Poppet | 8 - Spring |
| 2 - Main Poppet | 5 - Passage | 7 - Spring       | 9 - Piston |
| 3 - Sleeve      |             |                  |            |



## COMPONENT OPERATION / Control Valve

---

### **BOOM OVERLOAD RELIEF CONTROL VALVE**

The boom overload relief control valve is provided in the boom lower circuit of boom 2. The boom overload relief control valve is shifted by pilot pressure from solenoid valve unit (SC) and decreases the set pressure in overload relief valve of boom cylinder rod side circuit.

Therefore, during boom lower operation, vibration of the machine is reduced. (Refer to the Control System section in SYSTEM.)

#### **Operation**

1. In normal, pressure oil in port HP flows to chamber C through piston (6) and acts on main poppet (5). Thereby, main poppet (5) is closed and the set pressure in overload relief valve is kept high.
2. When pilot pressure from solenoid valve unit (SC) acts on piston (1), piston (1) opens poppet (2). When poppet (2) opens, chambers a, b are connected to port LP through the external circumference of sleeve (7).
3. When pressure in chamber c reaches the set pressure of spring (3), pilot poppet (4) opens. When pilot poppet (4) opens, pressure in chamber c decreases, and piston (6) and main poppet (5) move to the left.
4. As main poppet (5) opens, pressure oil flows to port LP from port HP and the set pressure of overload relief valve decreases.
5. Consequently, as force in the boom cylinder rod side decreases, vibration of the machine during boom lower operation is reduced.

# COMPONENT OPERATION / Control Valve

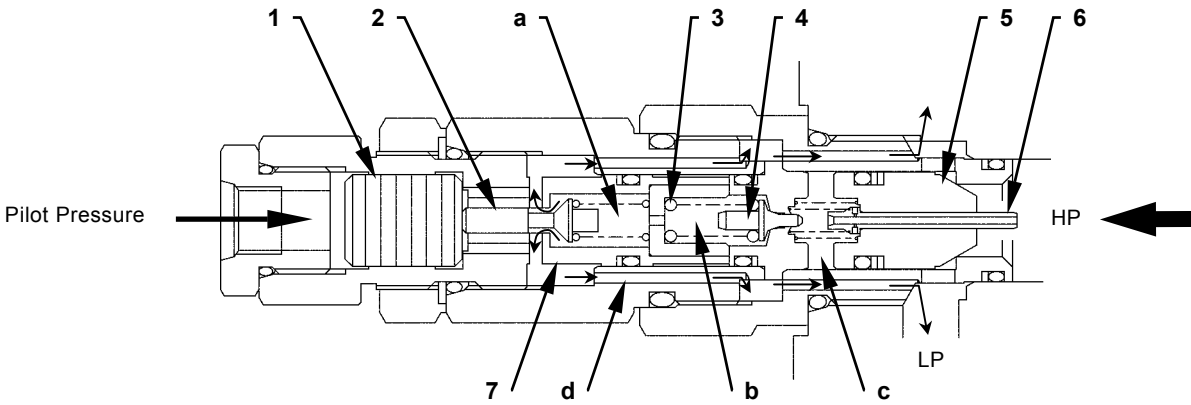

T1J1-03-03-005

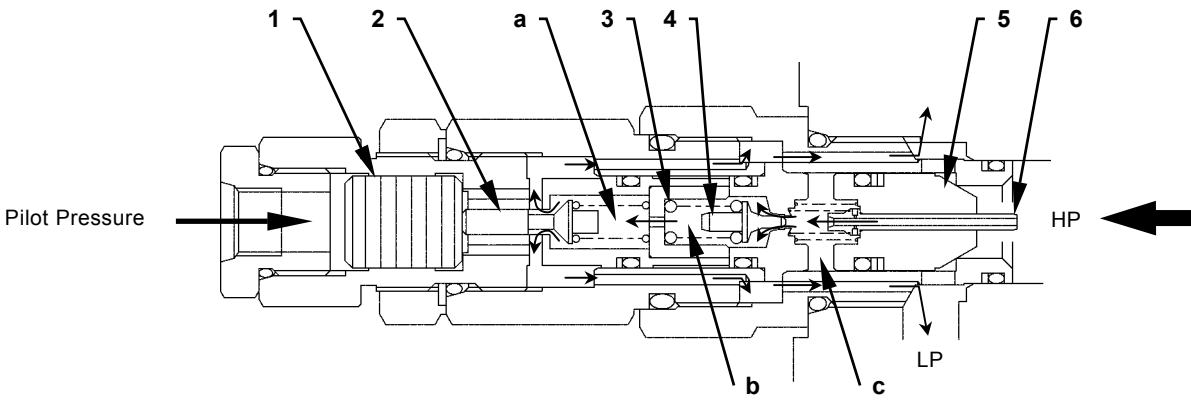

T1J1-03-03-006

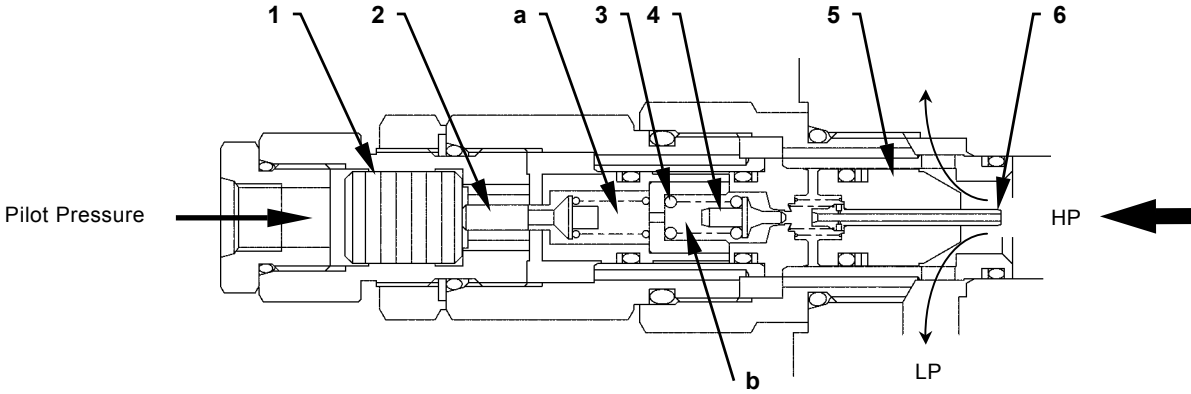

T1J1-03-03-007

- |            |                  |                 |            |
|------------|------------------|-----------------|------------|
| 1 - Piston | 3 - Spring       | 5 - Main Poppet | 7 - Sleeve |
| 2 - Poppet | 4 - Pilot Poppet | 6 - Piston      |            |

## COMPONENT OPERATION / Control Valve

### FLOW COMBINER VALVE

1. During combined operation of front attachment and travel, the flow combiner valve control spool in signal control valve is shifted and pilot pressure shifts the spool in flow combiner valve.
2. When the spool in flow combiner valve is shifted, pressure oil from pump 1 flows to the spools in right and left travels.
3. Therefore, pressure oil from pump 1 is routed to both right travel and left travel spools.
4. Pressure oil from pump 2 is routed to the front attachment and swing.  
Consequently, during combined operation of travel, front attachment and swing, the machine can travel straight.

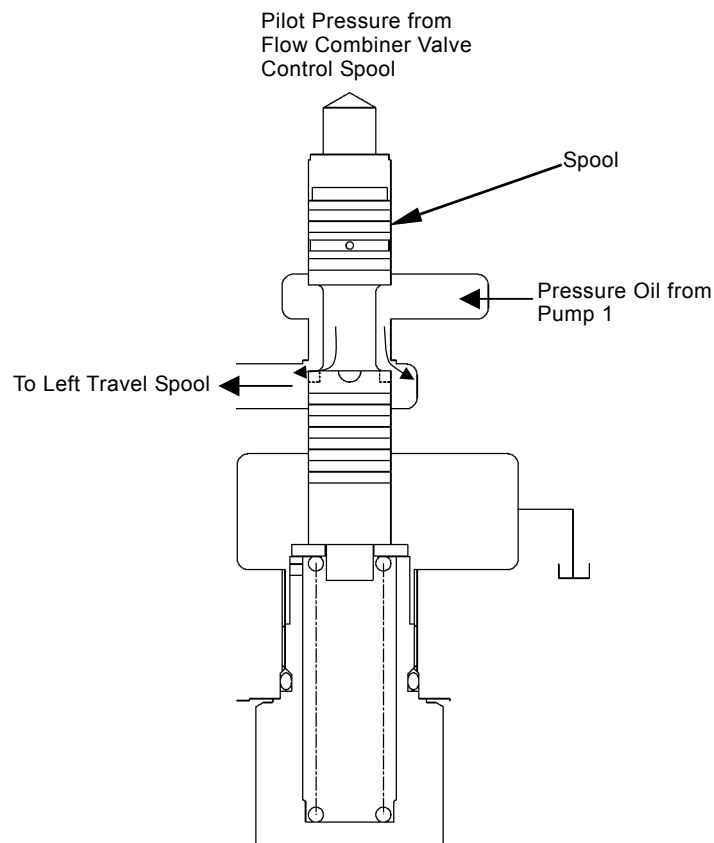

T450-03-03-035

# COMPONENT OPERATION / Control Valve

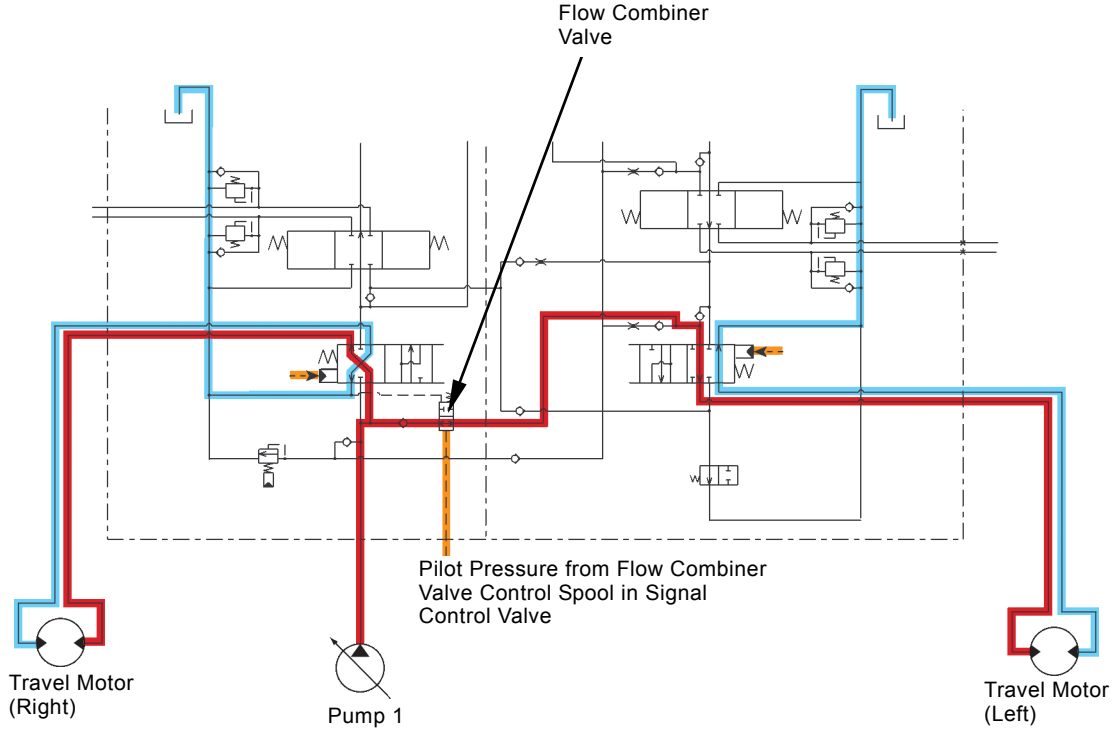

T450-03-03-036

## COMPONENT OPERATION / Control Valve

### ANTI-DRIFT VALVE

The anti-drift valve is provided in the circuits of boom cylinder bottom side and arm cylinder rod side, and prevents the cylinders from drifting.

The anti-drift valve for boom spool 1 and 2 are provided in the circuit of boom cylinder bottom side.

 **NOTE:** Both boom and arm anti-drift valves are identical in construction. Therefore, the boom anti-drift valve for boom spool 1 is explained as an example.

#### Holding Operation

1. Pressure oil from the boom cylinder bottom side flows to the spring (5) chamber and the spring (4) chamber in switch valve (3) through orifice (7) in check valve (6).
2. When the control lever in neutral (boom 1, spool (8): neutral), pressure oil from port 4Pc3 is blocked so that switch valve (3) in the anti-drift valve is not shifted.
3. Consequently, as check valve (6) is pushed by force of spring (5) and pressure of the spring (5) chamber, and the return circuit is blocked, drift amount of the cylinder is reduced.

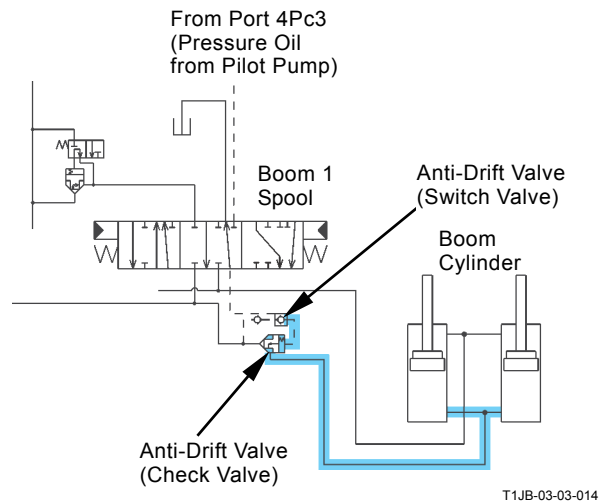

# COMPONENT OPERATION / Control Valve

Holding Operation:

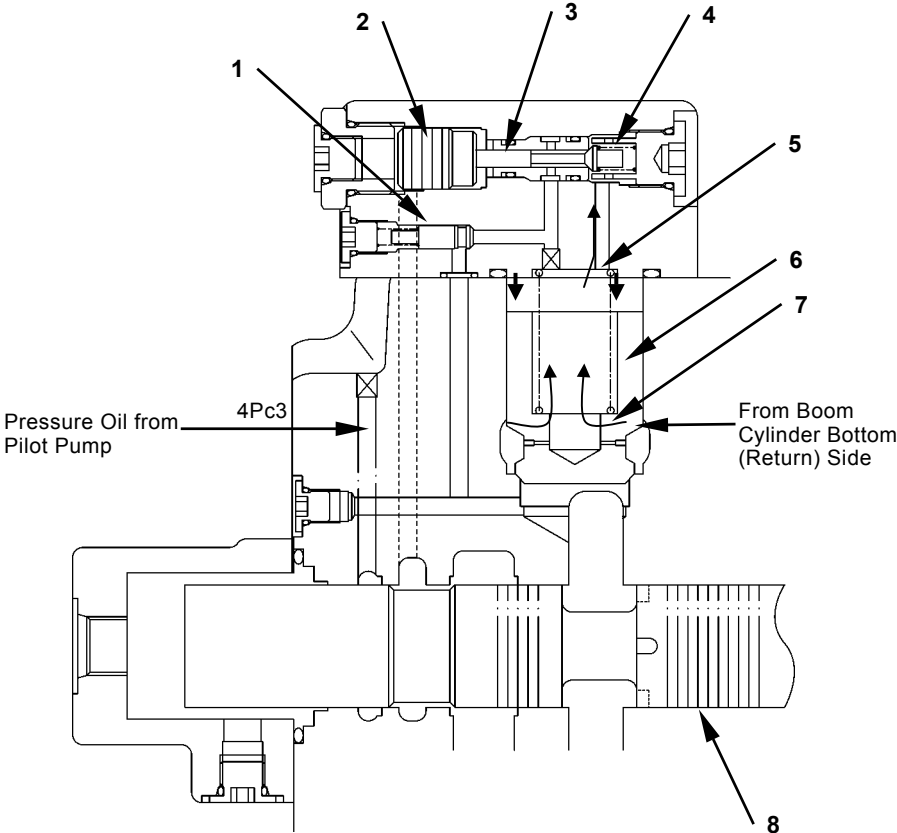

T1JB-03-03-015

- |                 |                  |                 |                  |
|-----------------|------------------|-----------------|------------------|
| 1 - Check Valve | 3 - Switch Valve | 5 - Spring      | 7 - Orifice      |
| 2 - Piston      | 4 - Spring       | 6 - Check Valve | 8 - Boom 1 Spool |

## COMPONENT OPERATION / Control Valve

### Releasing Operation

1. During boom lower operation (arm roll-in operation in case of the arm anti-drift valve), spool (8) in boom 1 moves to the left. Pressure oil from port 4Pc3 acts on piston (2) through the inner passage.
2. As piston (2) pushes switch valve (3), switch valve (3) is shifted.
3. Pressure oil in the spring (5) chamber of check valve (6) pushes to open check valve (1) through the external circumference of switch valve (3) so that pressure oil flows to the boom 2 spool (hydraulic oil tank).
4. Therefore, pressure in the spring (5) chamber decreases. At this time, a pressure difference between port 4A3 and the spring (5) chamber arises due to orifice (7) in check valve (6).
5. When this pressure difference becomes stronger than the spring (5) force, check valve (6) opens. Consequently, return oil from the boom cylinder bottom side flows to the hydraulic oil tank through the boom 2 spool.

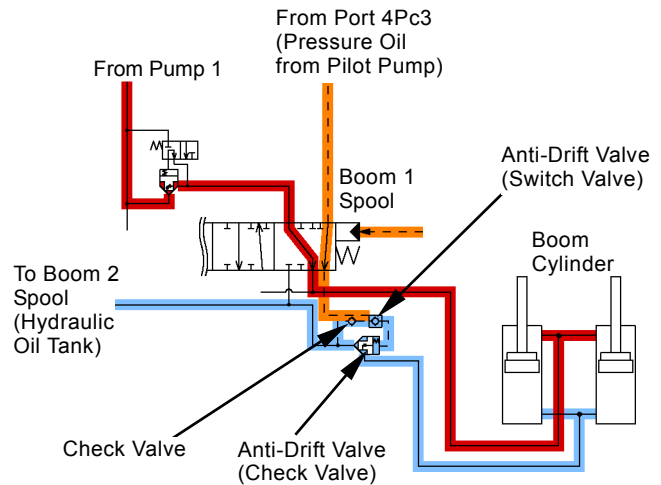

T450-03-03-038

# COMPONENT OPERATION / Control Valve

Releasing Operation:

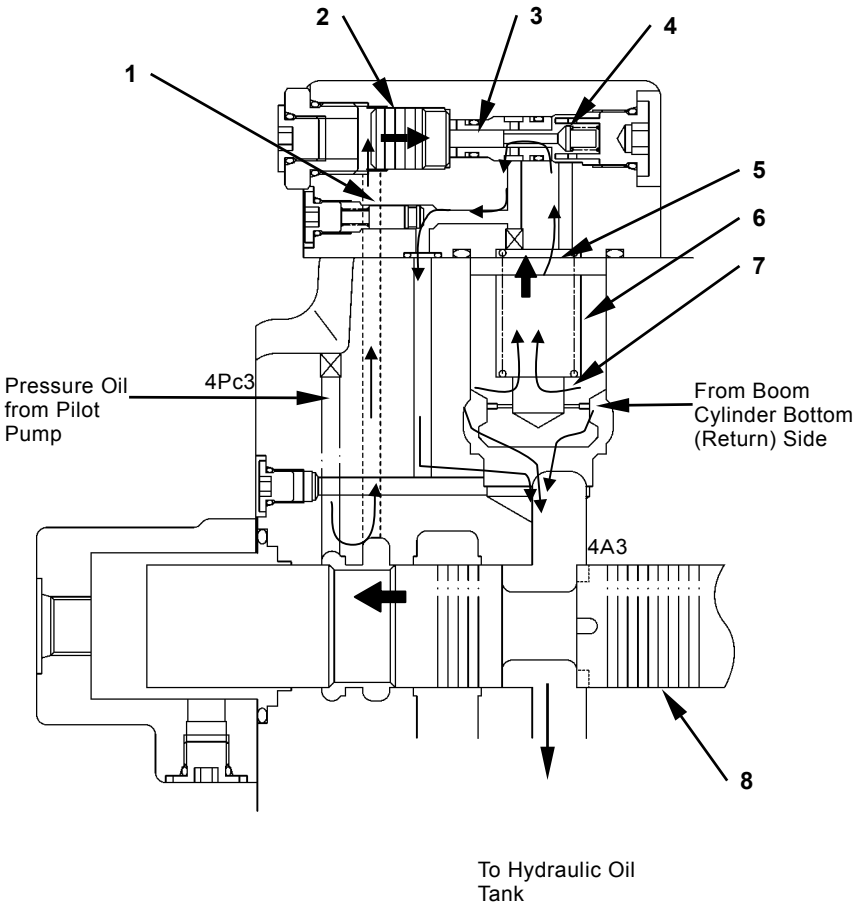

T1JB-03-03-018

- |                 |                  |                 |                  |
|-----------------|------------------|-----------------|------------------|
| 1 - Check Valve | 3 - Switch Valve | 5 - Spring      | 7 - Orifice      |
| 2 - Piston      | 4 - Spring       | 6 - Check Valve | 8 - Boom 1 Spool |



## COMPONENT OPERATION / Control Valve

### REGENERATIVE VALVE

The regenerative valves are provided in the boom lower, arm roll-in and bucket roll-in circuits. The regenerative valve increases cylinder speeds in order to cylinder hesitation, and improve machine controllability.

#### Operation of Boom Regenerative Valve

1. During boom lower operation, return oil from the cylinder bottom side enters hole on the spool and acts on the check valve.
2. During boom lower operation, the boom is lowered faster as compared with amount of supply from the pump due to boom own weight.
3. Therefore, pressure in the circuit between pump and boom cylinder rod decreases.
4. When pressure in the cylinder rod side becomes lower than that in the bottom side, the check valve opens.
5. Consequently, return oil from the cylinder bottom side flows to the rod side, is combined with pressure oil from pump 1, and is supplied to the cylinder rod side so that the regenerative operation is done.
6. Therefore, speed of the cylinder increases.
7. When the cylinder is moved full stroke or the load increases, pressure in the cylinder rod side circuit increases more than that in the bottom side.
8. Consequently, the check valve is closed and regenerative operation stops.

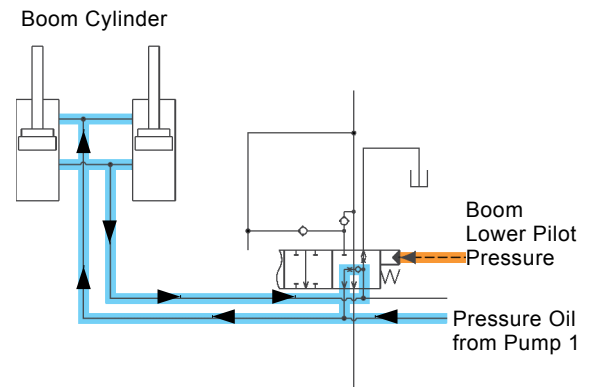

T450-03-03-041

# COMPONENT OPERATION / Control Valve

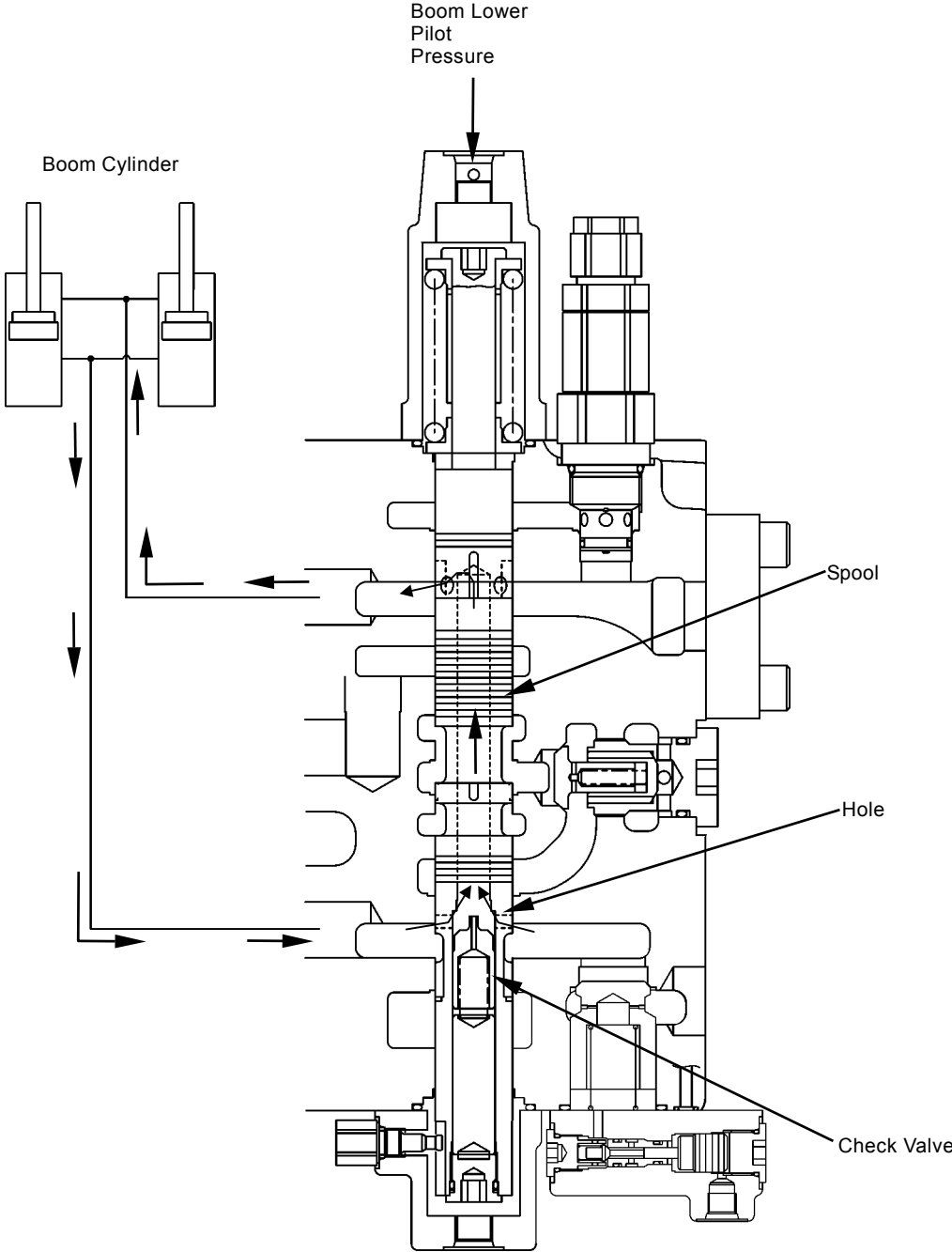

T1JB-03-03-019

## COMPONENT OPERATION / Control Valve

### Arm Regenerative Valve and Bucket Regenerative Valve

 **NOTE:** Operational principle of the arm regenerative valve is identical to that of the bucket regenerative valve. Therefore, the bucket regenerative valve is explained as an example.

#### Operation

1. During bucket digging operation (arm roll-in operation in case of the arm regenerative valve), return oil from the cylinder rod side flows to the hydraulic oil tank through external circumference of the plunger in switch valve and hole on the sleeve.
2. Return oil from the cylinder rod enters hole on the spool and acts on the check valve through spool inside.
3. When digging operation is done with the bucket rolled-out, the bucket moves faster as compared with pressure oil supply from the pump.
4. Therefore, pressure in the circuit between pump and bucket cylinder bottom decreases.
5. When pressure in the cylinder bottom side becomes lower than that in the rod side, the check valve opens.
6. Therefore, return oil from the cylinder rod side flows to the bottom side, is combined with pressure oil from the pump, and is supplied to the cylinder bottom side.
7. Consequently, the regenerative operation is done and speed of the cylinder increases.
8. When the cylinder is moved full stroke or the digging load increases, pressure in the cylinder bottom side circuit increases more than the rod side.
9. Therefore, the check valve is closed and the regenerative operation stops.
10. As pressure in the cylinder bottom side circuit increases, the piston of switch valve pushes the plunger.
11. Consequently, as amount of oil which flows to the hydraulic oil tank from the cylinder rod side increases, speed of the cylinder is kept increasing in spite of overload state.

#### During Regenerative Operation:

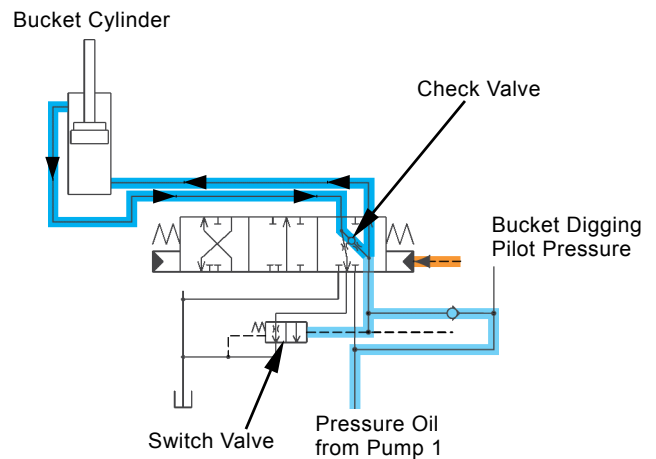

#### During Normal Operation:

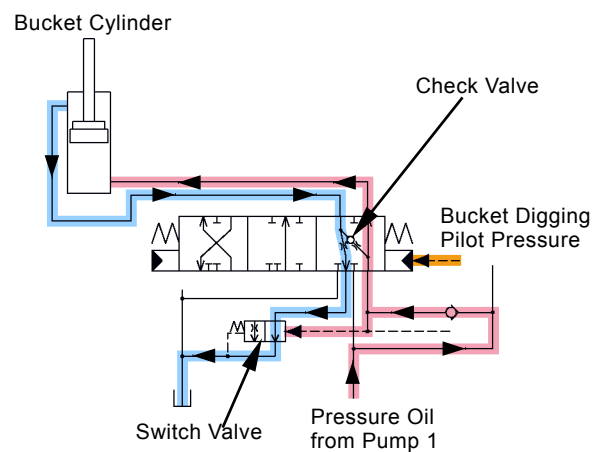

# COMPONENT OPERATION / Control Valve

During Regenerative Operation:

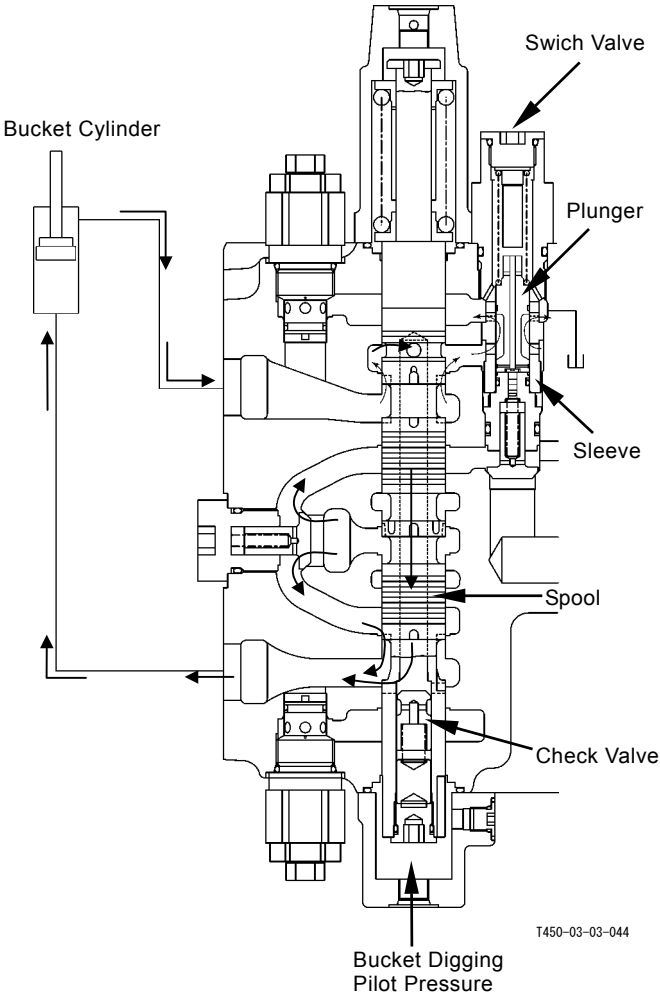

During Normal Operation:

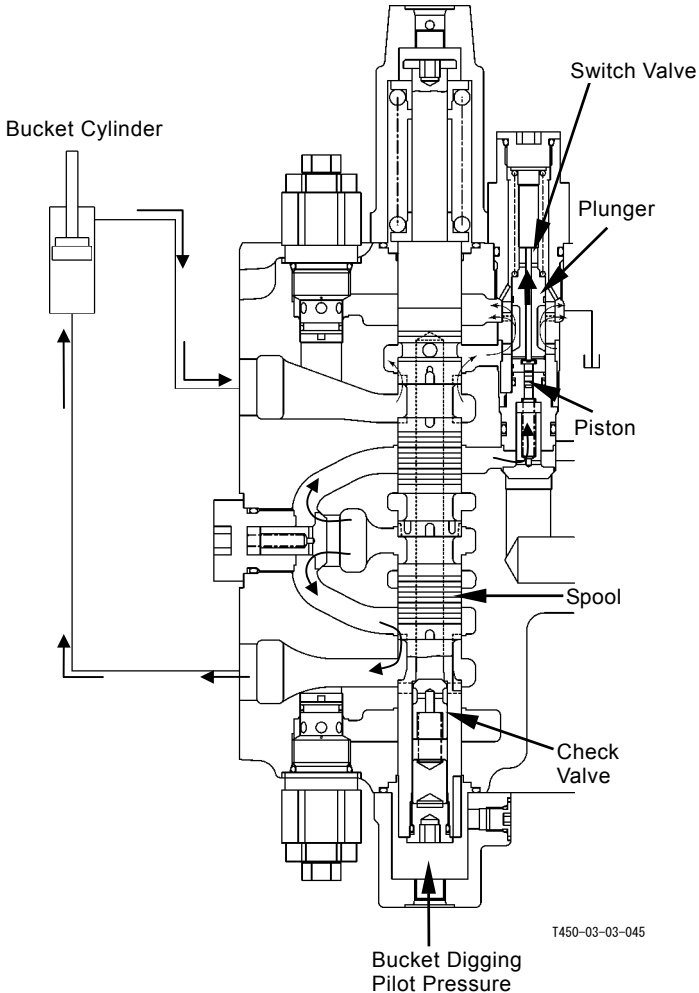

## COMPONENT OPERATION / Control Valve

### FLOW RATE CONTROL VALVE

The flow rate control valve is provided in the boom and arm circuits, restricts oil flow rate in the circuit during combined operation, and gives priority to other actuators. (Refer to the Control System, Hydraulic System groups / SYSTEM.)

Each flow rate control valve is operated during combined operation as shown below.

Flow Rate Control Valve	Combined Operation
Boom	Boom Lower + Arm (Roll-Out / In) Boom Lower + Bucket (Roll-In / Out)
Arm	Boom Raise and Arm Roll-In

 **NOTE:** The boom flow rate control valve is explained here.

#### Normal Operation

1. Pressure oil which flows to the 4-spool section parallel circuit from pump 1 is divided into the two directions.
2. One acts on the check valve A in the poppet valve. The other pushes to open check valve B and acts on the switch valve.
3. In normal, as the switch valve is kept closed, pressure oil from pump 1 is blocked by the switch valve.
4. Pressure oil from pump 1 pushes to open check valve A and the poppet, and flows to the boom 1 spool.

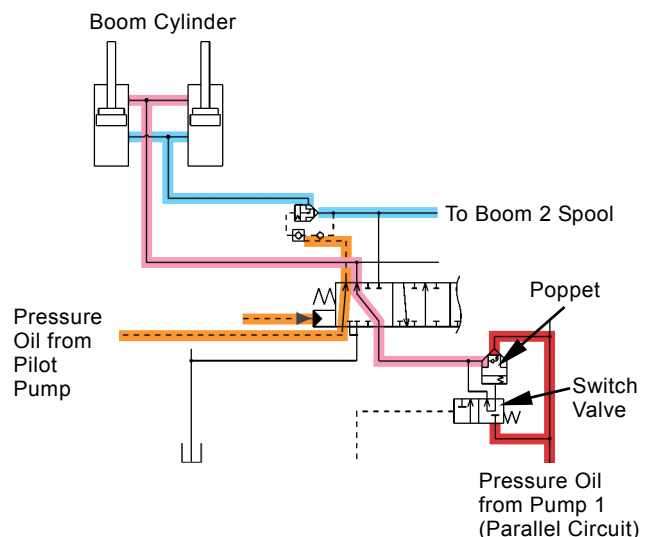

T450-03-03-046

# COMPONENT OPERATION / Control Valve

During Normal Operation:

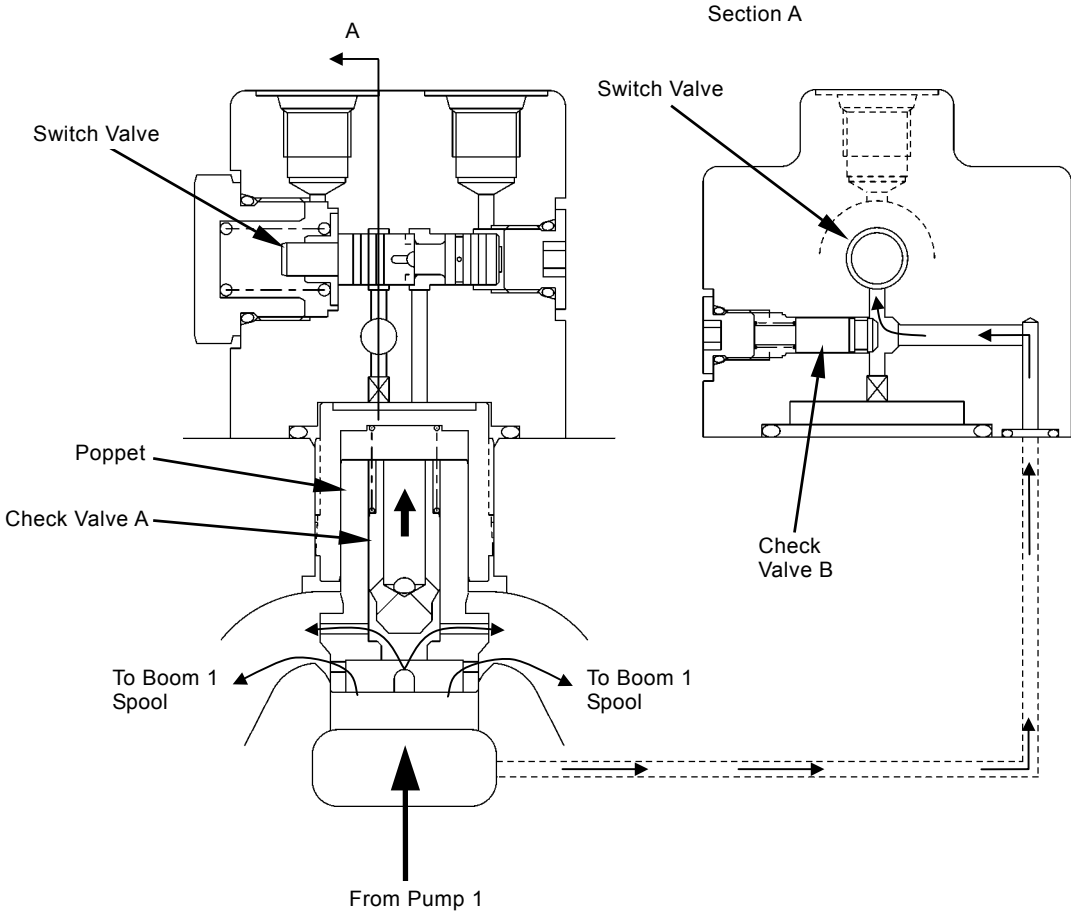

T450-03-03-048

# COMPONENT OPERATION / Control Valve

### Flow Rate Control Operation

- 1. Pilot pressure from solenoid valve unit (SF) shifts the switch valve in boom flow rate control valve.
- 2. As pressure oil from pump 1 acts on the piston through switch valve, the piston moves downward (upward in the circuit diagram).
- 3. Therefore, back pressure in the poppet increases and the force to close the poppet valve appears.
- 4. Consequently, the poppet restricts flow rate to the boom 1 spool and pressure oil is supplied to other actuators which load pressure is higher at.

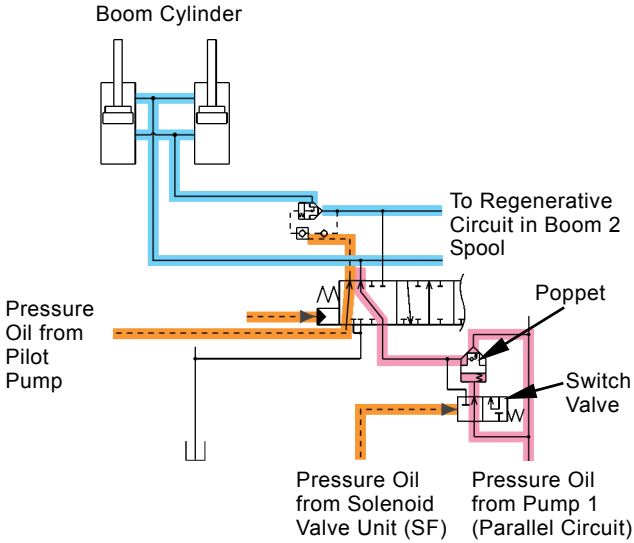

T450-03-03-047

# COMPONENT OPERATION / Control Valve

During Flow Rate Control Operation:

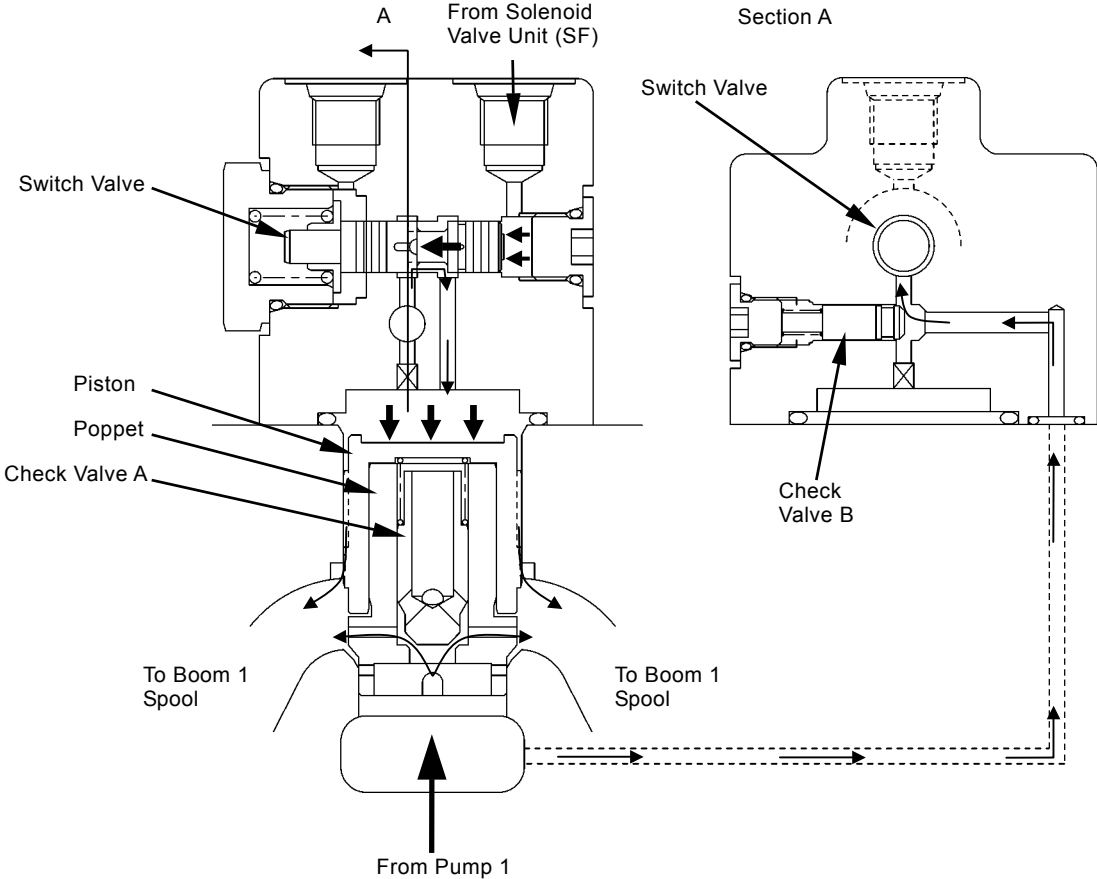

T450-03-03-049



## COMPONENT OPERATION / Control Valve

### BYPASS SHUT-OUT VALVE

The bypass shut-out valve is provided in the rear of 4-spool and 5-spool section circuits. The bypass shut-out valve blocks the neutral circuit (return circuit to hydraulic oil tank) in 4-spool and 5-spool sections so that pressure oils in pumps 1 and 2 are combined.

Therefore, amount of oil which flows to the cylinder increases and speed of the cylinder increases.

 **NOTE:** The bypass shut-out valve in 5-spool section is not used for the machine control.

#### Operation

1. When the attachment is operated on the machine equipped with a attachment (optional), pilot pressure from the pilot valve (optional) shifts the bypass shut-out valve in 4-spool section.
2. Therefore, as the neutral circuit in 4-spool section is blocked, pressure oil from pump 1 flows to the 5-spool section, is combined with pressure oil from pump 2 so that combined pressure oil is supplied to the auxiliary spool.
3. Consequently, speed of the attachment (optional) increases.

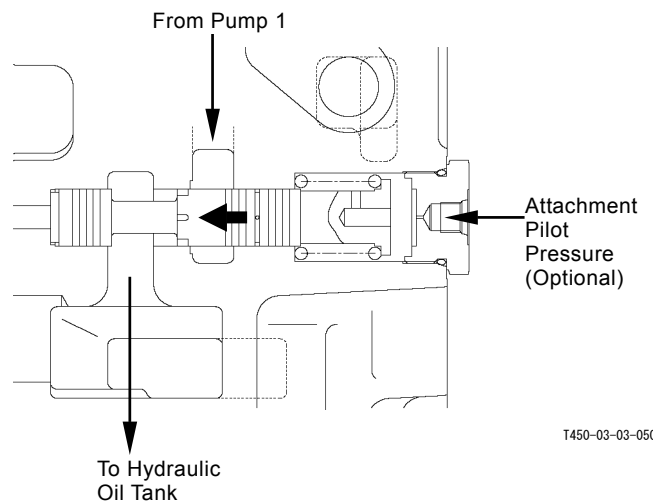

 **NOTE:** The illustration shows the bypass shut-out valve in 4-spool section.

# COMPONENT OPERATION / Control Valve

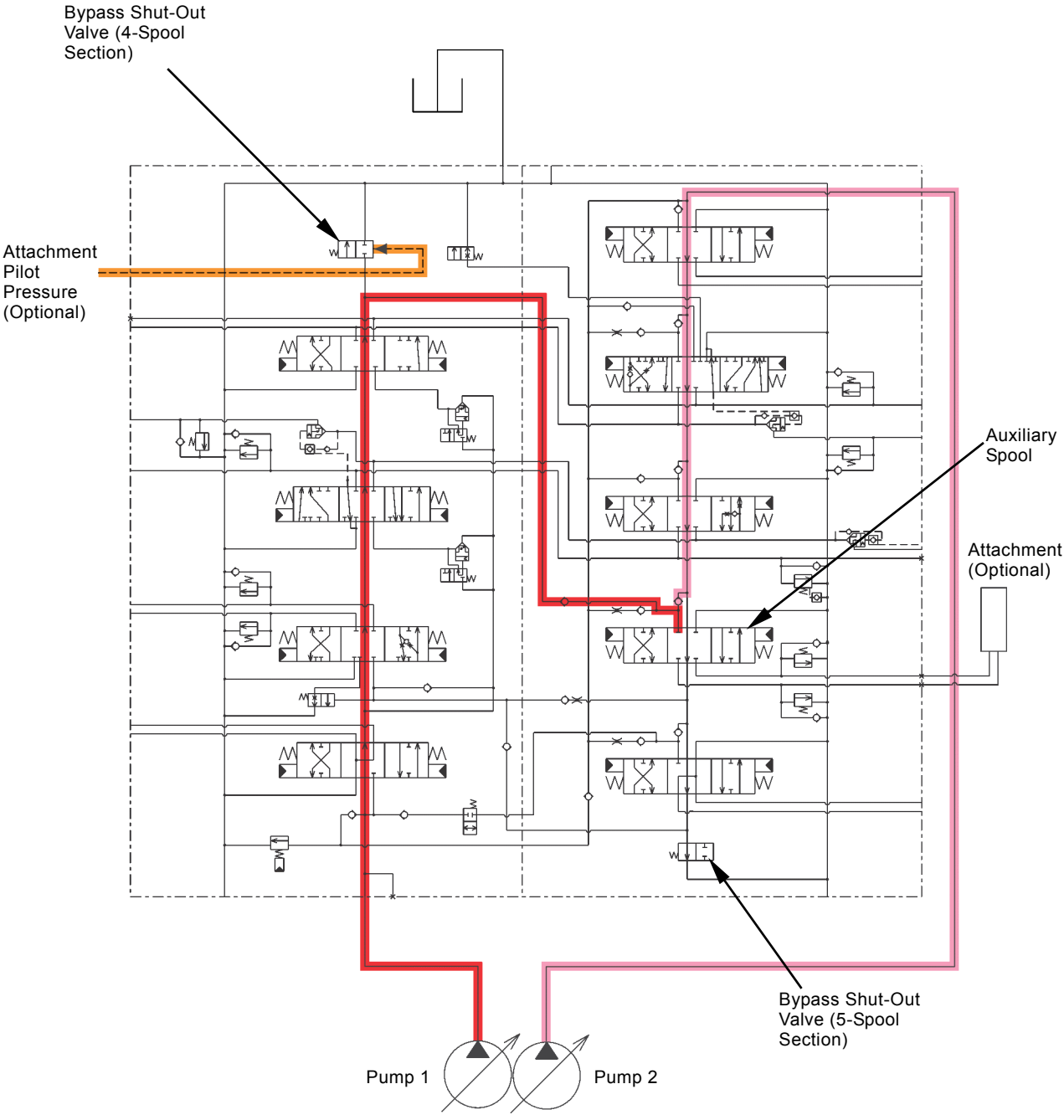

T1JB-03-03-020

## COMPONENT OPERATION / Control Valve

---

(Blank)

## COMPONENT OPERATION / Pilot Valve

### OUTLINE

The pilot valve controls pilot pressure oil in order to move spool in control valve. The pilot valve outputs pressure according to the control lever stroke by PPC (Pressure Proportional Control Valve) function and moves the spool in control valve.

The 4-port pilot valves for front attachment/swing and for travel are standard.

The 2-port pilot valve is for counterweight (optional) and for auxiliary (optional).

 **NOTE:** As for the pilot valves for front attachment/swing and for travel, the structure of cam to push in the pusher is different and that of pressure-reducing valve is same.

#### • Front Attachment / Swing Pilot Valve

	Port No.	ISO Control Pattern	Hitachi Pattern
Right	1	Bucket Roll-Out	←
	2	Boom Lower	←
	3	Bucket Roll-In	←
	4	Boom Raise	←
Left	1	Right Swing	Arm Roll-In
	2	Arm Roll-Out	Right Swing
	3	Left Swing	Arm Roll-Out
	4	Arm Roll-In	Left Swing

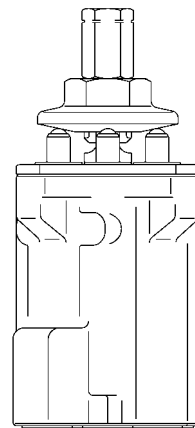

Hydraulic Symbol

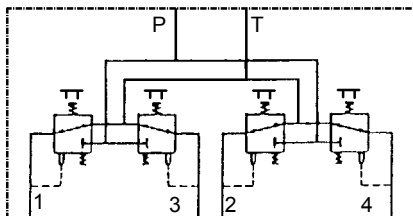

T105-02-07-020

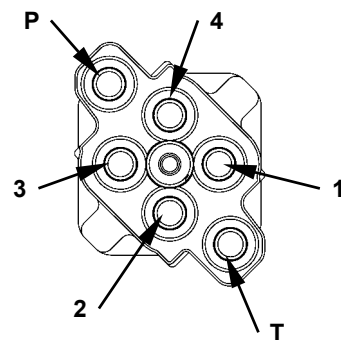

T1V1-03-04-001

## COMPONENT OPERATION / Pilot Valve

• Travel Pilot Valve

Port No.	
1	Travel (Right Reverse)
2	Travel (Right Forward)
3	Travel (Left Forward)
4	Travel (Left Reverse)

Hydraulic Symbol

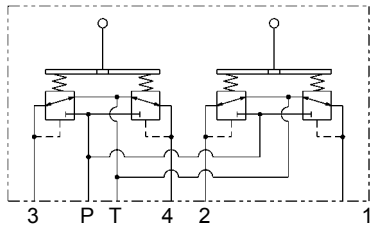

T178-03-04-017

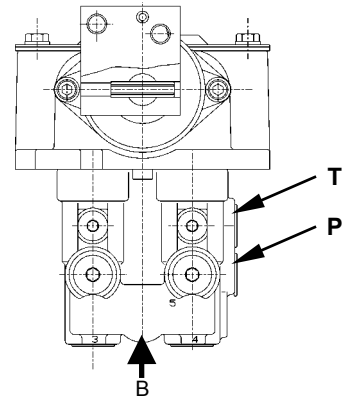

T1M9-03-05-004

View B

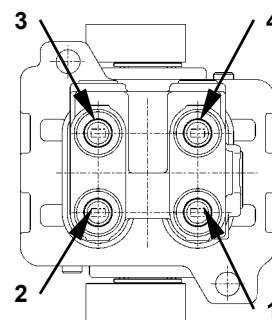

T1M9-03-05-005

• Counterweight (Optional), Auxiliary (Optional) Pilot Valves

	Port No.	
Counterweight	1	Lower
	2	Raise
Auxiliary	1	Open
	2	Close

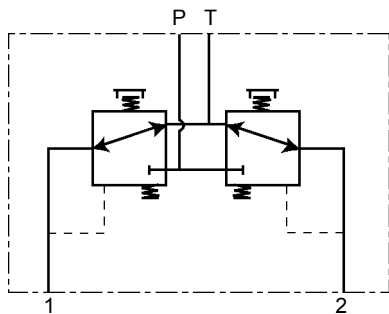

T1CF-03-04-001

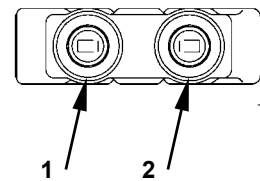
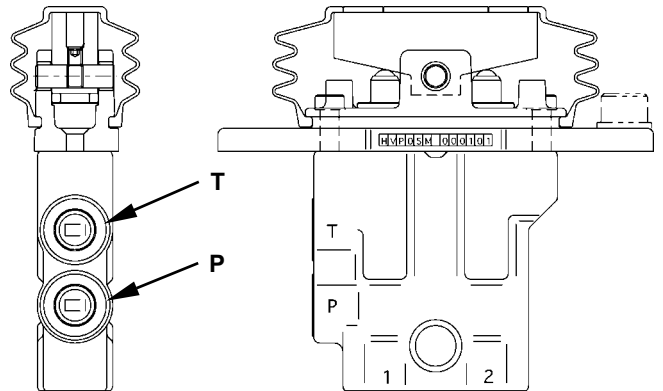

T1CF-03-04-002

## COMPONENT OPERATION / Pilot Valve

---

(Blank)

## COMPONENT OPERATION / Pilot Valve

### OPERATION

- Front Attachment / Swing and Travel Pilot Valves

Spool (6) head comes in contact with the upper surface of spring guide (3) which is kept raised by return spring (5).

#### Neutral (Output Curve: A to B):

1. When in neutral, spool (6) totally blocks pressure oil from port P (the pilot pump). The output port is opened to port T (hydraulic oil tank) through the inner passage in spool (6).
2. Therefore, pressure in the output port is equal to that in port T.
3. When the control lever is slightly tilted, cam (1) is tilted and pusher (2) is downward. Pusher (2) compress return spring (5) along with spring guide (3) together.
4. At this time, as pressure in the output port is equal to that in port T, spool (6) moves downward while keeping the lower surface of spool (6) head in contact with spring guide (3).
5. This status continues until hole (7) on spool (6) is opened to port P.

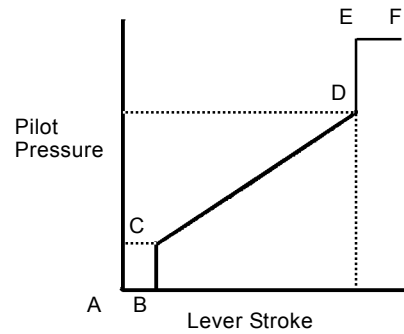

T523-02-05-001

# COMPONENT OPERATION / Pilot Valve

Front Attachment / Swing Pilot Valve

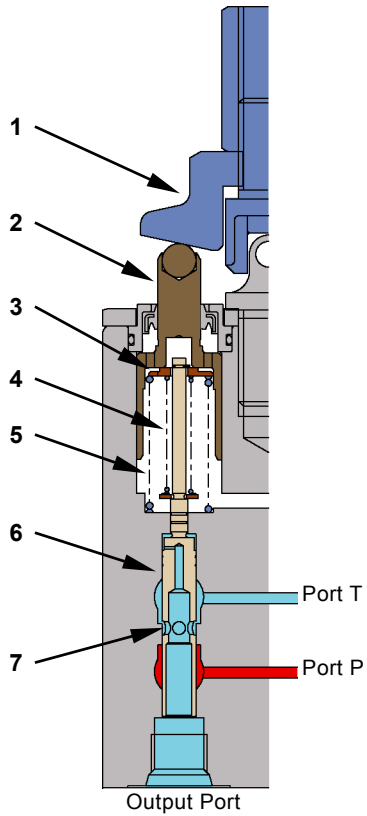

T1V1-03-04-007

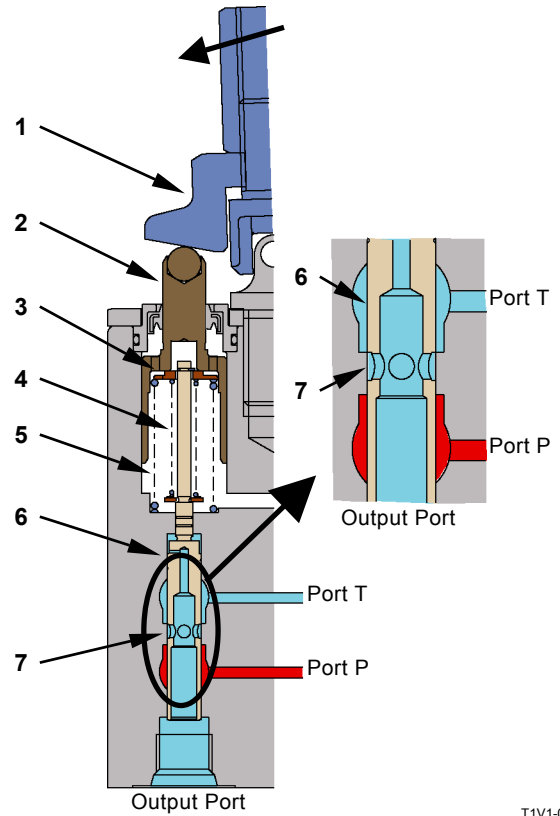

T1V1-03-04-008

Travel Pilot Valve

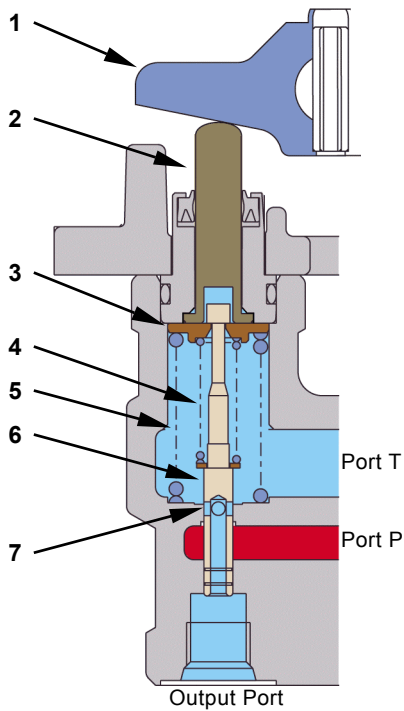

T1V1-03-04-002

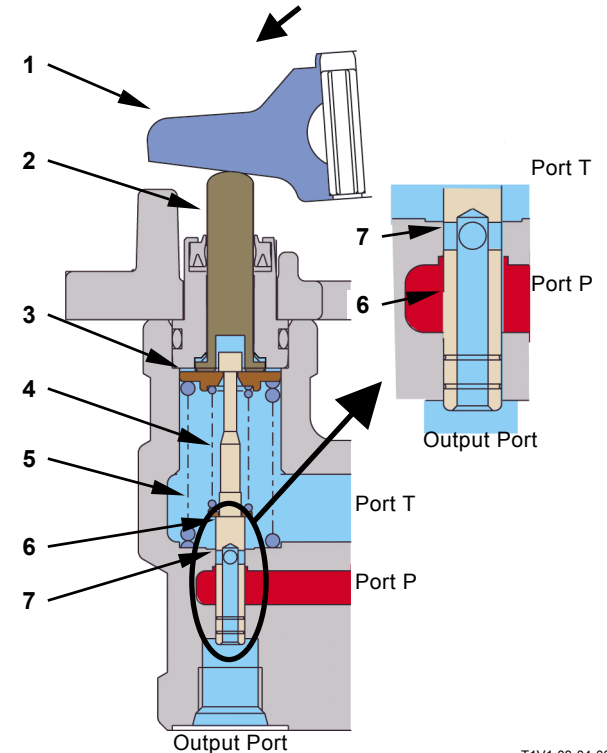

T1V1-03-04-003

1 - Cam  
2 - Pusher

3 - Spring Guide  
4 - Balance Spring

5 - Return Spring  
6 - Spool

7 - Hole



## COMPONENT OPERATION / Pilot Valve

### During Metering or Decompressing (Output Curve: C to D)

1. When the control lever is further tilted in order to move pusher (2) downward more, hole (7) on spool (6) is opened to port P and pressure oil in port P flows into the output port.
2. Pressure in the output port acts on the bottom surface of spool (6) so that spool (6) is pushed upward.
3. Until upward force acting on the bottom surface of spool (6) overcomes the balance spring (4) force, balance spring (4) is not compressed so that spool (6) is not raised and pressure in the output port increases.
4. As pressure in the output port increases, the force to push spool (6) upward increases. When this force overcomes the balance spring (4) force, balance spring (4) is compressed so that spool (6) is moved upward.
5. As spool (6) is moved upward, hole (7) is closed so that pressure oil from port P stops flowing into the output port and pressure in the output port stops increasing.
6. As spool (6) is moved downward and balance spring (4) is compressed, pressure acting on the bottom surface of spool (6) increases until pressure balances with the increasing spring force. This increasing pressure becomes pressure at the output port.

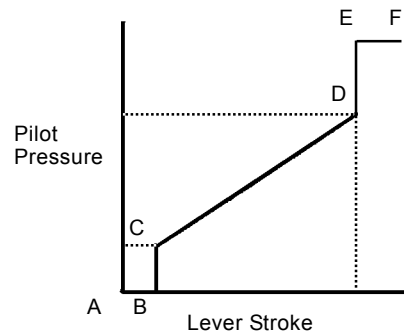

T523-02-05-001

# COMPONENT OPERATION / Pilot Valve

## Front Attachment / Swing Pilot Valve

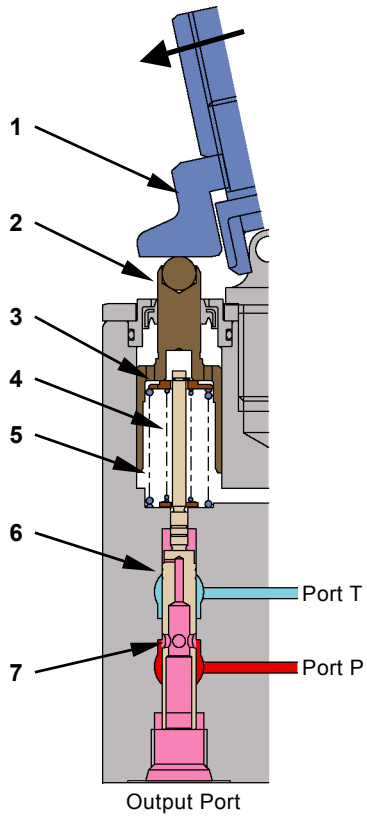

T1V1-03-04-009

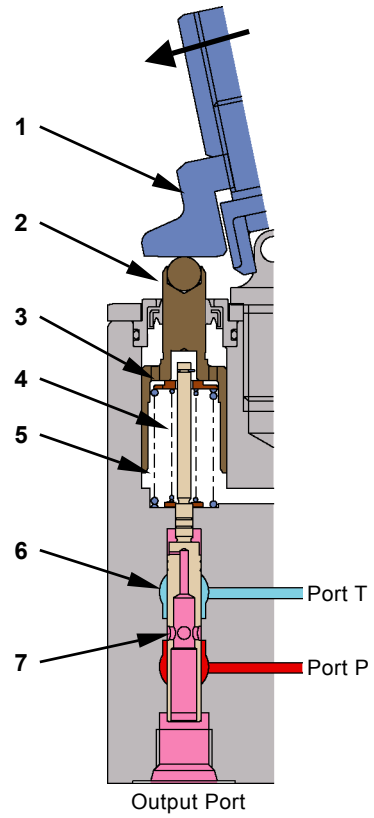

T1V1-03-04-010

## Travel Pilot Valve

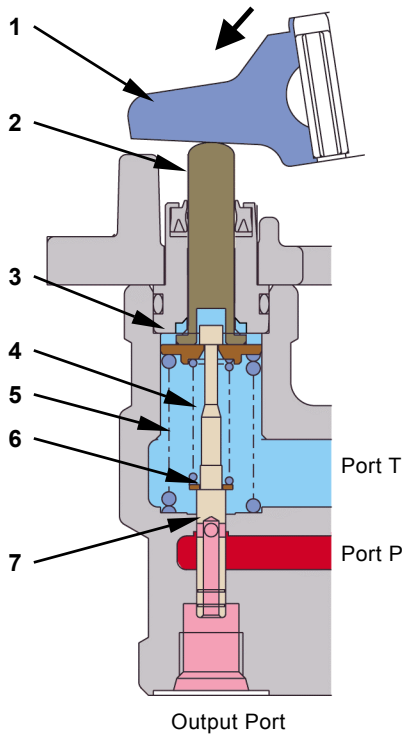

T1V1-03-04-004

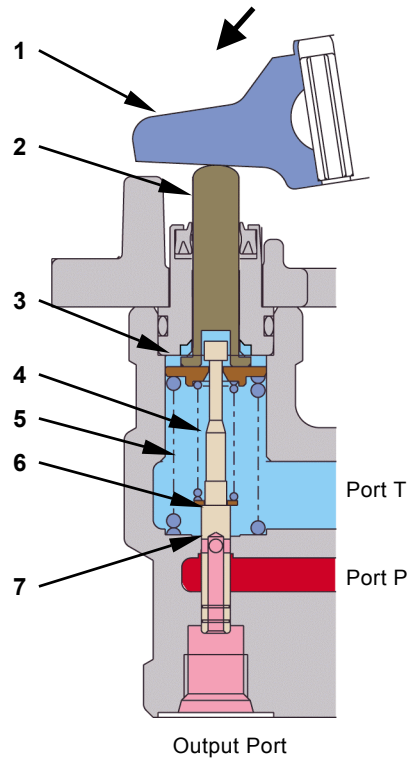

T1V1-03-04-005

1 - Cam  
2 - Pusher

3 - Spring Guide  
4 - Balance Spring

5 - Return Spring  
6 - Spool

7 - Hole

## COMPONENT OPERATION / Pilot Valve

### Full Stroke (Output Curve: E to F)

1. When the control lever is fully stroked, pusher (2) is moved downward until pusher (2) on the front attachment / swing pilot valve comes in contact with the casing shoulder, or cam (1) on the travel pilot valve comes in contact with the casing.
2. At this time, the bottom surface of pusher (2) directly pushes spool (6). Therefore, even if pressure in the output port increases further, hole (7) on spool (6) is kept open.
3. Consequently, pressure in the output port is equal to that in port P.

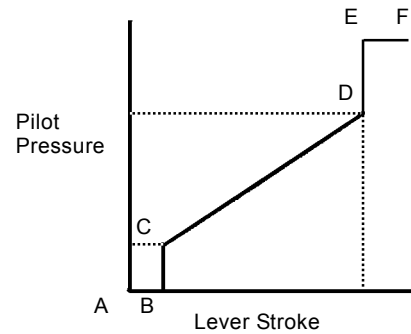

T523-02-05-001

 **NOTE:** Total lever strokes for front attachment and swing controls are determined by stroke dimension (E) of pusher (2). Total lever stroke for travel control is determined by stroke dimension (E) of cam (1).

# COMPONENT OPERATION / Pilot Valve

Front Attachment / Swing Pilot Valve

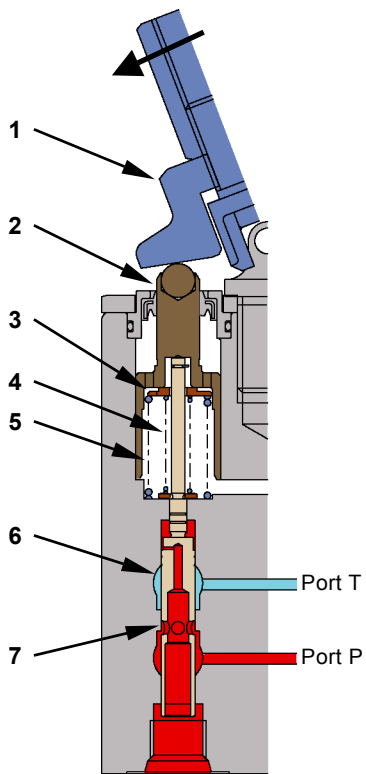

Output Port

T1V1-03-04-011

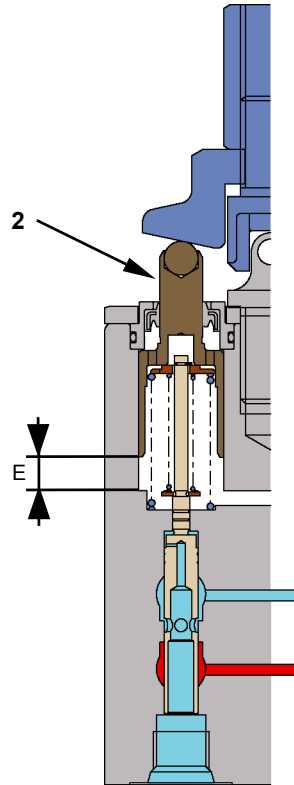

T1V1-03-04-007

Travel Pilot Valve

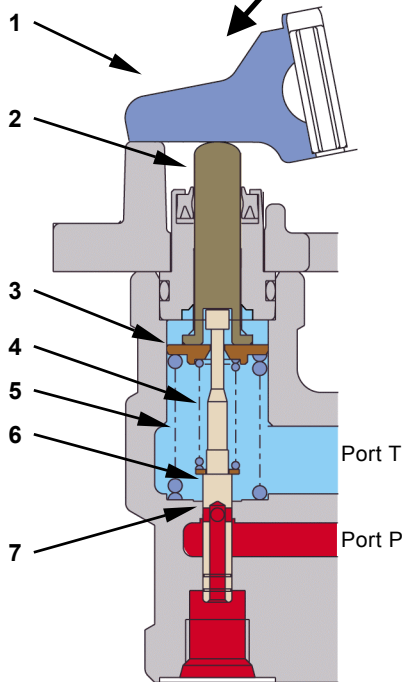

Output Port

T1V1-03-04-006

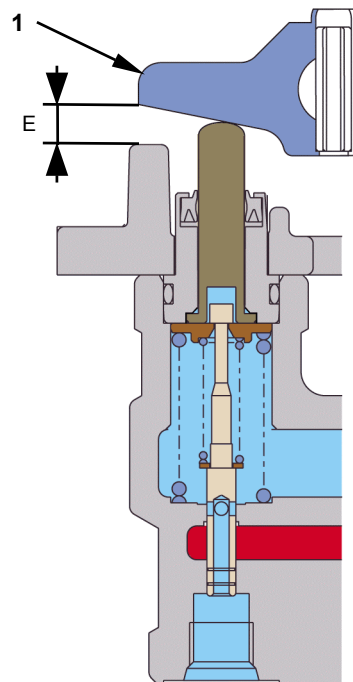

T1V1-03-04-002

1 - Cam  
2 - Pusher

3 - Spring Guide  
4 - Balance Spring

5 - Return Spring  
6 - Spool

7 - Hole

## COMPONENT OPERATION / Pilot Valve

- Counterweight (Optional) / Auxiliary (Optional) Pilot Valves

### In Neutral (Output Curve: A to B)

1. When the control lever is in neutral, spool (7) completely blocks pressure oil from port P.
2. As the output port is connected to port T through the passage in spool (7), pressure in the output port is equal to that in the hydraulic oil tank.
3. When the control lever is slightly tilted, cam (1) is moved and pusher (2) compresses return spring (6) downward with spring guide (4) together.
4. At this time, spool (7) is pushed by balance spring (5) and moved downward until dimension (A) becomes zero (port P is aligned with the hole).
5. During this movement, the output port is connected to port T so that pressure oil is not supplied to the output port.

 **NOTE:** The lever stroke while pressure at dimension (A) becomes zero is play.

### During Metering or Decompressing (Output Curve: C to D)

1. When the control lever is tilted further, the hole on spool (7) is connected to the notch.
2. Pressure oil in port P flows into the output port through the notch and the hole on spool (7), and pressure in the output port increases.
3. Pressure in the output port acts on the bottom surface of spool (7) and spool (7) is moved upward.
4. When the force to move spool (7) upward is smaller than balance spring (5), balance spring (5) is not compressed.
5. Therefore, as port P is kept connected to the output port, pressure in the output port continues to increase.
6. When pressure in the output port increases further, the force to move spool (7) upward increases.
7. When this force becomes larger than balance spring (5), spool (7) compresses balance spring (5) and moves upward.
8. When spool (7) moves upward, the notch is closed. As pressure oil from port P does not flow to the output port, pressure in the output port stop increasing.
9. As spool (7) is moved downward and balance spring (5) is compressed, pressure acting on the bottom surface of spool (7) increases until pressure balances with the increasing spring force. This increasing pressure becomes pressure at the output port.

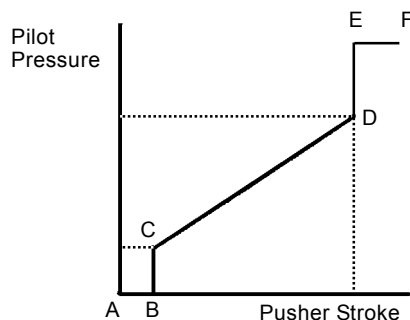

T523-02-05-001

## COMPONENT OPERATION / Pilot Valve

In Neutral (Output Curve: A to B)

During Metering or Decompressing (Output Curve: C to D)

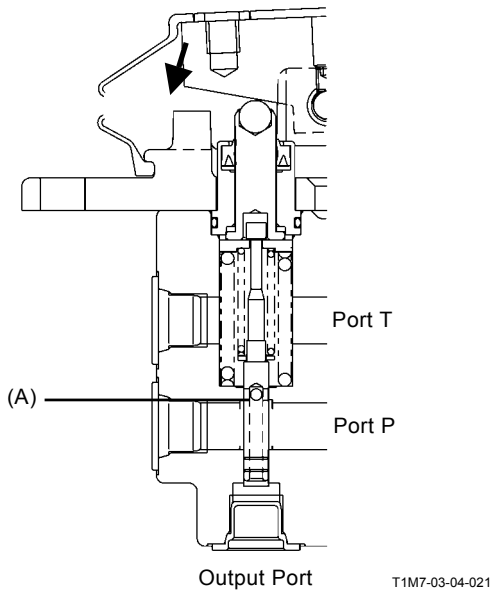
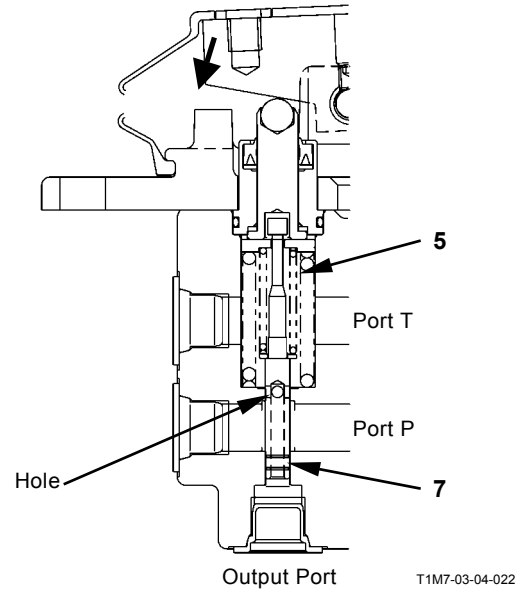
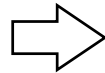
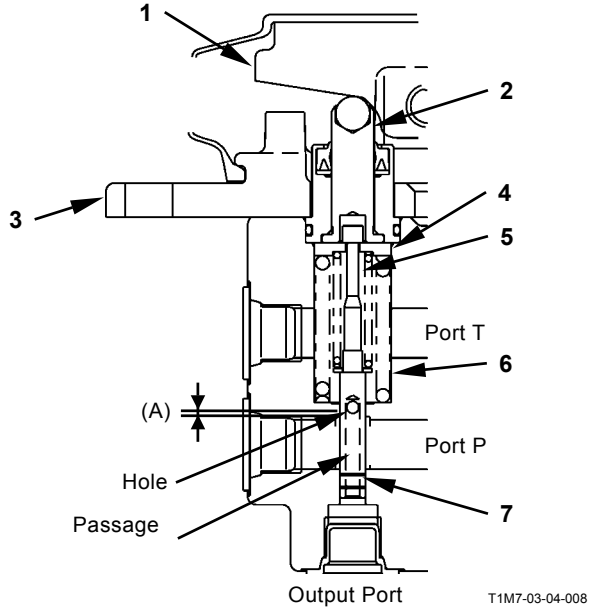

1 - Cam  
2 - Pusher

3 - Plate  
4 - Spring Guide

5 - Balance Spring  
6 - Return Spring

7 - Spool

## COMPONENT OPERATION / Pilot Valve

---

### Full Stroke (Output Curve: E to F)

1. When the control lever is fully stroked, pusher (2) is moved downward until cam (1) comes in contact with the casing.
2. At this time, the bottom surface of pusher (2) directly pushes spool (7). Therefore, even if pressure in the output port increases further, the hole on spool (7) is kept open.
3. Consequently, pressure in the output port is equal to that in port P.

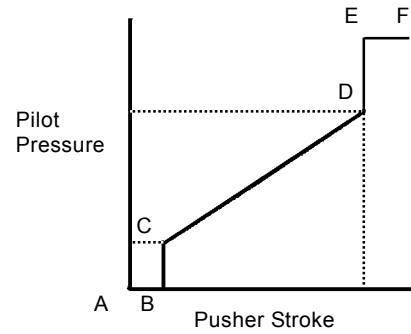

T523-02-05-001

## COMPONENT OPERATION / Pilot Valve

---

Full Stroke (Output Curve: E to F)

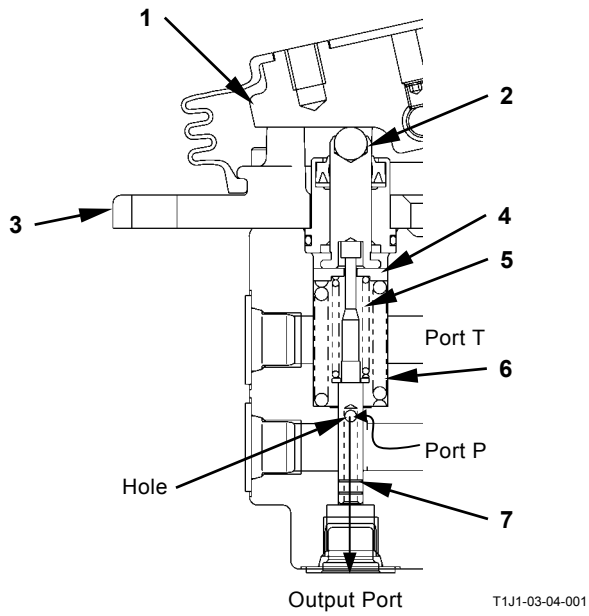

1 - Cam  
2 - Pusher

3 - Plate  
4 - Spring Guide

5 - Balance Spring  
6 - Return Spring

7 - Spool



## COMPONENT OPERATION / Pilot Valve

### SHOCKLESS FUNCTION (ONLY FOR TRAVEL PILOT VALVE)

The travel pilot valve has the damper enabling damping of the speed change shock by the travel lever. The damper is composed of support, gears 1 and 2 and others. Gear 1 is connected with the support. The support is secure to the bracket by using a spring pin. The travel lever and travel pedal are secure to the bracket. Therefore, the support swings transversely around the pin in line with the movement of the travel lever.

#### Operation

1. If the travel lever is released from the hand during traveling, spring force of the return spring returns the travel lever to the neutral position.
2. At this time, gears 1 and 2 inside the damper receive opposing force due to friction.
3. Therefore, as the travel lever gradually returns to the neutral position, the extent of sudden stop at the time of abrupt release of the travel lever is damped down.

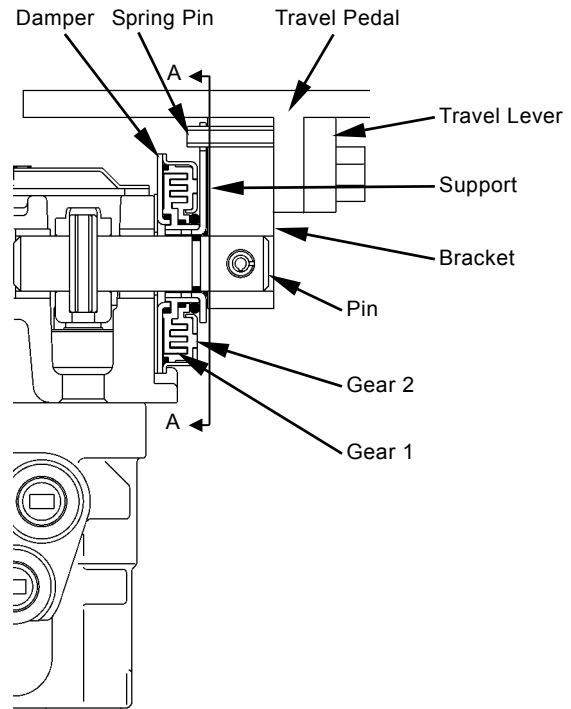

T1M7-03-04-002

#### Section A-A

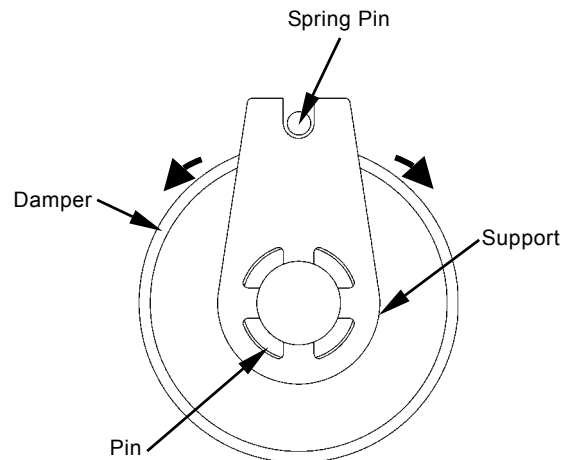

T1M7-03-04-003

## COMPONENT OPERATION / Travel Device

### OUTLINE

The travel device consists of the travel motor, travel reduction gear and travel brake valve. The travel motor is a swash plate type variable displacement axial plunger motor and equipped with the parking brake (with built in a wet-type negative multi-disc brake). The travel motor is driven by pressure oil from the pump and transmits its rotary power to the travel reduction gear.

The travel reduction gear is a three-stage reduction planetary gear type, converts rotary power transmitted from the travel motor to slow large torque, and rotates the sprocket and track. The travel brake valve prevents the travel circuit from being overloaded and prevents the occurrence of cavitation.

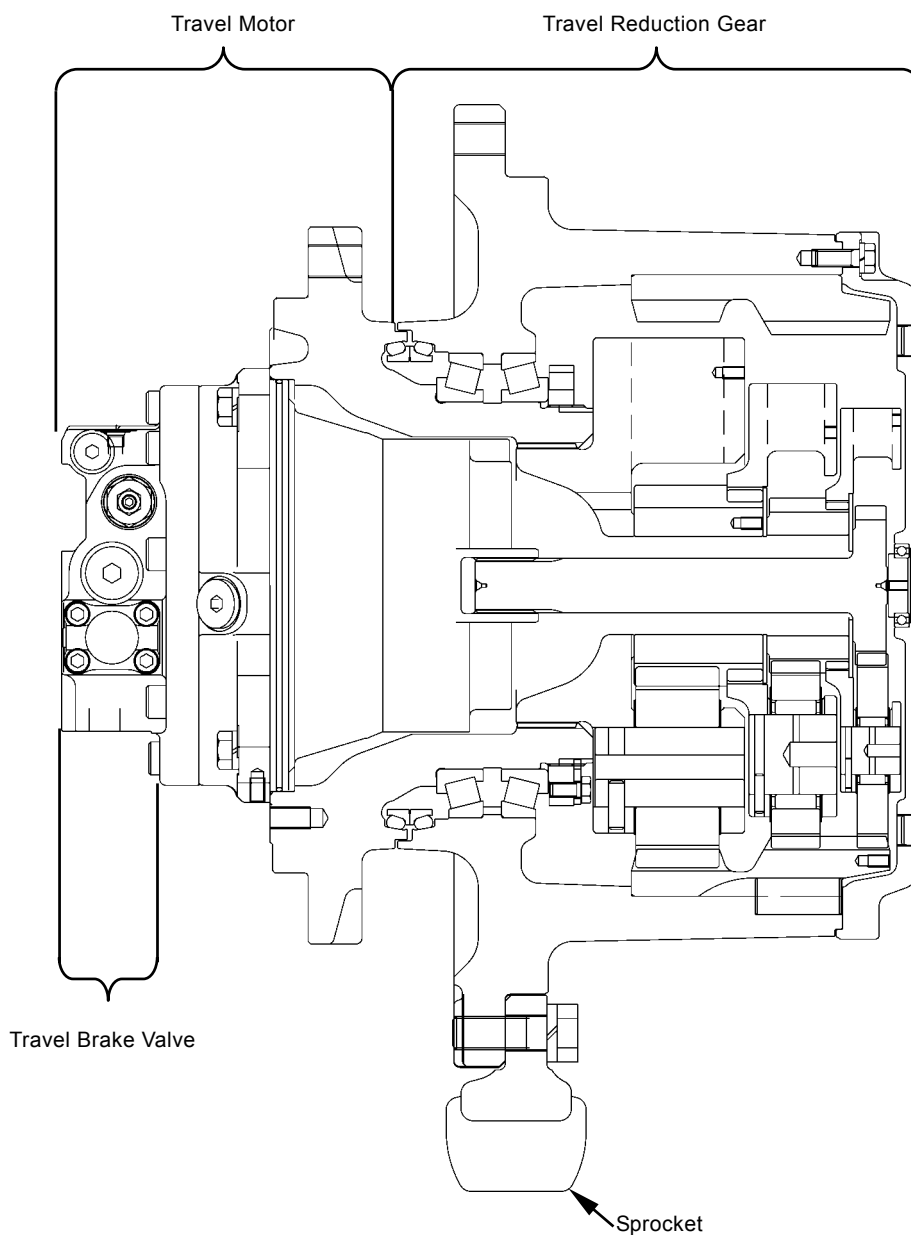

T1J7-03-05-001

## COMPONENT OPERATION / Travel Device

### TRAVEL REDUCTION GEAR

The travel reduction gear is a three-stage reduction planetary gear type.

The travel motor rotates shaft (7). This rotation is transmitted to third stage carrier (2) and ring gear (1) via first stage planetary gear (8), first stage carrier (6), second stage sun gear (5), second stage planetary gear (9), second stage carrier (4), third stage sun gear (3) and third stage planetary gear (10).

Third stage carrier (2) is fixed to by housing (13) and does not rotate. Ring gear (1) and sprocket (11) are bolted to drum (12), and are rotated together.

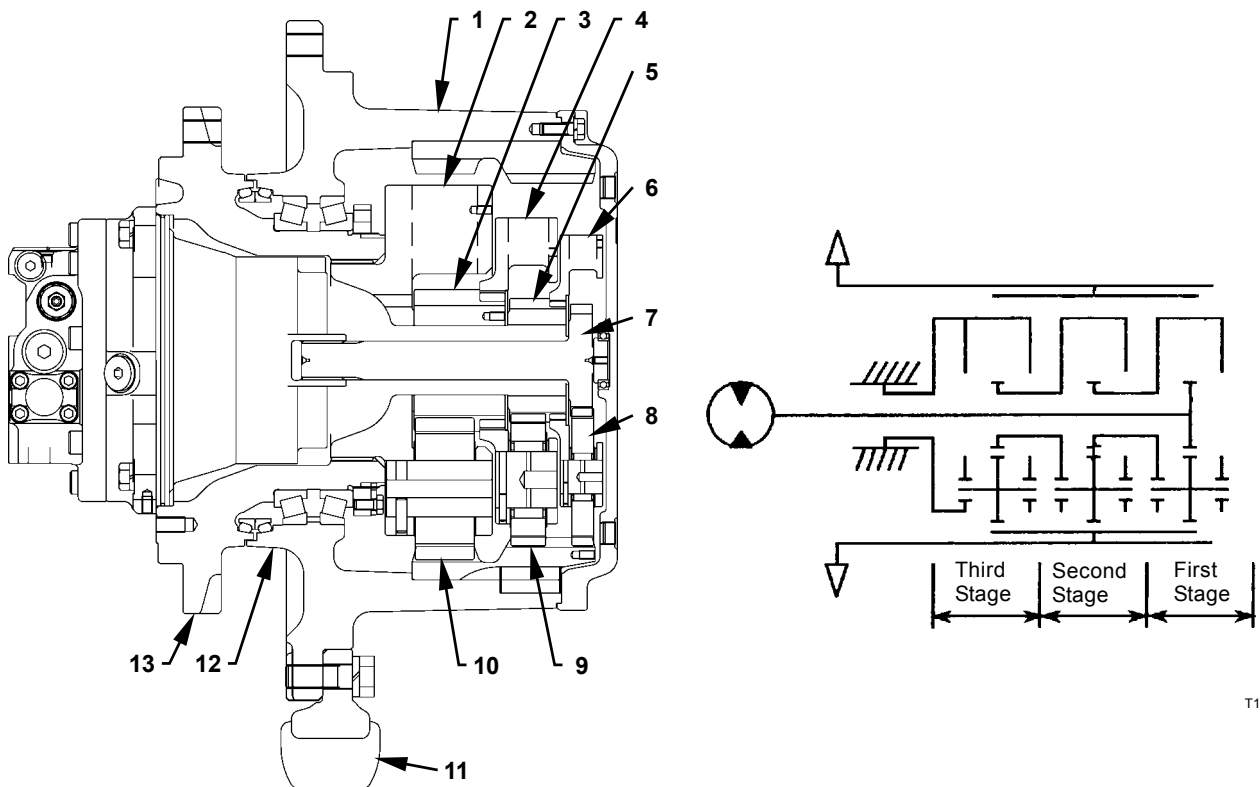

T1J7-03-05-002

T111-03-04-011

- |                          |                           |                                 |               |
|--------------------------|---------------------------|---------------------------------|---------------|
| 1 - Ring Gear            | 5 - Second Stage Sun Gear | 8 - First Stage Planetary Gear  | 11 - Sprocket |
| 2 - Third Stage Carrier  | 6 - First Stage Carrier   | 9 - Second Stage Planetary Gear | 12 - Drum     |
| 3 - Third Stage Sun Gear | 7 - Shaft                 | 10 - Third Stage Planetary Gear | 13 - Housing  |
| 4 - Second Stage Carrier |                           |                                 |               |

## COMPONENT OPERATION / Travel Device

### TRAVEL MOTOR

The travel motor is a swash plate type variable displacement axial plunger motor and equipped with parking brake (3) (with built in a wet-type negative multi-disc brake). The travel motor consists of swash plate (7), rotor (16), plunger (4) with the shoe, valve plate (1), output shaft (11), tilt piston (9) and casing (8).

Four tilt pistons (9) shift the swash angle of swash plate (7) due to a fulcrum as ball (13). Rotor (16) sticks on valve plate (1) due to the spring (14) force.

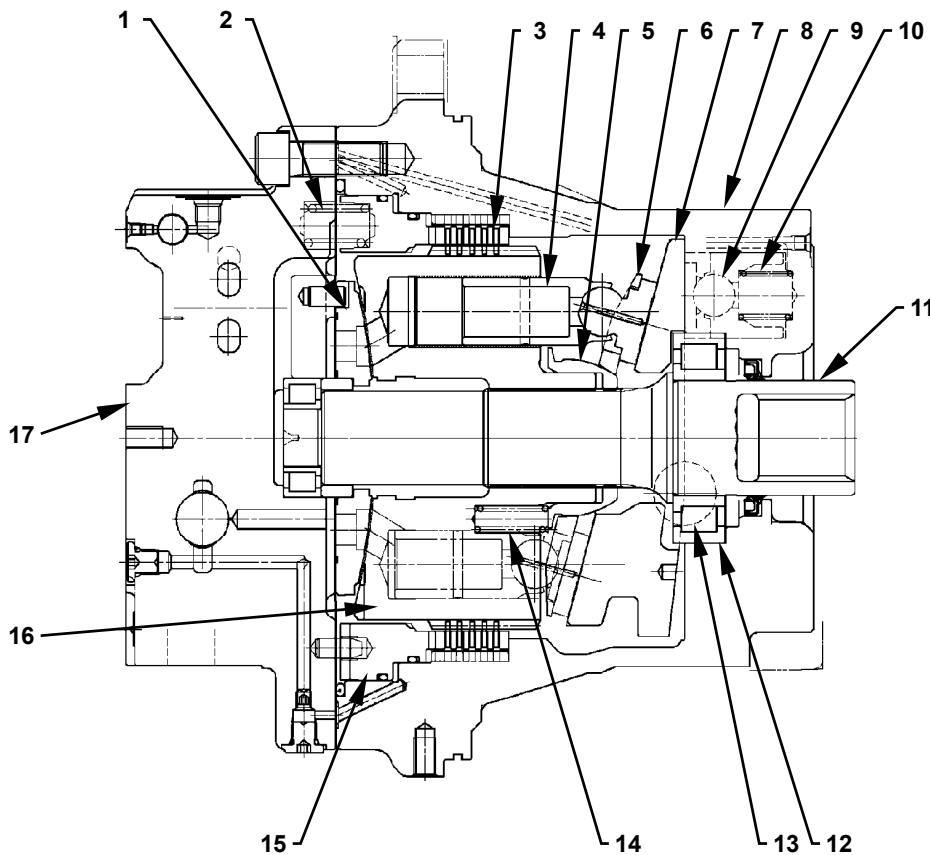

T1JB-03-05-003

- |                   |                    |                     |                   |
|-------------------|--------------------|---------------------|-------------------|
| 1 - Valve Plate   | 6 - Retainer Plate | 10 - Spring         | 14 - Spring       |
| 2 - Spring        | 7 - Swash Plate    | 11 - Output Shaft   | 15 - Brake Piston |
| 3 - Parking Brake | 8 - Casing         | 12 - Roller Bearing | 16 - Rotor        |
| 4 - Plunger       | 9 - Tilt Piston    | 13 - Ball           | 17 - Valve Cover  |
| 5 - Holder        |                    |                     |                   |

## COMPONENT OPERATION / Travel Device

Pressure oil in valve plate (1) flows to port A, enters into one side in rotor (2), and pushes plunger (3). This force and inclination of swash plate (5) make shoe (4) slide on swash plate (5) in order to rotate rotor (2) and output shaft (6).

As rotor (2) rotates, when plungers (3) reach port B, oil is routed to the hydraulic oil tank. Whether pressure oil is supplied to port A or port B determines the travel direction.

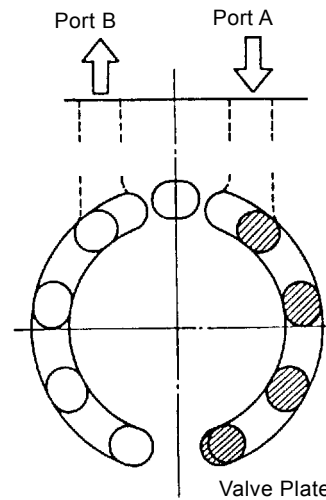
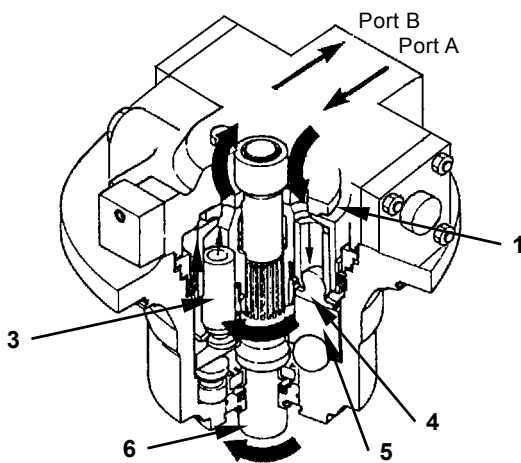

T183-03-05-009

1 - Valve Plate  
2 - Rotor

3 - Plunger  
4 - Shoe

5 - Swash Plate

6 - Output Shaft

## COMPONENT OPERATION / Travel Device

### TRAVEL BRAKE VALVE

The travel brake valve is located on the travel motor head and consists of the following valves.

- **Overload Relief Valve:**  
Prevents the occurrence of overload and surge pressure in the motor circuit.
- **Counterbalance Valve:**  
Makes starting and stopping travel operations smooth and prevents the machine from running away while descending slopes.
- **Check Valve:**  
Assists the counterbalance valve operation and prevents cavitation in the motor circuit.
- **Travel Mode Selection Valve:**  
Controls the tilt piston when selecting travel mode.

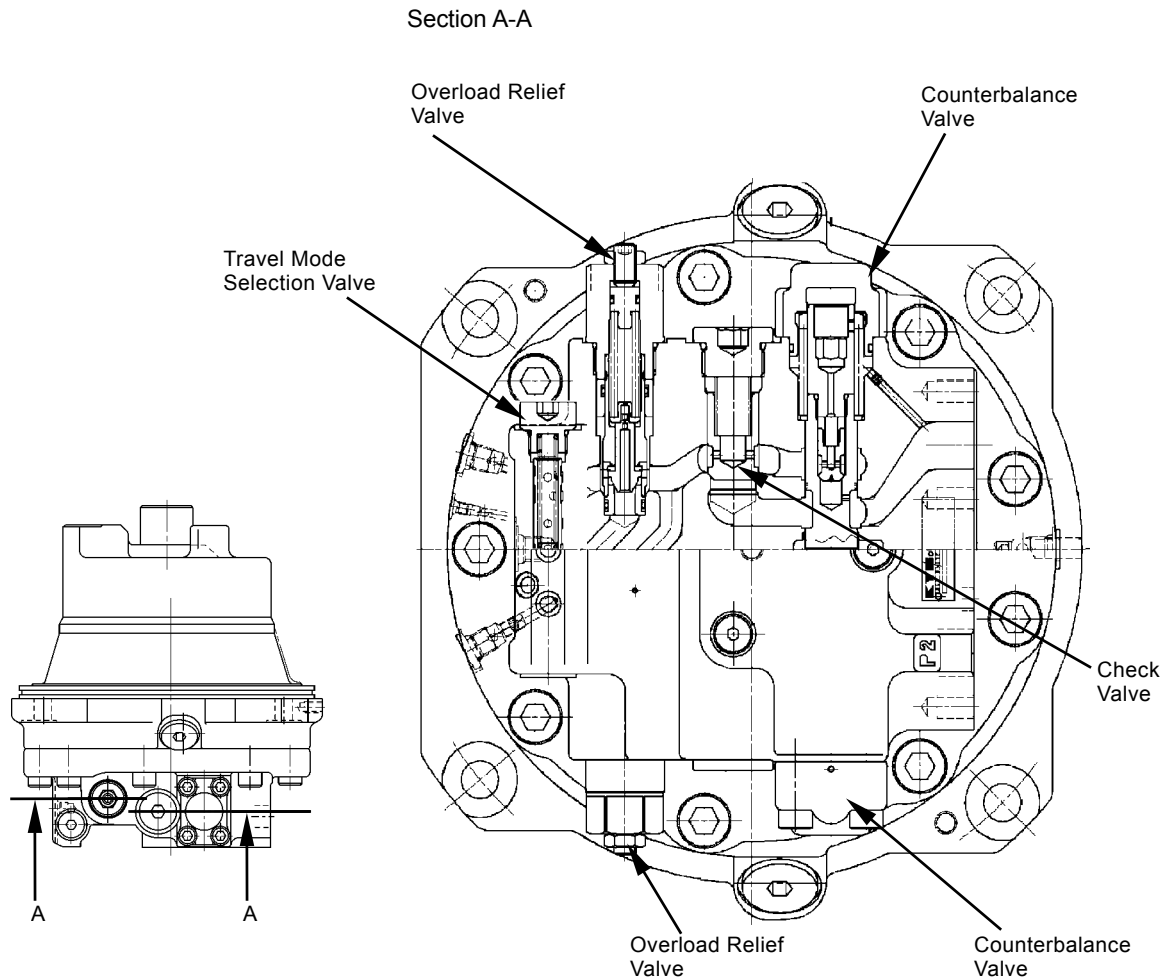

T1J1-03-05-004

## COMPONENT OPERATION / Travel Device

---

### Counterbalance Valve, Check Valve

#### While Traveling:

1. When pressure oil from the control valve flows to port P1, pressure oil flows unseats the check valve, flows to port BM and the travel motor.
2. On the other hand, return oil from the travel motor is routed to port AM. However, return oil is blocked by the spool in counterbalance valve.
3. When pressure in port P1 increases further, pressure oil from port P1 pushes to open the check valve in spool through oil passage F in spool, and flows to chamber G. Pressure oil from port P1 flows to chamber G through the orifice and orifice A in the spool.
4. Therefore, the spool moves to the lower. At this time, pressure oil from port P1 flows to port A and is supplied to the parking brake, so that the parking brake is released.
5. Return oil from the travel motor flows to port P2 through notch H on the spool. Then, pressure oil is allowed to flow so that the travel motor starts rotating.
6. When the travel lever is returned to neutral, oil in ports P1 and P2 flows to the hydraulic oil tank through the control valve.
7. Oil in chamber G flows to port P1 through the orifice and pressure in chamber G is reduced.
8. Therefore, the spool is returned to the original position by spring force and blocks the oil passage, so that the travel motor rotation is stopped.

#### While Descending:

1. While descending a slope, the travel motor is forcibly rotated by the machine weight so that the motor operates like a pump.
2. If the travel motor draws oil, oil pressure in port P1 and chamber G decrease and the spool moves upward, so that return oil from the travel motor is restricted. Therefore, pressure in port AM increases and brakes the travel motor.
3. Once return oil from the travel motor is restricted, pressure in port P1 increases again and moves the spool downward.
4. As this operation (hydraulic braking operation) is repeated, the machine is prevented from running away.

# COMPONENT OPERATION / Travel Device

While Traveling:

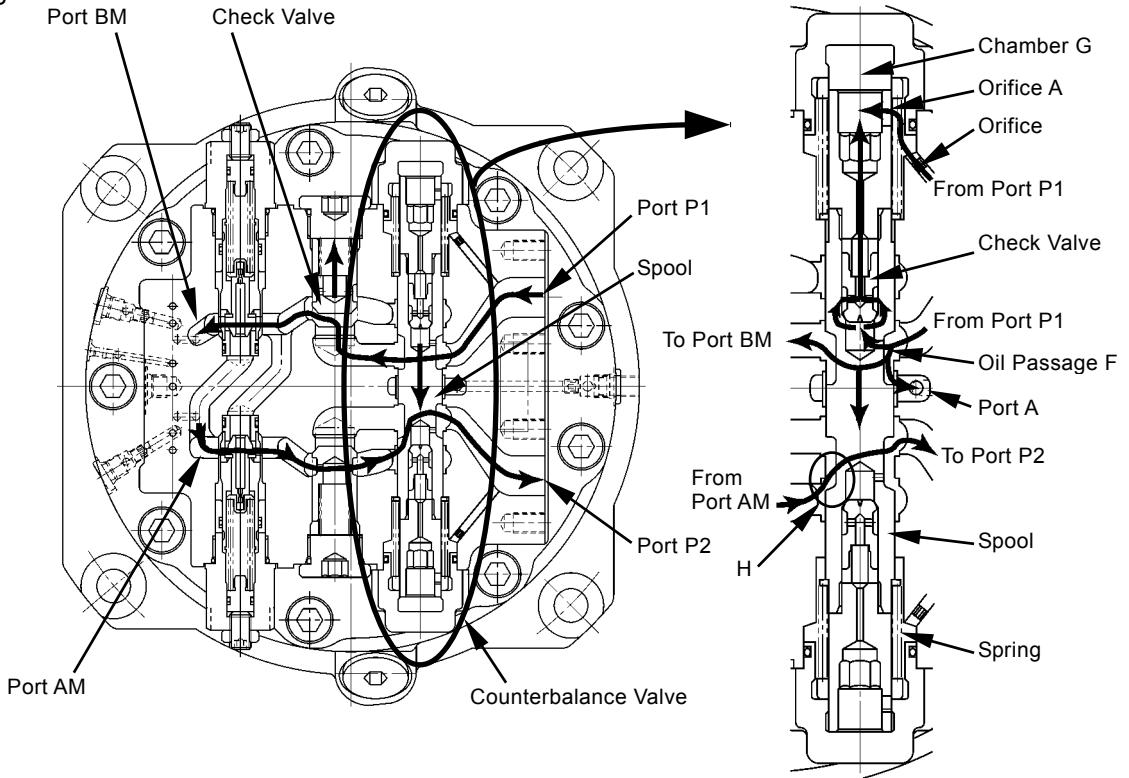

T1J1-03-05-005

While Descending:

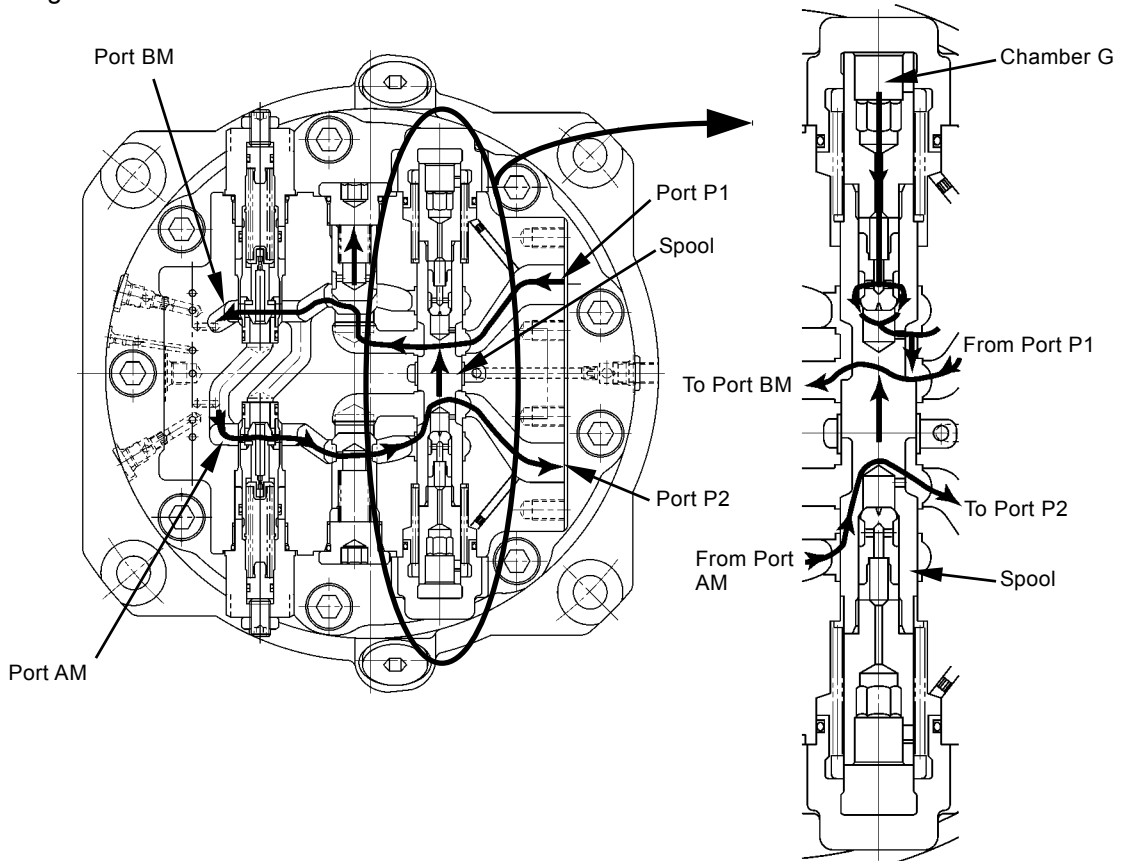

T1J1-03-05-006



## COMPONENT OPERATION / Travel Device

---

### Overload Relief Valve

Circuit Protection Operation:

1. When pressure in the circuit increases over the set-pressure of overload relief valve, the poppet is opened and high pressure oil relieves to the low pressure side, so that the travel motor is protected from being overloaded.
2. In addition, the overload relief valve relieves the shock loads developed due to inertia force when stopping the travel motor.

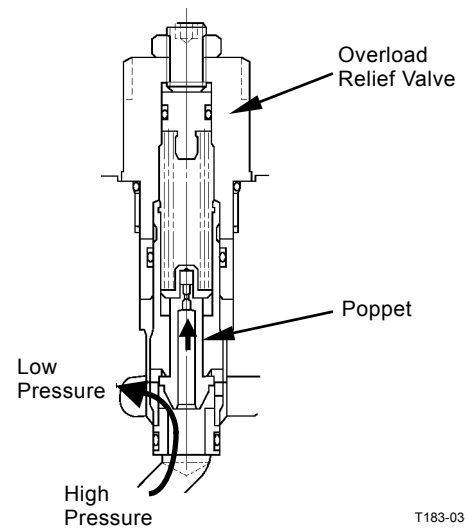

T183-03-05-011

## COMPONENT OPERATION / Travel Device

---

(Blank)

## COMPONENT OPERATION / Travel Device

### Travel Mode Selection Valve

The travel speed mode changes as the displacement angle of swash plate (3) is changed by tilt piston (5).

#### Slow Speed (Maximum Displacement Angle)

1. Spool (8) in travel mode selection valve (1) is held in neutral by the spring (2) force.
2. As pressure oil from the control valve is blocked by spool (8) through the counterbalance valve. The circuit to tilt pistons (5) is opened to the hydraulic oil tank.
3. Therefore, as the displacement angle of swash plate (3) is fixed to the larger side, the plunger (6) stroke becomes maximum. As amount of oil required to rotate the travel motor becomes maximum, the travel motor rotates at low speed. (Refer to the Control System Group/SYSTEM as for the control circuit.)

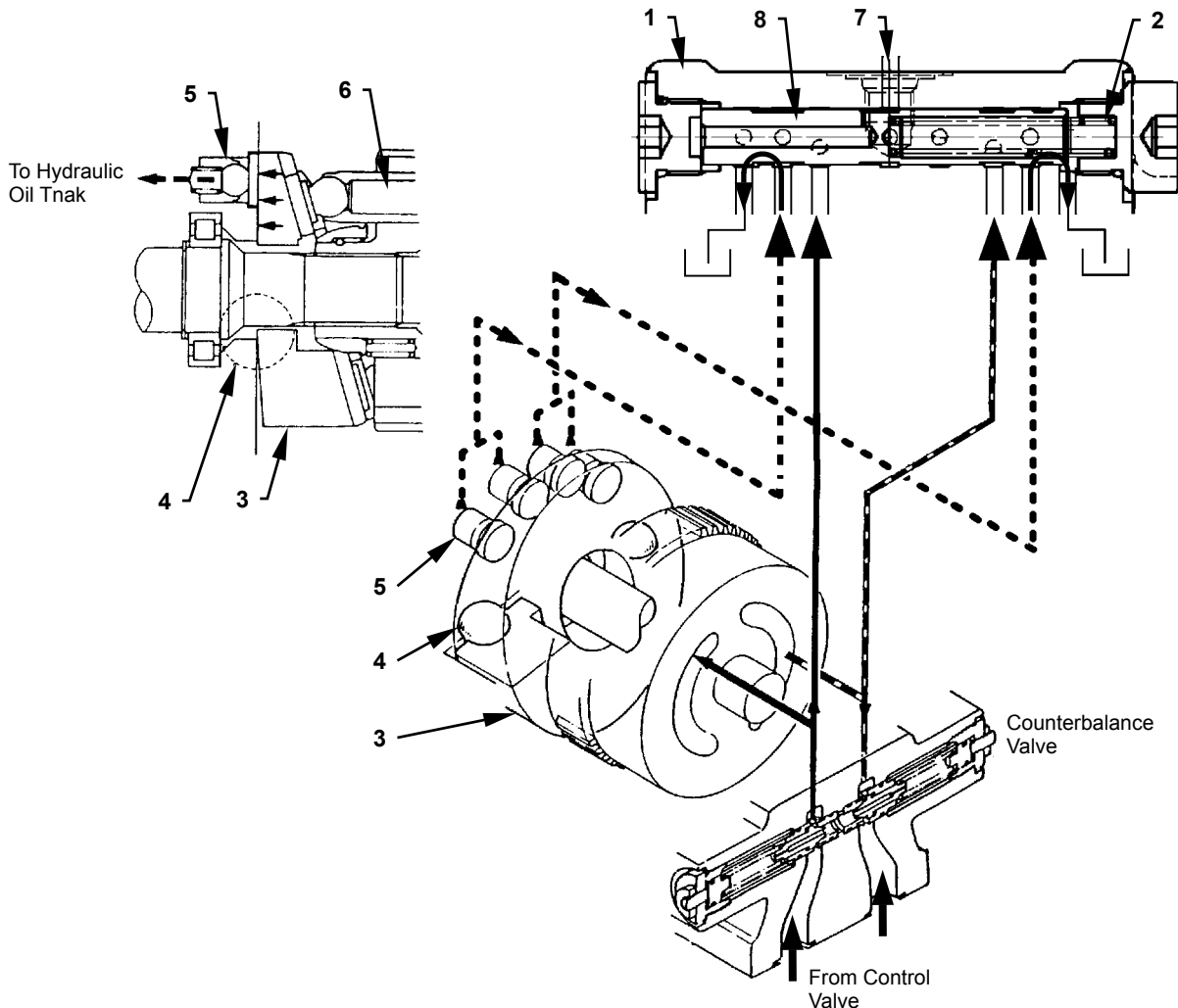

T1J1-03-05-007

- |                                 |                 |                 |  |
|---------------------------------|-----------------|-----------------|--|
| 1 - Travel Mode Selection Valve | 3 - Swash Plate | 5 - Tilt Piston | 7 - Pilot Pressure (From Solenoid Valve Unit (SI)) |
| 2 - Spring                      | 4 - Ball        | 6 - Plunger     | 8 - Spool  |

## COMPONENT OPERATION / Travel Device

### Fast Speed (Minimum Displacement Angle)

1. When pilot pressure (7) from solenoid valve unit (SI) is supplied to travel mode selection valve (1), pilot pressure (7) is supplied to chamber A (10) through orifice (9) in spool (8) and moves spool (8) to the right.
2. As spool (8) moves, pressure oil from the control valve acts on tilt pistons (5) through the counter balance valve and spool (8).
3. Therefore, tilt pistons (5) pushes swash plate (3) and the displacement angle is reduced to the minimum.
4. Consequently, the travel motor rotates at high speed.  
(Refer to the Control System Group/SYSTEM as for the control circuit.)

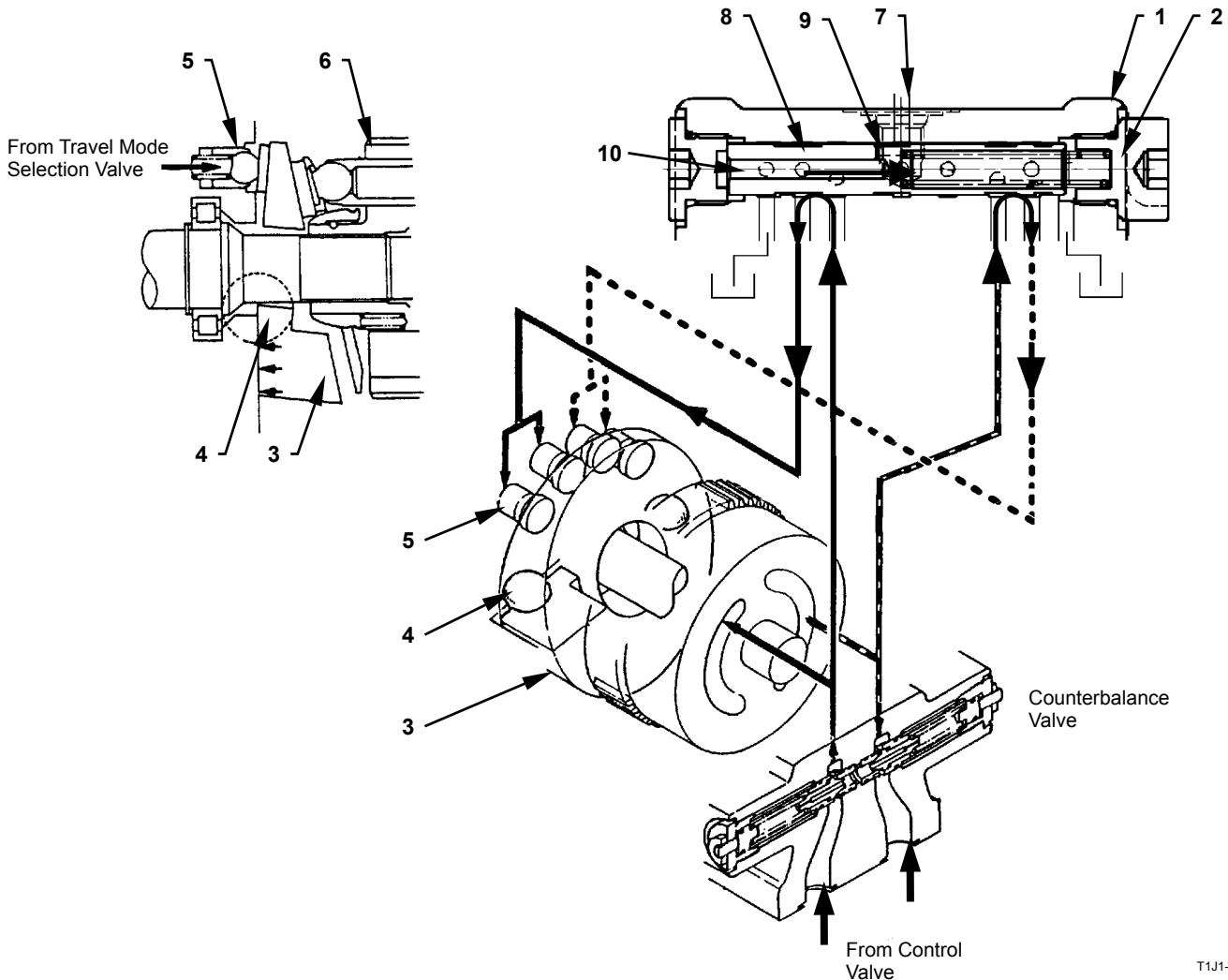

T1J1-03-05-008

- |                                 |                 |  |                |
|---------------------------------|-----------------|--|----------------|
| 1 - Travel Mode Selection Valve | 4 - Ball        | 7 - Pilot Pressure (From Solenoid Valve Unit (SI)) | 9 - Orifice    |
| 2 - Spring                      | 5 - Tilt Piston | 8 - Spool  | 10 - Chamber A |
| 3 - Swash Plate                 | 6 - Plunger     |  |                |

## COMPONENT OPERATION / Travel Device

### PARKING BRAKE

The parking brake is a negative-type brake released when pilot pressure oil is applied to piston chamber (2). The parking brake is automatically applied except during travel operation.

Friction plate (5) is connected to rotor (7) and plate (4) is connected to casing (6) via spline couplings respectively.

When spring (1) pushes piston (3) and friction plate (5) comes into contact with plate (4), the parking brake is applied.

(Refer to the pilot circuit in the Hydraulic Circuit Group / SYSTEM as for pilot oil flow.)

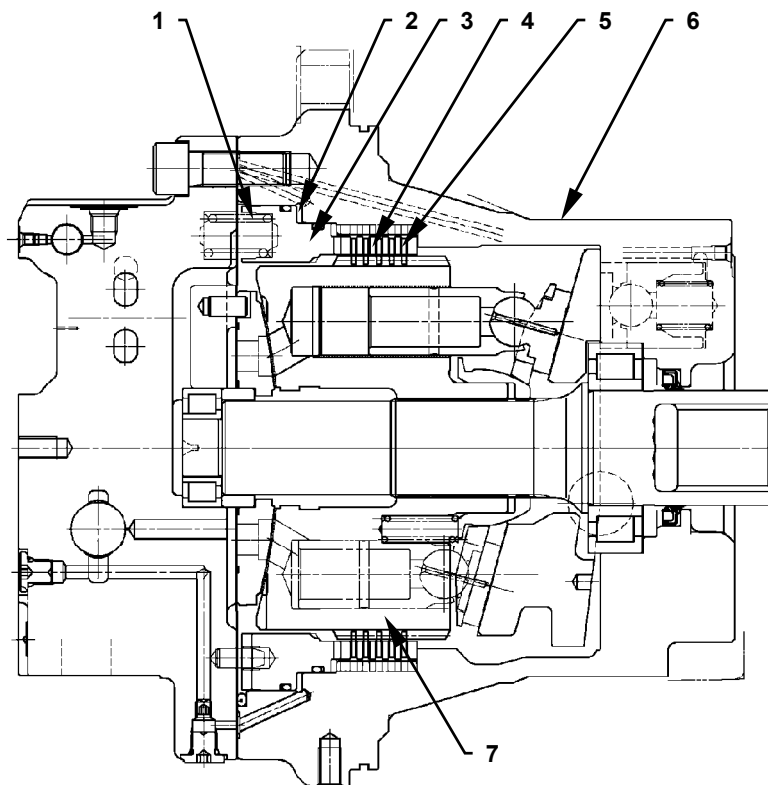

T1JB-03-05-003

1 - Spring  
2 - Piston Chamber

3 - Piston  
4 - Plate

5 - Friction Plate  
6 - Casing

7 - Rotor

## COMPONENT OPERATION / Travel Device

### When Brake is Applied

When the travel lever is in the neutral position, the friction plate and plate come in contact tightly, so that the parking brake is applied. At this time, oil in the piston chamber returns to the hydraulic oil tank.

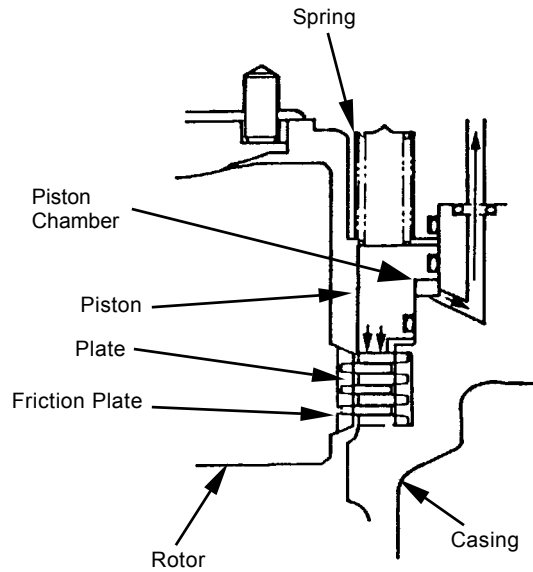

T111-03-04-007

### When Brake is Released

When the travel lever is operated, pilot pressure oil flows to the piston chamber and acts on the piston. Therefore, the piston is pushed and moves upward. Consequently, the friction plate is separated from the plate and the parking brake is released.

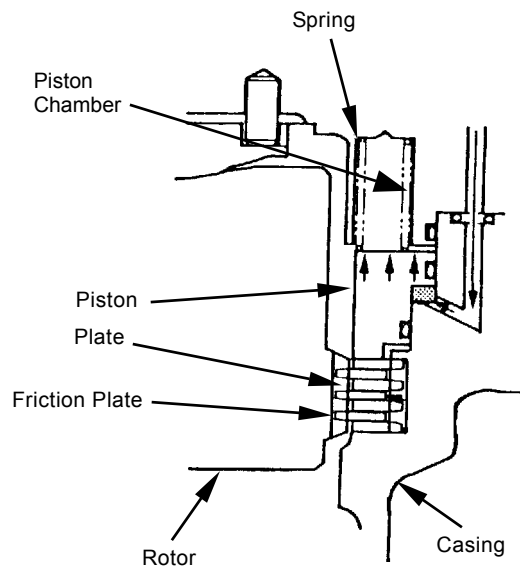

T111-03-04-008

## COMPONENT OPERATION / Travel Device

---

(Blank)

# COMPONENT OPERATION / Signal Control Valve

## OUTLINE

The signal control valve is provided in the pilot circuit between the pilot valve and control valve, and controls pilot signal pressure to regulate the pumps and various kinds of valves.

The major components of signal control valve are shuttle valve, shockless valve, pump 1 flow rate control valve, pump 2 flow rate control valve, flow combiner valve spool, bucket flow rate control valve spool, swing parking brake release spool and arm 1 flow rate control valve spool.

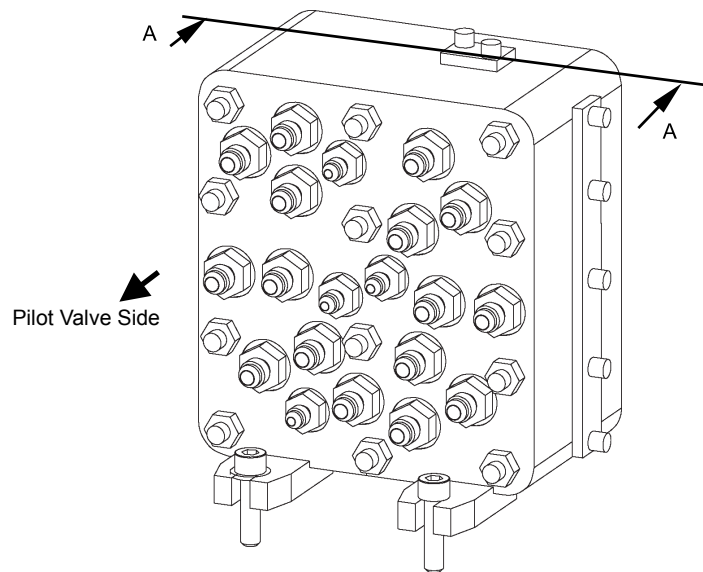

T178-03-06-016

Cross Section A-A

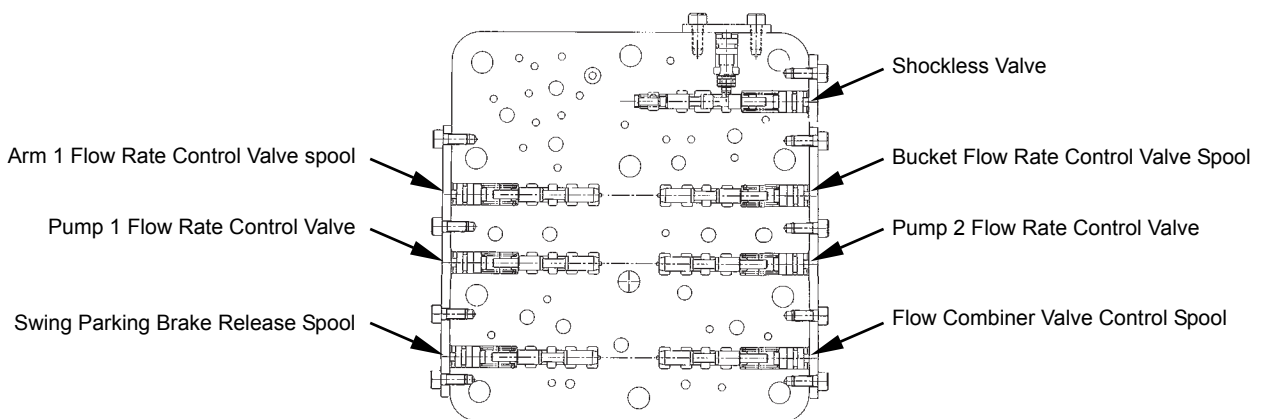

T178-03-06-002



## COMPONENT OPERATION / Signal Control Valve

### PILOT PORT

Pilot Valve Side

Port Name	Connecting to	Remark
Port A	Right Pilot Valve	Boom Raise Pilot Pressure
Port B	Right Pilot Valve	Boom Lower Pilot Pressure
Port C	Left Pilot Valve	Arm Roll-Out Pilot Pressure
Port D	Left Pilot Valve	Arm Roll-In Pilot Pressure
Port E	Left Pilot Valve	Left Swing Pilot Pressure
Port F	Left Pilot Valve	Right Swing Pilot Pressure
Port G	Right Pilot Valve	Bucket Roll-In Pilot Pressure
Port H	Right Pilot Valve	Bucket Roll-Out Pilot Pressure
Port I	Travel Pilot Valve	Left Travel Forward Pilot Pressure
Port J	Travel Pilot Valve	Left Travel Reverse Pilot Pressure
Port K	Travel Pilot Valve	Right Travel Forward Pilot Pressure
Port L	Travel Pilot Valve	Right Travel Reverse Pilot Pressure
Port M	Auxiliary Pilot Valve	Auxiliary Open Pilot Pressure
Port N	Auxiliary Pilot Valve	Auxiliary Close Pilot Pressure
Port SA	Pump 1 Regulator	Pump 1 Control Pressure
Port SB	Pump 2 Regulator	Pump 2 Control Pressure
Port PI	Pilot Shut-Off Valve	Primary Pilot Pressure
Port PH	-	Plug
Port SH	Swing Parking Brake	Brake Release Pressure
Port DF	Hydraulic Oil Tank	Returning to Hydraulic Oil Tank

# COMPONENT OPERATION / Signal Control Valve

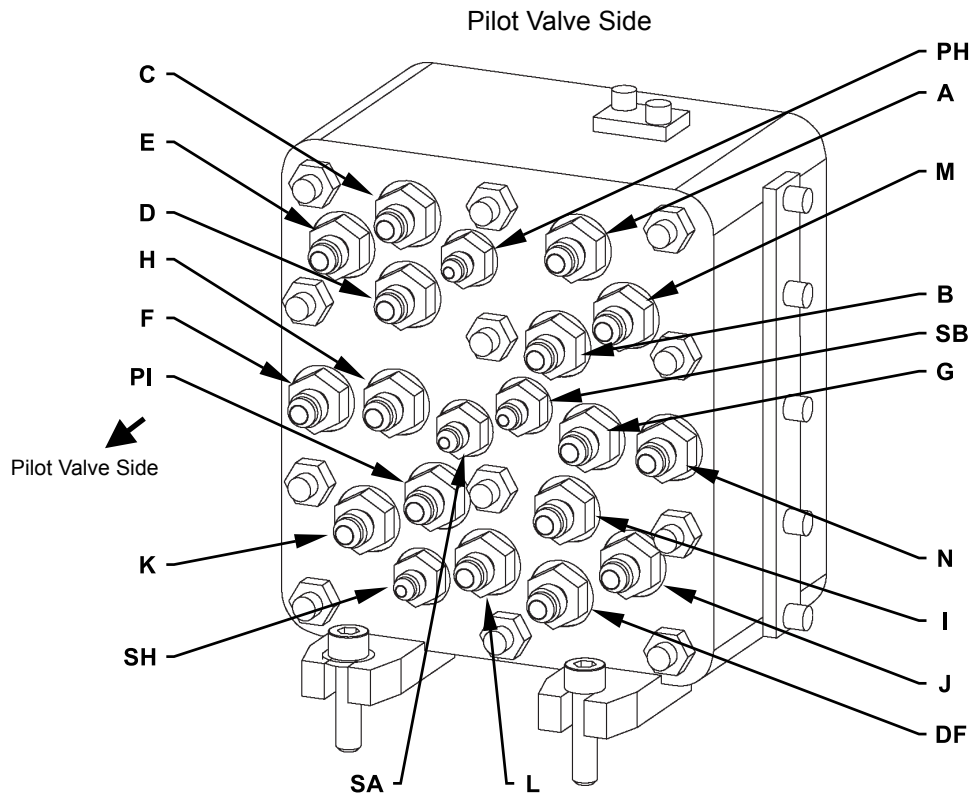

T178-03-06-016

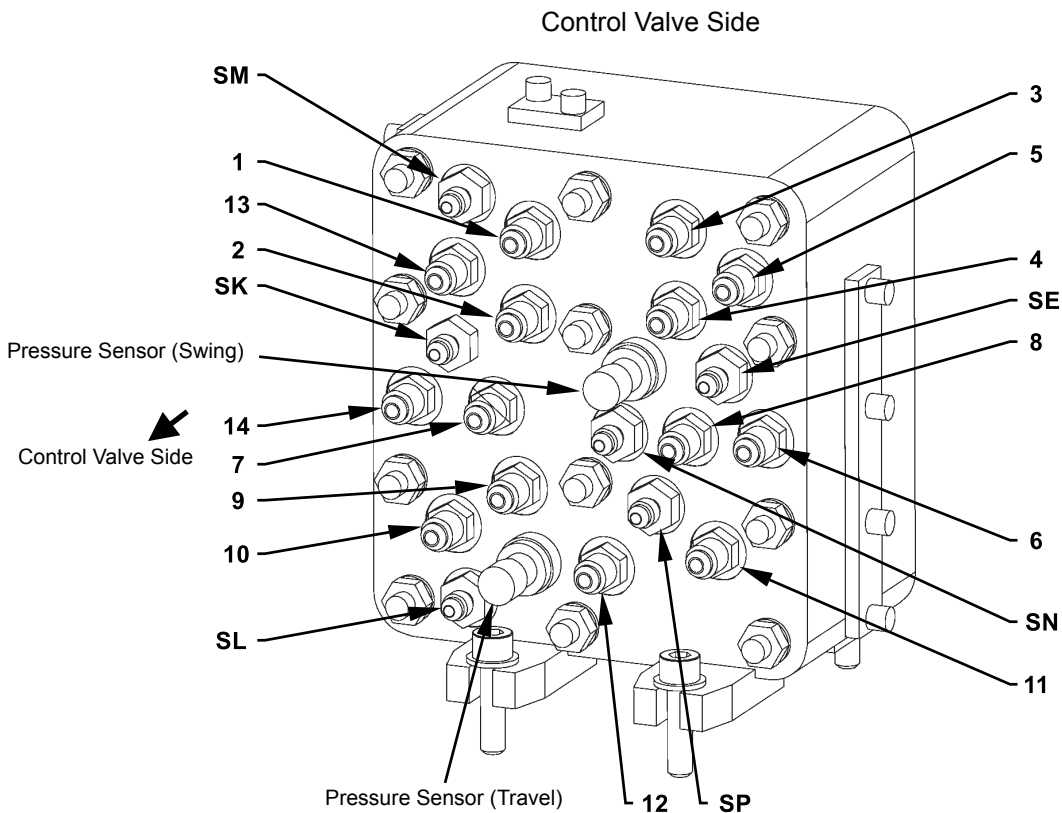

T178-03-06-015

## COMPONENT OPERATION / Signal Control Valve

### Control Valve Side

Port Name	Connecting to	Remark
Port 1	Control Valve	Boom Raise Pilot Pressure
Port 2	Control Valve	Boom Lower Pilot Pressure
Port 3	Control Valve	Arm Roll-Out Pilot Pressure
Port 4	Control Valve	Arm Roll-In Pilot Pressure
Port 5	Control Valve	Left Swing Pilot Pressure
Port 6	Control Valve	Right Swing Pilot Pressure
Port 7	Control Valve	Bucket Roll-In Pilot Pressure
Port 8	Control Valve	Bucket Roll-Out Pilot Pressure
Port 9	Control Valve	Left Travel Forward Pilot Pressure
Port 10	Control Valve	Left Travel Reverse Pilot Pressure
Port 11	Control Valve	Right Travel Forward Pilot Pressure
Port 12	Control Valve	Right Travel Reverse Pilot Pressure
Port 13	Control Valve	Auxiliary Open Pilot Pressure
Port 14	Control Valve	Auxiliary Close Pilot Pressure
Port SE	Control Valve	Arm 1 Flow Rate Control Valve Control Pressure
Port SM	Hydraulic Oil Tank	Returning to Hydraulic Oil Tank
Port SN	-	Plug
Port SP	Hydraulic Oil Tank	Returning to Hydraulic Oil Tank
Port SL	Control Valve	Flow Combiner Valve Control Pressure
Port SK	Control Valve	Bucket Flow Rate Control Valve Control Pressure

### 2-Piece Boom Specification Machine

Port SP	Positioning Pilot Valve	Secondary Pilot Pressure
---------	-------------------------	--------------------------

### Machine with Front Attachment (Secondary Crushers 1 to 5 and Hydraulic Crushers 1 to 5) attached.

Port SM	Auxiliary Flow Rate Combiner Solenoid Valve	Auxiliary Flow Rate Combiner Valve Control Pressure
Port SN	Auxiliary Flow Rate Combiner Control Valve	Auxiliary Flow Rate Combiner Valve Control Pressure
Port SP	Auxiliary Flow Rate Combiner Solenoid Valve	Pump 1 Control Pressure

# COMPONENT OPERATION / Signal Control Valve

Pilot Valve Side

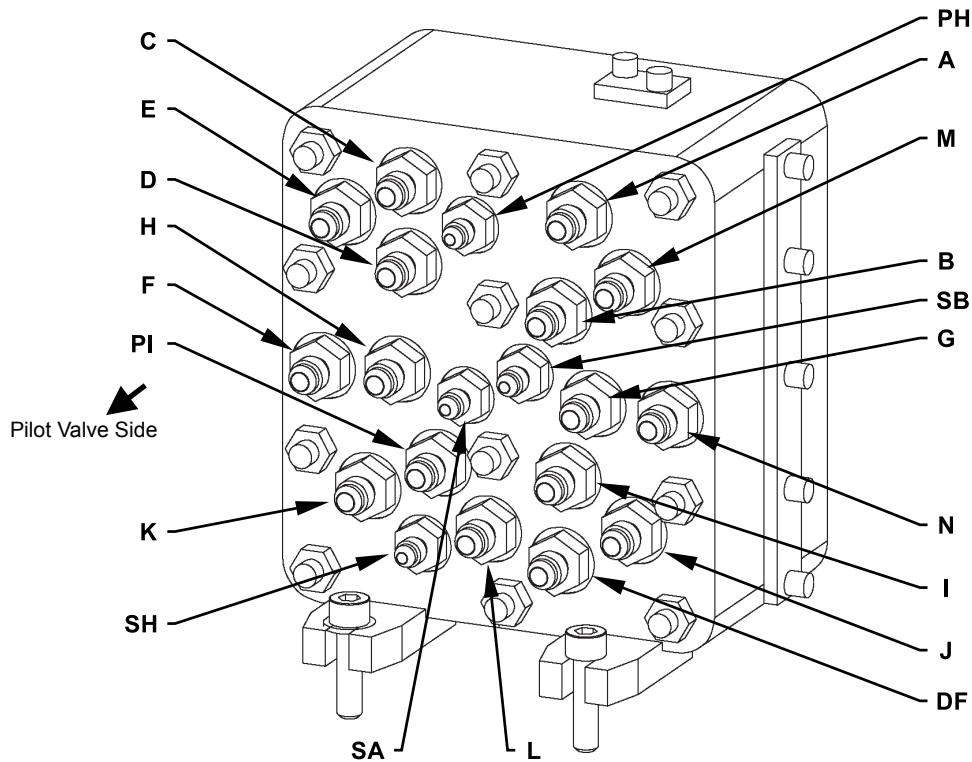

T178-03-06-016

Control Valve Side

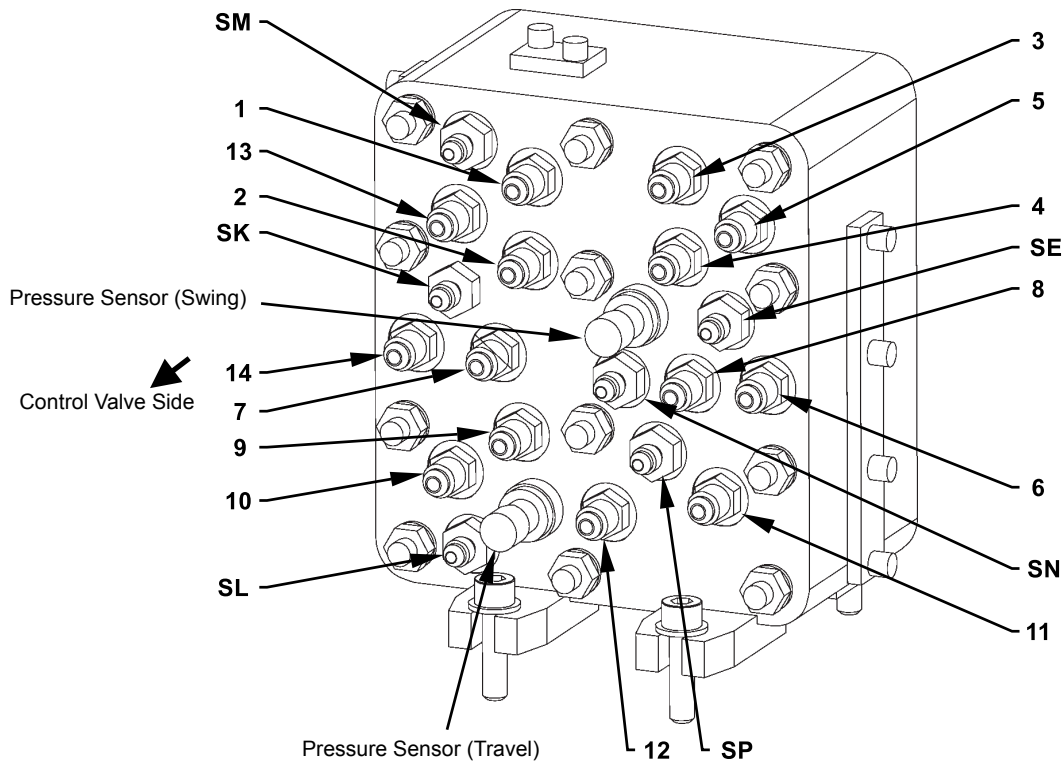

T178-03-06-015

## COMPONENT OPERATION / Signal Control Valve

### SHUTTLE VALVE

The shuttle valve selects pilot pressure oil to perform each operation and routes pilot pressure to the corresponding flow rate control valves and/or switch valve spools. The flow rate control valves and/or switch valve spools corresponding to each operation are as follows:

	Pump 1 Flow Rate Control Valve	Pump 2 Flow Rate Control Valve	Flow Combiner Valve Control Spool	Bucket Flow Rate Control Valve Control Spool	Swing Parking Brake Release Spool	Arm Flow Rate Control Valve Control Spool
Boom Raise	○	○	-	-	○	-
Boom Lower	○	-	-	-	○	-
Arm Roll- Out	○	○	-	-	○	-
Arm Roll- In	○	○	-	○	○	○
Bucket Roll-In	○	-	-	-	○	-
Bucket Roll-Out	○	-	-	-	○	-
Right Swing	-	○	-	-	○	-
Left Swing	-	○	-	-	○	-
Right Travel	○	-	○	-	-	-
Left Travel	-	○	-	-	-	-
Auxiliary	*○	○	-	-	○	-
Positioning (2-Piece Boom Only)	○	-	-	-	-	-

 **NOTE:** \*As for the match with front attachment (secondary crushers 1 to 5 and hydraulic crushers 1 to 5) attached, the pump 1 flow rate control valve is operated by pressure from the auxiliary pilot valve.

# COMPONENT OPERATION / Signal Control Valve

## Monoblock Boom / STD Specification

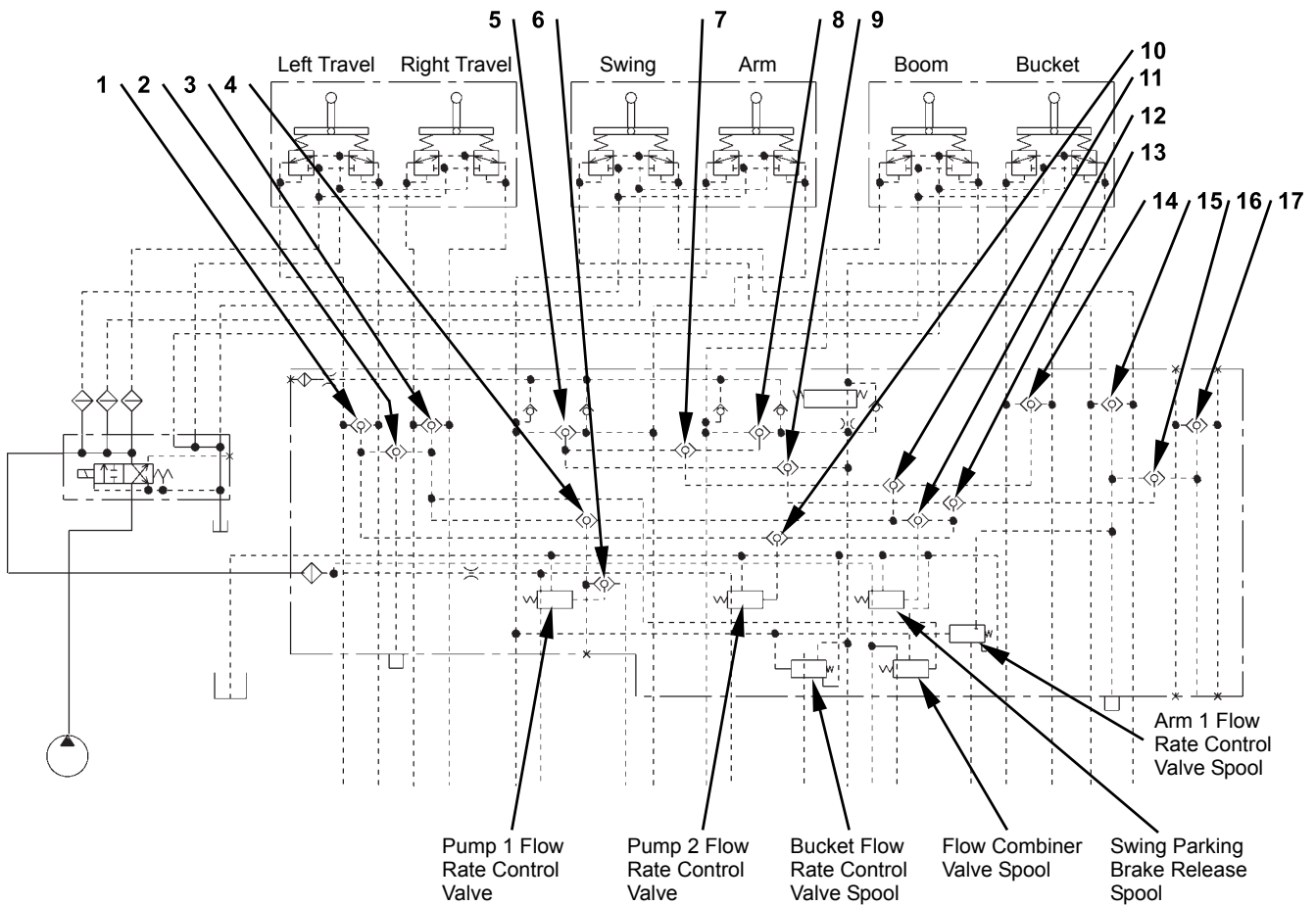

T1V1-03-06-001

- |  |  |  |                        |
|--|--|--|------------------------|
| 1 - Left Travel                        | 6 - Boom / Arm / Bucket / Right Travel / Auxiliary / Positioning | 11 - Boom / Arm / Bucket                     | 16 - Swing / Auxiliary |
| 2 - Left Travel/Right Travel           | 7 - Boom / Arm   | 12 - Boom / Arm / Bucket / Swing / Auxiliary | 17 - Auxiliary         |
| 3 - Right Travel                       | 8 - Boom   | 13 - Arm / Boom Raise / Swing / Auxiliary    |                        |
| 4 - Boom / Arm / Bucket / Right Travel | 9 - Arm / Boom Raise   | 14 - Bucket                                  |                        |
| 5 - Arm                                | 10 - Boom Raise / Arm / Left Travel / Swing                      | 15 - Swing                                   |                        |

# COMPONENT OPERATION / Signal Control Valve

## Machine with Monoblock Boom and Auxiliary Flow Combining Attached (Optional)

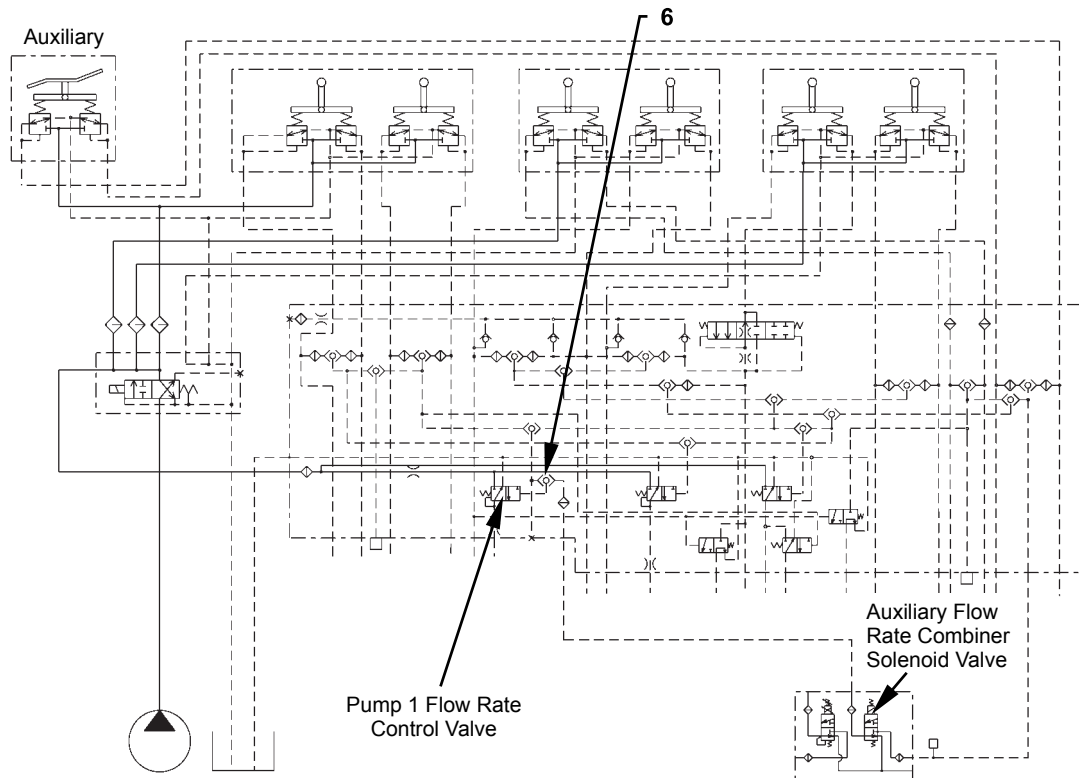

T1V1-03-06-007

## Machine with 2-Piece Boom and Auxiliary Combining Attached (Optional)

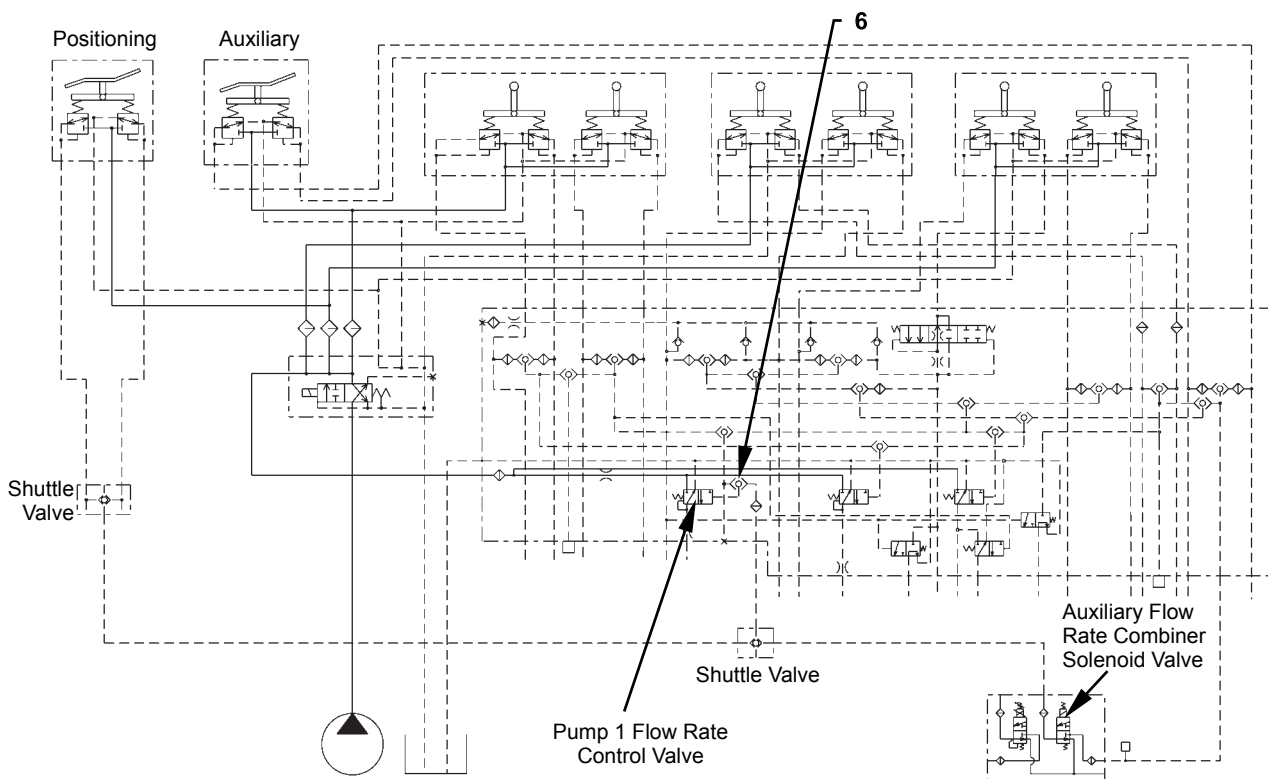

T1V1-03-06-006

# COMPONENT OPERATION / Signal Control Valve

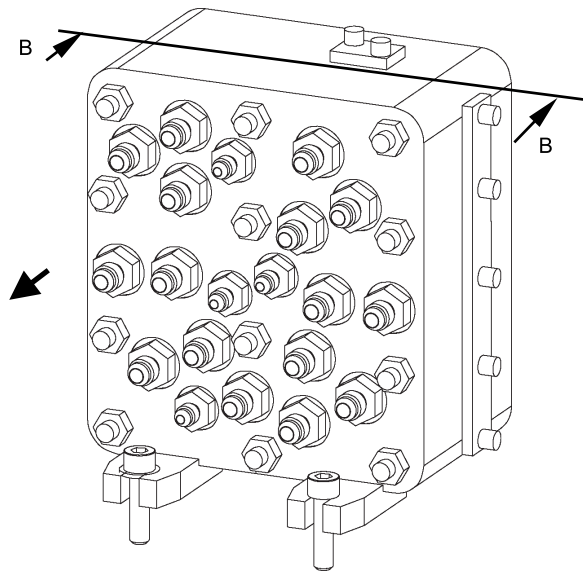

T178-03-06-016

Cross Section B-B

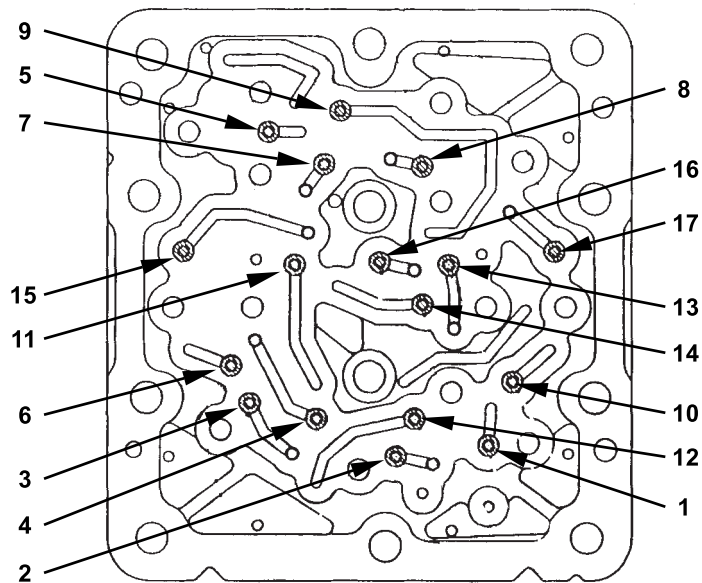

T178-03-06-009

- |  |  |  |                        |
|--|--|--|------------------------|
| 1 - Left Travel                        | 6 - Boom / Arm / Bucket / Right Travel / Auxiliary / Positioning | 11 - Boom / Arm / Bucket                     | 16 - Swing / Auxiliary |
| 2 - Left Travel/Right Travel           | 7 - Boom / Arm   | 12 - Boom / Arm / Bucket / Swing / Auxiliary | 17 - Auxiliary         |
| 3 - Right Travel                       | 8 - Boom   | 13 - Arm / Boom Raise / Swing / Auxiliary    |                        |
| 4 - Boom / Arm / Bucket / Right Travel | 9 - Arm / Boom Raise   | 14 - Bucket                                  |                        |
| 5 - Arm                                | 10 - Boom Raise / Arm / Left Travel / Swing                      | 15 - Swing                                   |                        |



## COMPONENT OPERATION / Signal Control Valve

### SHOCKLESS VALVE

The shockless valve is provided in the boom raise circuit and functions during boom lowering operation.

#### During Boom Raising Operation:

1. Boom raise pilot pressure oil is routed into port A and acts on the spool.
2. Immediately after operation is started, low pilot pressure oil flows into the spring B chamber through clearance between spool and housing. At the same time, pilot pressure oil flows to port 1 through inner passage 2.
3. When pilot pressure increases, pressure in the spring B chamber increases, and the spool pushes spring A and moves to the left.
4. As the spool is moved, port A is connected to port 1 and pressure in port 1 increase so that the spool in control valve is moved.

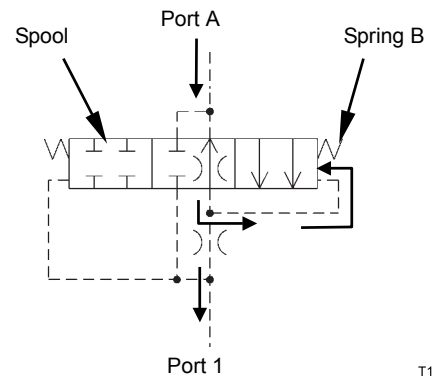

T1V1-03-06-003

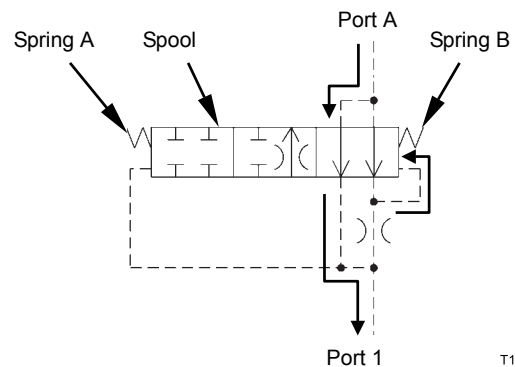

T1V1-03-06-002

# COMPONENT OPERATION / Signal Control Valve

## During Boom Raising Operation

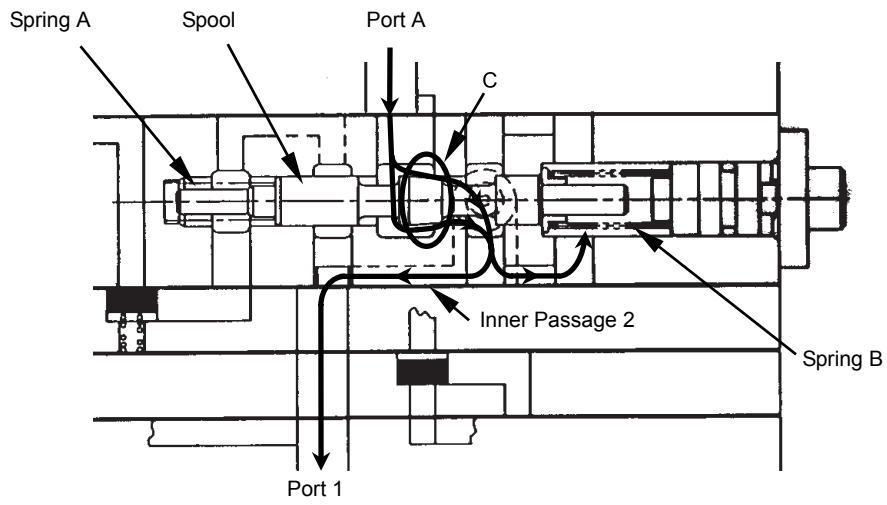

T183-03-06-003

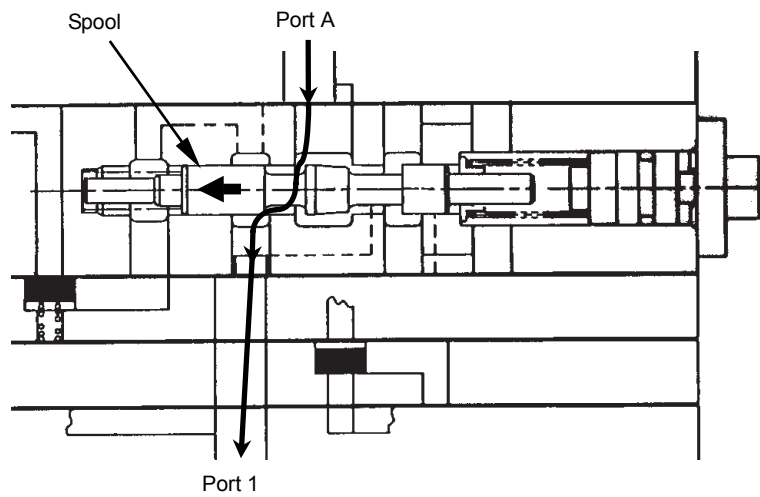

T183-03-06-004

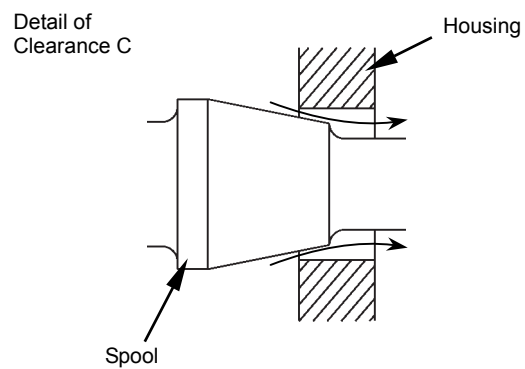

T1V1-03-06-008

## COMPONENT OPERATION / Signal Control Valve

### During Boom Lowering Operation (Shock Reducing Operation)

1. When the boom is lowered, the return oil from the boom raise spool in the control valve is routed to port 1.
2. As the spool blocks the oil passage between port 1 and port A, return oil cannot flow directly to port A.
3. Port 1 is connected to the spring A side in spool and to the oil chamber via inner passage 2.
4. Pressure oil in the oil chamber flows from clearance C between spool and housing and pressure in the oil chamber decreases. The spool is moved to the right by pressure acting on the spring A side. Thereby, clearance C between the spool and housing is closed and pressure oil is blocked.
5. When clearance C is closed, pressure in the oil chamber increases and the spool moves to the left. Therefore, clearance C is opened again and pressure oil flows to port A.
6. As operations in steps (4 and 5) are repeated, pressure oil is gradually returned to port A so that the control spool returns slowly.

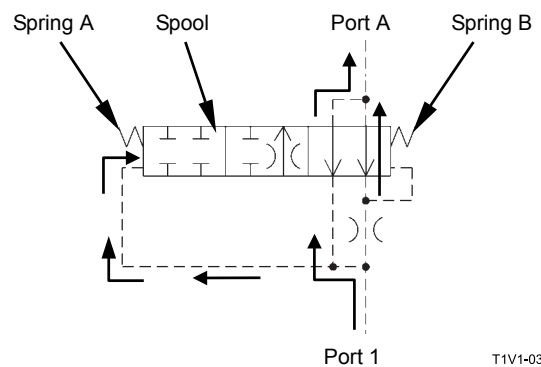
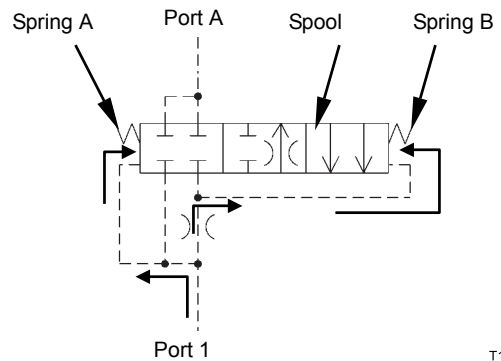

# COMPONENT OPERATION / Signal Control Valve

During Boom Lowering Operation (Shockless Operation)

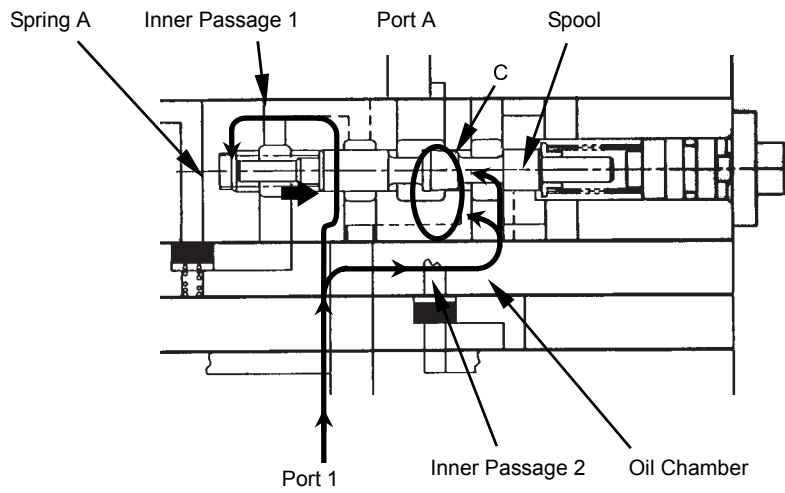

T183-03-06-005

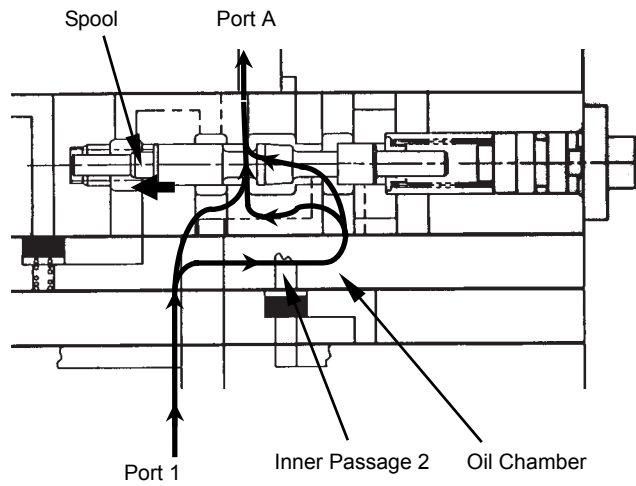

T183-03-06-004

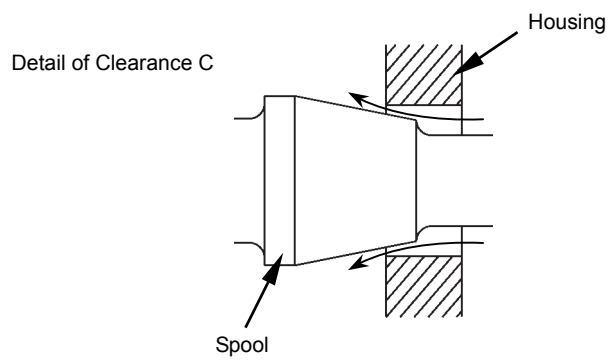

T1V1-03-06-008

## COMPONENT OPERATION / Signal Control Valve

---

### PUMP 1 AND PUMP 2 FLOW RATE CONTROL VALVES

The pump flow rate control valve delivers pump control pressure  $P_i$  to the pump regulator in response to pilot pressure from the pilot valve.

1. Pilot oil pressure from the pilot valve is routed into the chamber A side in either the pump 1 or pump 2 flow rate control valve after being selected by the shuttle valves in signal control valve.
2. The spool is moved to the left and primary pilot pressure flows in either port SA or SB.
3. Therefore, pressure in port SA or SB increases.
4. Pressure oil in port SA or SB acts on the spring chamber. Thus, the spool is moved back until pressure force balances with pilot pressure force in the chamber A side so that pressure in port SA or SB stops increasing.

 **NOTE:** *The pump 1 flow rate control valve operates when the boom (raise or lower), arm (roll-in or out), bucket (roll-in or out), auxiliary (machine with front attachment (secondary crushers 1 to 5, hydraulic crushers 1 to 5) attached) travel (right) and positioning functions are operated. The pump 2 flow rate control valve operates when the boom (raise), arm (roll-in or out), swing (right or left), travel (left) and auxiliary functions are operated.*

# COMPONENT OPERATION / Signal Control Valve

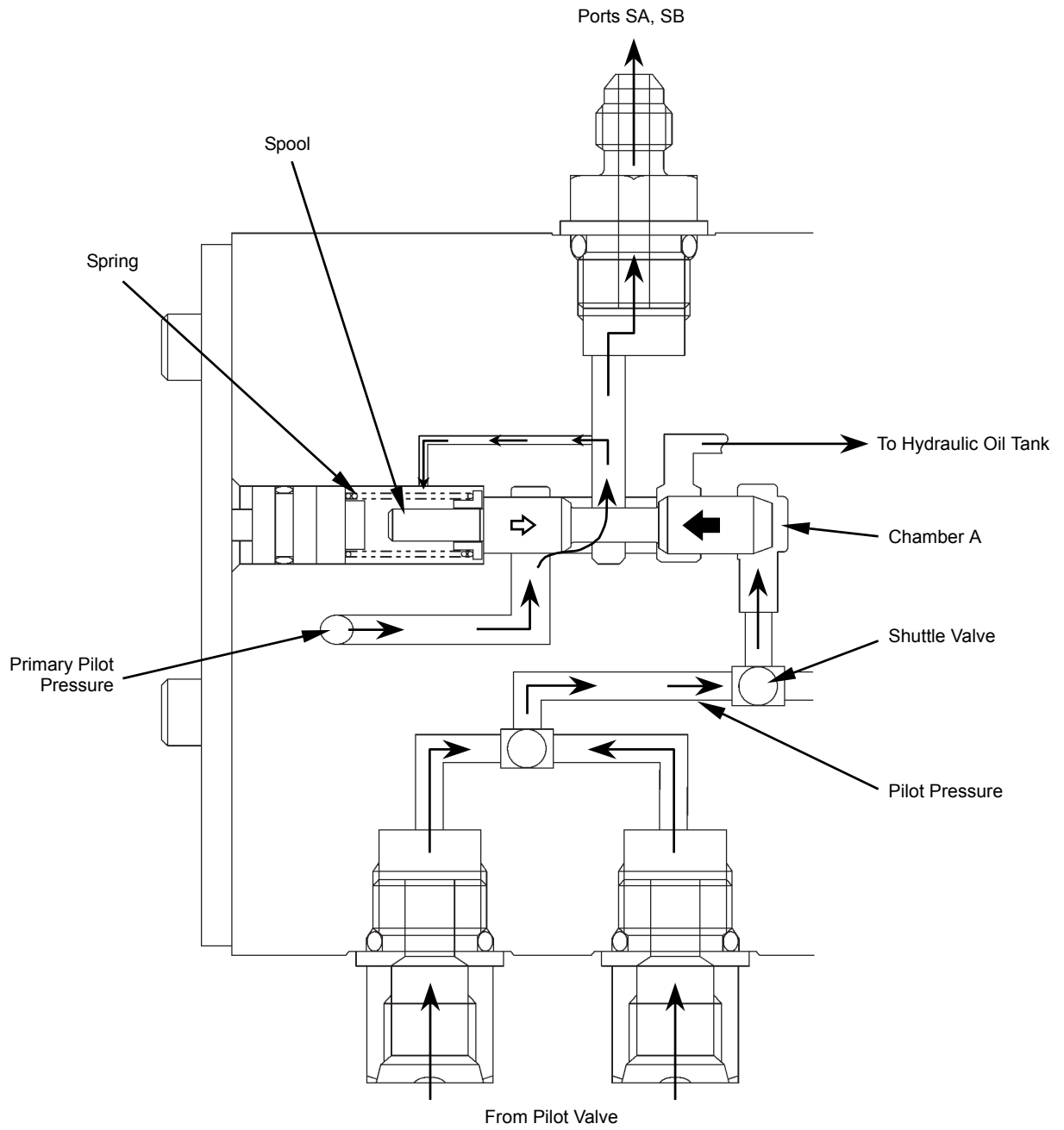

T1V1-03-06-005

## COMPONENT OPERATION / Signal Control Valve

### BUCKET FLOW RATE CONTROL VALVE CONTROL SPOOL, FLOW COMBINER VALVE CONTROL SPOOL, SWING PARKING BRAKE RELEASE SPOOL, ARM 1 FLOW RATE CONTROL VALVE CONTROL SPOOL

 **NOTE:** The spools above are identical in operational principle.

1. The bucket flow rate control valve control spool is shifted by arm roll-in control pilot pressure and supplies boom raise control pilot pressure to the bucket flow rate control valve in control valve.
2. The flow combiner valve control spool is shifted by right travel control pilot pressure and supplies primary pilot pressure to the flow combiner valve in control valve.
3. The swing parking brake release spool is shifted by the boom, arm, bucket, swing or auxiliary control pilot pressure and supplies primary pilot pressure to the swing motor.
4. The arm flow rate control valve control spool is shifted and by arm roll-in control pilot pressure and supplies swing control pilot pressure to the arm 1 flow rate control valve in control valve.

Bucket Flow Rate Control Valve Control Spool:

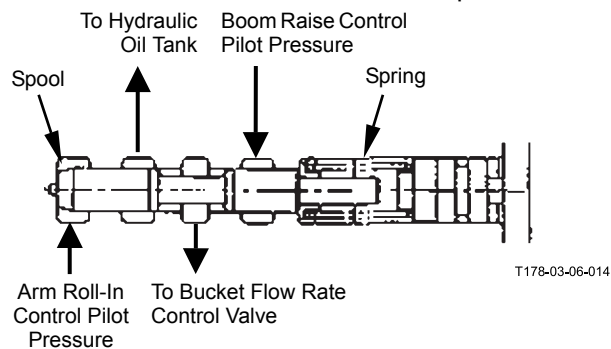

Flow Combiner Valve Control Spool:

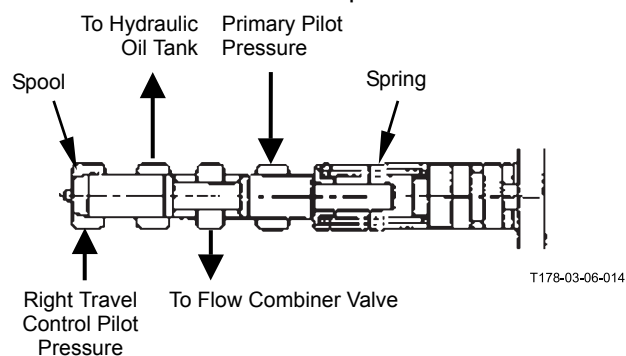

Swing Parking Brake Release Spool:

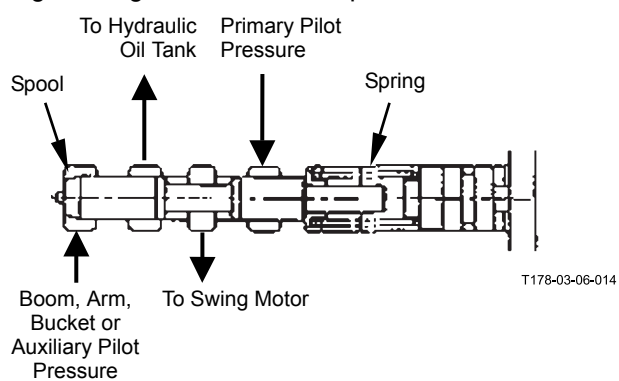

Arm 1 Flow Rate Control Valve Control Spool:

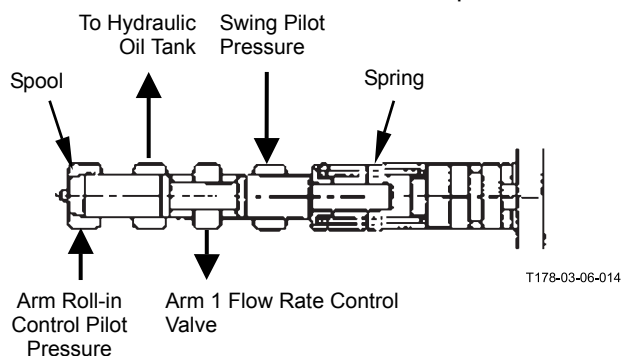

## COMPONENT OPERATION / Others (Upperstructure)

### PILOT SHUT-OFF SOLENOID VALVE

The pilot shut-off solenoid valve is a solenoid valve-operated switch valve.

The spool in pilot shut-off solenoid valve is shifted by the pilot shut-off lever and turns on or off pilot pressure oil to the pilot valve and signal control valve.

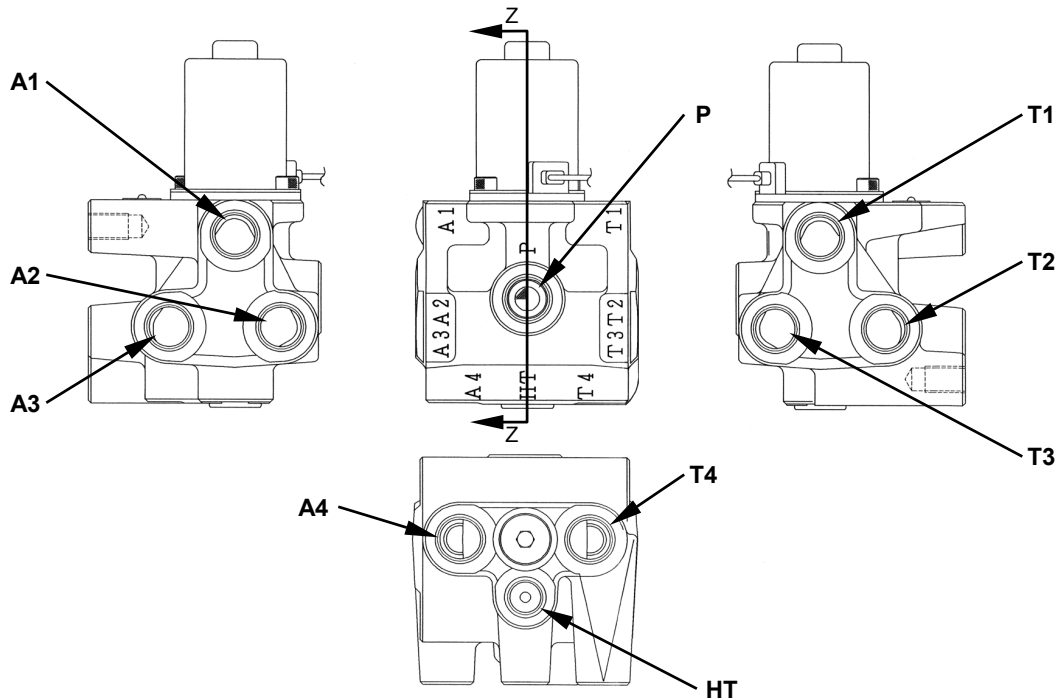
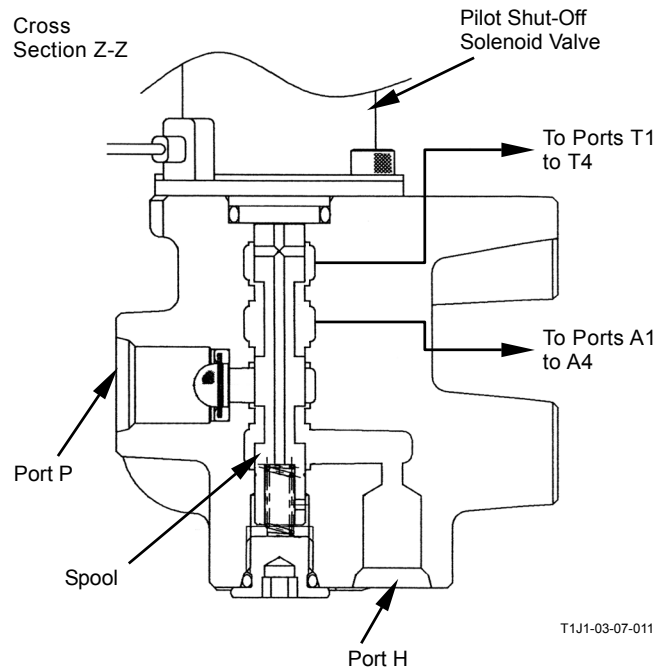

A1 - Travel / Auxiliary Pilot Valve  
 A2 - Right Pilot Valve  
 A3 - Left Pilot Valve

A4 - Unused  
 HT - Signal Control Valve (Port PH)  
 P - Primary Pilot Pressure

T1 - Travel / Auxiliary Pilot Valve  
 T2 - Right Pilot Valve

T3 - Left Pilot Valve  
 T4 - Hydraulic Oil Tank



## COMPONENT OPERATION / Others (Upperstructure)

- Pilot Shut-Off Lever: LOCK Position

1. When the pilot shut-off lever is in the LOCK position, the pilot shut-off relay is turned OFF and the pilot shut-off solenoid valve is turned OFF. (Refer to Electrical System/ SYSTEM.)
2. Pressure oil from the pilot pump flows to the signal control valve through the spool in pilot shut-off solenoid valve.
3. Oil from the pilot valve flows to the hydraulic oil tank.
4. Therefore, although the control lever is operated, the pilot valve is not operated.

- Pilot Shut-Off Lever: UNLOCK Position

1. When the pilot shut-off lever is in the UNLOCK position, the pilot shut-off relay is turned ON and the pilot shut-off solenoid valve is activated.
2. Therefore, the Circuit to signal control valve and hydraulic oil tank are blocked by the spool in pilot shut-off valve.
3. Pressure oil from the pilot pump flows to the pilot valve.
4. Consequently, when the control lever is operated, the pilot valve is operated.

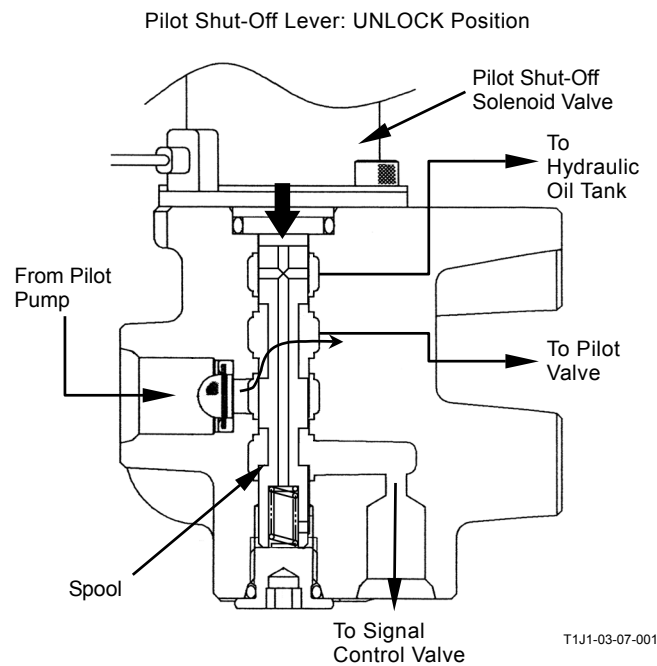
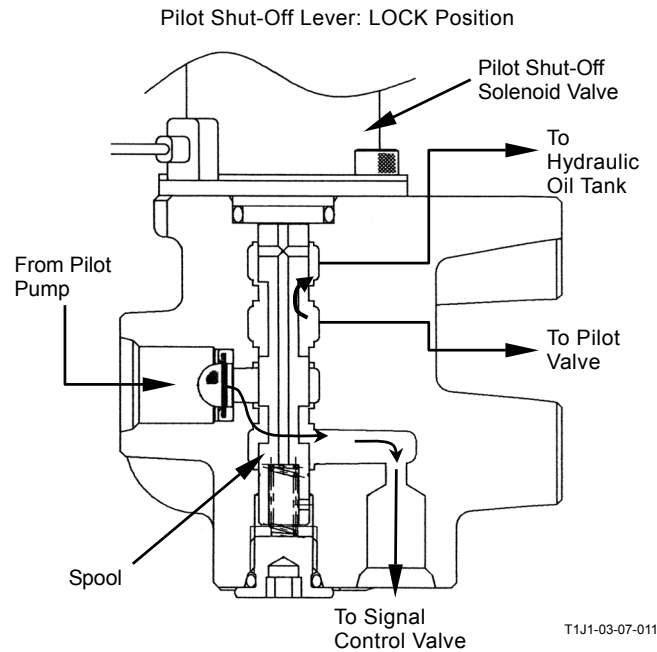

## COMPONENT OPERATION / Others (Upperstructure)

---

### 4-SPOOL SOLENOID VALVE UNIT

Controls the control valve and the valve in travel motor by the signal from MC (main controller). (Refer to Control System / SYSTEM.) The 4-spool solenoid valve unit consists of proportional solenoid valves (SC, SF, SI and SG).

- SC: Control the boom overload relief control valve in control valve
- SF: Control the boom flow rate control valve (switch valve) in control valve
- SI: Control the travel motor swash angle control valve
- SG: Increase pressure of the main relief valve in control valve

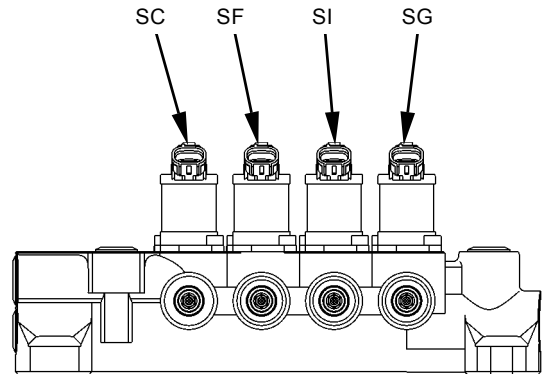

T1V1-03-07-007

## COMPONENT OPERATION / Others (Upperstructure)

### Proportional Solenoid Valve

Controls by an electric current signal from MC and outputs pressure in proportional to degree of the electric current.

• When not energized (In neutral):

1. Spring (2) pushes spool (1) to the right and output port S is connected to tank port T.

• When energized:

1. Solenoid (3) pushes spool (1) to the left due to force in proportional to the electric current flowing through solenoid (3).
2. Pilot oil pressure from port P flows into output port S and pressure at output port S increases.
3. Pressure at output port S acts on step part a on spool (1).  
Because of difference in the pressure receiving area between step part a, spool (1) is pushed to the right.
4. When pressure at port S increases and the force to push spool (1) to the right overcomes the force to push spool (1) to the left by solenoid (3), spool (1) moves back to the right side and the passage between output port S and port P is closed. As a result, pressure increase at port S stops.

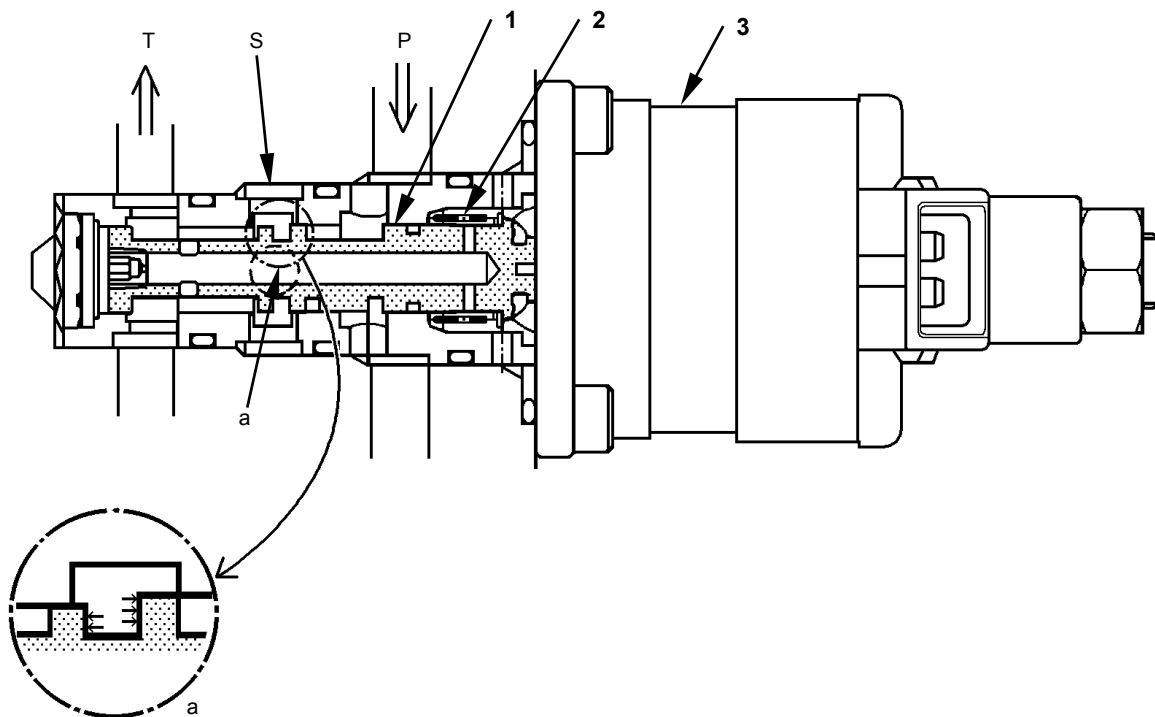

T107-02-07-005

1 - Spool

2 - Spring

3 - Solenoid

## COMPONENT OPERATION / Others (Upperstructure)

---

### PILOT RELIEF VALVE

The pilot relief valve has a pilot filter incorporated. The pilot relief valve functions to regulate pilot pump pressure oil routed to port P to a set constant pressure.

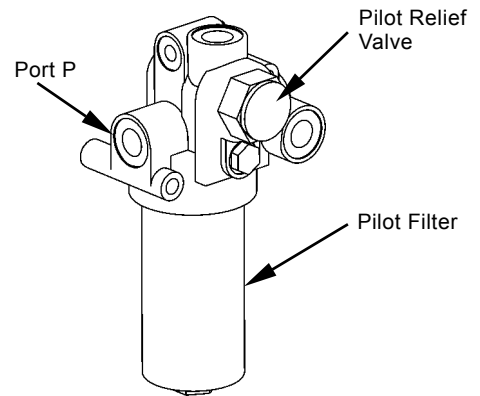

T178-03-07-001

## COMPONENT OPERATION / Others (Upperstructure)

---

### FAN MOTOR

The oil cooler fan motor is a inclined-shaft type, fixed displacement axial plunger motor. The operating principle of this motor is the same as the travel motor. (Refer to the Travel Device section in this manual.)

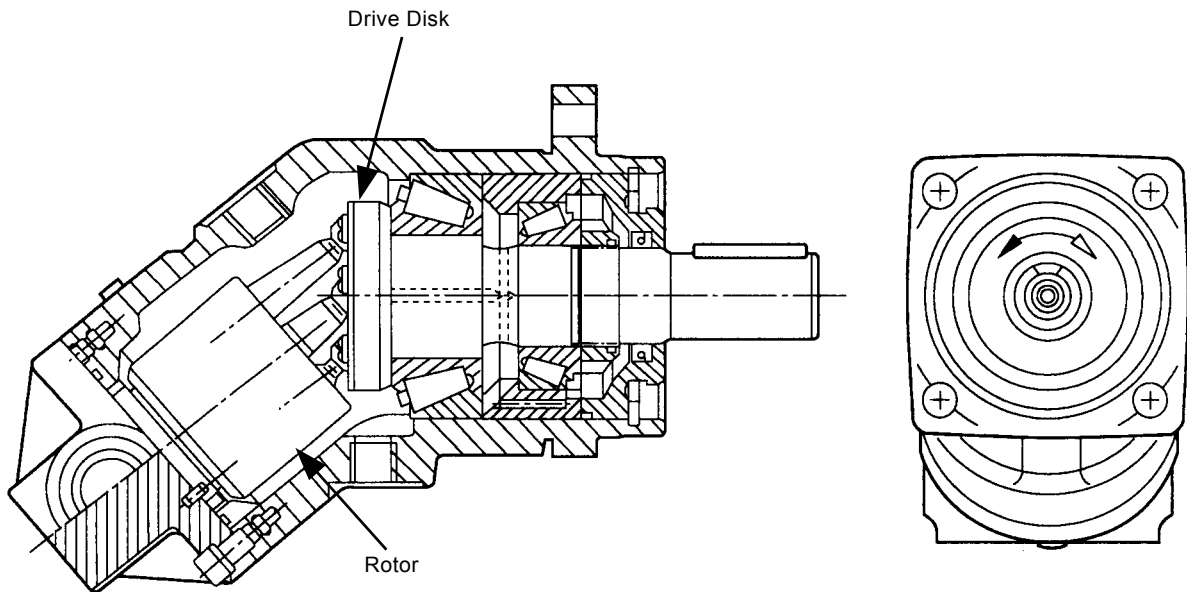

T142-06-04-021

## COMPONENT OPERATION / Others (Upperstructure)

### FAN VALVE

The fan valve (standard) consists of make-up valve and relief valve.

The make-up valve prevents cavitation in the circuit and the relief valve prevents surge pressure and overloads in the circuit.

The fan valve (optional) consists of make-up valve, relief valve and solenoid valve.

The make-up valve prevents cavitation in the circuit and the relief valve prevents surge pressure and overloads in the circuit.

When the solenoid valve is shifted, pressure oil from the fan pump (port P1) is shifted to port M1 or M2. Therefore, rotation of the fan motor is switched to forward or reverse rotation.

Fan Valve (Standard)

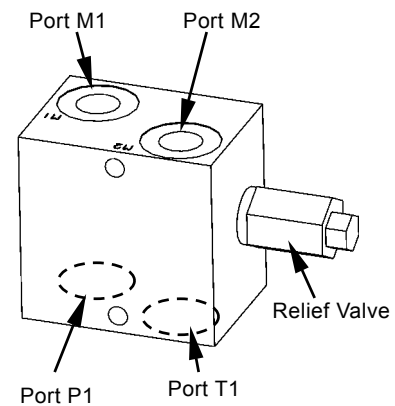

T1J1-03-07-003

Fan Valve (Optional)

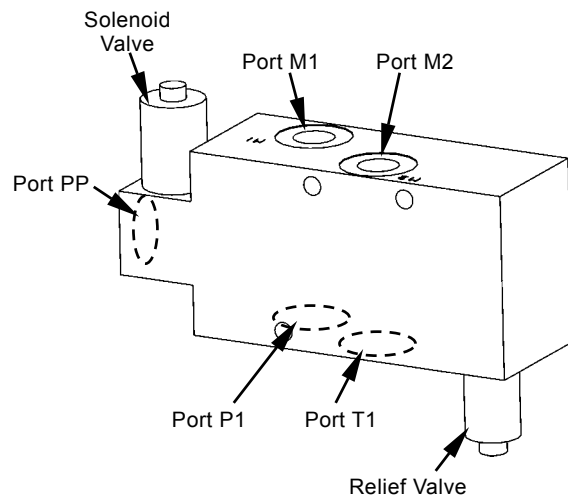

T1J1-03-07-004

## COMPONENT OPERATION / Others (Upperstructure)

### SHOCKLESS VALVE

The shockless valve is provided in the boom lower circuit and operated when the boom lower control lever is suddenly returned.

#### Operation

1. When the boom lower control lever is returned, return oil from the spool in control valve (boom lower side) acts on port A.
2. Oil in port A flows to chamber D (1) through orifice (6).
3. Pressure in chamber D (1) is routed to port B through passage (2) in spool (5) and housing (4), so that pressure in chamber D (1) decreases.
4. As pressure difference between front and rear of orifice (6) occurs, spool (5) is move to the left by pressure acting on the spring (3) side. Therefore, passage (2) in spool (5) and housing (4) is closed and pressure oil is blocked.
5. When passage (2) is closed, pressure in chamber D (1) increases and spool (5) moves to the right. Passage (2) is open again and pressure oil flows to port B.
6. By repeating steps 3 to 5, pressure oil returns to the port B side gradually, so that the spool in control valve is slowly returned.

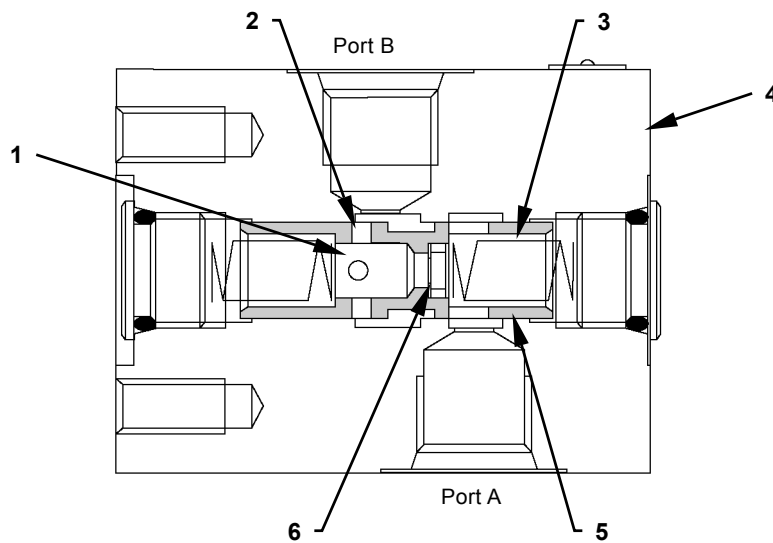

T1J1-03-07-012

1 - Chamber D  
2 - Passage

3 - Spring  
4 - Housing

5 - Spool

6 - Orifice

## COMPONENT OPERATION / Others (Upperstructure)

### ACCUMULATOR

The accumulator is provided in the pilot circuit in order to buffer fluctuations in oil pressure, and to maintain pilot pressure for a short time period after the engine is stopped.

The accumulator mainly consists of body (5), holder (4), bladder (2), which encloses nitrogen gas ( $N_2$ ), and poppet (1).

- Pressure oil from the pilot pump enters into the accumulator through port A pilot pressure compresses bladder (2) until the nitrogen gas balances against with bladder (2).
- When pressure supply is stopped due to engine stall or any other reasons, bladder (2) starts expanding and accumulated oil is supplied to the pilot circuit through port A.

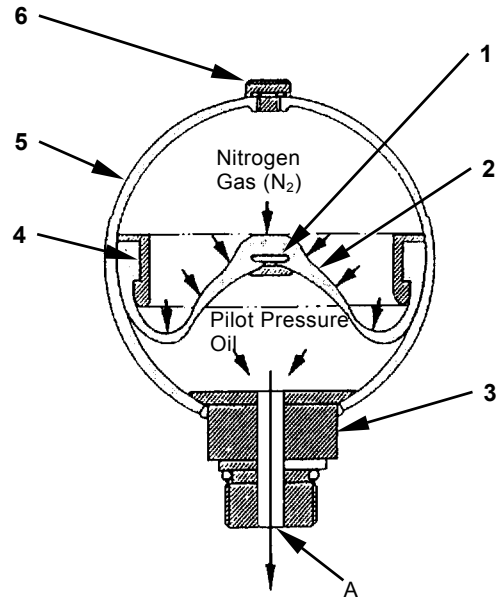

T105-02-10-003

- |              |              |
|--------------|--------------|
| 1 - Poppet   | 4 - Holder   |
| 2 - Bladder  | 5 - Body     |
| 3 - Oil Port | 6 - Gas Plug |



## COMPONENT OPERATION / Others (Upperstructure)

### DISTRIBUTION VALVE (OPTIONAL)

The distribution valve is provided in the auto lubrication circuit and distributes grease from the grease pump to each lubrication position.

The proximity switch detects grease amount to be distributed and outputs the signal to MC.

(Refer to Auto Lubrication Control / Control System group.)

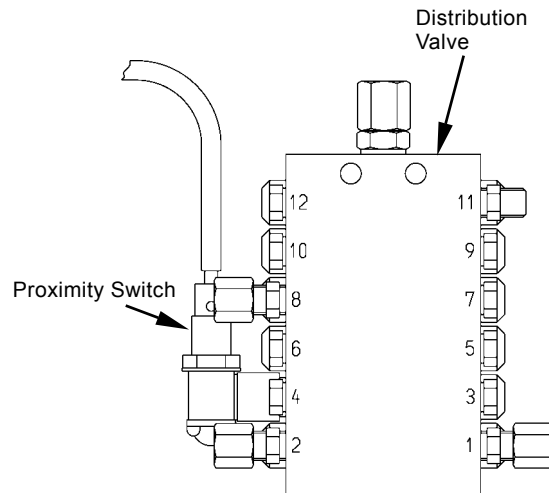

T1J1-03-07-005

#### Operation

1. Grease from the grease pump acts on the right side of piston A through passage G.
2. Therefore, piston A moves to the left. Grease at the left side of piston A flows to port 2 through passage H and piston F.

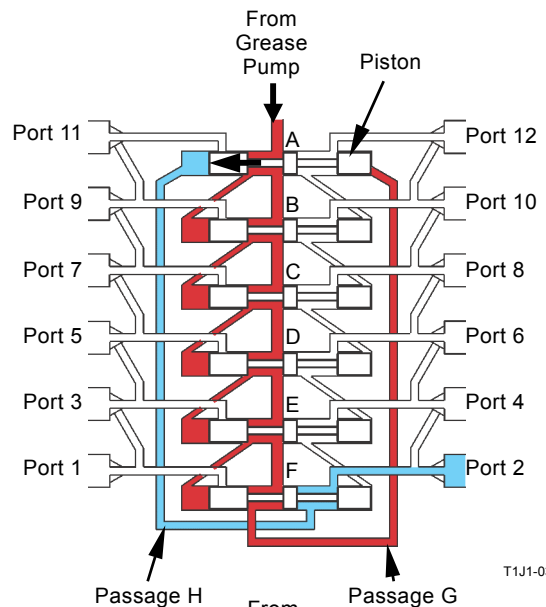

T1J1-03-07-006

3. When piston A moves to the left, grease from the grease pump acts on the right side of piston B through passage I.
4. Therefore, piston B moves to the left. Grease at the left side of piston B flows to port 11 through passage J and piston A.

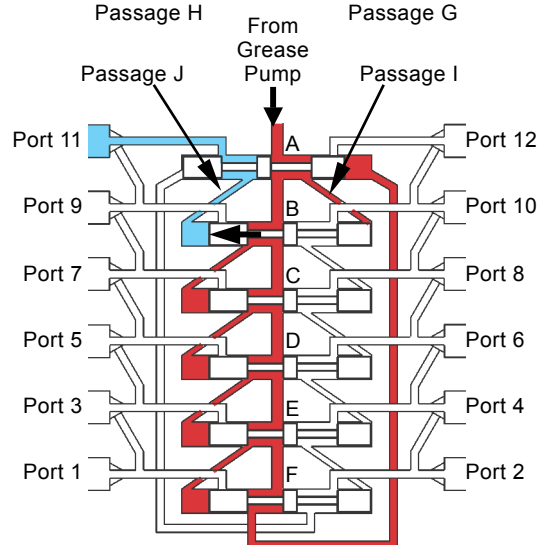

T1J1-03-07-007

## COMPONENT OPERATION / Others (Upperstructure)

5. When piston B moves to the left, grease from the grease pump acts on the right side of piston C through passage K.
6. Therefore, piston C moves to the left. Grease at the left side of piston C flows to port 9 through passage L and piston B.
7. By repeating steps 3 to 6, grease is supplied to ports 11, 9, 7, 5 and 3 in this order.

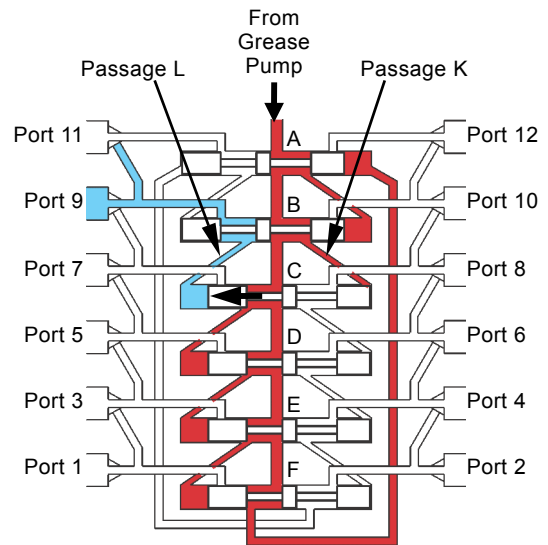

T1J1-03-07-008

8. When piston F moves to the left, grease from the grease pump acts on the left side of piston A through passage H.
9. Therefore, piston A moves to the right. Grease at the right side of piston A flows to port 1 through passage G and piston F.

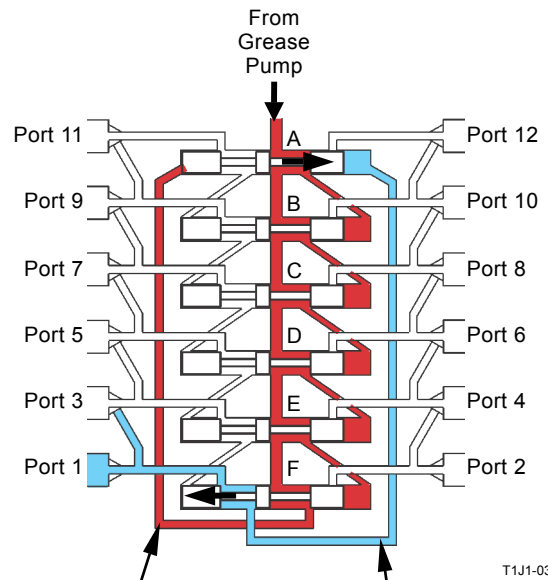

T1J1-03-07-009

10. When piston A moves to the right, grease from the grease pump acts on the left side of piston B through passage J.
11. Therefore, piston B moves to the right. Grease at the right side of piston B flows to port 12 through passage I and piston A.
12. By repeating steps 10, 11, grease is supplied to ports 12, 10, 8, 6 and 4 in this order.

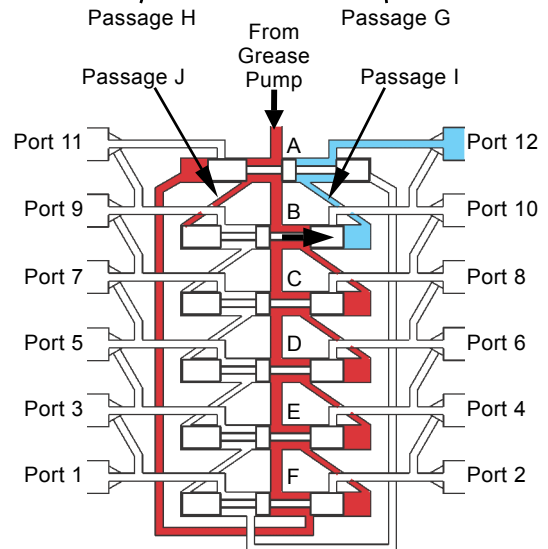

T1J1-03-07-010

## COMPONENT OPERATION / Others (Upperstructure)

---

(Blank)

## COMPONENT OPERATION / Others (Undercarriage)

### SWING BEARING

The swing bearing supports the upperstructure weight and functions to rotate the upperstructure smoothly. This bearing is a single-row shear ball-type bearing and consists of outer race (1), inner race (3), ball (6), support (5) and seals (2, 4).

Outer race (1) is bolted to the upperstructure and inner race (3) is bolted to the undercarriage. The internal gear of inner race (3) engages with the output shaft of swing reduction gear.

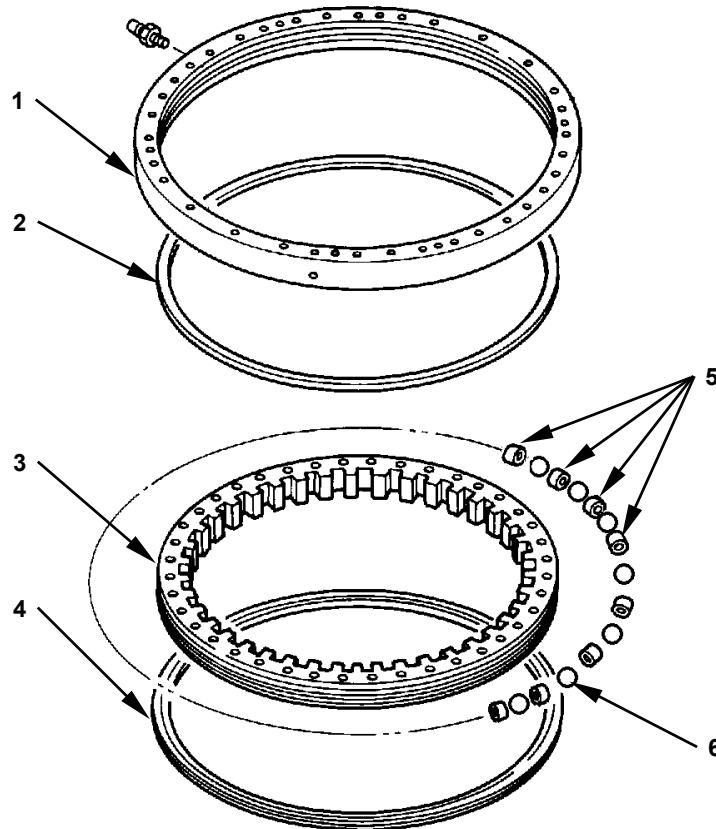

T135-03-02-001

1 - Outer Race  
2 - Seal

3 - Inner Race  
4 - Seal

5 - Support

6 - Ball

## COMPONENT OPERATION / Others (Undercarriage)

### CENTER JOINT

The center joint is a 360° rotating joint. The center joint allows pressure oil to flow smoothly to the travel motor without twisting the hoses while the upperstructure is rotated.

The spindle is fixed to the upperstructure, and the body is fixed to the swing center of undercarriage.

Pressure oil flows to the right and left travel motors from each port of the body through the spindle. The seal prevents oil leaks between spindle and body.

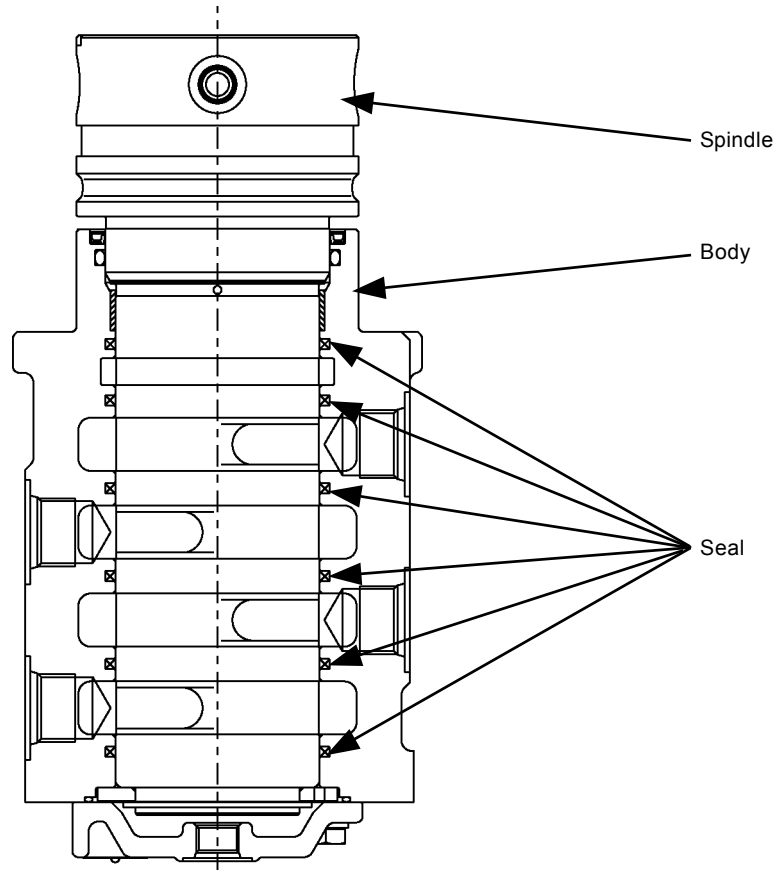

T16J-03-07-001

## COMPONENT OPERATION / Others (Undercarriage)

### TRACK ADJUSTER

The track adjuster consists of spring (5) and adjuster cylinder (6), and is supported by the side frame. Spring (5) absorbs loads applied to the front idler. Piston rod (8) adjusts track sag.

- Grease is applied through the grease fitting into part a of adjuster cylinder (6). Grease pushes piston rod (8) and decreases track sag.
- In order to increase track sag, loosen the hexagonal part of valve (1) 1 to 1.5 turns counterclockwise and release grease.

**CAUTION:** Adjuster cylinder (6) is highly pressurized. As valve (1) may fly out and the highly pressurized grease may spout out, do not loosen valve (1) quickly and/or excessively. Keep face and body parts away from valve (1) and loosen valve (1) slowly and gradually. In addition, do not loosen the grease fitting.

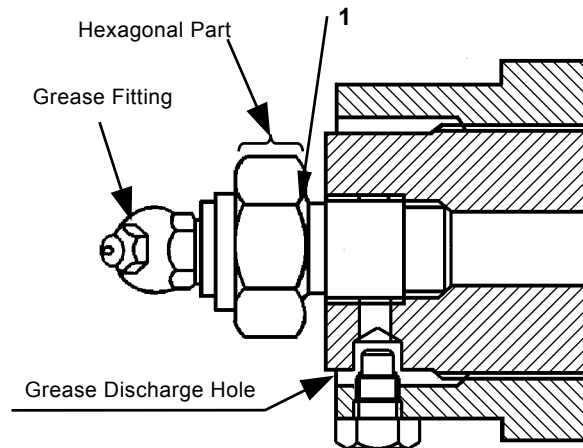

T1J1-03-08-002

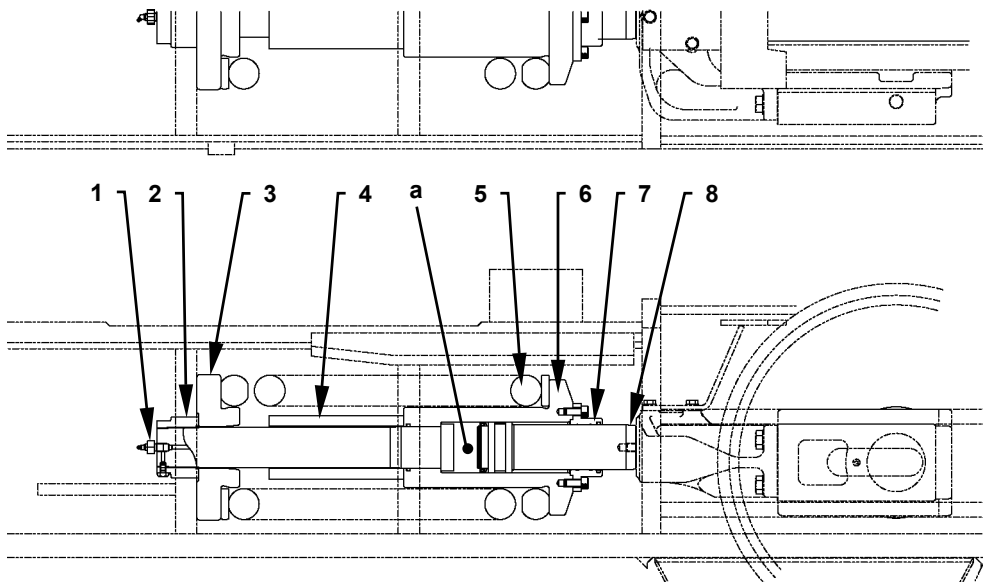

T1J1-03-08-001

1 - Valve  
2 - Nut

3 - Washer  
4 - Spacer

5 - Spring  
6 - Adjuster Cylinder

7 - Flange  
8 - Piston Rod

**COMPONENT OPERATION / Others (Undercarriage)**

---

---

(Blank)







Hitachi Construction Machinery Co. Ltd  
Attn: Publications, Marketing & Product Support  
Fax: 81-298-31-1162

Hitachi Ref. No.

---

---

## SERVICE MANUAL REVISION REQUEST FORM

---

---

NAME OF COMPANY:

MODEL:

YOUR NAME:

PUBLICATION NO.:

(Located at the right top corner in the cover page)

DATE:

PAGE NO.:

(Located at the bottom center in the page. If two or more revisions are requested, use the comment column)

FAX:

---

YOUR COMMENTS / SUGGESTIONS:

Attach photo or sketch if required.

If your need more space, please use another sheet.

---

REPLY:

---

(Copy this form for usage)