

HITACHI

Training Text

ZAXIS

200-3 class

240-3 class

270-3 class

GENERAL INFORMATION

Technical Training Center

Contents

Overview (Front)	1
Overview (Side).....	1
Overview (Rear)	3
Cab (STD).....	3
Air Conditioner (Fresh Air Filter).....	5
Air Conditioner (Circulating Air Filter)	5
Cab Interior	7
Cab Floor	7
Emergency Engine Stop Switch	9
Multi-Function Monitor.....	9
Switch Panel (Right)	11
Switch Panel (Left)	11
Pilot Control Shut-Off Lever	13
Pilot Valve & Shut-Off Switch	13
Rear Tray	15
Electrical Parts in Cab	15
Engine Compartment with Cover	17
Engine.....	17
Cooled EGR System Sensors	19
Crank Speed Sensor & Sensors.....	19
Coolant Temp. Sensor.....	21
Common Rail Pressure Sensor.....	21
Main Fuel / Pre-Fuel Filter & Fuel Pump	23
Engine Oil Filter.....	23
Engine Oil Drain	25
Engine Oil Drainer	25
Utility Space	27
Engine Control Module (ECM)	27
Air Cleaner and Element	29

Contents

Air Cleaner Restriction Switch.....	29
Atmospheric Pressure Sensor.....	31
Intake Air Temperature Sensor.....	31
Cooling System (Inter Cooler and Radiator, Oil Cooler).....	33
Air Conditioner Condenser and Fuel Cooler.....	33
Battery and Relays.....	35
Pump Compartment.....	35
Pump Device.....	37
Pump Regulator.....	37
Pilot Filter.....	39
Main Component Layout.....	39
Control Valve.....	41
Main and Overload Relief Valve.....	41
Arm Roll-In Pressure Sensor.....	43
Boom-Up Pressure Sensor.....	43
Signal Control Valve.....	45
Swing Device.....	45
Hydraulic Oil Tank.....	47
Hydraulic Oil Temperature Sensor.....	47
Fuel Tank.....	49
Fuel Level Gauge Sensor.....	49
Automatic Fuel Device (Option).....	51
Undercarriage.....	53
Track Frame.....	53
Track Link and Rollers.....	55
Front Idler.....	55
Travel Device.....	57
Travel Motor.....	57
Center Joint (1).....	59

Contents

Center Joint (2)	59
Front Attachment (Standard)	61
Attachment Piping (Standard)	61
Hose Rupture Valve for Mono Boom Type (Option)	63

OVERVIEW (FRONT)



001

OVERVIEW (SIDE)



002

New Model Configuration

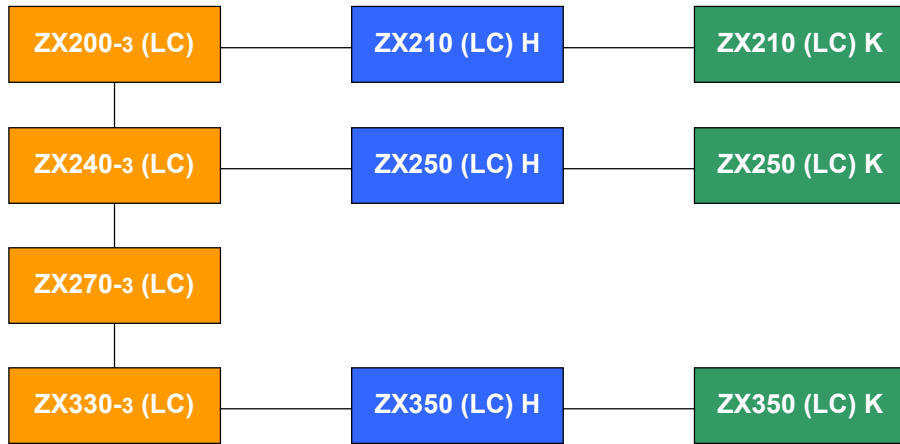

OVERVIEW (REAR)



003

CAB (STD)



004

CRES II Cab (ROPS Type)

- EOPS Type Cab..... Excavators Operator Protection Structure
- ROPS Type Cab..... Roll Over Protective Structures.

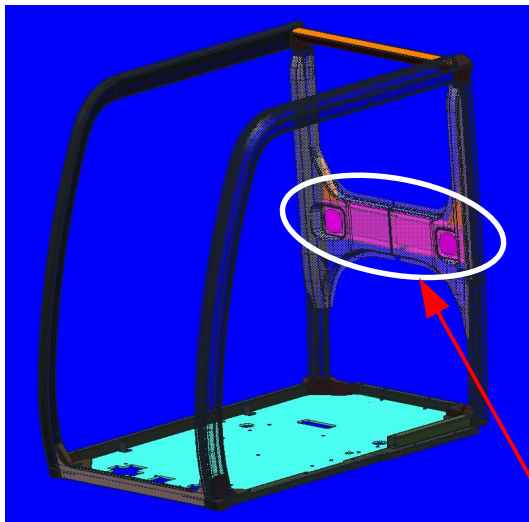

ZX200-3
With Standing Load : 2.5-Fold Increase

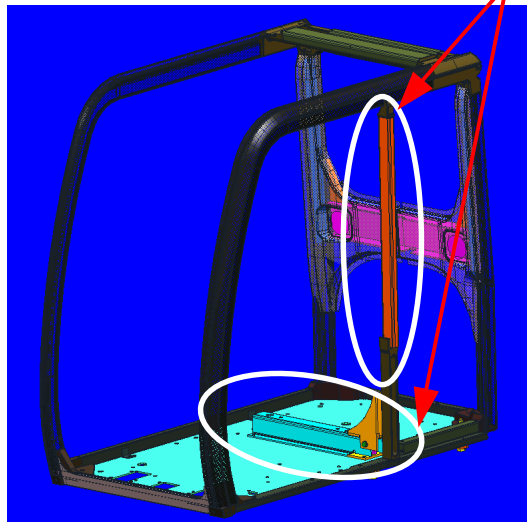

ZX240-3 ~ ZX350-3
With Standing Load : 4-Fold Increase

AIR CONDITIONER (FRESH AIR FILTER)



005

AIR CONDITIONER (CIRCULATING AIR FILTER)



006

Air Conditioner Filter

- Fresh Air Filter Clean Filter : Every 250 hours
Replacement Filter : Every 1000 hours

- Circulating Air Filter Clean Filter : Every 250 hours
Replacement Filter : When Excessively Restricted.

CAB INTERIOR



0682-010

CAB FLOOR

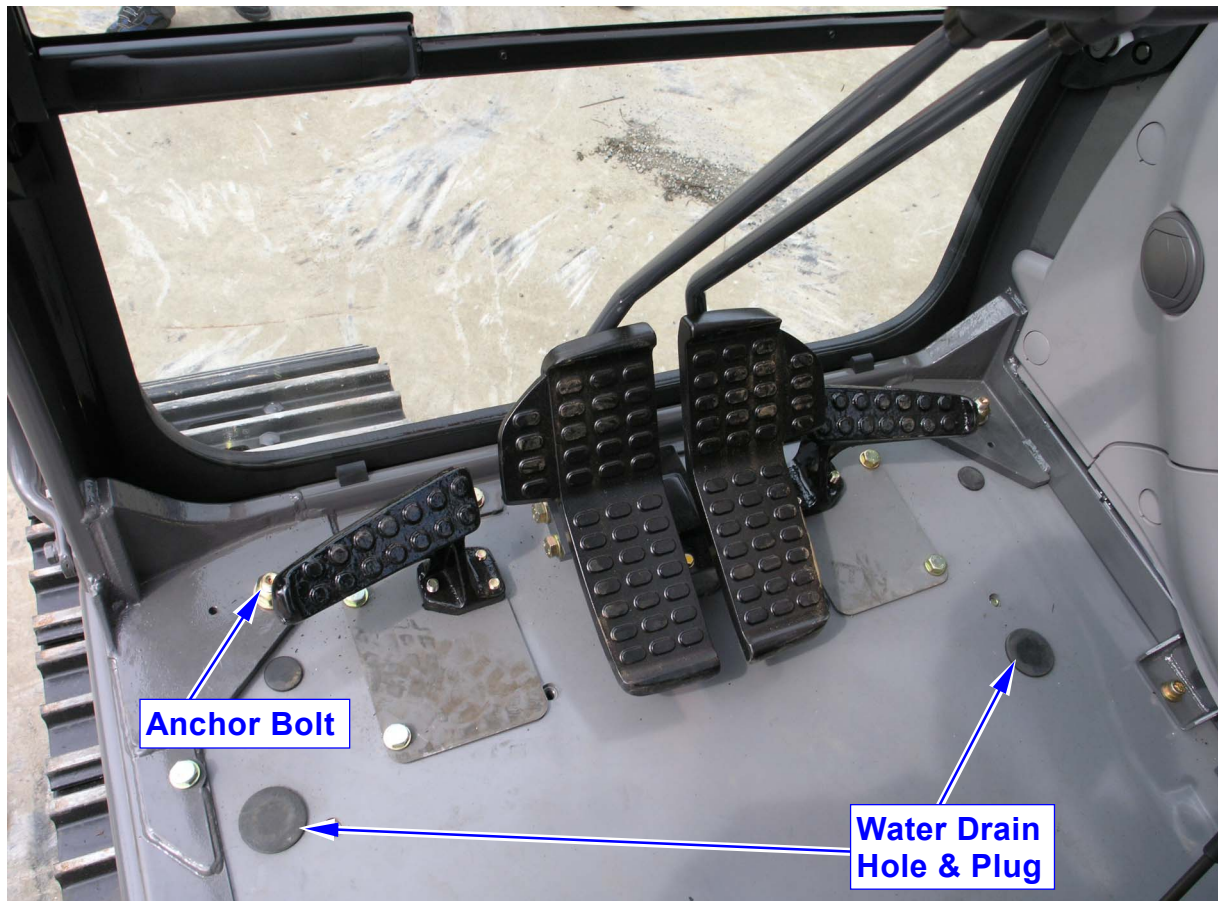

0682-011

EMERGENCY ENGINE STOP SWITCH

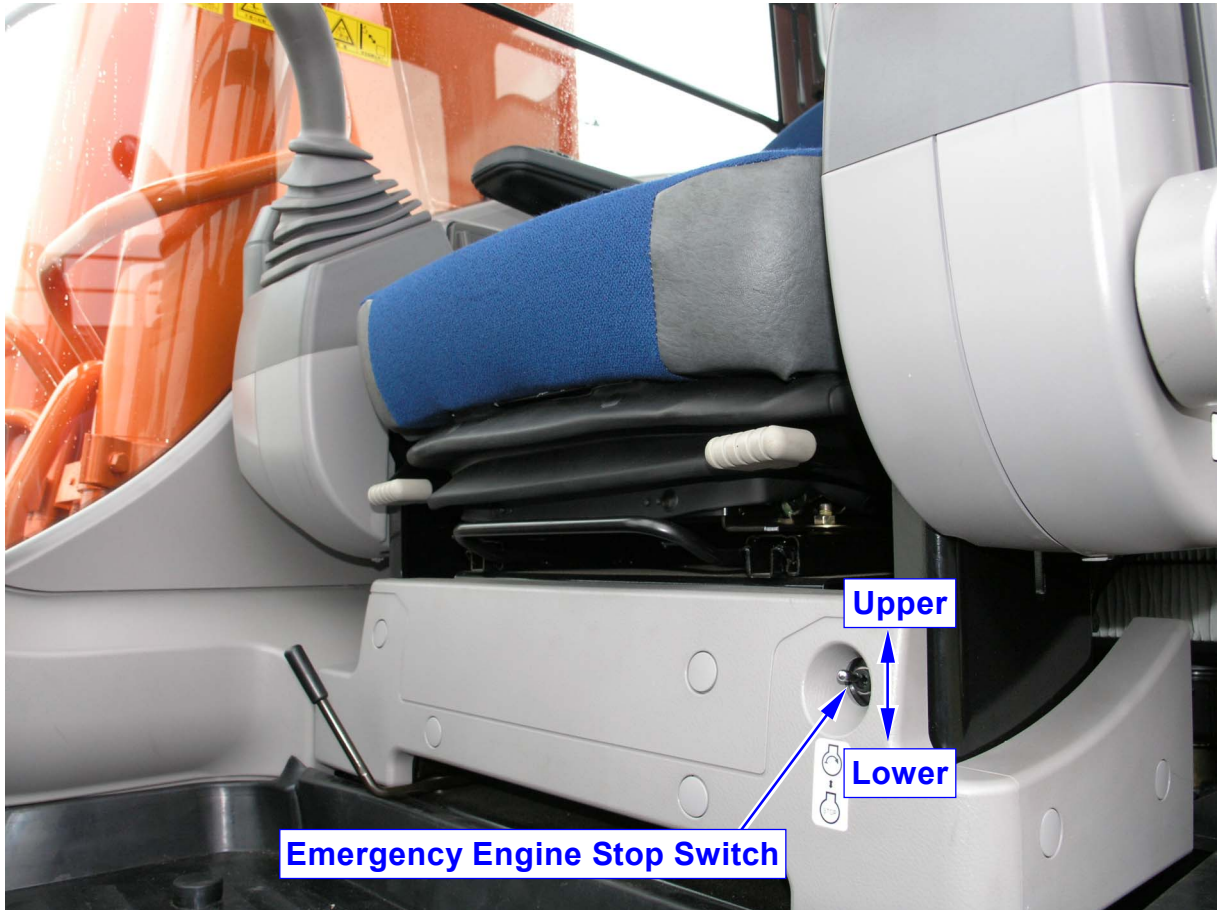

0682-012

MULTI-FUNCTION MONITOR



0682-013

Emergency Engine Stop Switch

- Switch Position
Upper Side : Engine Start
Lower Side : Engine Stop

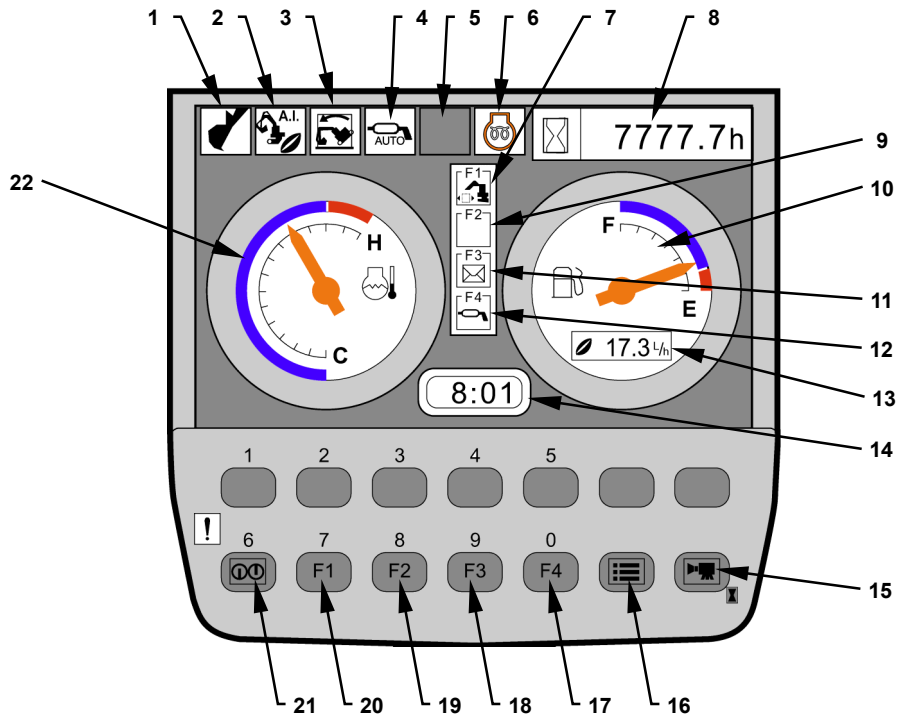

- | | | | |
|---|--|-----------------------------|--------------------------------|
| 1 - Work Mode Display | 7 - Work Mode Display | 13 - Fuel Consumption Gauge | 18 - Mail Selection (Optional) |
| 2 - Auto-Idle Display | 8 - Hour Meter | 14 - Clock | 19 - Auxiliary Selection |
| 3 - Overload Alarm Display (Optional) | 9 - Auxiliary | 15 - Back-Screen Selection | 20 - Work Mode Selection |
| 4 - Auto Lubrication Display (Optional) | 10 - Fuel Gauge | 16 - Menu | 21 - Return to Primary Screen |
| 5 - Auxiliary | 11 - Mail Display (Optional) | 17 - Auxiliary Selection | 22 - Coolant Temperature Gauge |
| 6 - Glow Display | 12 - Auto Lubrication Display (Optional) | | |

Rear Side Display on The LCD Monitor



Light on Monitor



SWITCH PANEL (RIGHT)



0682-014

SWITCH PANEL (LEFT)



012

Switch Panel (Right)

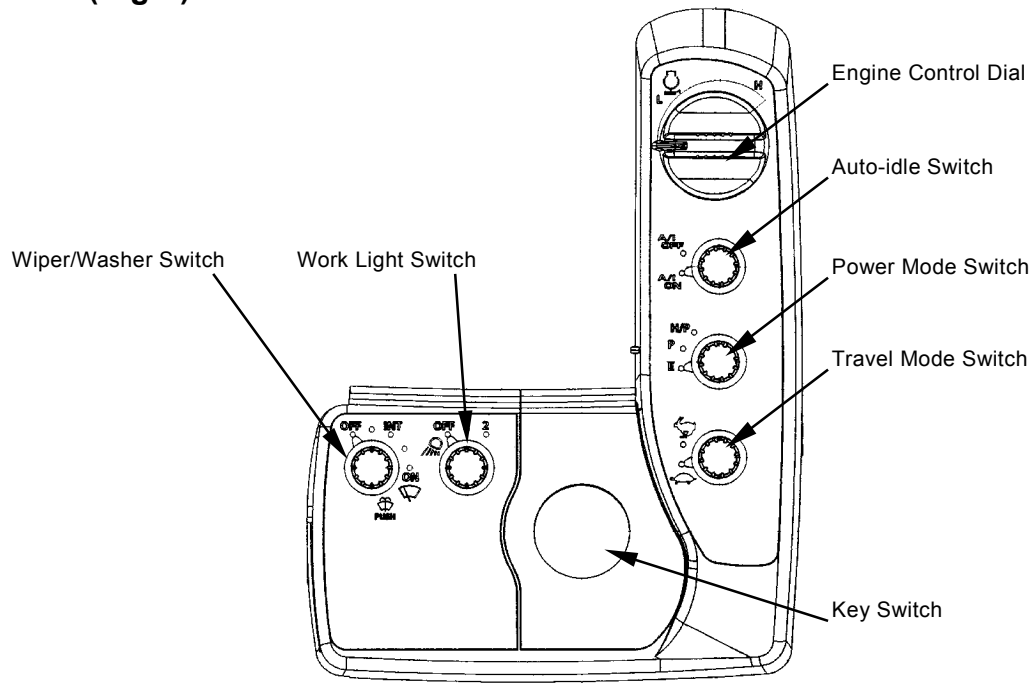

Switch Panel (Left)

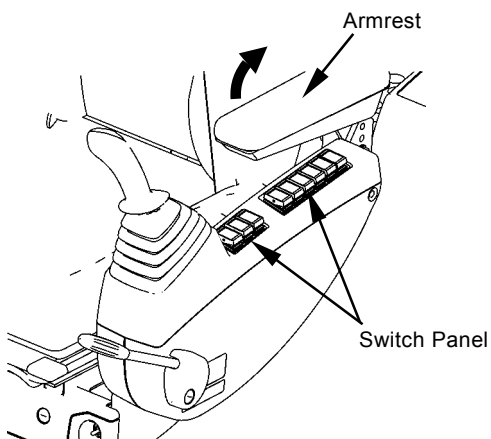

M1J1-03-001

PILOT CONTROL SHUT-OFF LEVER



013

PILOT VALVE & SHUT-OFF SWITCH

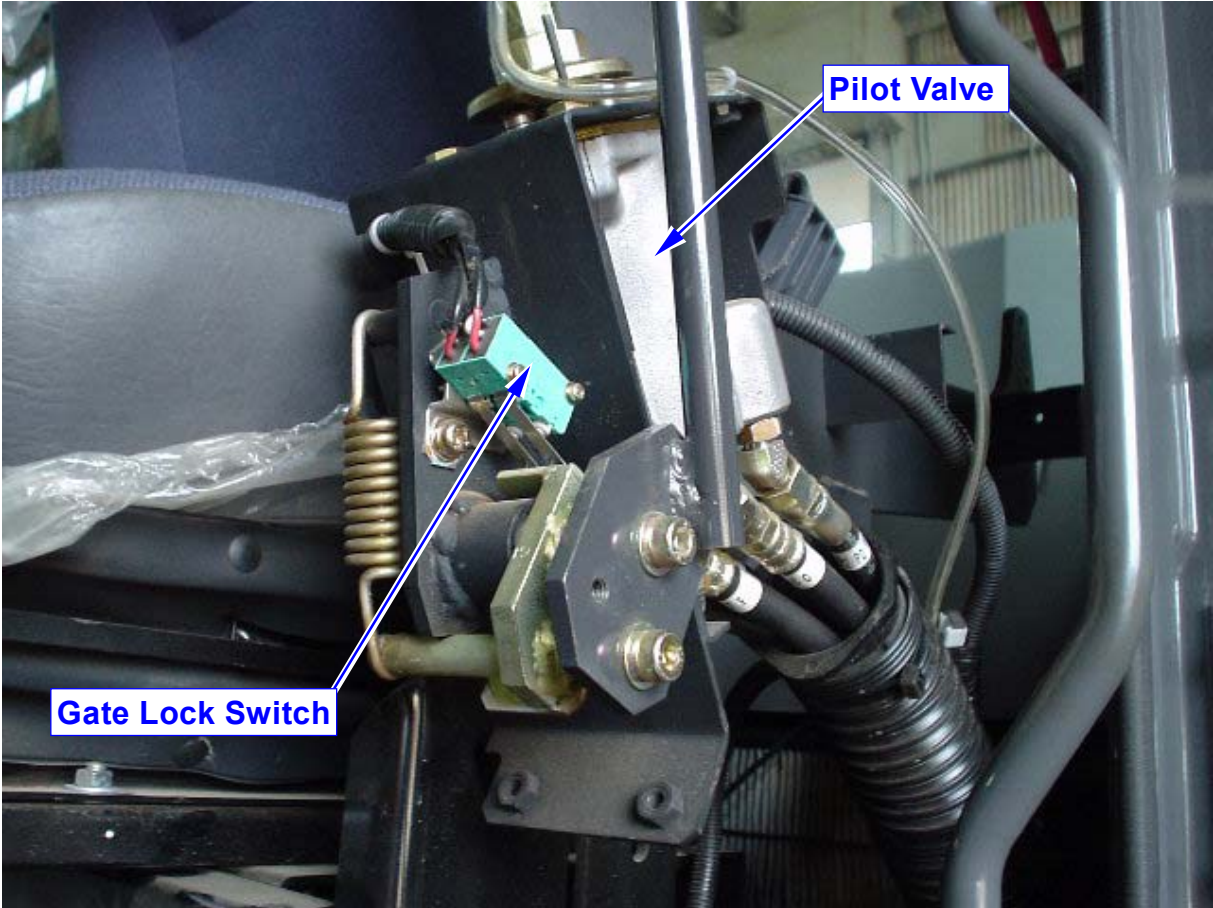

0682-017

Pilot Control Shut-off Lever

Lock valve was changed to the solenoid valve.
Purpose: The improvement of the air proof turn in the cab.

- Un Lock Position
Can be Operated (an Engine Doesn't Starter)
- Lock Position
Can't be Operated

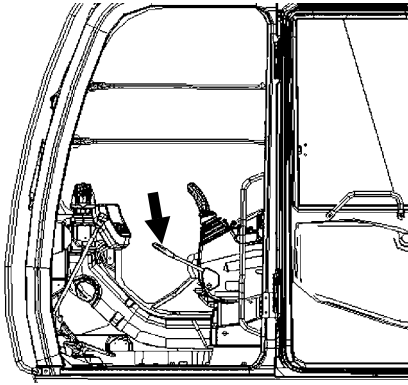

UN Lock Position

M1U1-01-024

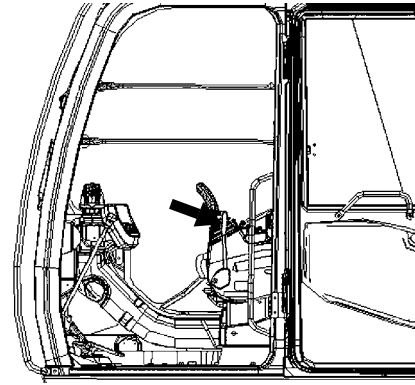

Lock Position

M1U1-01-025

REAR TRAY

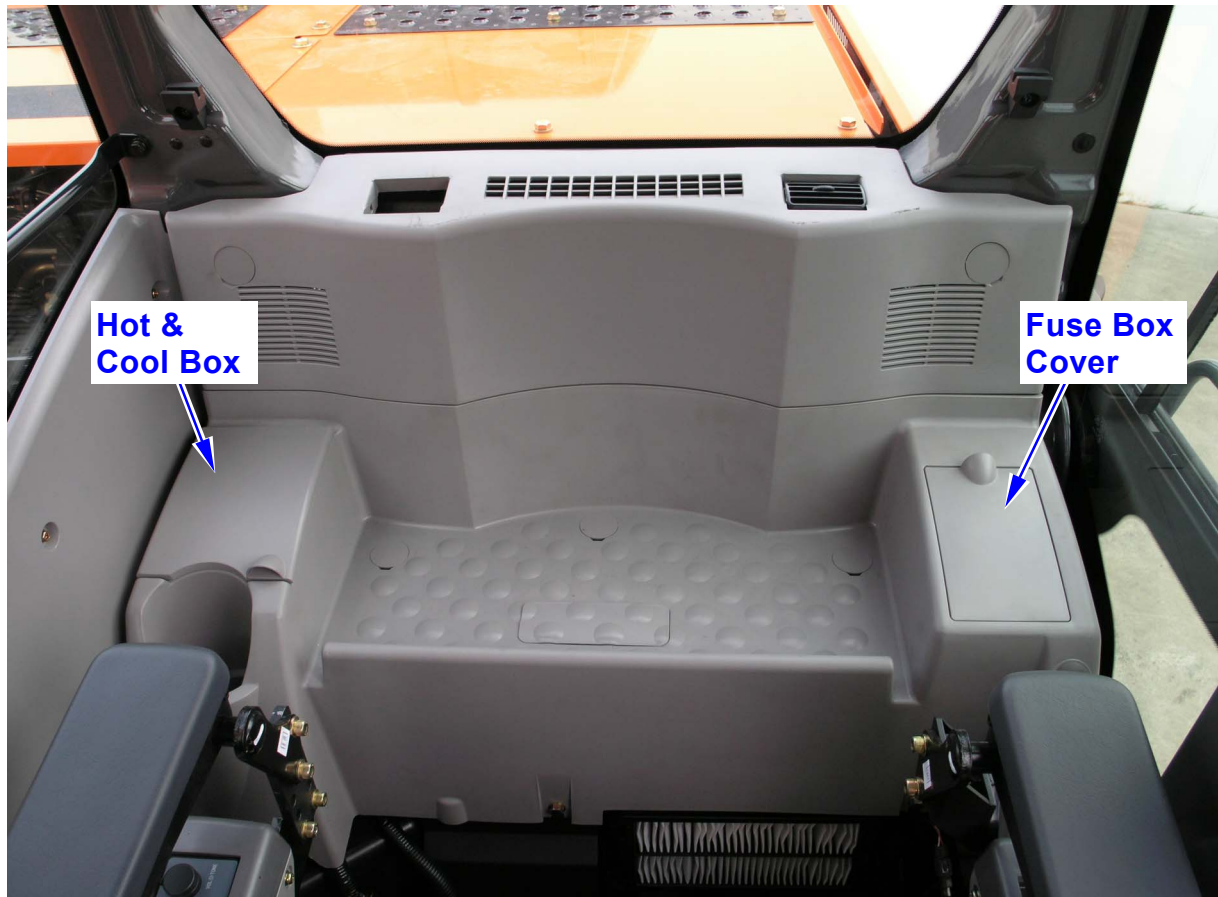

015

ELECTRICAL PARTS IN CAB

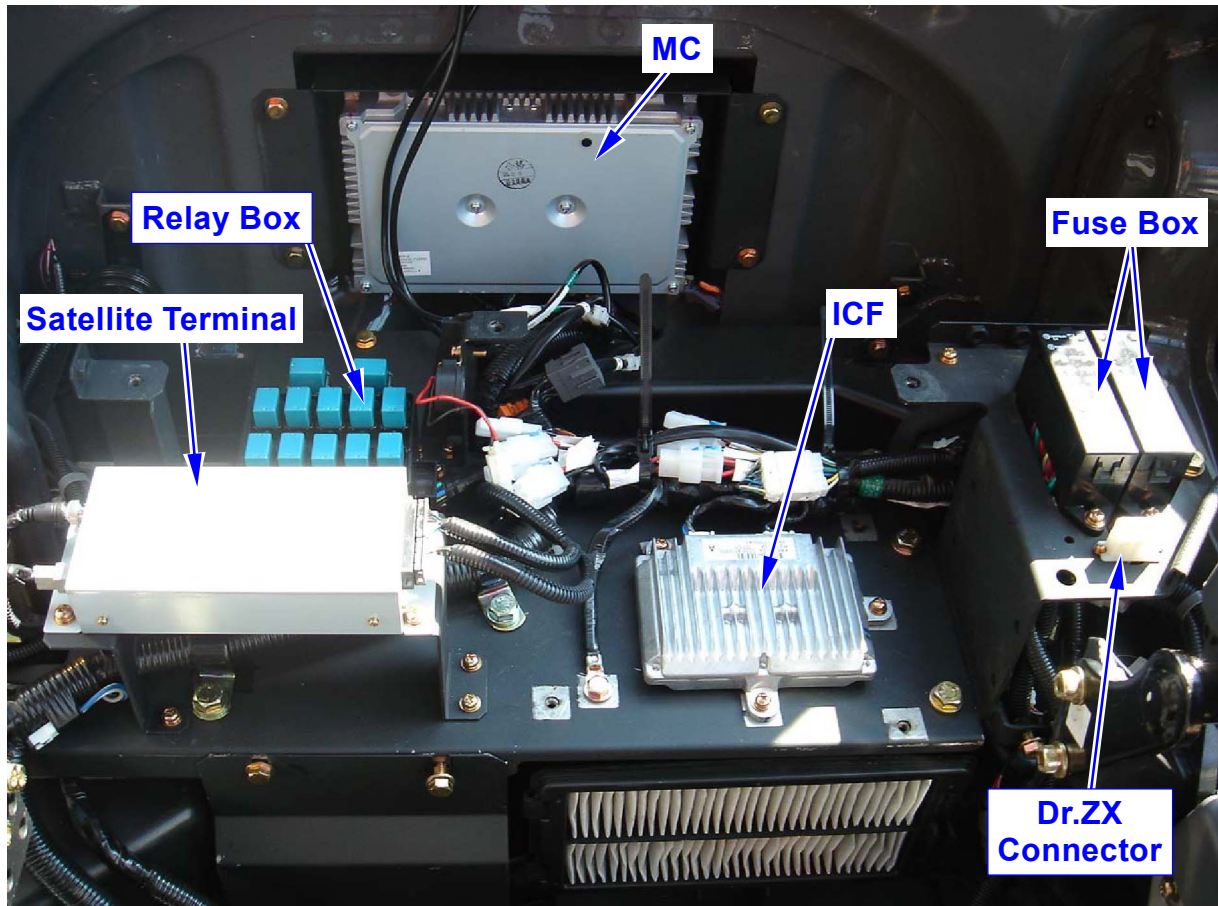

016

Fuse Box

- | | |
|----------------------|----------------------|
| 10- CONTROLLER
5A | 20- OPTION3
5A |
| 9- BACKUP
10A | 19- SW. BOX
5A |
| 8- ECM
30A | 18- POWER ON
5A |
| 7- LUBRICATOR
10A | 17- AIRCON
5A |
| 6- OPTION2
10A | 16- GLOW. R
5A |
| 5- OPTION1
5A | 15- AUXILIARY
10A |
| 4- SOLENOID
10A | 14- FUEL PUMP
5A |
| 3- HEATER
20A | 13- LIGHTER
10A |
| 2- WIPER
10A | 12- RADIO
5A |
| 1- LAMP
20A | 11- HORN
10A |

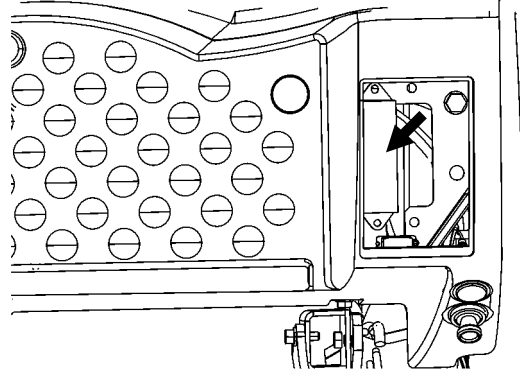

M1U1-01-026

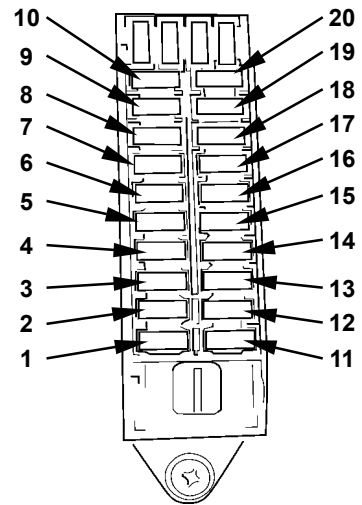

M1GR-01-003

ENGINE COMPARTMENT WITH COVER



016

ENGINE

ZX200-3	4HK1XYSA-01	114 kW/1800 min ⁻¹	122 kW/2000 min ⁻¹
ZX240-3	4HK1XYSA-01	127 kW/1900 min ⁻¹	132 kW/2000 min ⁻¹
ZX270-3	4HK1XYSA-03	136 kW/2000 min ⁻¹	142 kW/2000 min ⁻¹



017

ENGINE

- ManufacturerISUZU
- Model4HK1XYSA-02
- TypeDiesel, 4-Cycle, Water-Cooled, Direct Injection Type, Exhaust Turbo Charged Type.
- Cyl. No. Bore × Stroke.....4-115 mm × 125 mm (4.5 in × 4.92 in)
- Piston Displacement5193 cm³
- Rated Out Put 114 kW/1800 min⁻¹ (155 ps/1800 rpm)
HP Mode : 122 kW/2000 min⁻¹ (166 PS/2000 rpm)
- Compression Ratio..... 17.5
- Dry Weight478 kg

COOLED EGR SYSTEM SENSORS

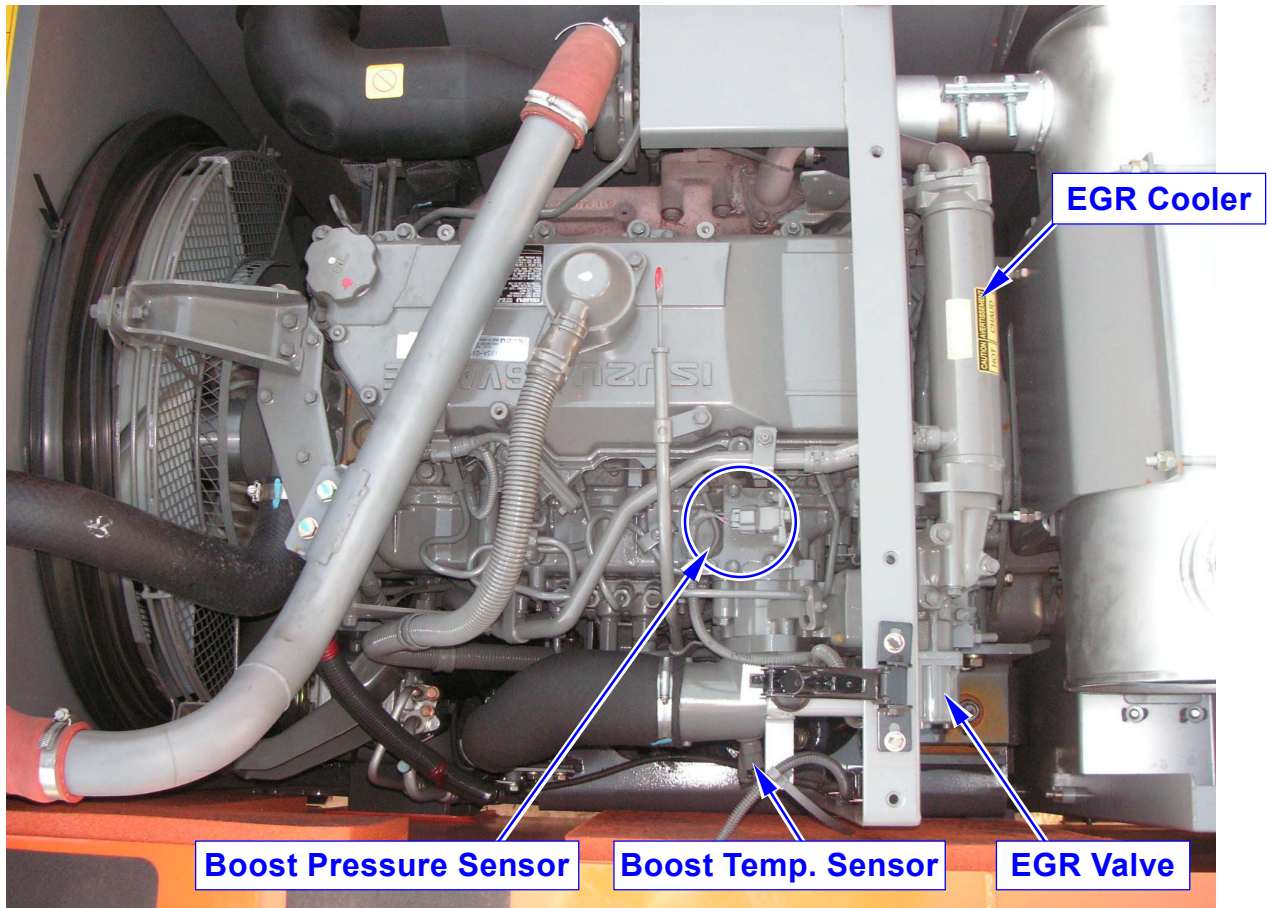

018

CRANK SPEED SENSOR & SENSORS

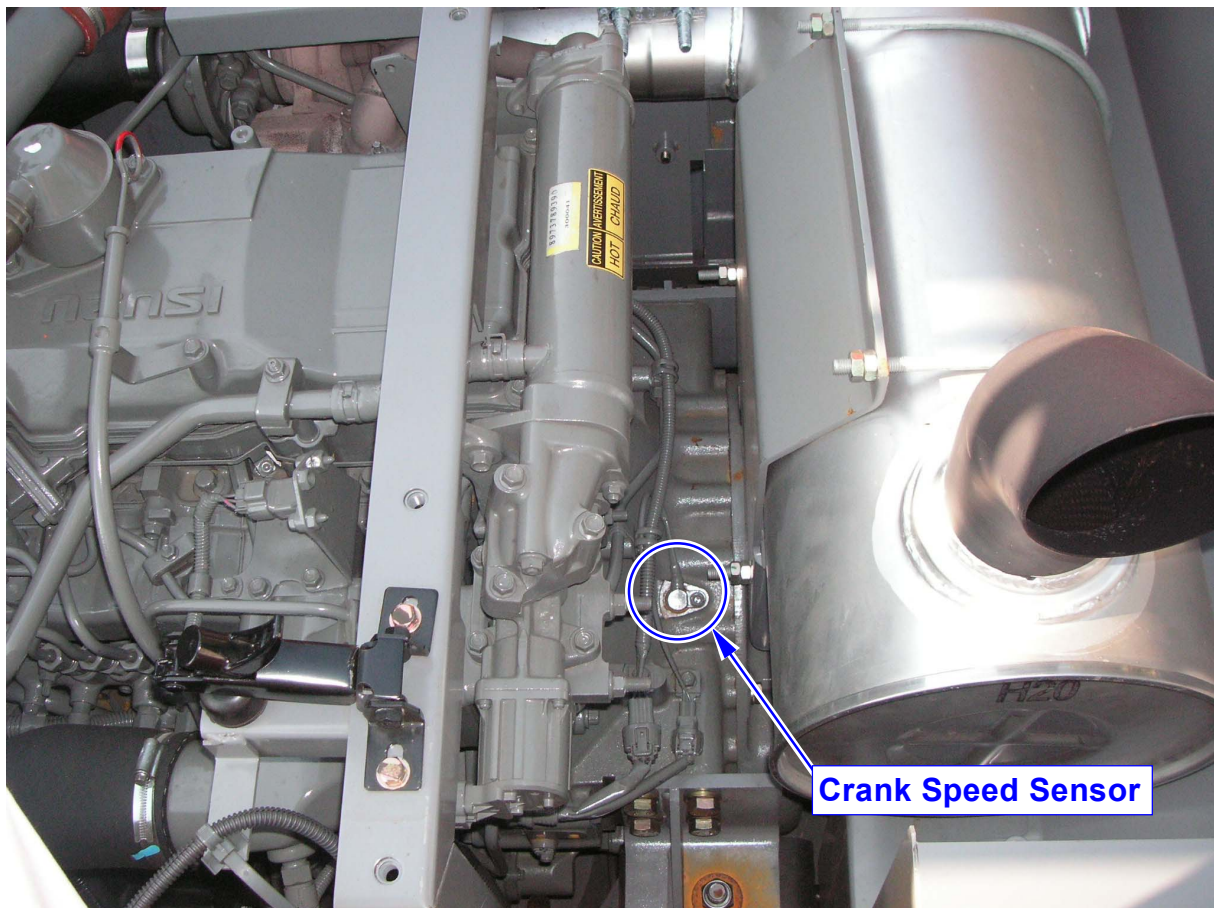

019

Cooled EGR (Exhaust Gas Re-Circulation) System.

- Exhaust gas recirculation system is abbreviated to EGR system. It recirculates parts of exhaust gas into intake manifold to mix an inert gas with intake air. This leads to lower the combustion temperature to limit emissions of nitrogen oxide. (Nox)

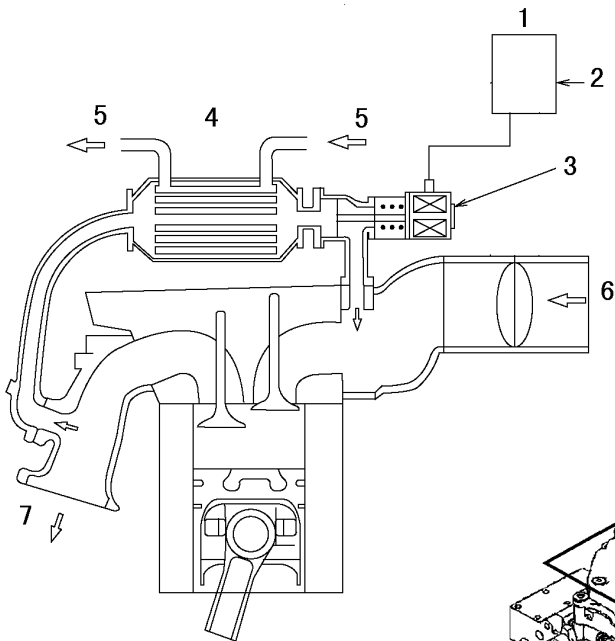

1. Engine Control Module (ECM)
2. Various Sensor Inputs
3. Exhaust Gas Re-circulation ((EGR) Valve)
4. EGR Cooler
5. Engine Coolant
6. Intake Air
7. Exhaust Gas

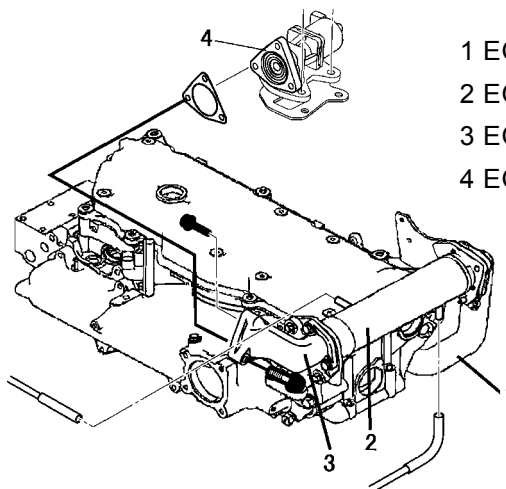

- 1 EGR Pipe
- 2 EGR Cooler
- 3 EGR Adapter
- 4 EGR Valve & REED VALVE

Sensors of Engine

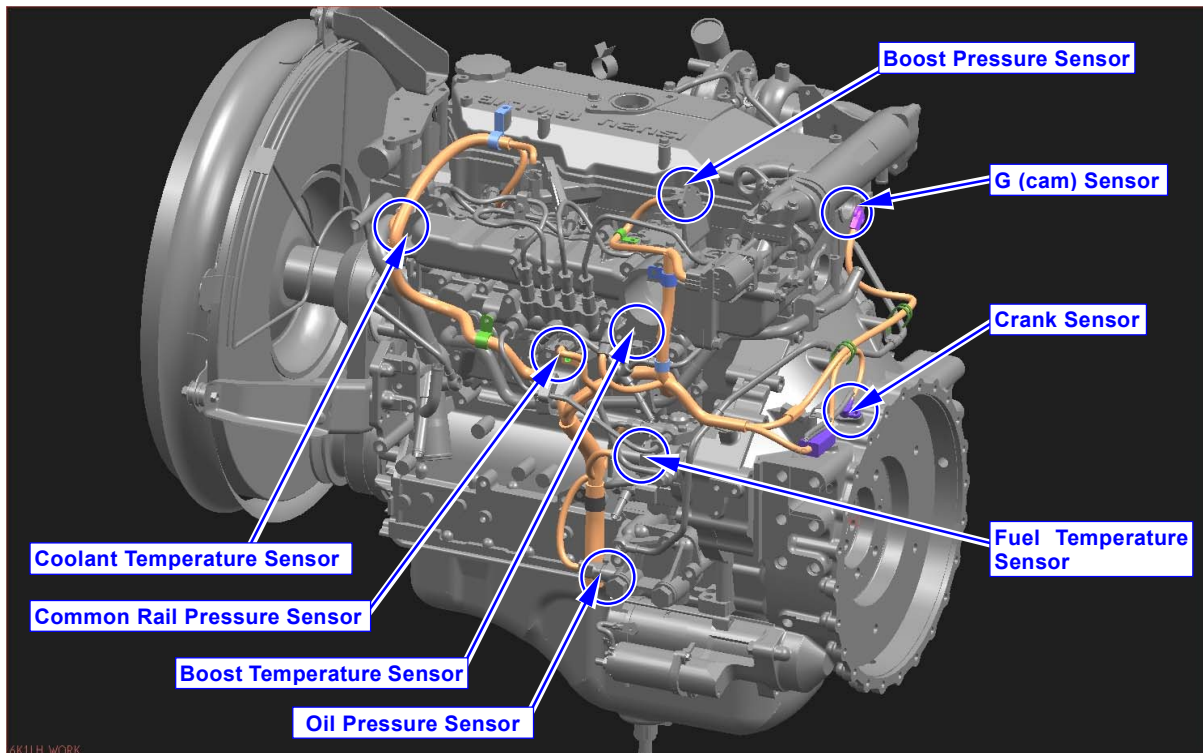

COOLANT TEMP. SENSOR

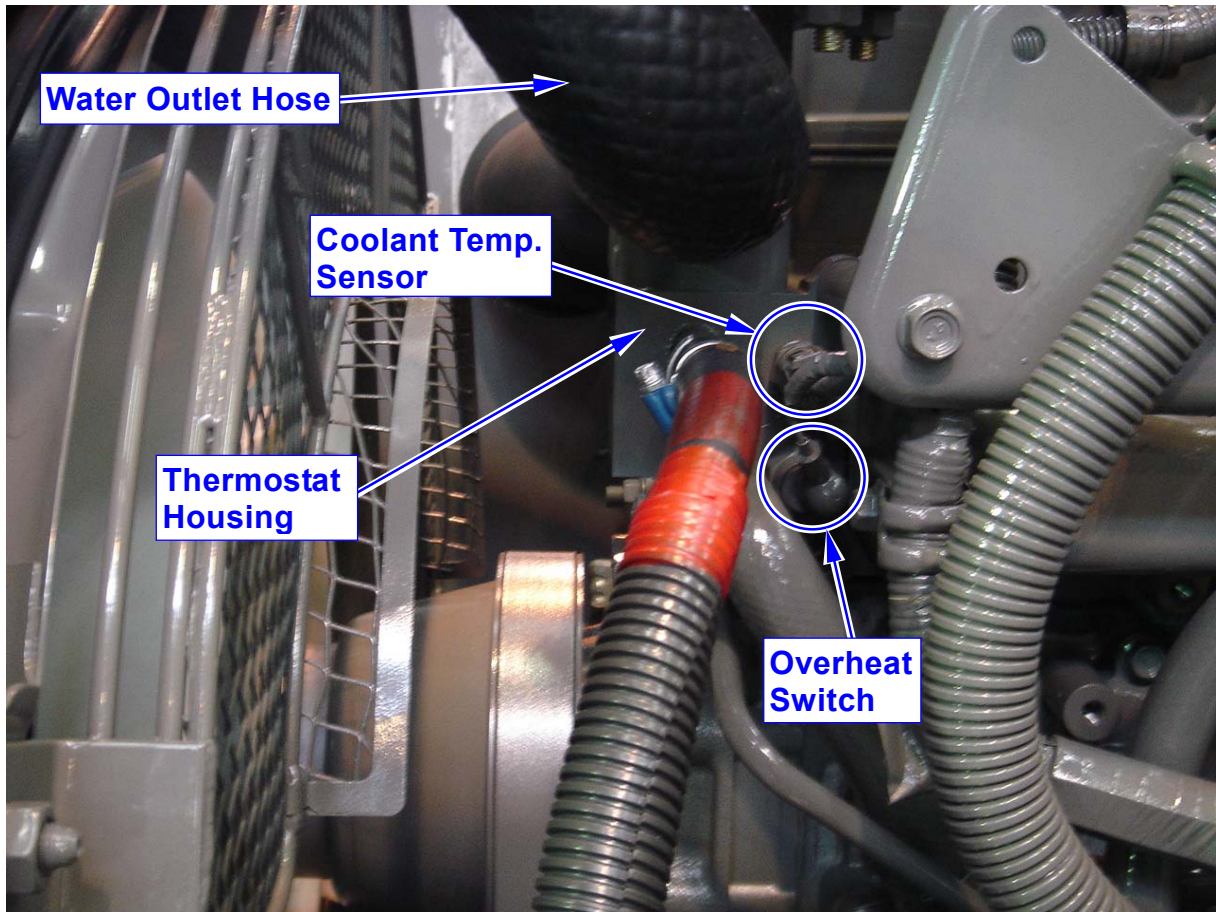

020

COMMON RAIL PRESSURE SENSOR

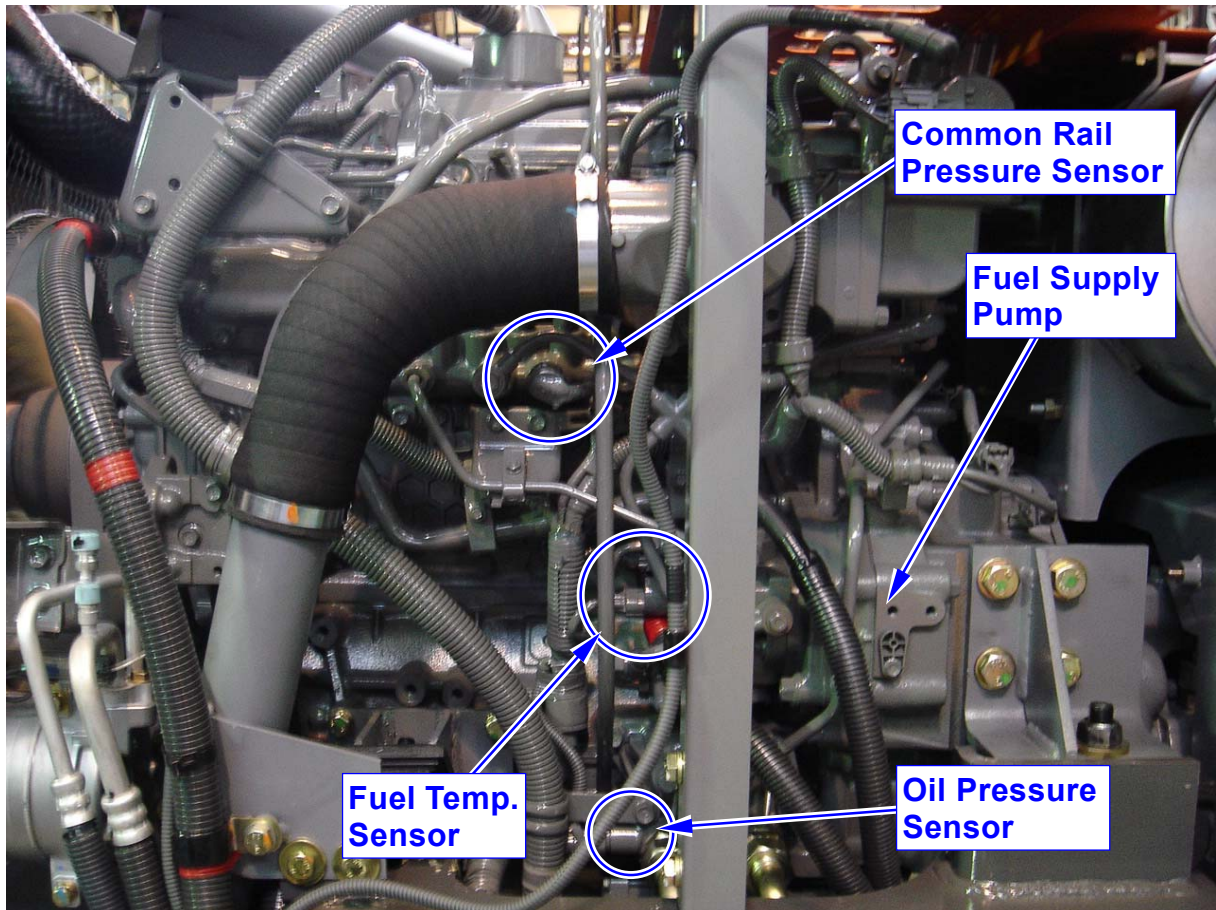

021

Common Rail System

- The common rail system uses a type of accumulation chamber called a rail to store pressurized fuel, and injectors that contain electronically controlled solenoid valves to inject the pressurized fuel into the cylinders.

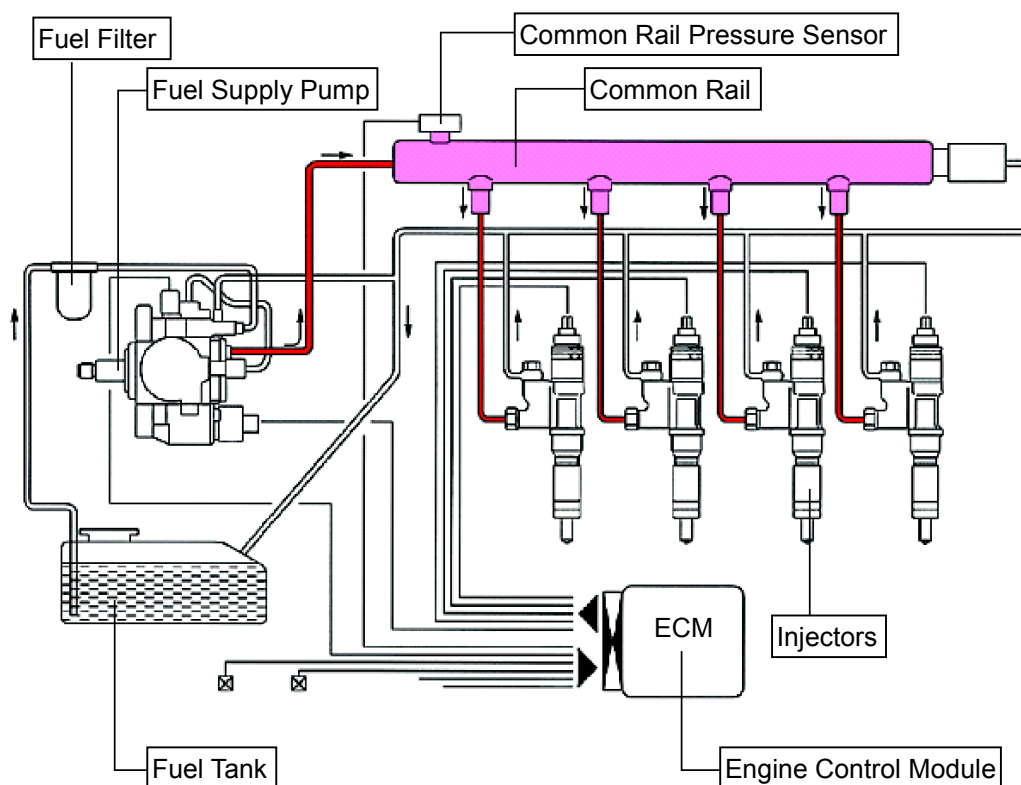

MAIN FUEL / PRE-FUEL FILTER & FUEL PUMP

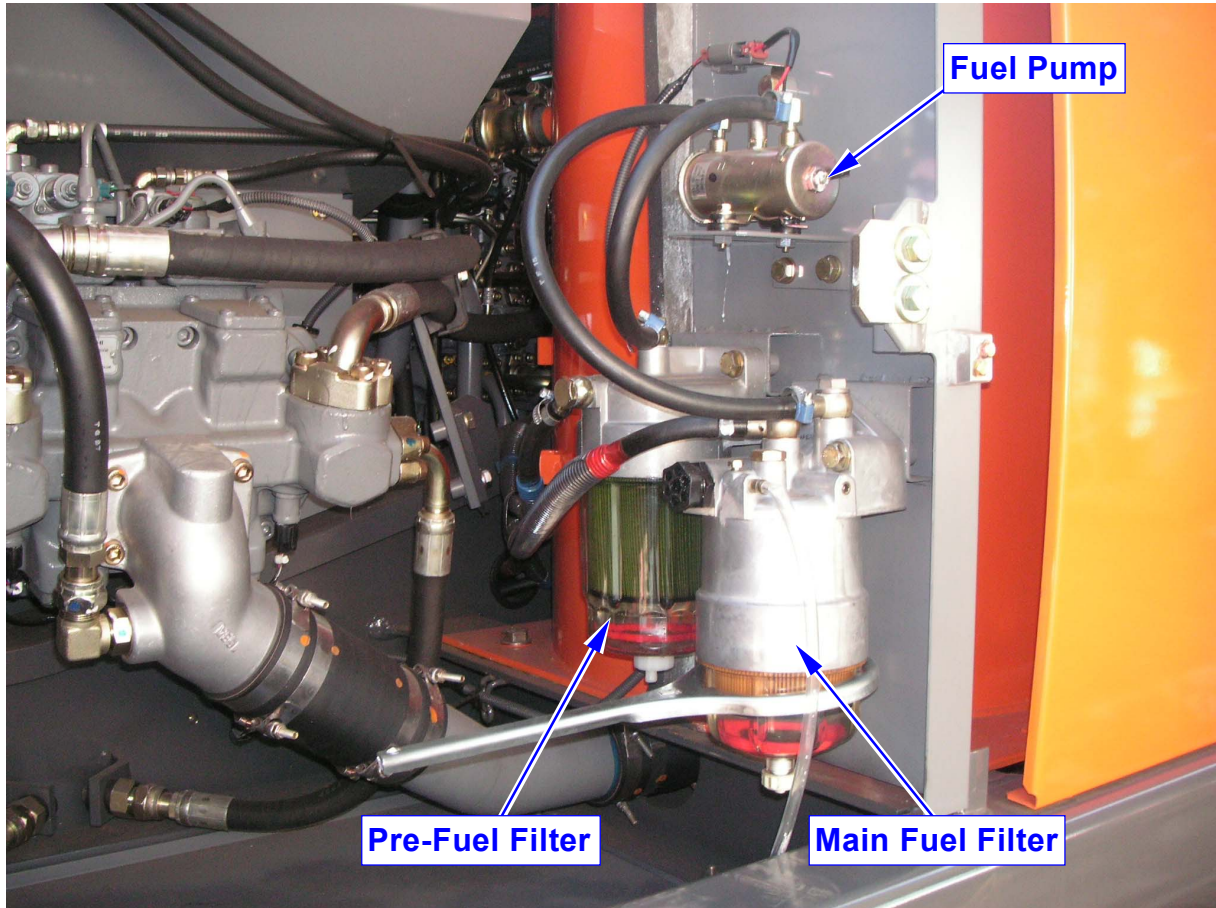

022

ENGINE OIL FILTER



023

Main Fuel Filter

- Replacement Interval : Every 500 hours.

Pre-Fuel Filter

- Replacement Interval : Every 500 hours.

Fuel Pump Strainer

- Clean Interval : Every 500 hours.

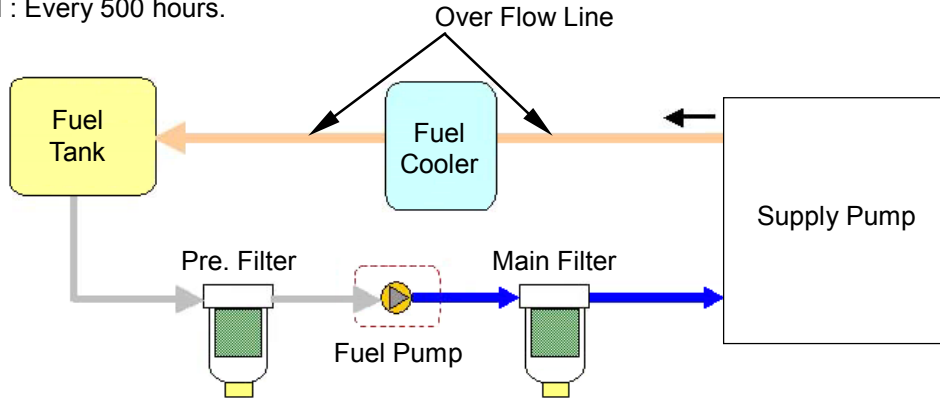

Type	Pre. Filter	Fuel Pump Strainer	Main Filter
ZX200-3~ZX330-3	17 μ 0.8 m ² W/Sedimenter	100 μ Reuseable	4 μ 0.54 m ² W/Sedimenter
ZX200	20 μ 0.48 m ² (Option)	–	20 μ 0.21 m ²

Engine Oil Filter (1 Pc)

- Replacement Interval : Every 500 hours

ENGINE OIL DRAIN



024

ENGINE OIL DRAINER



025

Engine Oil

- Change Interval : Every 500 hours
Change 250 hours, if the Content of Sulfur of Fuel is 2000 ppm or more.
- Engine Oil Capacity : ZX200-3, ZX270-3 23.0 L
ZX330-3 41.0 L
- Recommend Engine Oil
Supper WideDH-1 10W30 (-20 °C to 30 °C)
Supper WideDH-1 15W40 (-15 °C to 45 °C)

1. Remove cap from oil pan drain valve. Install drainer to the drain valve.
2. Screw drainer into drain valve, Drain valve will be opened to drain oil.
3. After all oil has been drained, remove drainer. Install cap to drain valve.

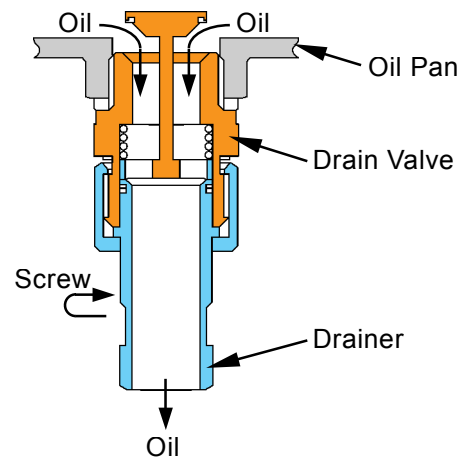
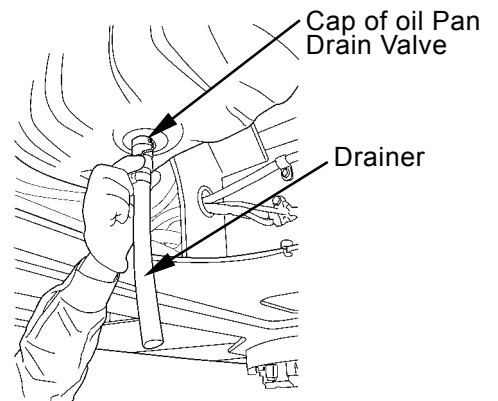

UTILITY SPACE



026

ENGINE CONTROL MODULE (ECM)

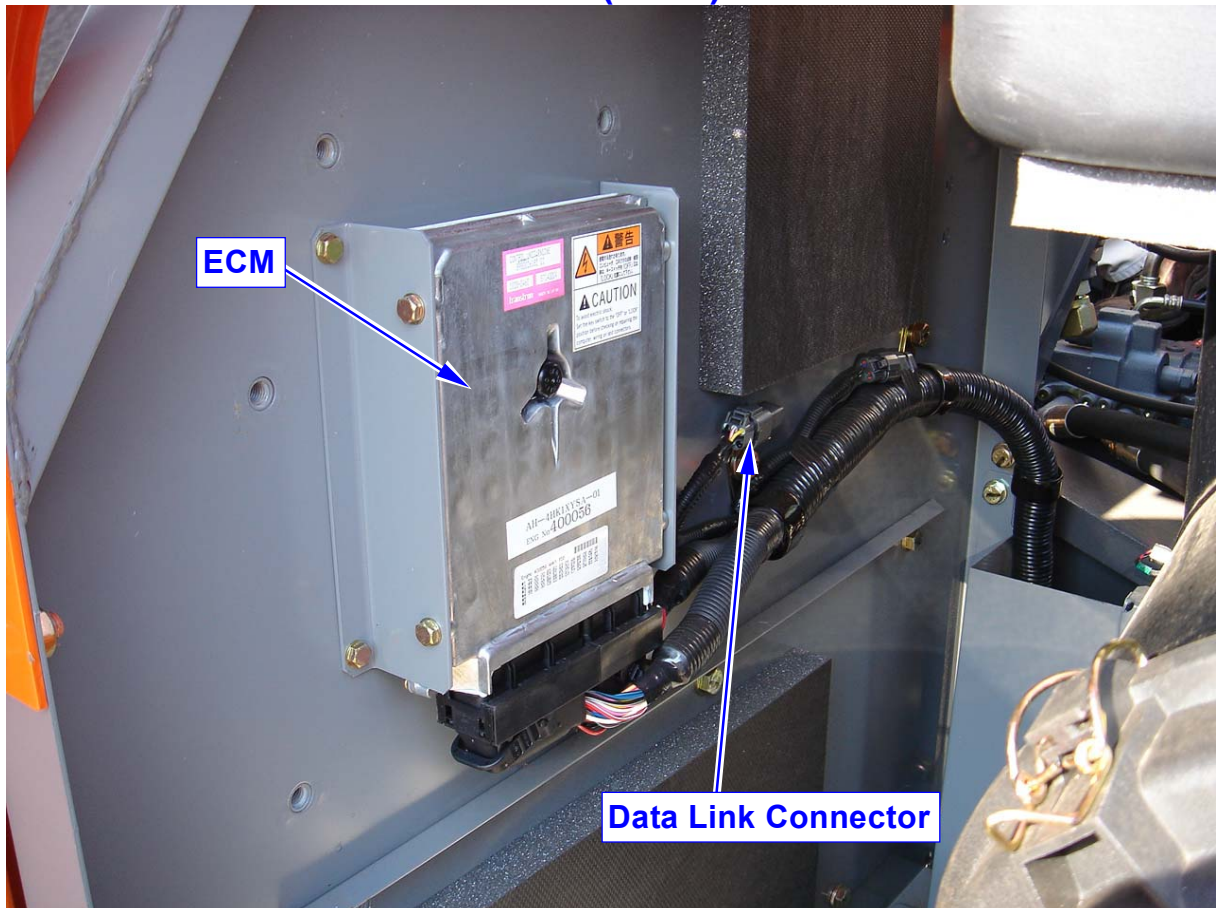

027

ECM (Engine Control Module)

- ECM (Engine Control Module)

The ECM controls flow rate of the Supply Pump and energization timing and energization duration of the Injector in order to achieve most appropriate injection pressure, injection time and injected fuel amount in response to signals sent from sensors mounted on the engine or main body.

The ECM also controls open/close of the EGR Valve.

AIR CLEANER AND ELEMENT



028

AIR CLEANER RESTRICTION SWITCH

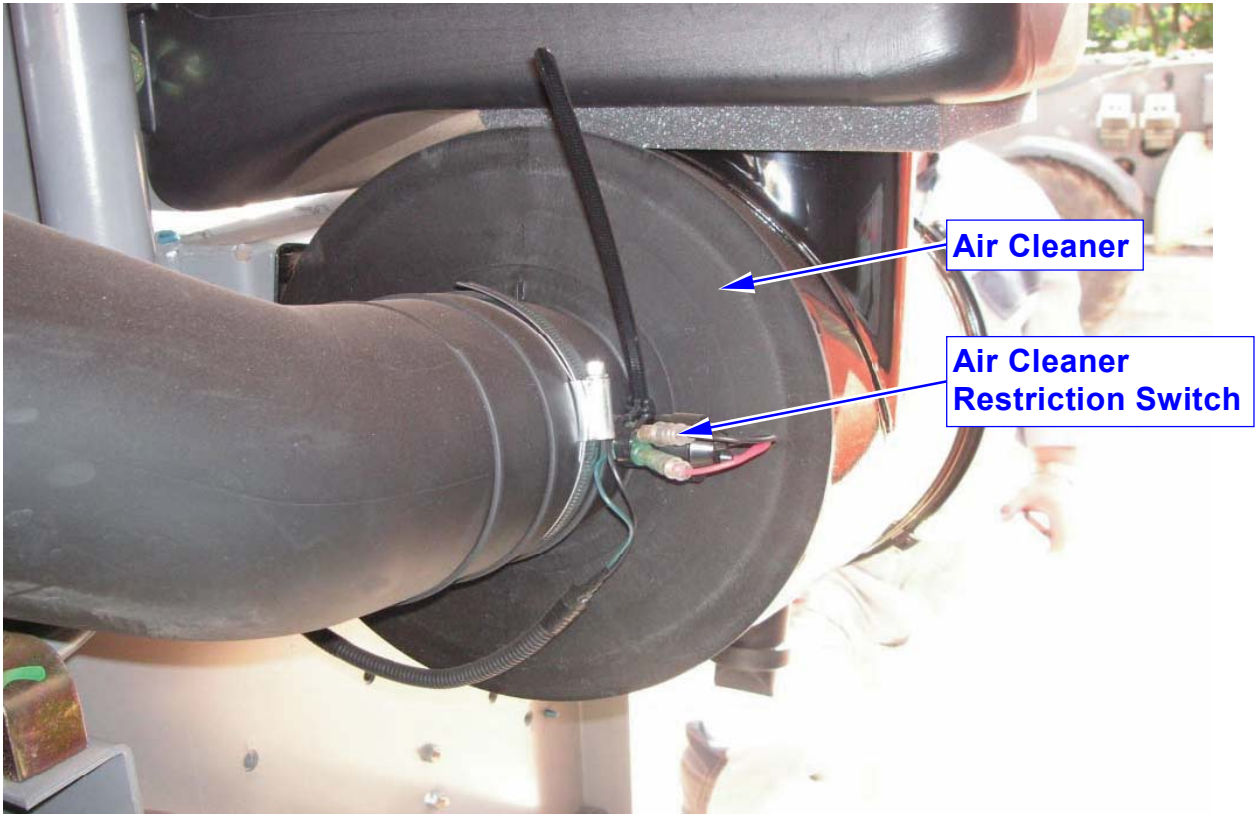

029

Air Cleaner Outer and Inner Element

- Cleaning Interval: Every 250 hours or when the restriction indicator comes ON.
- Replacement: After cleaning 6 times or 1 year.

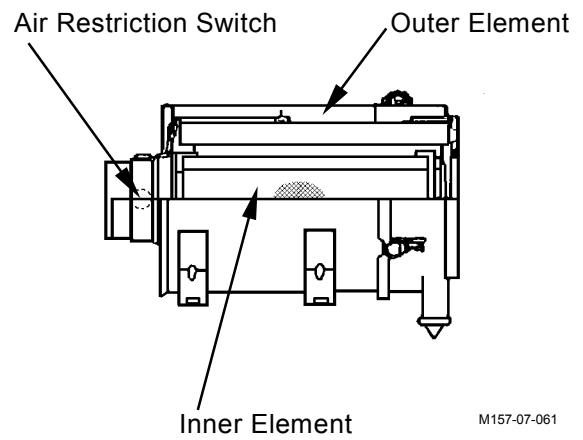
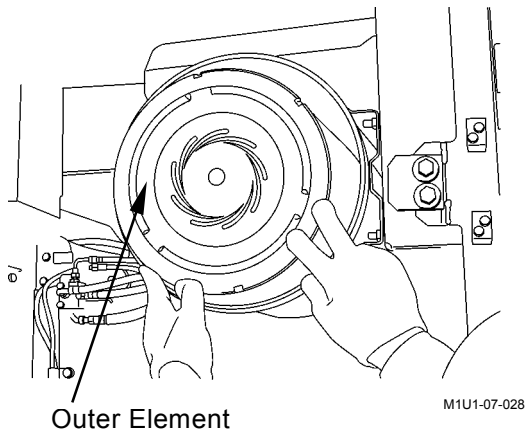

ATMOSPHERIC PRESSURE SENSOR

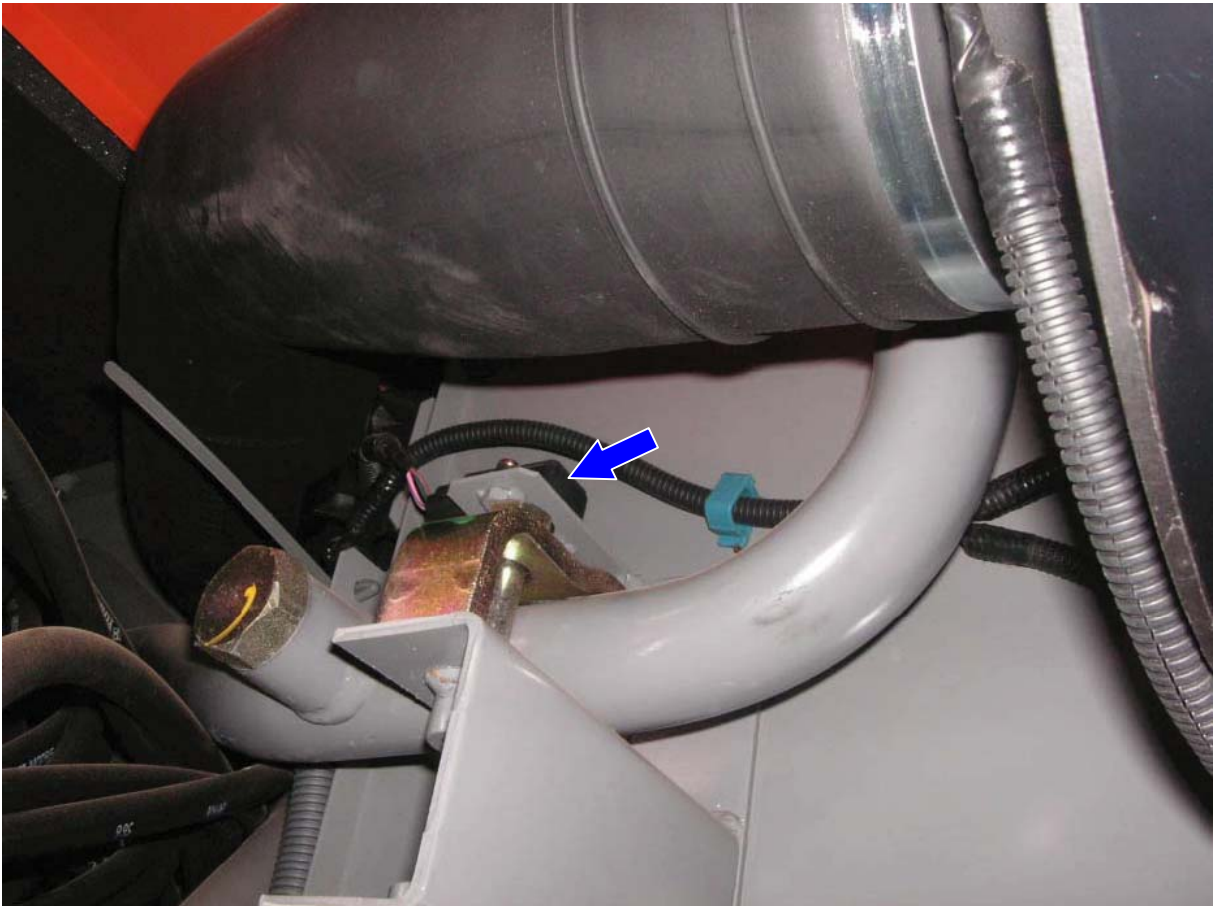

030

INTAKE AIR TEMPERATURE SENSOR

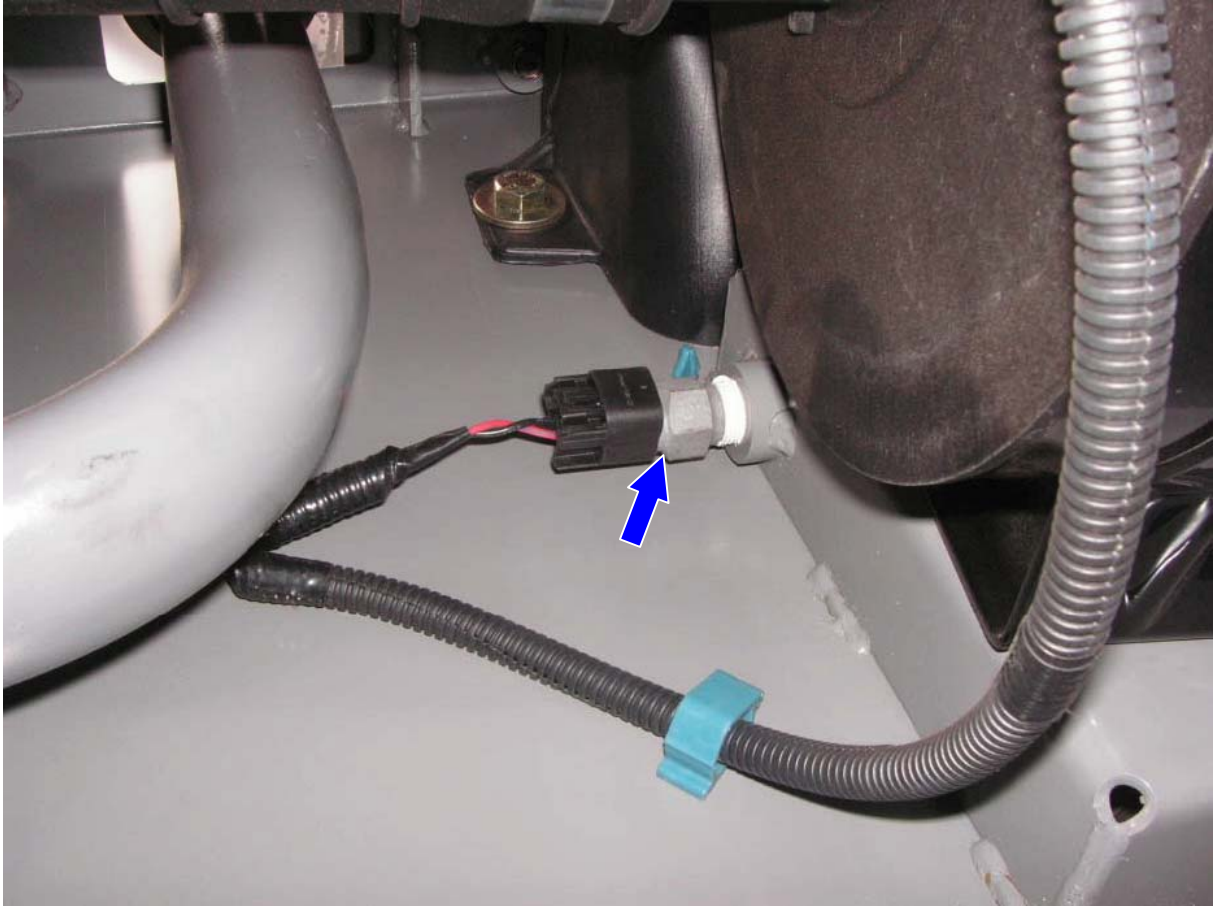

031

COOLING SYSTEM (INTER COOLER AND RADIATOR, OIL COOLER)

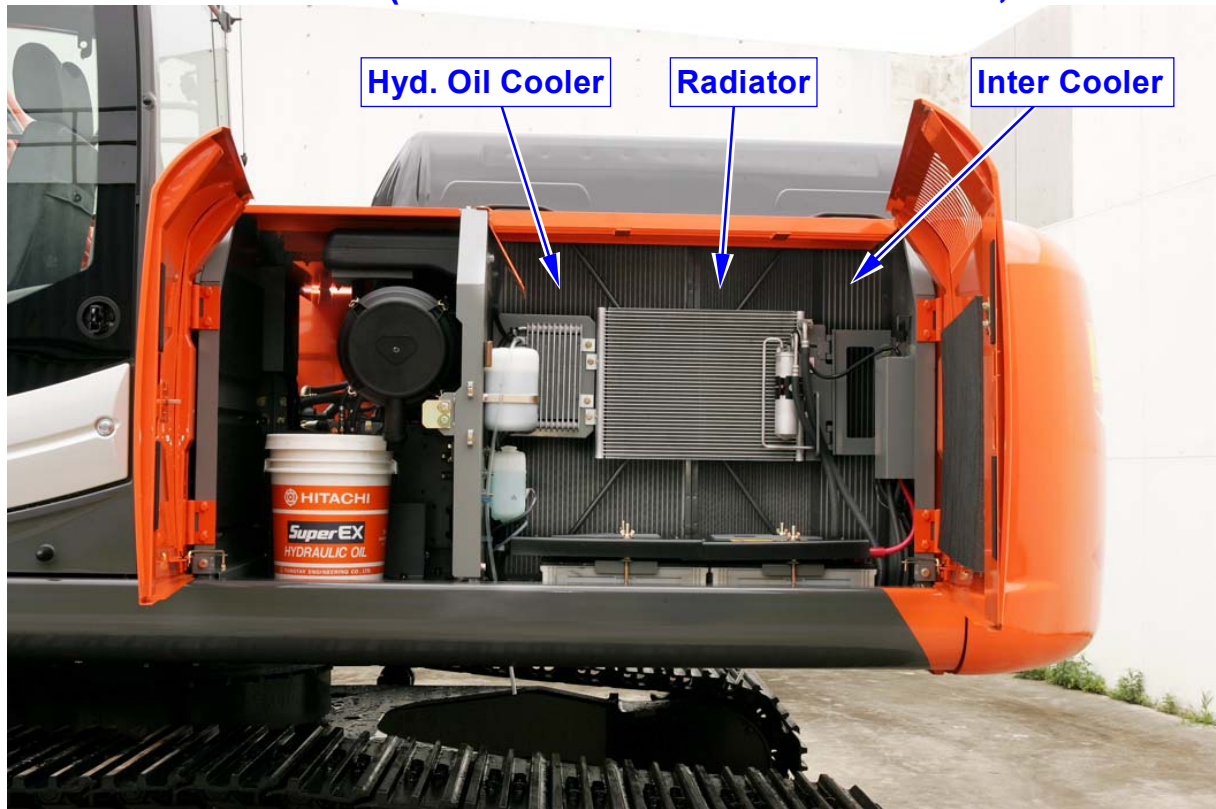

032

AIR CONDITIONER CONDENSER AND FUEL COOLER



033

Radiator

- Type Parallel Type
- Capacity 6.3 L

Intercooler

- Capacity 8.0 L

Oil cooler

- Capacity 10 L

Change Coolant Interval : Every Twice a Year (26 L)

Clean Interval : Every 500 hours

Air Conditioner Condenser

- Refrigerant 134 a
- Cooling Ability..... 19.3 MJ/h (4600 kcal/a)
- Cooling Air Volume..... 550 m³/h or More

Fuel Cooler

- Core Type..... Wavy Fin
- Capacity 0.2 L

BATTERY AND RELAYS

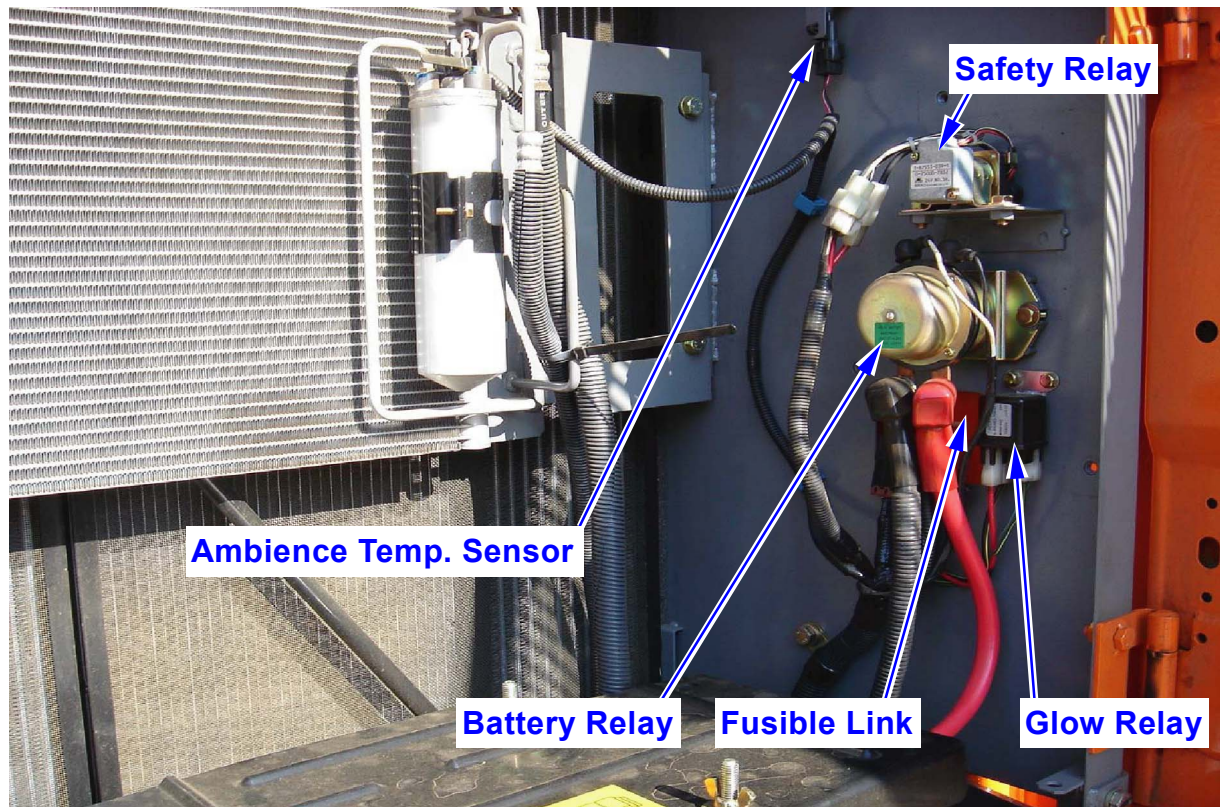

034

PUMP COMPARTMENT



035

Pump Device

- Drive Gear Raito Engine 1, Pilot Pump 1

Pump Transmission

- Oil Level Check Every 250 hours
- Change Oil every 1000 hours
- Oil Capacity 1.0 L (ZX200-3/270-3)
1.4 L (ZX330-3)

PUMP DEVICE

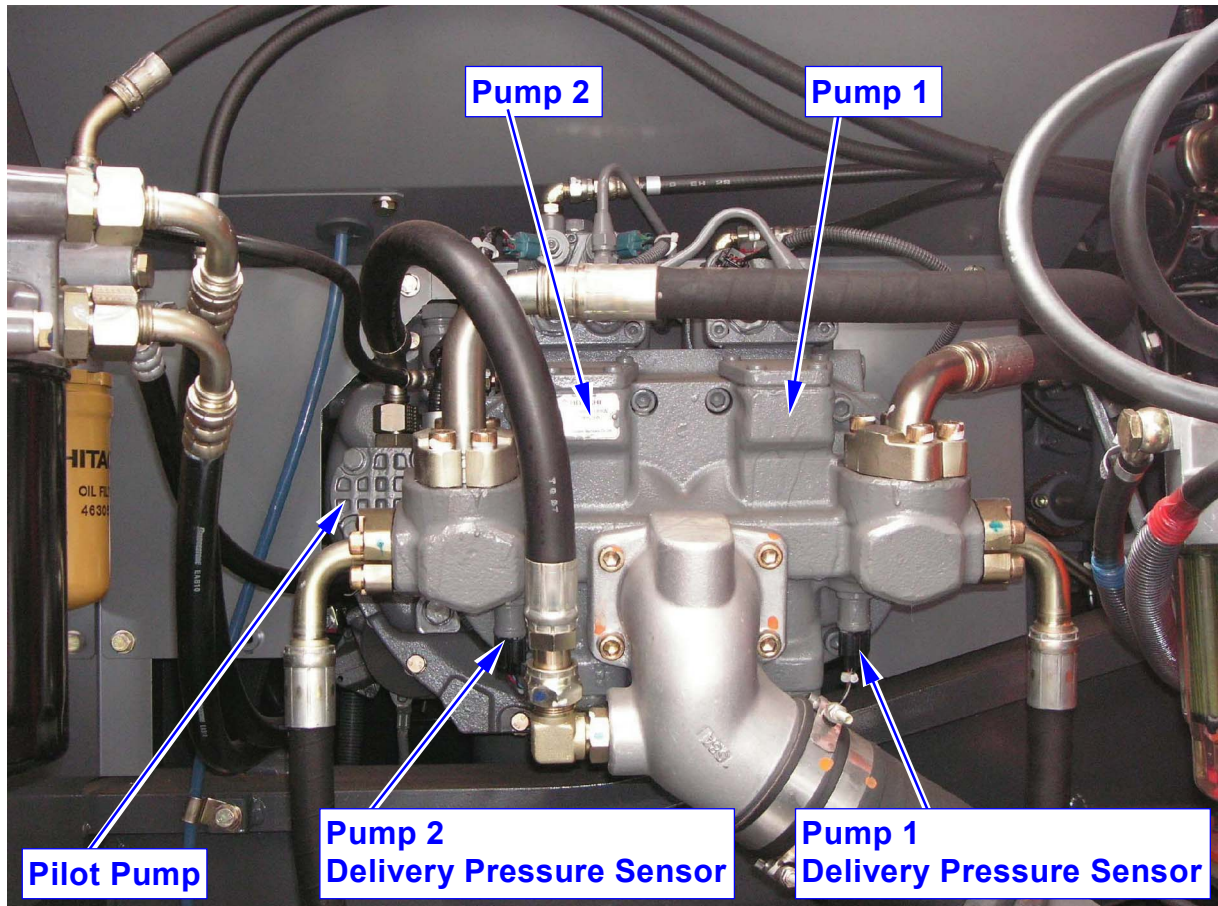

036

PUMP REGULATOR

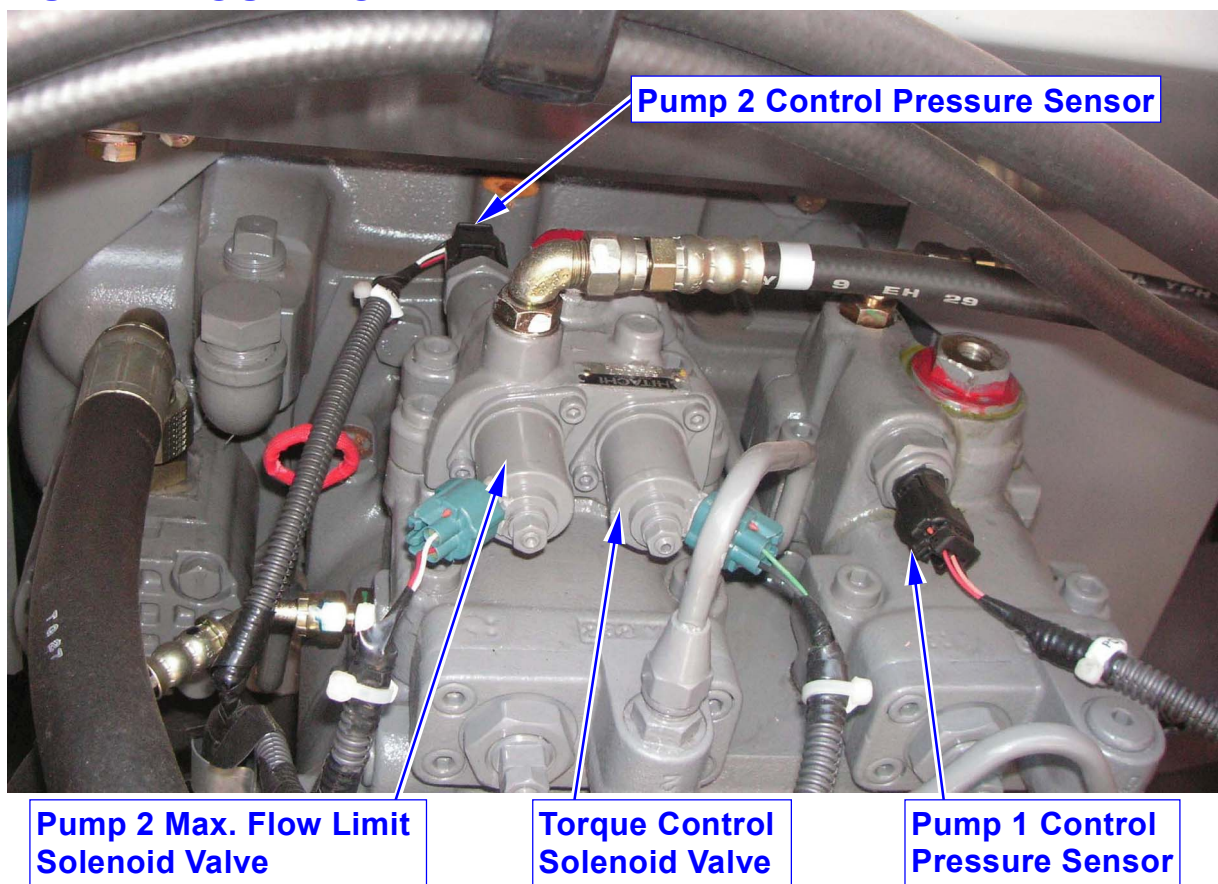

037

Main Pump 1. 2.

- Type Bent Axis Type Variavle Displacement Axial Plunger Pump.
- Max. Flow Rate 212 L/min (56 us gpm) × 2 (ZX200-3)
216 L/min (57 us gpm) × 2 (ZX240-3)
227 L/min (59.9 us gpm) × 2 (ZX270-3)

Pilot Pump

- Type Fixed Displacement Type Gear Pump.
- Max. Flow Rate 31.9 L/min.
HP Mode : 35.3 L/min (ZX200-3)
- Mode FS 11/16.8

Regulator

- Type Hydraulic Pressure Operated Type

PILOT FILTER

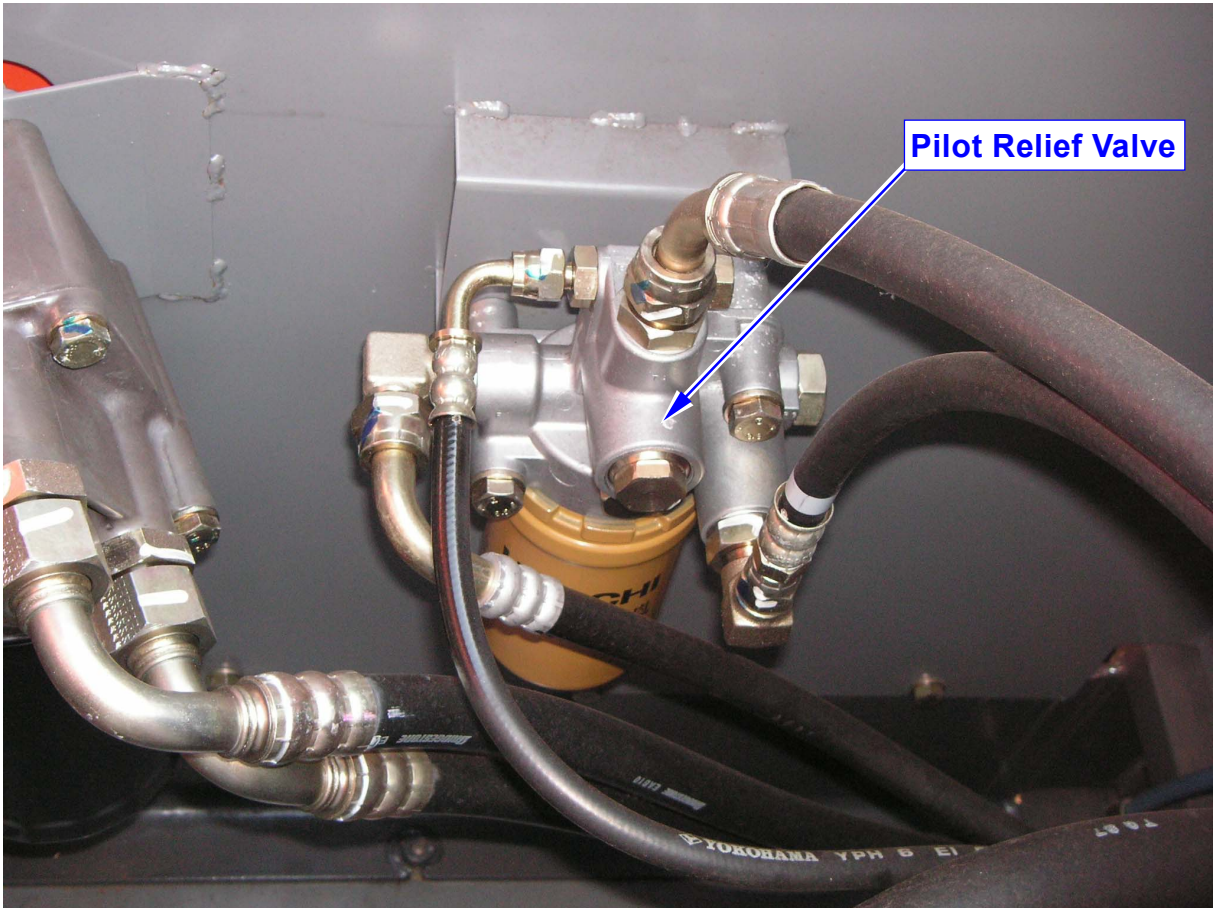

038

MAIN COMPONENT LAYOUT

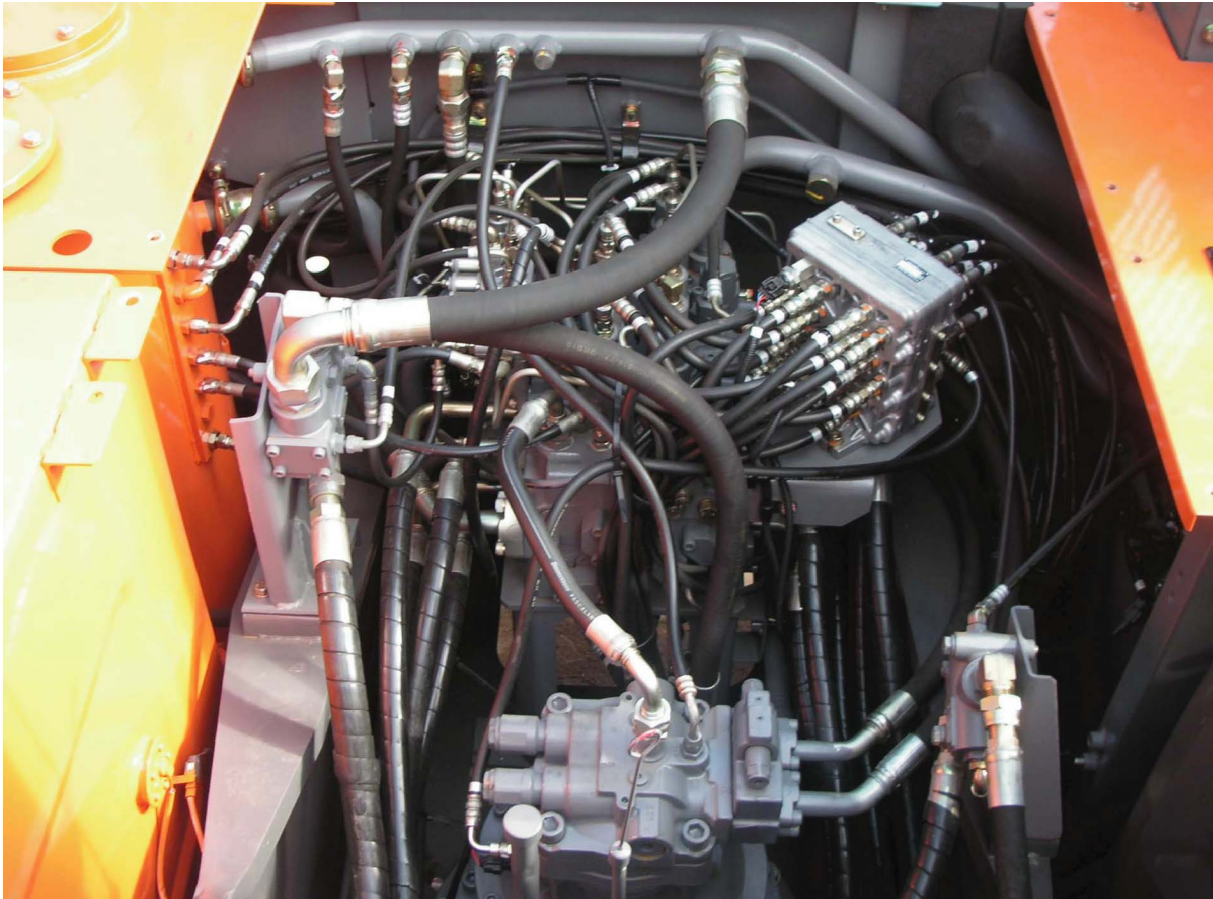

039

Pilot-Filter

- Replacement Interval : Every 1000 hours

CONTROL VALVE

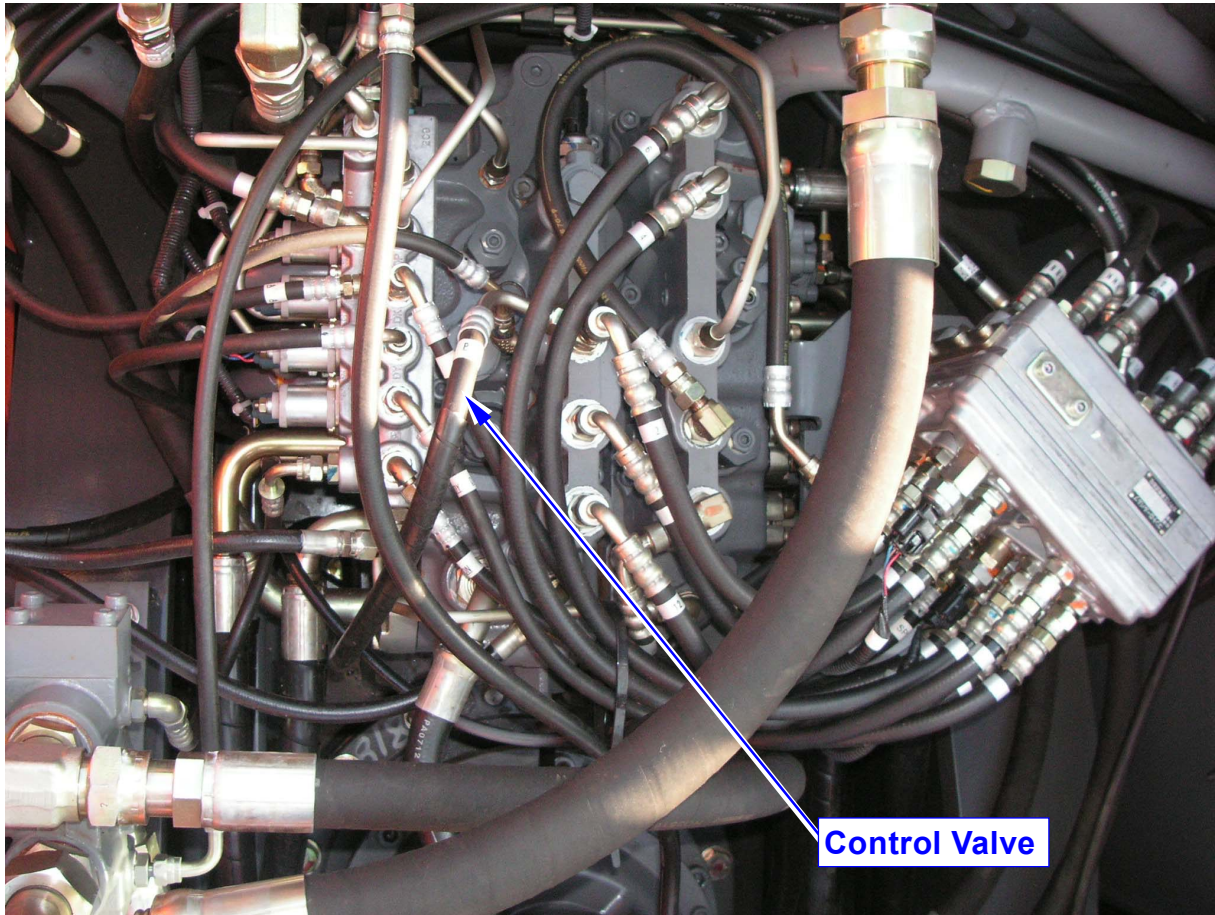

Control Valve

040

MAIN AND OVERLOAD RELIEF VALVE

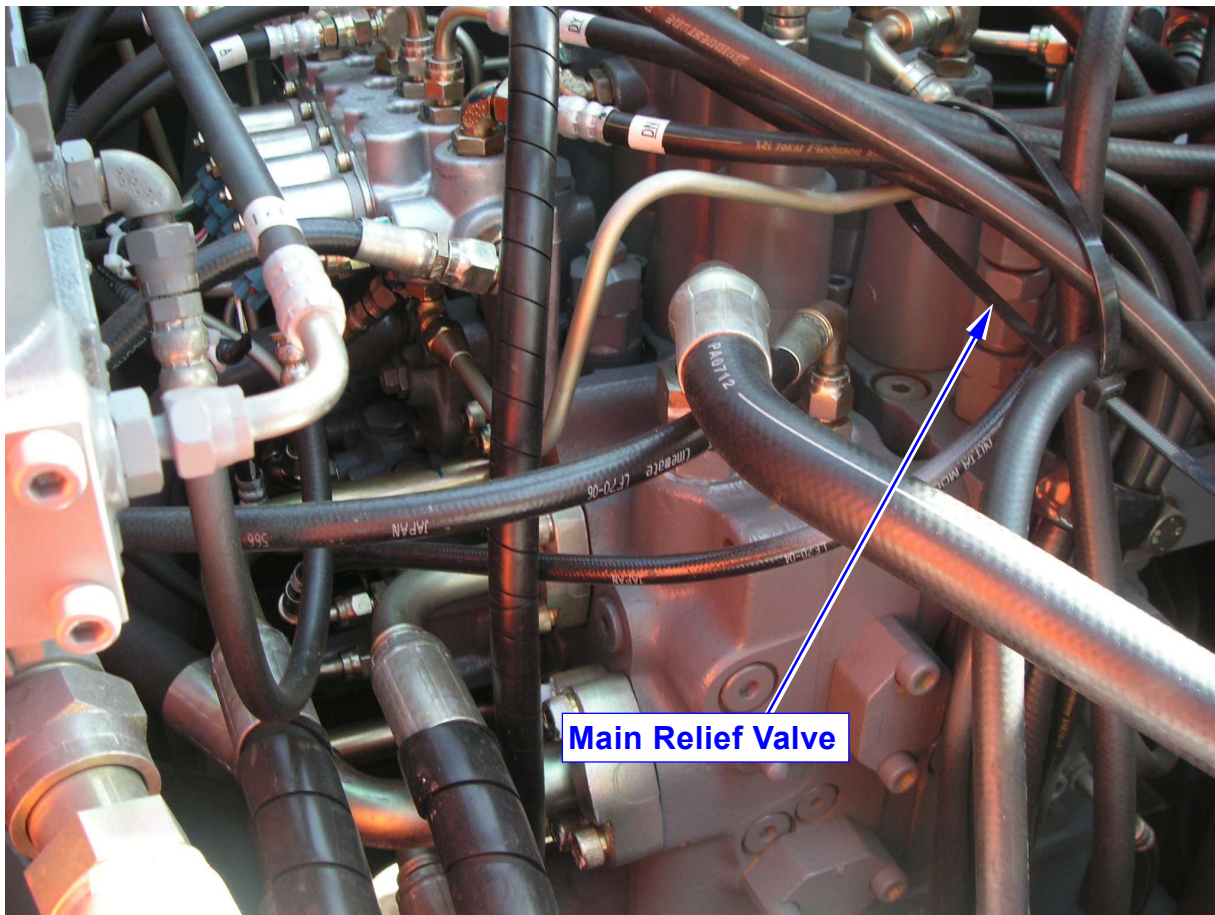

Main Relief Valve

041

Control Valve

- Type Pilot Pressure Operated Type (4-Spools + 5-Spools)

Main Relief Valve

- Set-Pressure Normal : 34.3 MPa (350 kgf/cm²) at 150 L/min
Power Digging : 36.3 MPa (370 kgf/cm²) at 150 L/min

Overload Relief Valve

- Set-Pressure 37.2 MPa (380 kgf/cm²) at 50 L/min
(Boom Lower / Arm Roll-In / Bucket Roll-In)
39.2 MPa (400 kgf/cm²) at 50 L/min
(Boom Raise / Arm Roll-Out / Bucket Roll-Out)

ARM ROLL-IN PRESSURE SENSOR

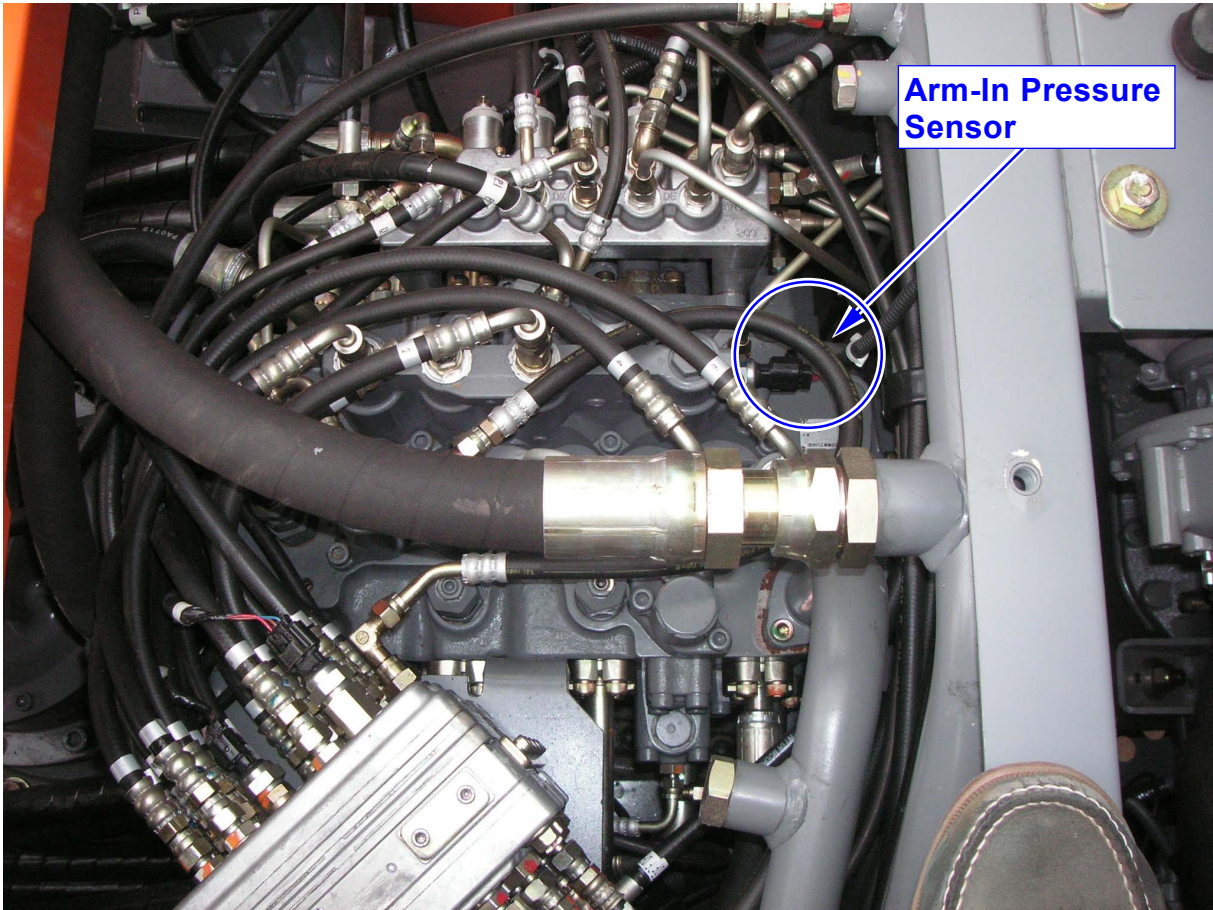

Arm-In Pressure Sensor

042

BOOM-UP PRESSURE SENSOR

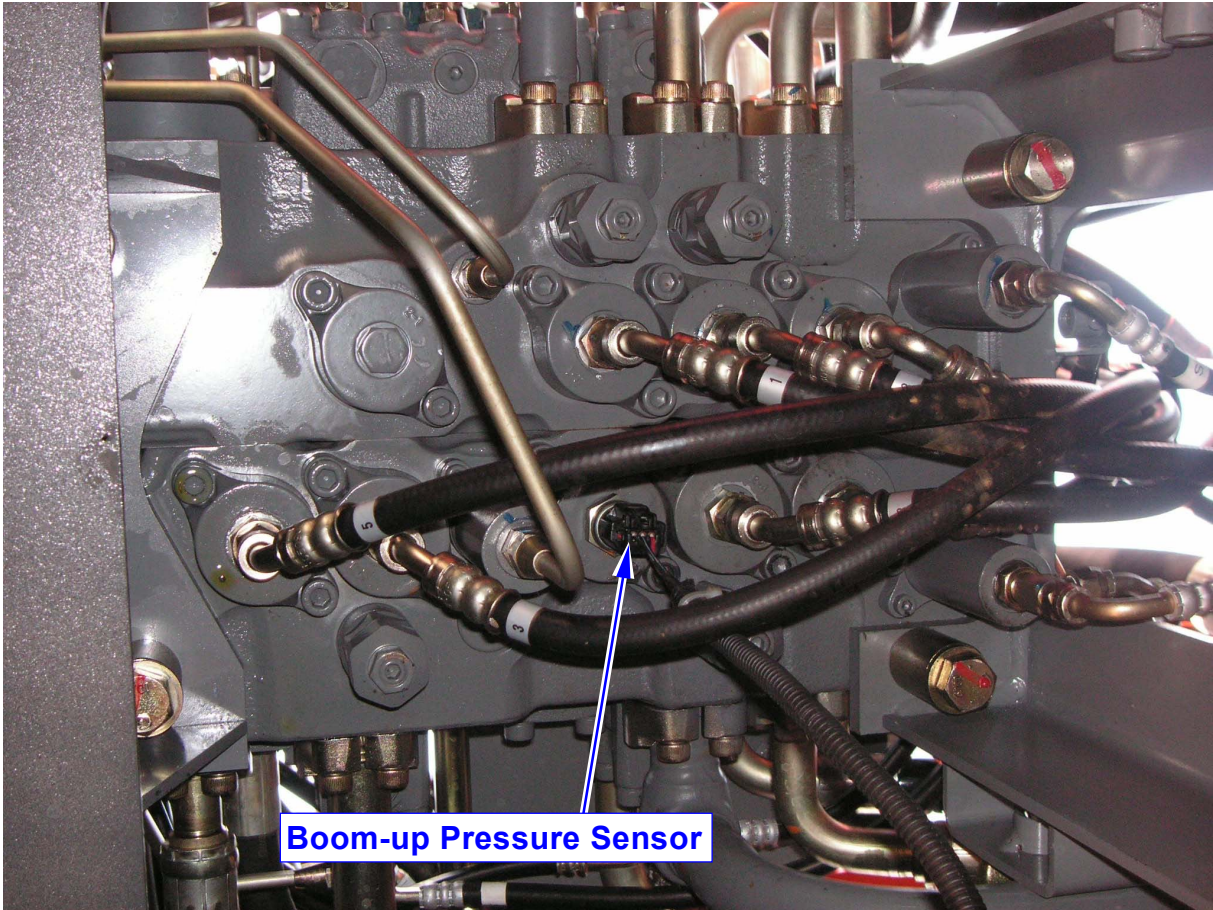

Boom-up Pressure Sensor

043

SIGNAL CONTROL VALVE

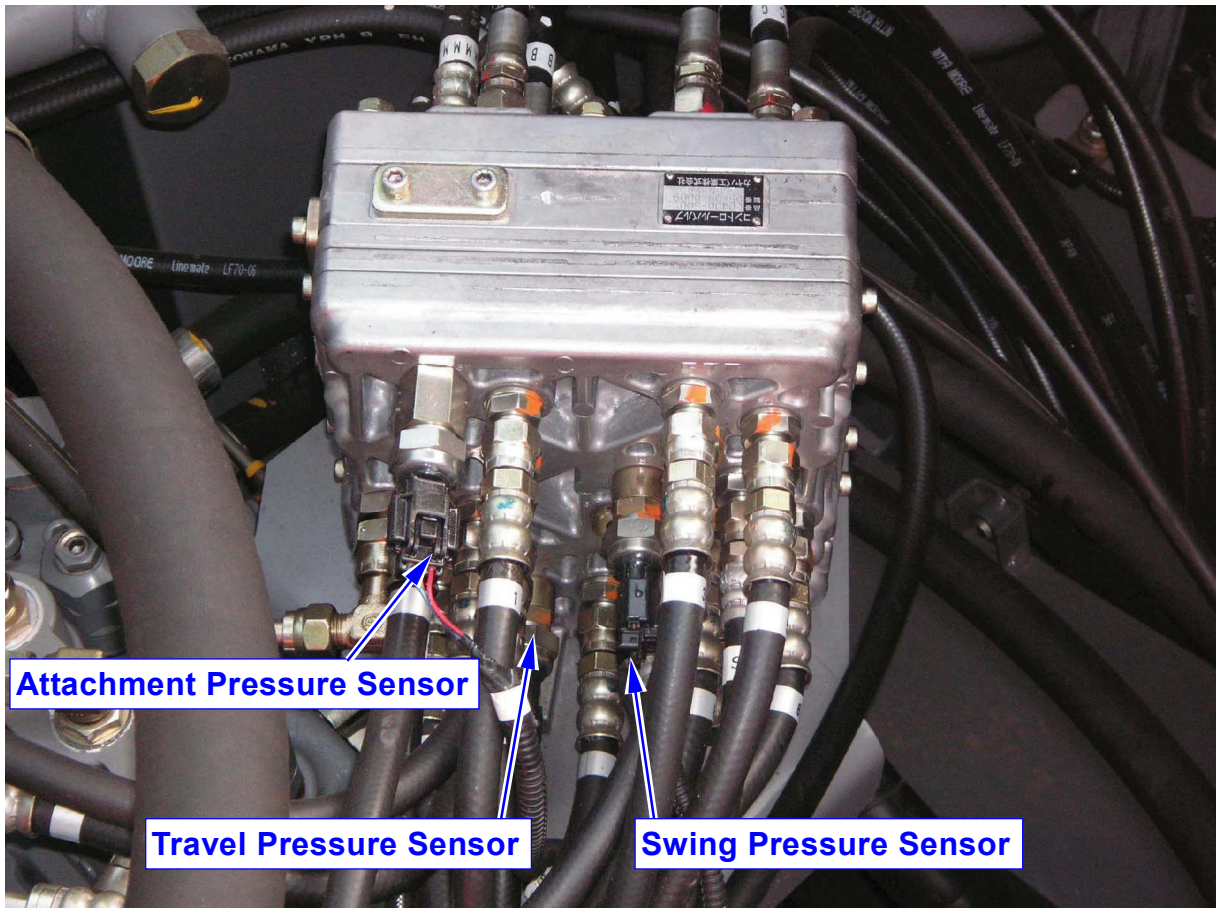

044

SWING DEVICE

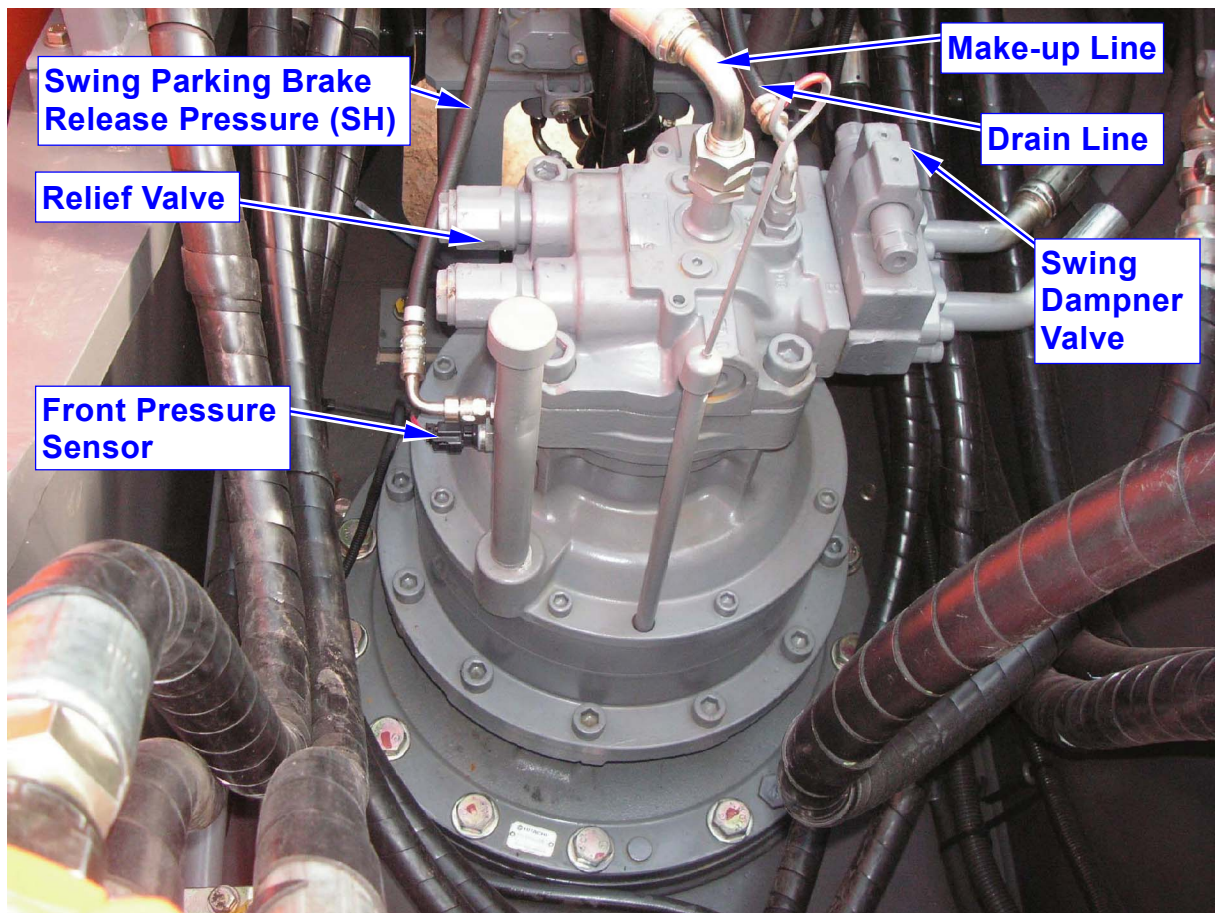

045

Signal Control Valve

- Mode KVSS-10-H
- Rated Pressure 3.7 MPa (38 kgf/cm²)

Swing Device

- Type Two-Stage Reduction Planetary Gear
- Reduction Gear Ratio..... 17.53
- Oil Level Check Interval : Every 250 hours
- Change Oil Interval (Gear Oil) : Every 1000 hours

Swing Motor

- Model M5x130CHB-10A-29B
- Type Swash-Plate Type, Fixed Displacement Axial Plunger Motor.

Swing Parking Brake

- Type Multi-Disc-Wet Negative Type.
- Release Pressure..... 1.9~2.8 MPa (20~28.6 kgf/cm²)

HYDRAULIC OIL TANK



HYDRAULIC OIL TEMPERATURE SENSOR

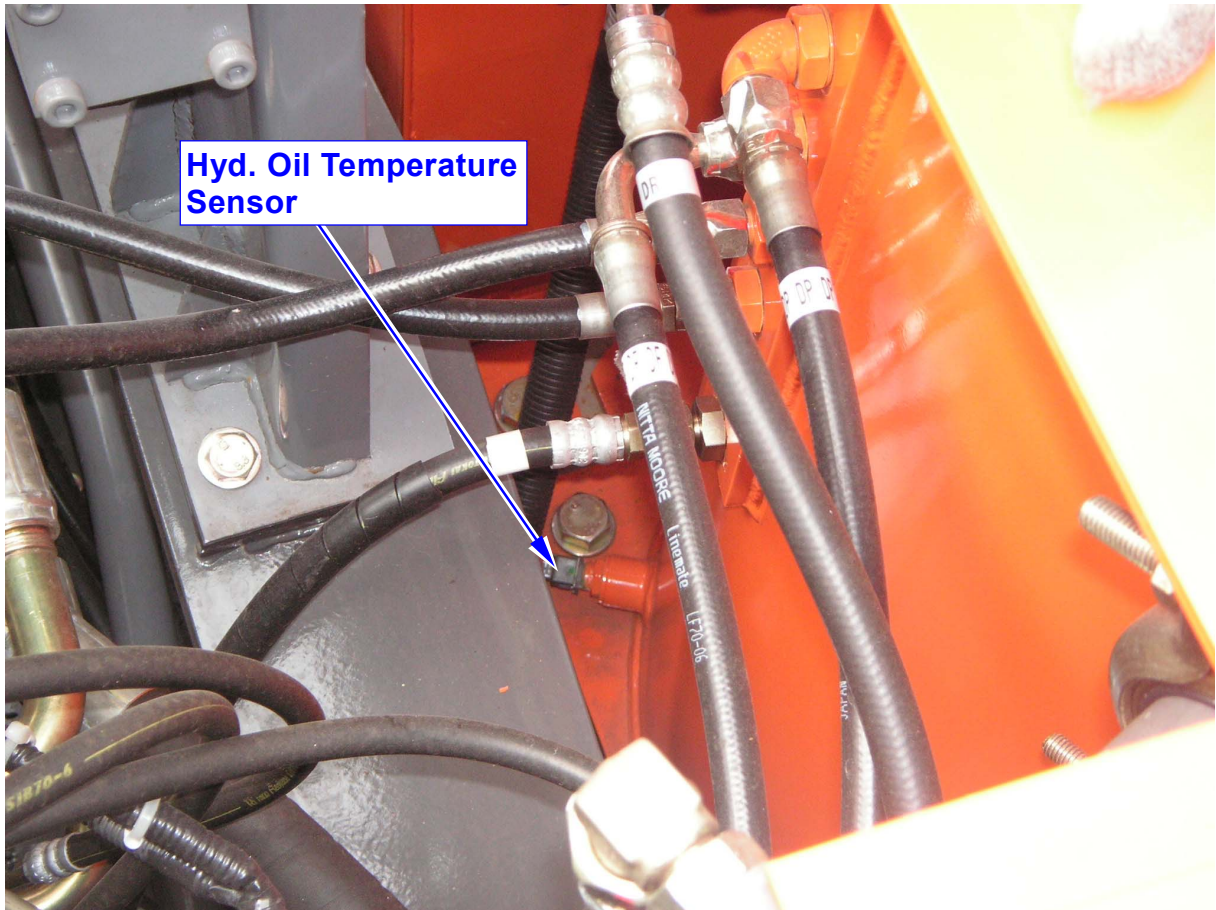

047

048

Hydraulic Oil Tank

- Tank Capacity..... 200 L
- Change Hydraulic. Oil : Every 1000/1500/2500/5000 hours
- Replace Hydraulic Oil Tank Filter : Every 1500 hours
- Replace Air Breather Element : Every 5000 hours
- Cleaning Section Filter : Every 1000/1500/2500/5000 hours

FUEL TANK

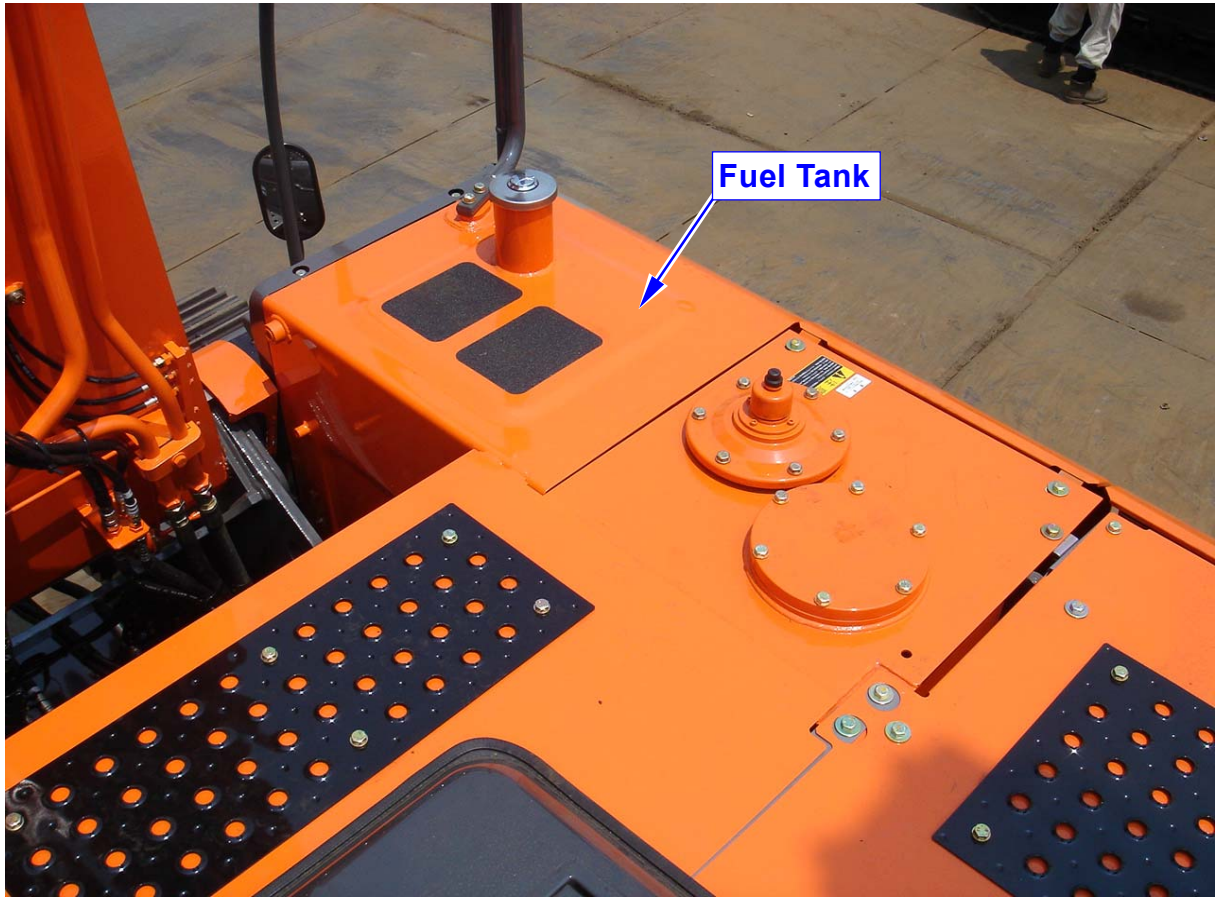

Fuel Tank

049

FUEL LEVEL GAUGE SENSOR

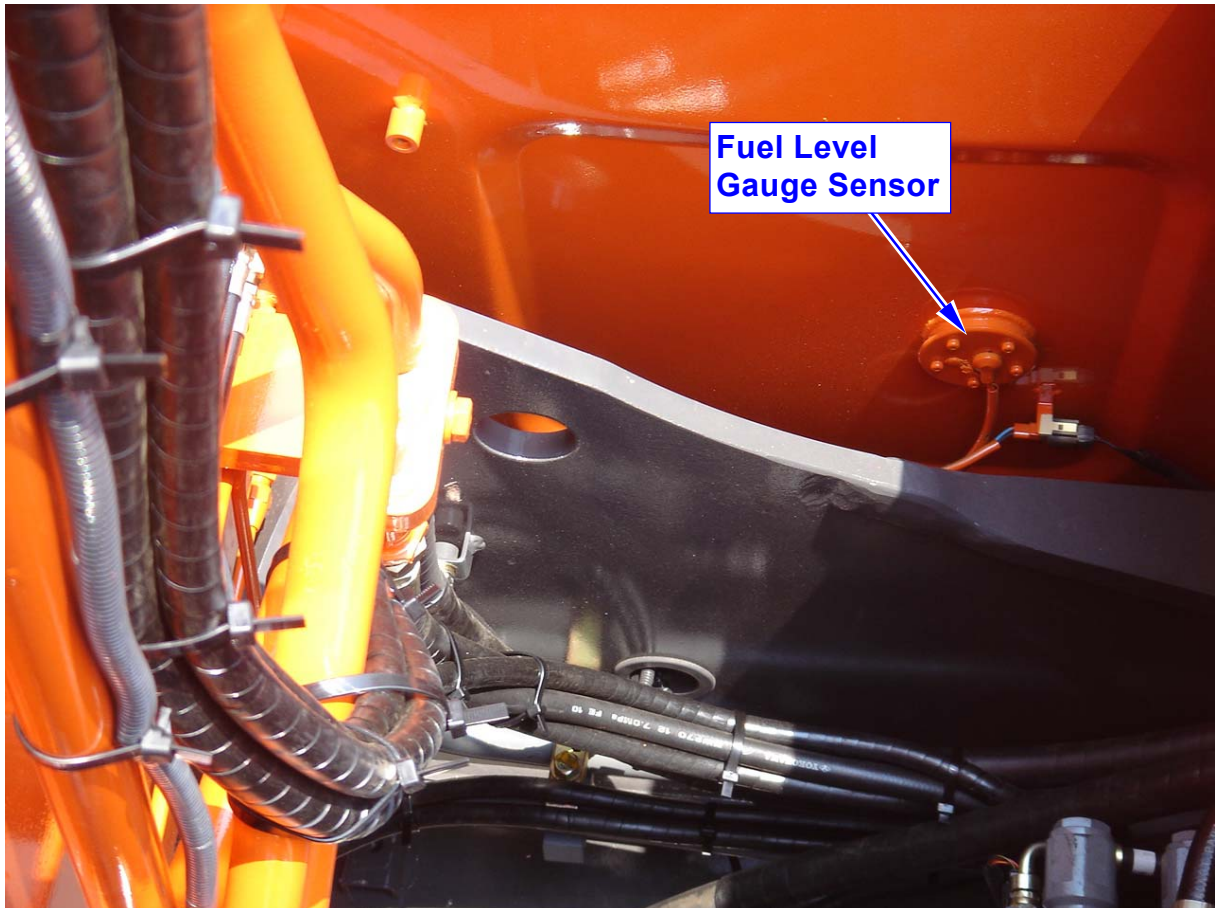

Fuel Level
Gauge Sensor

050

Fuel Tank

- Tank Capacity..... 400 L (ZX200-3)
500 L (ZX270-3)
630 L (ZX330-3)

AUTOMATIC FUEL DEVICE (OPTION)

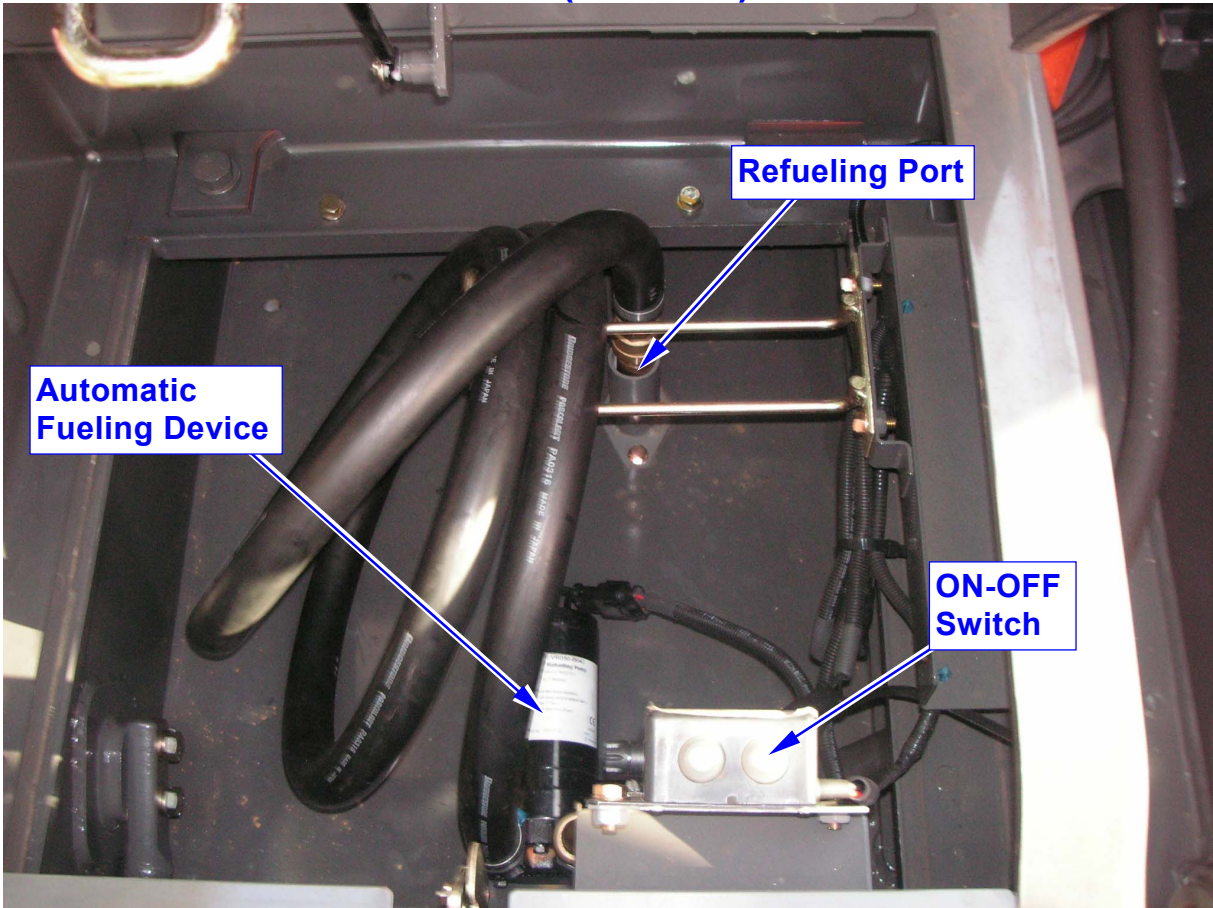

UNDERCARRIAGE



TRACK FRAME

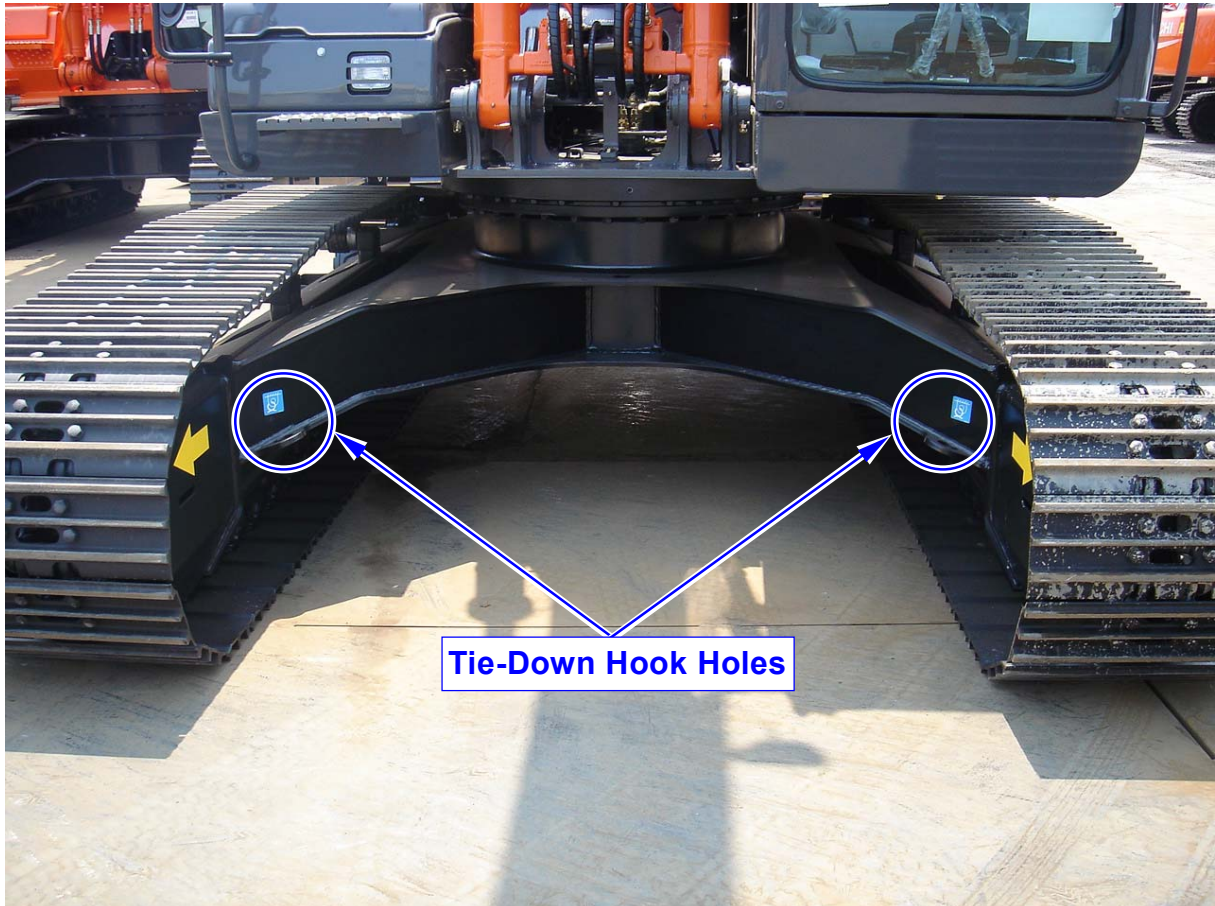

052

053

Track Frame

- Strengthened X-Beam.
This Eliminates Welding to Strengthen the X-Beam.
- Tie-Down Hook Holes.
Provided at the front and Rear of the Lower Flange.

TRACK LINK AND ROLLERS

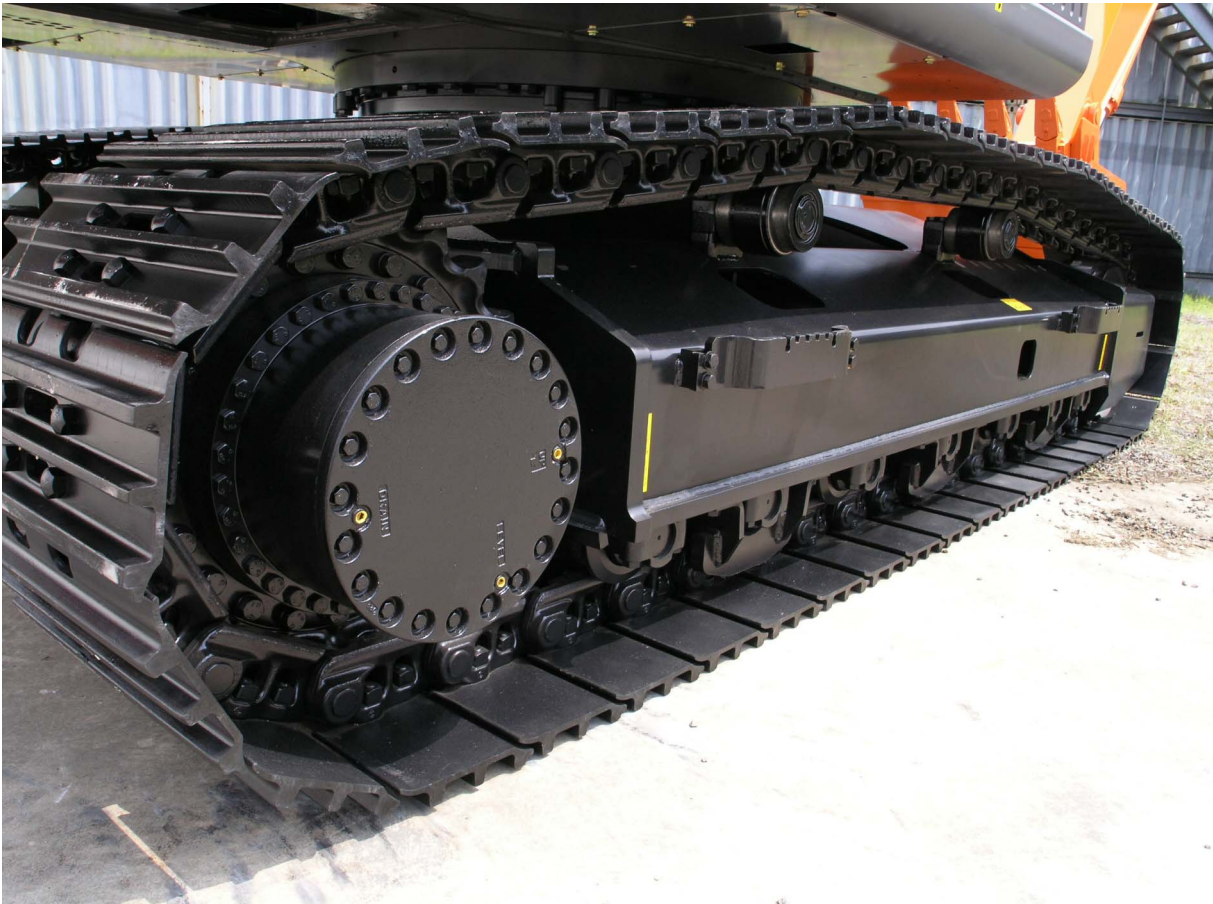

054

FRONT IDLER



055

Rollers

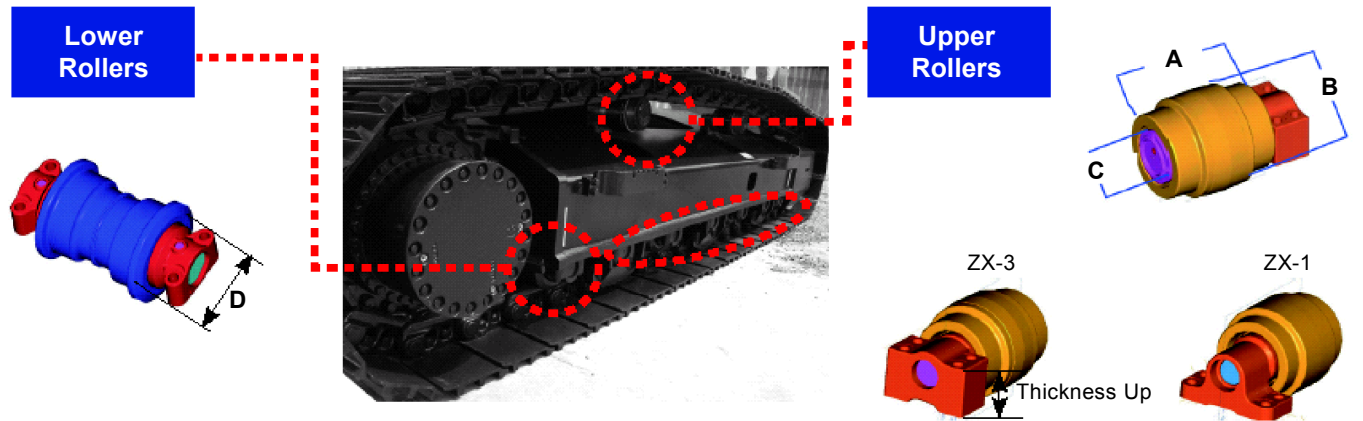

		ZX200-3	ZX200	ZX240-3	ZX230	ZX270-3	ZX270	ZX330-3	ZX330
Upper Rollers	A	165	150	165	150	190	165	190	165
	B	120	120	120	120	150	120	150	120
	C	45	40	45	40	55	45	55	45
Lower Rollers	D	150	150	150	150	180	175	180	175

(mm)

Front Idler

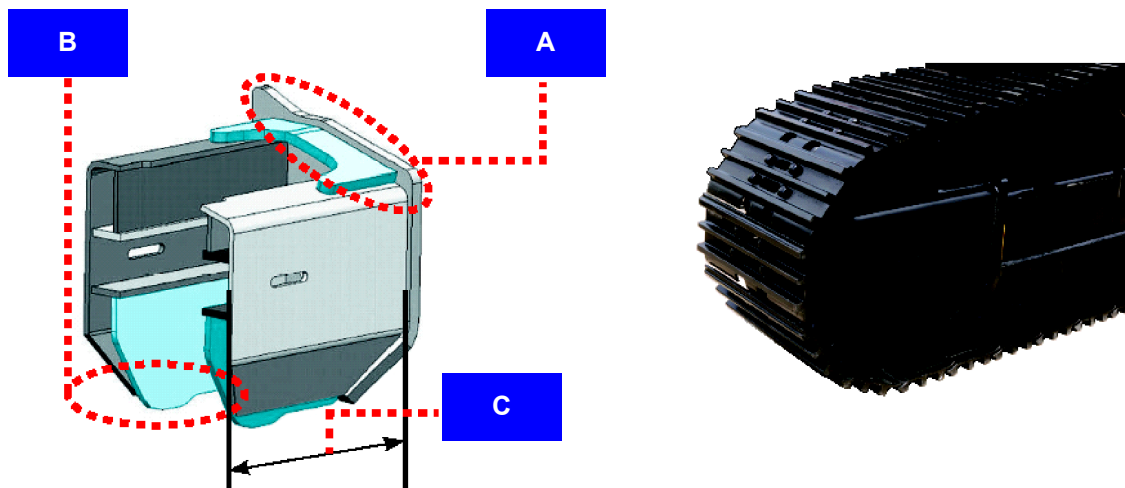

		ZX200-3	ZX200	ZX240-3	ZX230	ZX270-3	ZX270	ZX330-3	ZX330
A	Increase the thickness of the Plate	19	14	19	14	25	14	25	6
B	Increase the thickness of the Plate	14	14	14	14	16	14	16	14
C	Extend width of the Plate	530	485	530	485	595	566	595	566

(mm)

TRAVEL DEVICE



TRAVEL MOTOR

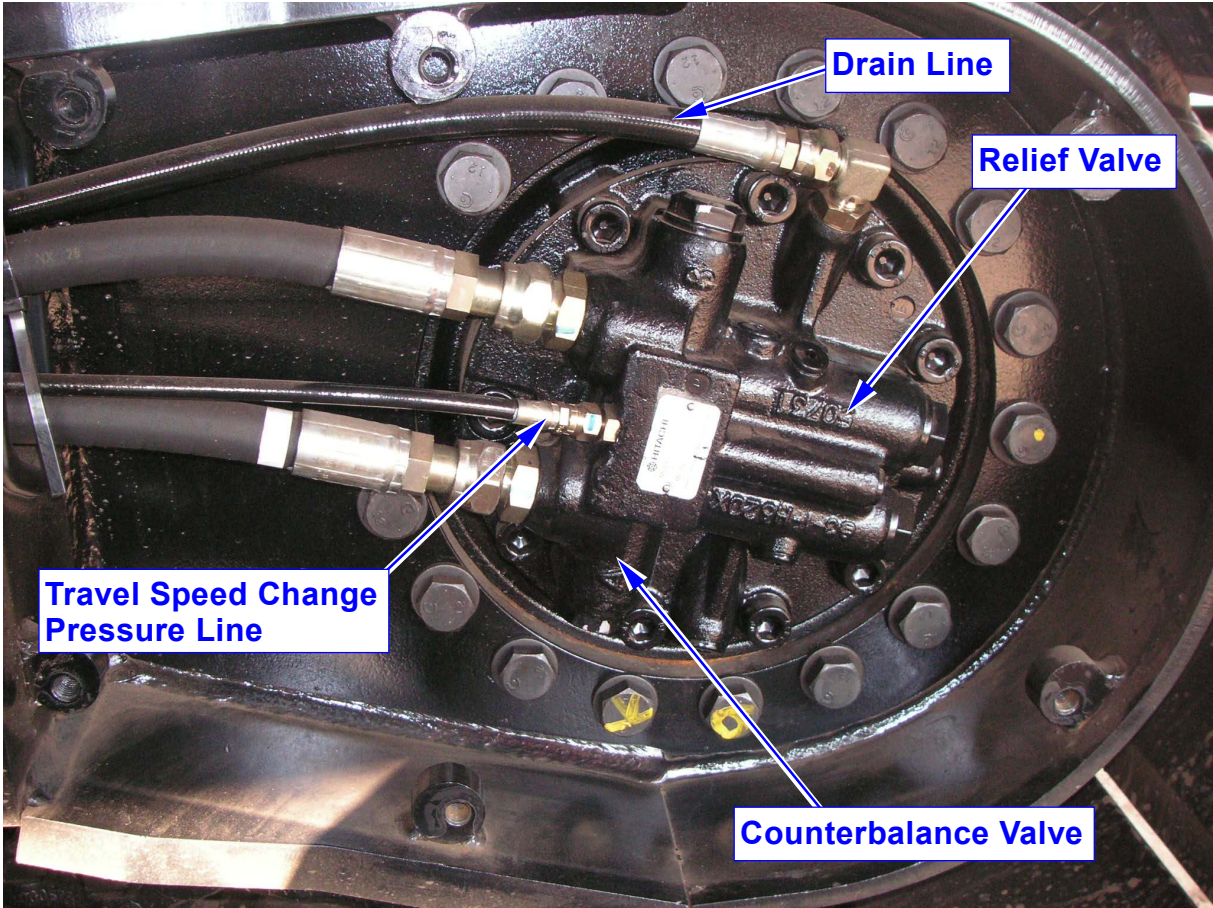

056

057

Travel Device

- Type Three-stage Reduction Planetary Gear.
- Reduction Gear Ratio.....58.702 (ZX200-3)
64.863 (ZX240-3)
70.842 (ZX270-3)
- Oil Capacity6.8 L × 2 (ZX200-3)
7.8 L × 2 (ZX270-3)
9.2 L × 2 (ZX330-3)
- Check Oil Level Interval : Every 250 hours
- Change Gear Oil Interval : Every 2000 hours

Travel Motor

- Type Swash-Plate Type. Variable Displacement Axial Plunger Motor.
- Max. Flow (Theoretical Valve)
(Fast / Slow)79/122 L/min (ZX200-3)
75.7/122.5 L/min (ZX240-3)
86.5/145.5 L/min (ZX270-3)

Travel Brake Valve

- Type Counterbalance Valve Type
- Relief Set Pressure34.8 MPa (355 kgf/cm²)

Travel Parking Brake

- Type Multi-Disc-Wet Negative Type
- Release Stating Pressure0.97 MPa (9.9 kgf/cm²) (ZX200-3~ZX240-3)
1.07 to 1.23 MPa (10.9 to 12.5 kgf/cm²) (ZX270-3)

CENTER JOINT (1)

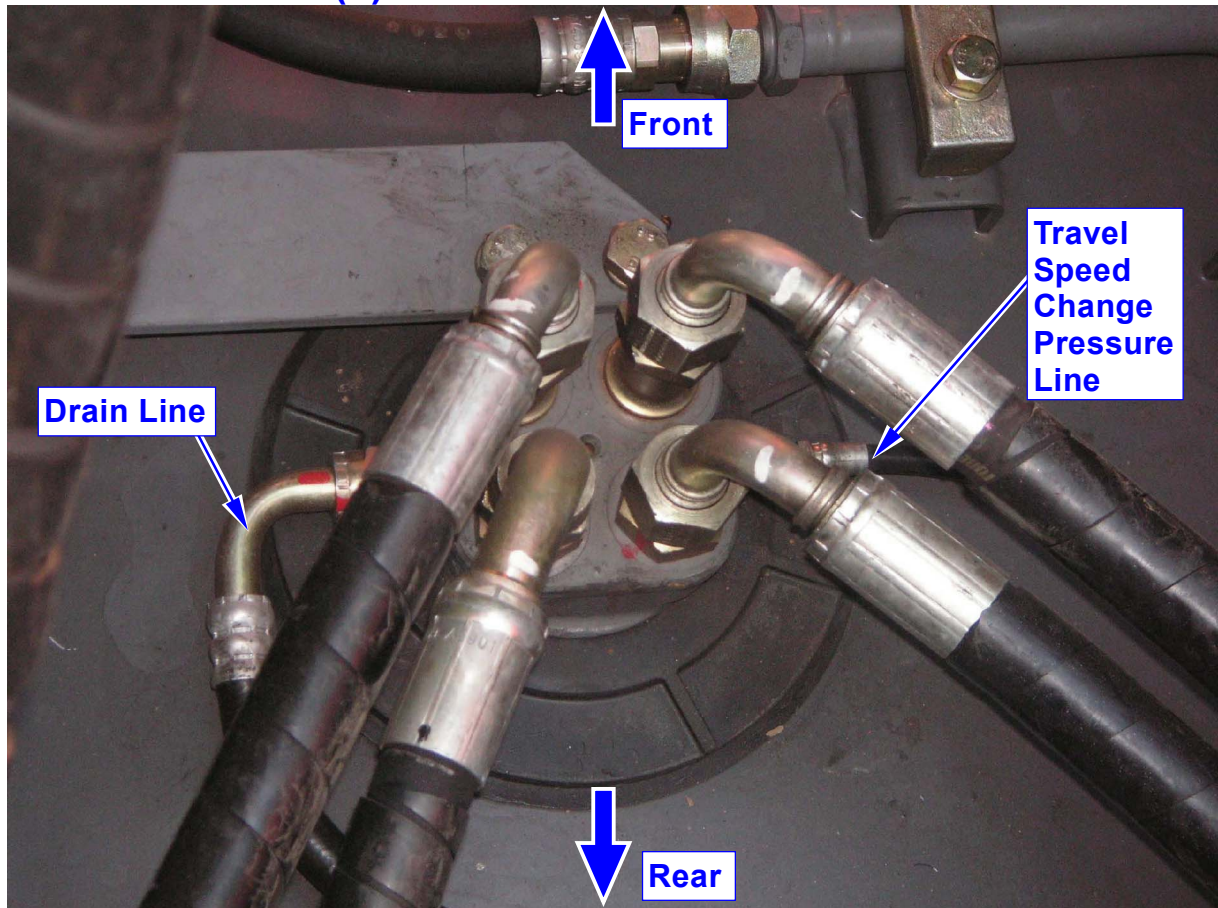

058

CENTER JOINT (2)

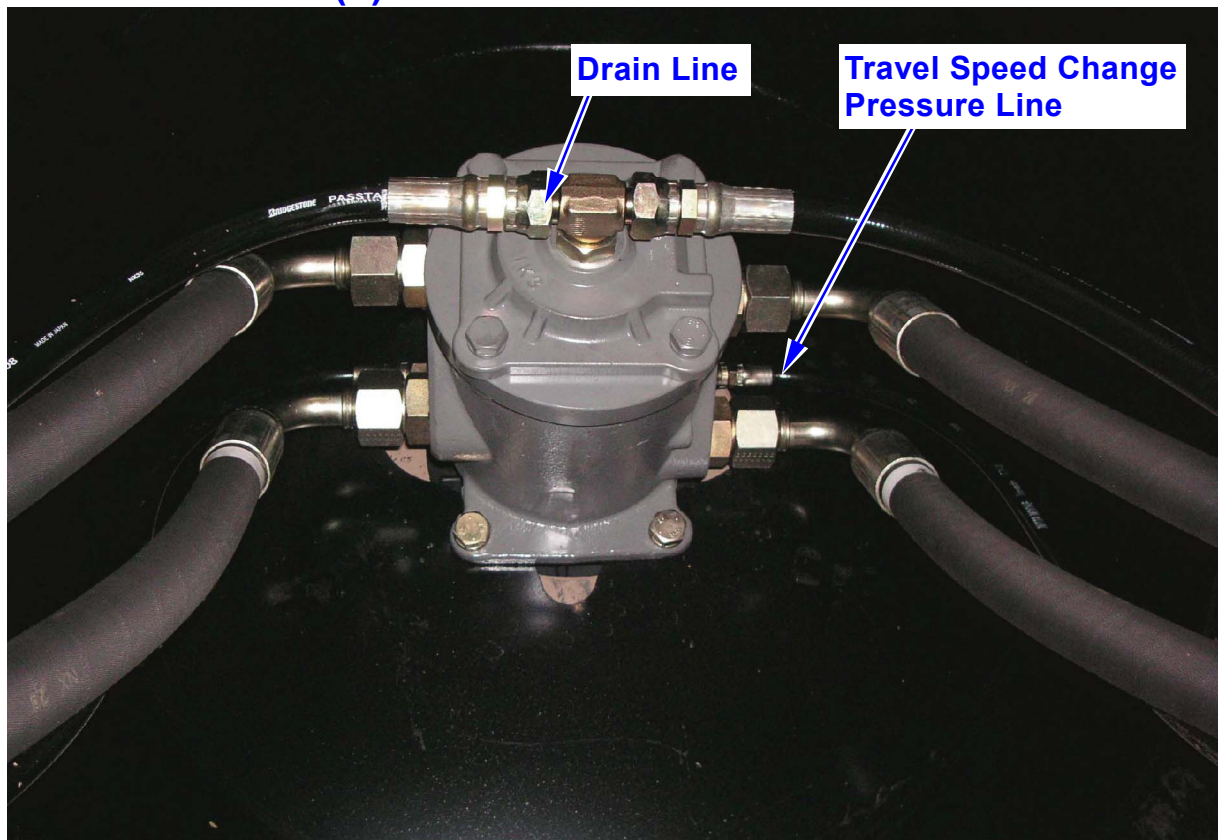

059

FRONT ATTACHMENT (STANDARD)



ATTACHMENT PIPING (STANDARD)

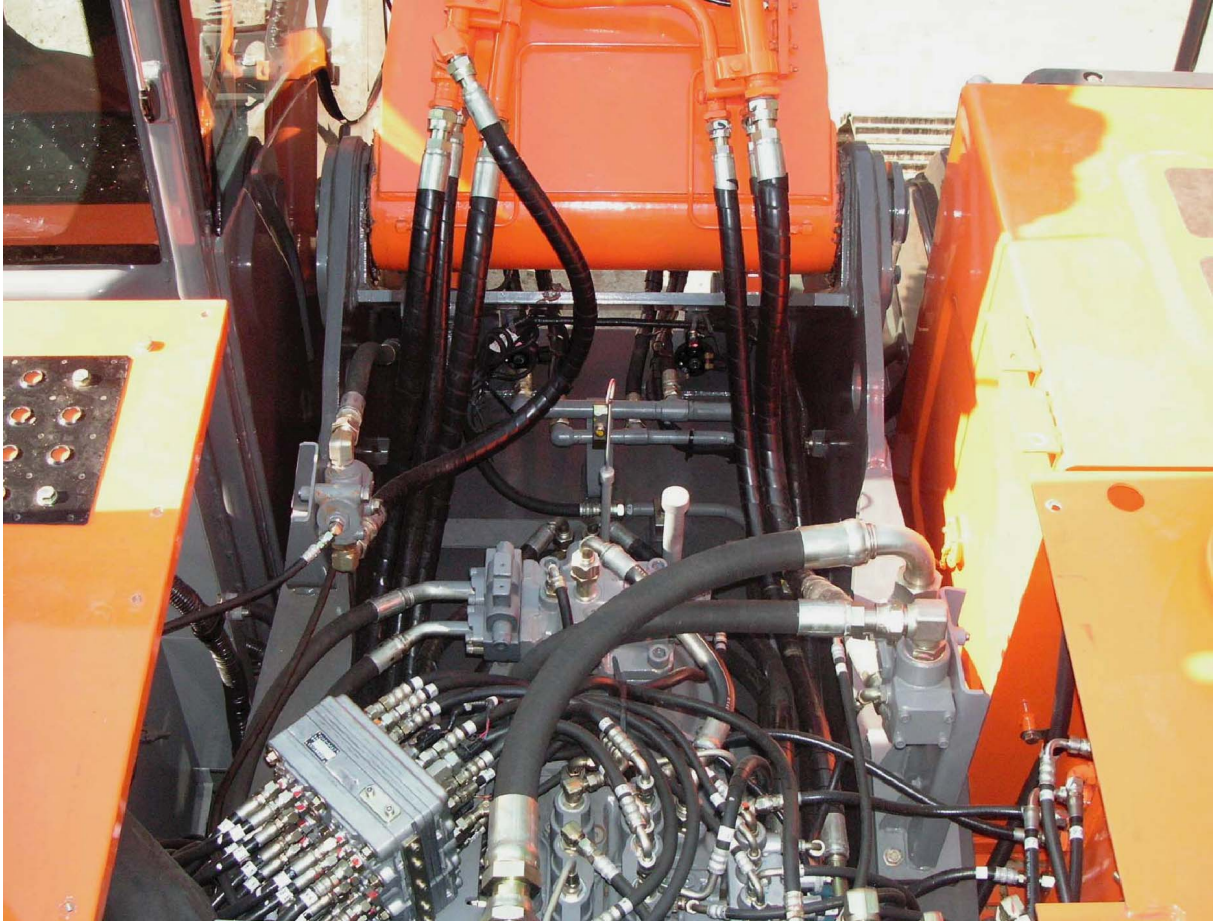

060

061

(1) Measurement of Boom

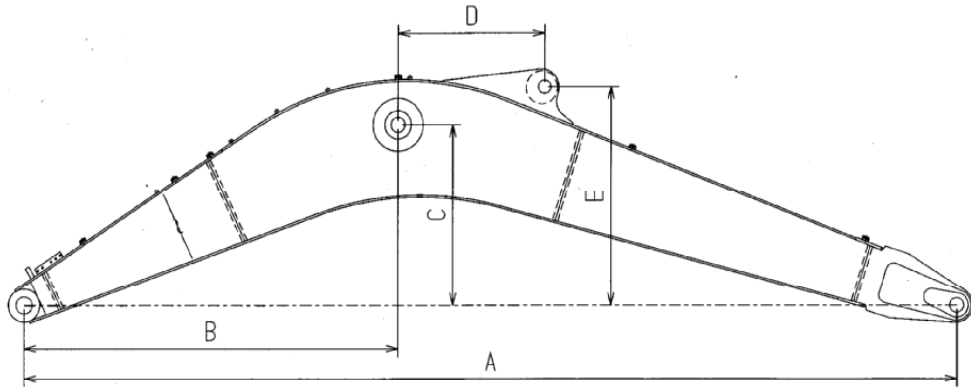

(mm)

Model Region	ZX200-3	ZX200	ZX230-3	ZX230	ZX270-3	ZX270	ZX330-3	ZX330
A	5680	5680	6000	6000	6200	6200	6400	6400
B	2312	2155	2463	2405	2370	2338	2780	2788
C	959	1000	1084	1095	1139	1148	1105	1095
D	934	1060	938	940	1107	1286	684	590
E	1161.5	1170	1306	1325	1386	1320	1441.7	1450

(2) Plate Thickness Up for Boom

(mm)

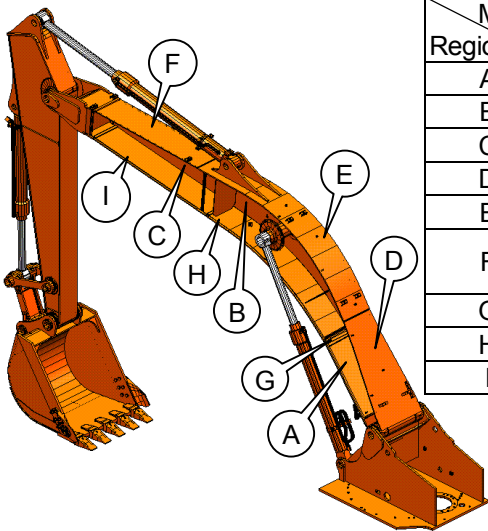

Model Region	ZX200-3	ZX200	ZX230-3	ZX230	ZX270-3	ZX270	ZX330-3	ZX330
A	19	16	19	19	19	19	22	19
B	14	14	19	19	16	16	16	16
C	10	9	10	10	12	12	12	12
D	12	12	12	12	16	16	19	19
E	16	14	16	16	16	16	19	19
F	10	10	12	12	14	14	12 (HT50)	12 (HT50)
G	12	12	12	12	14	14	14	14
H	12	12	14	14	14	14	19	19
I	10	10	14	14	14	14	19	19

(3) Boom Foot Bracket

(mm)

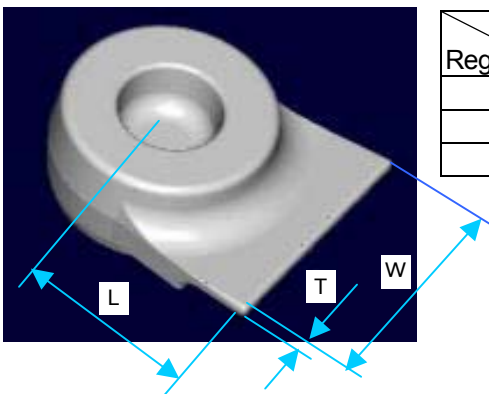

Model Region	ZX200-3	ZX200	ZX230-3	ZX230	ZX270-3	ZX270	ZX330-3	ZX330
T	19	16	19	19	19	19	22	19
W	229	218	250.6	241.5	250.6	241.5	269.8	268.4
L	200	155	200	160	200	160	200	200

HOSE RUPTURE VALVE FOR MONO BOOM TYPE (OPTION)

