



Operation and Maintenance Manual

C27 and C32 Generator Sets

DWB1-Up (Generator Set)
SXC1-Up (Generator Set)
WDR1-Up (Generator Set)

Important Safety Information

Most accidents that involve product operation, maintenance and repair are caused by failure to observe basic safety rules or precautions. An accident can often be avoided by recognizing potentially hazardous situations before an accident occurs. A person must be alert to potential hazards. This person should also have the necessary training, skills and tools to perform these functions properly.

Improper operation, lubrication, maintenance or repair of this product can be dangerous and could result in injury or death.

Do not operate or perform any lubrication, maintenance or repair on this product, until you have read and understood the operation, lubrication, maintenance and repair information.

Safety precautions and warnings are provided in this manual and on the product. If these hazard warnings are not heeded, bodily injury or death could occur to you or to other persons.

The hazards are identified by the "Safety Alert Symbol" and followed by a "Signal Word" such as "DANGER", "WARNING" or "CAUTION". The Safety Alert "WARNING" label is shown below.



The meaning of this safety alert symbol is as follows:

Attention! Become Alert! Your Safety is Involved.

The message that appears under the warning explains the hazard and can be either written or pictorially presented.

Operations that may cause product damage are identified by "NOTICE" labels on the product and in this publication.

Caterpillar cannot anticipate every possible circumstance that might involve a potential hazard. The warnings in this publication and on the product are, therefore, not all inclusive. If a tool, procedure, work method or operating technique that is not specifically recommended by Caterpillar is used, you must satisfy yourself that it is safe for you and for others. You should also ensure that the product will not be damaged or be made unsafe by the operation, lubrication, maintenance or repair procedures that you choose.

The information, specifications, and illustrations in this publication are on the basis of information that was available at the time that the publication was written. The specifications, torques, pressures, measurements, adjustments, illustrations, and other items can change at any time. These changes can affect the service that is given to the product. Obtain the complete and most current information before you start any job. Caterpillar dealers have the most current information available.



When replacement parts are required for this product Caterpillar recommends using Caterpillar replacement parts or parts with equivalent specifications including, but not limited to, physical dimensions, type, strength and material.

Failure to heed this warning can lead to premature failures, product damage, personal injury or death.

Table of Contents

Foreword	4
----------------	---

Safety Section

Safety Messages	6
General Hazard Information	12
Burn Prevention	14
Fire Prevention and Explosion Prevention	15
Crushing Prevention and Cutting Prevention	17
Mounting and Dismounting	17
Before Starting Engine	17
Engine Starting	17
Engine Stopping	18
Electrical System	18
Generator Isolating for Maintenance	19

Product Information Section

Model Views and Specifications	20
Product Identification Information	25

Operation Section

Lifting and Storage	34
Installation	36
Features and Controls	38
Engine Starting	52
Engine Operation	55
Engine Stopping	56
Cold Weather Operation	57
Generator Operation	59
Voltage Regulators	64

Maintenance Section

Refill Capacities	66
Maintenance Recommendations	68

Maintenance Interval Schedule (Standby)	73
Maintenance Interval Schedule (Standard)	75

Reference Information Section

Engine Ratings	126
Customer Service	128
Reference Materials	130

Index Section

Index	139
-------------	-----

Foreword

Literature Information

This manual contains safety, operation instructions, lubrication and maintenance information. This manual should be stored in or near the engine area in a literature holder or literature storage area. Read, study and keep it with the literature and engine information.

English is the primary language for all Caterpillar publications. The English used facilitates translation and consistency in electronic media delivery.

Some photographs or illustrations in this manual show details or attachments that may be different from your engine. Guards and covers may have been removed for illustrative purposes. Continuing improvement and advancement of product design may have caused changes to your engine which are not included in this manual. Whenever a question arises regarding your engine, or this manual, please consult with your Caterpillar dealer for the latest available information.

Safety

This safety section lists basic safety precautions. In addition, this section identifies hazardous, warning situations. Read and understand the basic precautions listed in the safety section before operating or performing lubrication, maintenance and repair on this product.

Operation

Operating techniques outlined in this manual are basic. They assist with developing the skills and techniques required to operate the engine more efficiently and economically. Skill and techniques develop as the operator gains knowledge of the engine and its capabilities.

The operation section is a reference for operators. Photographs and illustrations guide the operator through procedures of inspecting, starting, operating and stopping the engine. This section also includes a discussion of electronic diagnostic information.

Maintenance

The maintenance section is a guide to engine care. The illustrated, step-by-step instructions are grouped by fuel consumption, service hours and/or calendar time maintenance intervals. Items in the maintenance schedule are referenced to detailed instructions that follow.

Use fuel consumption or service hours to determine intervals. Calendar intervals shown (daily, annually, etc.) may be used instead of service meter intervals if they provide more convenient schedules and approximate the indicated service meter reading.

Recommended service should be performed at the appropriate intervals as indicated in the Maintenance Interval Schedule. The actual operating environment of the engine also governs the Maintenance Interval Schedule. Therefore, under extremely severe, dusty, wet or freezing cold operating conditions, more frequent lubrication and maintenance than is specified in the Maintenance Interval Schedule may be necessary.

The maintenance schedule items are organized for a preventive maintenance management program. If the preventive maintenance program is followed, a periodic tune-up is not required. The implementation of a preventive maintenance management program should minimize operating costs through cost avoidances resulting from reductions in unscheduled downtime and failures.

Maintenance Intervals

Perform maintenance on items at multiples of the original requirement. Each level and/or individual items in each level should be shifted ahead or back depending upon your specific maintenance practices, operation and application. We recommend that the maintenance schedules be reproduced and displayed near the engine as a convenient reminder. We also recommend that a maintenance record be maintained as part of the engine's permanent record.

See the section in the Operation and Maintenance Manual, "Maintenance Records" for information regarding documents that are generally accepted as proof of maintenance or repair. Your authorized Caterpillar dealer can assist you in adjusting your maintenance schedule to meet the needs of your operating environment.

Overhaul

Major engine overhaul details are not covered in the Operation and Maintenance Manual except for the interval and the maintenance items in that interval. Major repairs are best left to trained personnel or an authorized Caterpillar dealer. Your Caterpillar dealer offers a variety of options regarding overhaul programs. If you experience a major engine failure, there are also numerous after failure overhaul options available from your Caterpillar dealer. Consult with your dealer for information regarding these options.

California Proposition 65 Warning

Diesel engine exhaust and some of its constituents are known to the State of California to cause cancer, birth defects, and other reproductive harm.

Battery posts, terminals and related accessories contain lead and lead compounds. **Wash hands after handling.**

Safety Section

i02879636

Safety Messages

SMCS Code: 1000; 7405

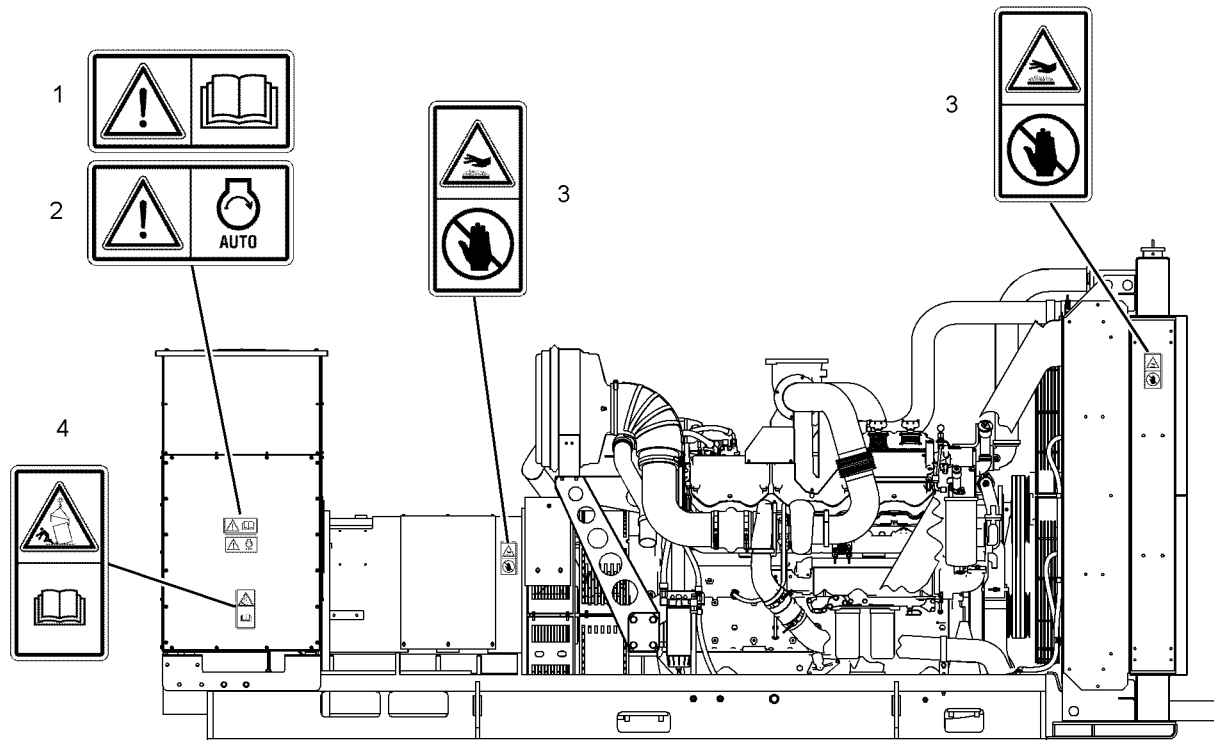

Illustration 1
C27 Generator Set right side view

g01433816

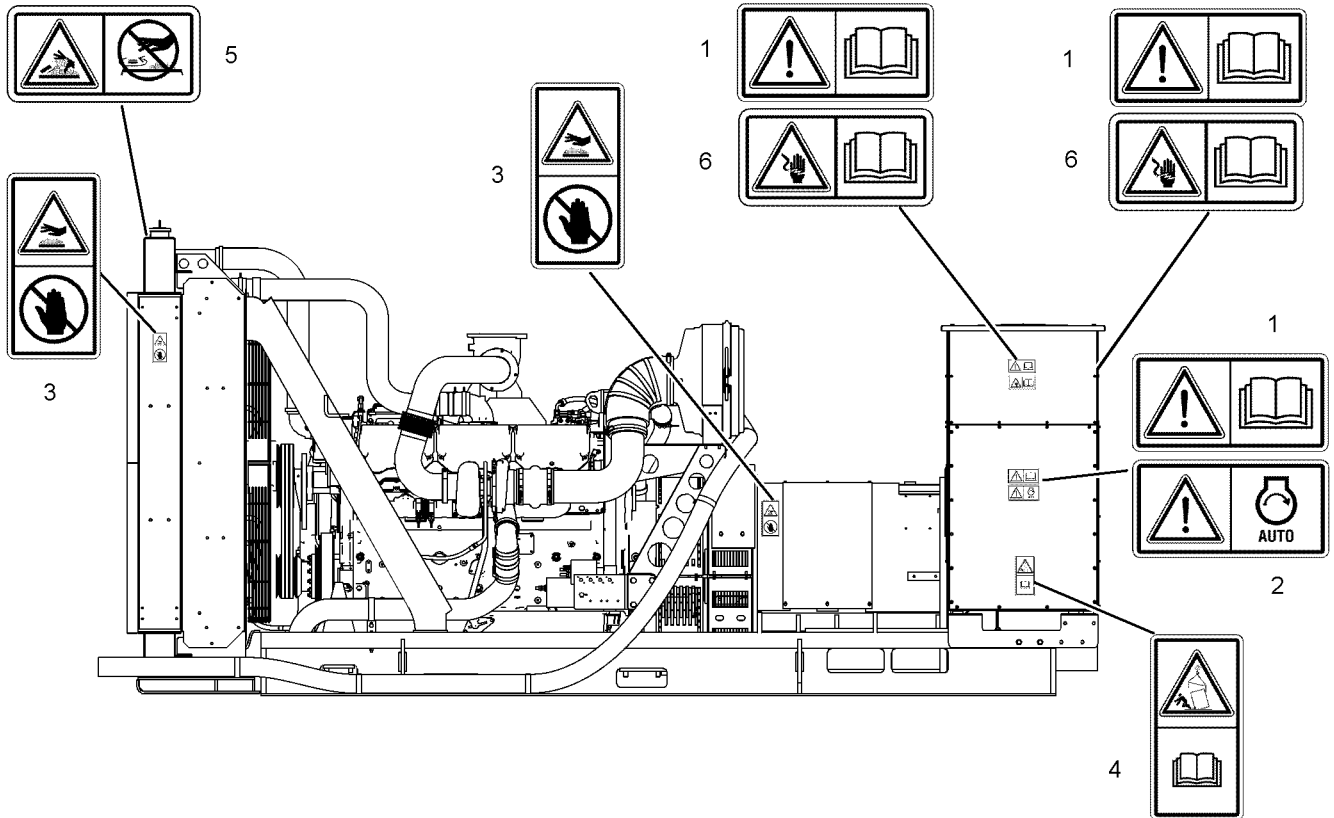

Illustration 2
C27 Generator Set left side view

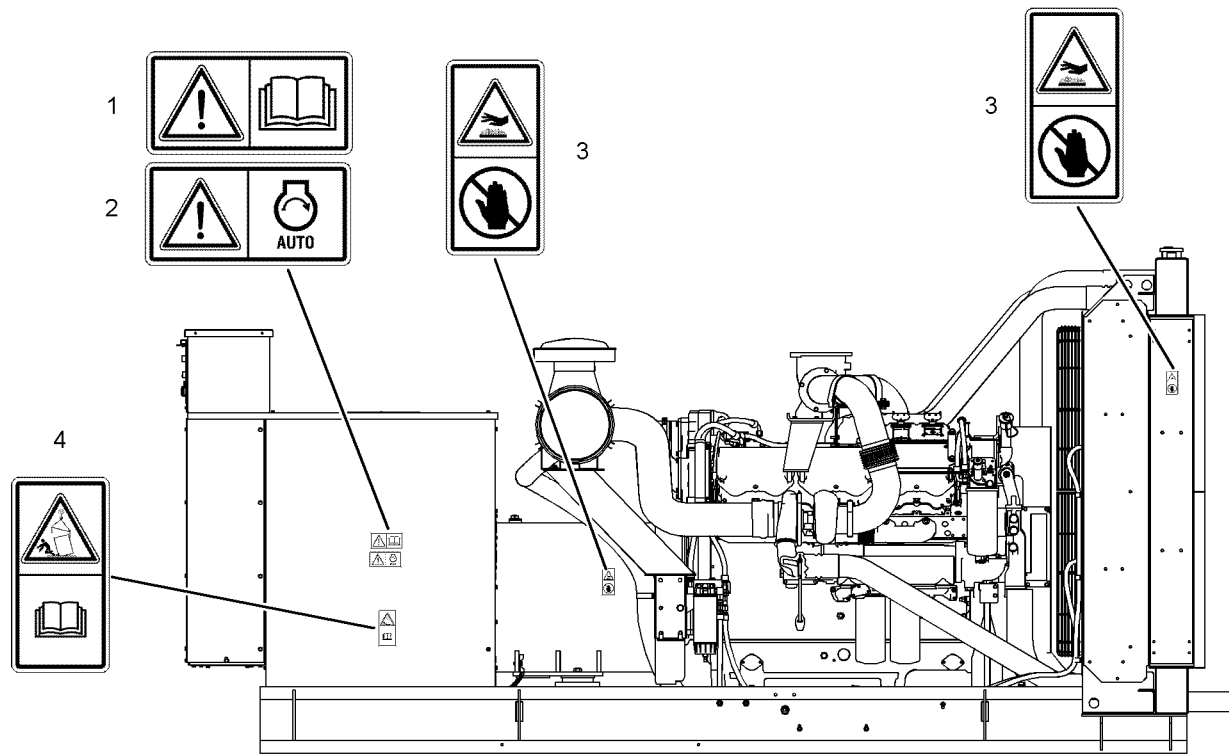

Illustration 3
C32 Generator Set right side view

g01433818

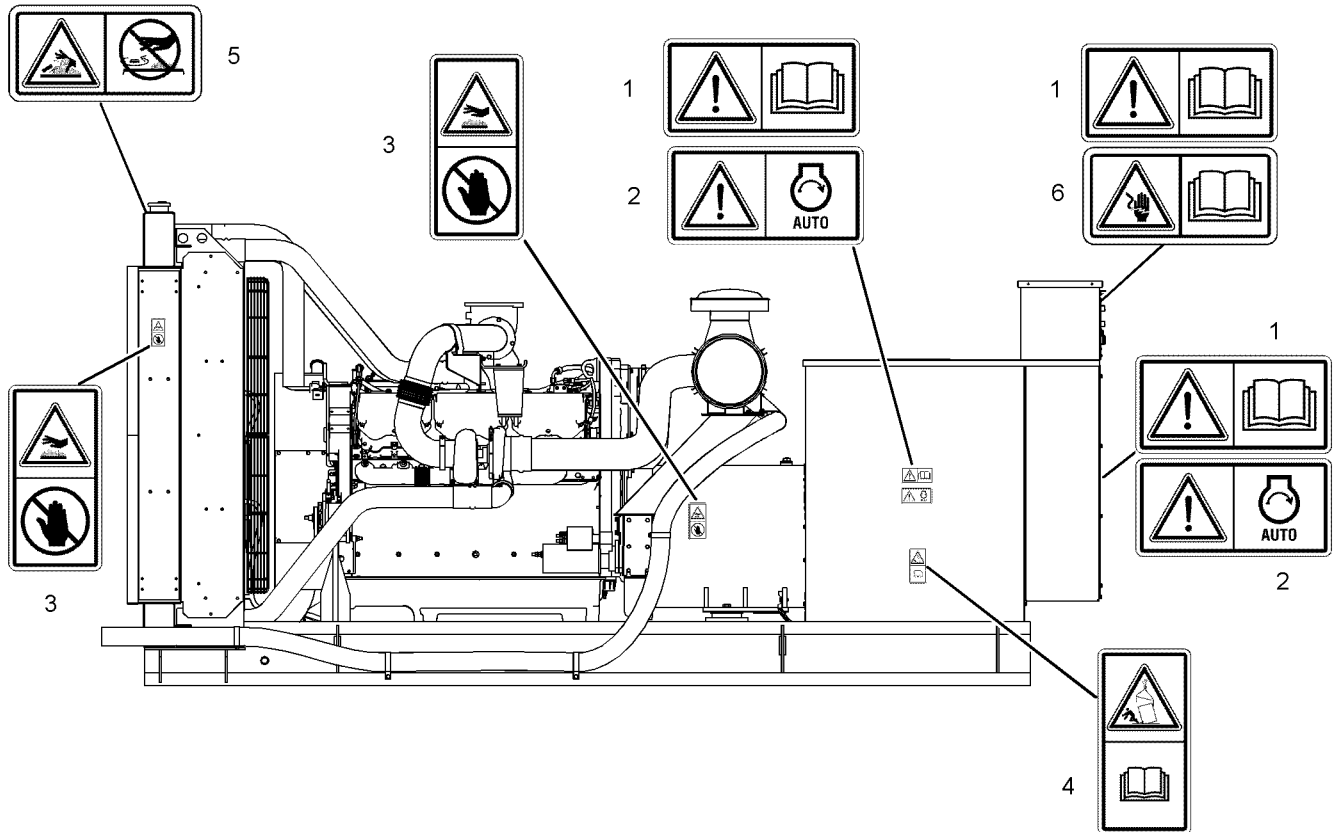

Illustration 4
C32 Generator Set left side view

g01433805

Universal Warning (1)

The universal safety message is located on each side of the generator enclosure and on each side of the terminal box.



g01370904

WARNING

Do not operate or work on this product unless you have read and understand the instructions and warnings in the Operation and Maintenance Manual. Failure to follow the instructions or heed the warnings could result in injury or death. Contact any Caterpillar dealer for replacement manuals. Proper care is your responsibility.

Automatic Starting (2)

The safety message for automatic starting is located on each side of the enclosure.



g01392484

WARNING

When the engine is in the AUTOMATIC mode, the engine can start at any moment. To avoid personal injury, always remain clear of the the engine when the engine is in the AUTOMATIC mode.

Hot Surface (3)

These safety messages are located on each side of the radiator and on each side of the barrel of the generator.



g01384734

WARNING

Hot parts or hot components can cause burns or personal injury. Do not allow hot parts or components to contact your skin. Use protective clothing or protective equipment to protect your skin.

Lifting the Genset (4)

This safety message for lifting the genset is located on right, left, and rear panels of the generator enclosure.

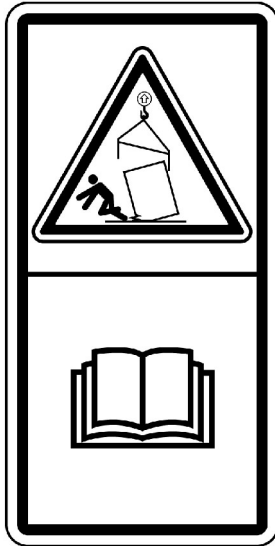

g01433231

WARNING

Crushing Hazard! Improper lifting could cause serious injury or death. Follow the lifting instructions in the Operation and Maintenance Manual for safe lifting procedures.

Hot Fluid Under Pressure (5)

The safety message for hot fluid under pressure is located on top of the radiator near the radiator cap.



g01371640

WARNING

Pressurized system! Hot coolant can cause serious burns, injury or death. To open the cooling system filler cap, stop the engine and wait until the cooling system components are cool. Loosen the cooling system pressure cap slowly in order to relieve the pressure. Read and understand the Operation and Maintenance Manual before performing any cooling system maintenance.

Electrical Shock (6)

The safety message for electrical shock is located on the sides of the terminal box.

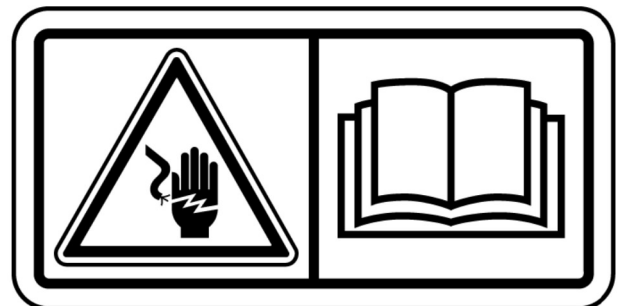

g01372247

WARNING

WARNING! Shock/Electrocution Hazard! Read and understand the instructions and warnings in the Operation and Maintenance Manual. Failure to follow the instructions or heed the warnings could cause serious injury or death.

i02574315

General Hazard Information

SMCS Code: 1000; 4450; 7405

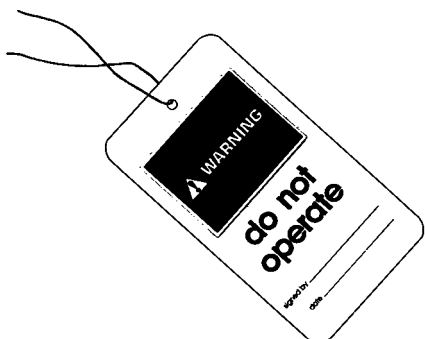

Illustration 5

g00104545

Attach a “Do Not Operate” warning tag or a similar warning tag to the start switch or to the controls before the engine is serviced or before the engine is repaired. These warning tags (Special Instruction, SEHS7332) are available from your Caterpillar dealer. Attach the warning tags to the engine and to each operator control station. When it is appropriate, disconnect the starting controls.

Do not allow unauthorized personnel on the engine, or around the engine when the engine is being serviced.

Engine exhaust contains products of combustion which may be harmful to your health. Always start the engine and operate the engine in a well ventilated area. If the engine is in an enclosed area, vent the engine exhaust to the outside.

Cautiously remove the following parts. To help prevent spraying or splashing of pressurized fluids, hold a rag over the part that is being removed.

- Filler caps
- Grease fittings
- Pressure taps
- Breathers
- Drain plugs

Use caution when cover plates are removed. Gradually loosen, but do not remove the last two bolts or nuts that are located at opposite ends of the cover plate or the device. Before removing the last two bolts or nuts, pry the cover loose in order to relieve any spring pressure or other pressure.

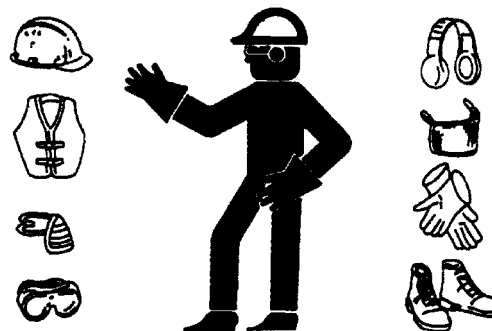

Illustration 6

g00702020

- Wear a hard hat, protective glasses, and other protective equipment, as required.
- When work is performed around an engine that is operating, wear protective devices for ears in order to help prevent damage to hearing.
- Do not wear loose clothing or jewelry that can snag on controls or on other parts of the engine.
- Ensure that all protective guards and all covers are secured in place on the engine.
- Never put maintenance fluids into glass containers. Glass containers can break.
- Use all cleaning solutions with care.
- Report all necessary repairs.

Unless other instructions are provided, perform the maintenance under the following conditions:

- The engine is stopped. Ensure that the engine cannot be started.
- Disconnect the batteries when maintenance is performed or when the electrical system is serviced. Disconnect the battery ground leads. Tape the leads in order to help prevent sparks.
- Disconnect the connector for the unit injector that is located on the valve cover base. This will help prevent personal injury from the high voltage to the unit injectors. Do not come in contact with the unit injector terminals while the engine is operating.
- Do not attempt any repairs that are not understood. Use the proper tools. Replace any equipment that is damaged or repair the equipment.

Pressurized Air and Water

Pressurized air and/or water can cause debris and/or hot water to be blown out. This could result in personal injury.

When pressurized air and/or pressurized water is used for cleaning, wear protective clothing, protective shoes, and eye protection. Eye protection includes goggles or a protective face shield.

The maximum air pressure for cleaning purposes must be below 205 kPa (30 psi). The maximum water pressure for cleaning purposes must be below 275 kPa (40 psi).

Fluid Penetration

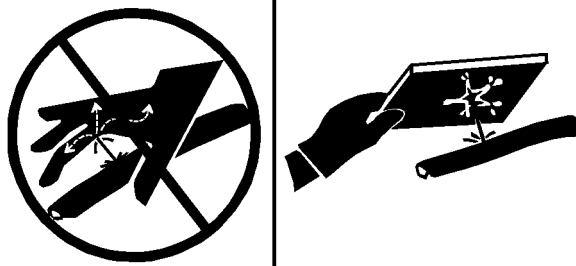

Illustration 7

g00687600

Always use a board or cardboard when you check for a leak. Leaking fluid that is under pressure can penetrate body tissue. Fluid penetration can cause serious injury and possible death. A pin hole leak can cause severe injury. If fluid is injected into your skin, you must get treatment immediately. Seek treatment from a doctor that is familiar with this type of injury.

Containing Fluid Spillage

Care must be taken in order to ensure that fluids are contained during performance of inspection, maintenance, testing, adjusting and repair of the engine. Prepare to collect the fluid with suitable containers before opening any compartment or disassembling any component that contains fluids.

Refer to Special Publication, NENG2500, "Caterpillar Dealer Service Tools Catalog" for the following items:

- Tools that are suitable for collecting fluids and equipment that is suitable for collecting fluids
- Tools that are suitable for containing fluids and equipment that is suitable for containing fluids

Obey all local regulations for the disposal of liquids.

Asbestos Information

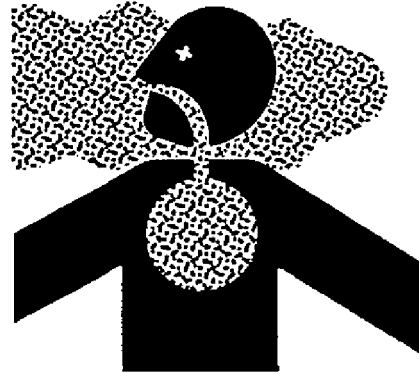

Illustration 8

g00702022

Caterpillar equipment and replacement parts that are shipped from Caterpillar are asbestos free. Caterpillar recommends the use of only genuine Caterpillar replacement parts. Use the following guidelines when you handle any replacement parts that contain asbestos or when you handle asbestos debris.

Use caution. Avoid inhaling dust that might be generated when you handle components that contain asbestos fibers. Inhaling this dust can be hazardous to your health. The components that may contain asbestos fibers are brake pads, brake bands, lining material, clutch plates, and some gaskets. The asbestos that is used in these components is usually bound in a resin or sealed in some way. Normal handling is not hazardous unless airborne dust that contains asbestos is generated.

If dust that may contain asbestos is present, there are several guidelines that should be followed:

- Never use compressed air for cleaning.
- Avoid brushing materials that contain asbestos.
- Avoid grinding materials that contain asbestos.
- Use a wet method in order to clean up asbestos materials.
- A vacuum cleaner that is equipped with a high efficiency particulate air filter (HEPA) can also be used.
- Use exhaust ventilation on permanent machining jobs.
- Wear an approved respirator if there is no other way to control the dust.

- Comply with applicable rules and regulations for the work place. In the United States, use Occupational Safety and Health Administration (OSHA) requirements. These OSHA requirements can be found in “29 CFR 1910.1001”.
- Obey environmental regulations for the disposal of asbestos.
- Stay away from areas that might have asbestos particles in the air.

Softwrap

Keep the engine room ventilation operating at full capacity. Wear a particulate respirator that has been approved by the National Institute of Occupational Safety and Health (NIOSH). Wear appropriate protective clothing in order to minimize direct contact. Use good hygiene practices and wash hands thoroughly after handling softwrap material. Do not smoke until washing hands thoroughly after handling softwrap material. Clean up debris with a vacuum or by wet sweeping. Do not use pressurized air to clean up debris.

Reference: The applicable material safety data sheets can be found at the following web site by searching by the part number or the name of the product:

<http://dsf2ws.cat.com/msds/servlet/cat.cis.ecs.msdsSearch.controller.UserIdentificationDisplayServlet>

Dispose of Waste Properly

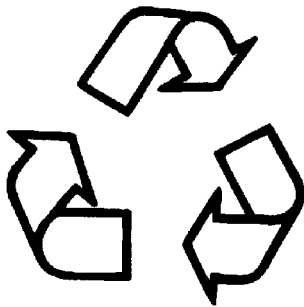

Illustration 9

g00706404

Improperly disposing of waste can threaten the environment. Potentially harmful fluids should be disposed of according to local regulations.

Always use leakproof containers when you drain fluids. Do not pour waste onto the ground, down a drain, or into any source of water.

Burn Prevention

SMCS Code: 1000; 4450; 7405

Do not touch any part of an operating engine. Allow the engine to cool before any maintenance is performed on the engine. Relieve all pressure in the air system, in the hydraulic system, in the lubrication system, in the fuel system, or in the cooling system before any lines, fittings or related items are disconnected.

Coolant

When the engine is at operating temperature, the engine coolant is hot. The coolant is also under pressure. The radiator and all lines to the heaters or to the engine contain hot coolant.

Any contact with hot coolant or with steam can cause severe burns. Allow cooling system components to cool before the cooling system is drained.

Check the coolant level after the engine has stopped and the engine has been allowed to cool.

Ensure that the filler cap is cool before removing the filler cap. The filler cap must be cool enough to touch with a bare hand. Remove the filler cap slowly in order to relieve pressure.

Cooling system conditioner contains alkali. Alkali can cause personal injury. Do not allow alkali to contact the skin, the eyes, or the mouth.

Oils

Hot oil and hot lubricating components can cause personal injury. Do not allow hot oil to contact the skin. Also, do not allow hot components to contact the skin.

Batteries

Electrolyte is an acid. Electrolyte can cause personal injury. Do not allow electrolyte to contact the skin or the eyes. Always wear protective glasses for servicing batteries. Wash hands after touching the batteries and connectors. Use of gloves is recommended.

i01496776

Fire Prevention and Explosion Prevention

SMCS Code: 1000; 4450; 7405



Illustration 10

g00704000

All fuels, most lubricants, and some coolant mixtures are flammable.

Flammable fluids that are leaking or spilled onto hot surfaces or onto electrical components can cause a fire. Fire may cause personal injury and property damage.

A flash fire may result if the covers for the engine crankcase are removed within fifteen minutes after an emergency shutdown.

Determine whether the engine will be operated in an environment that allows combustible gases to be drawn into the air inlet system. These gases could cause the engine to overspeed. Personal injury, property damage, or engine damage could result.

If the application involves the presence of combustible gases, consult your Caterpillar dealer for additional information about suitable protection devices.

Remove all flammable materials such as fuel, oil, and debris from the engine. Do not allow any flammable materials to accumulate on the engine.

All fluids that are captured in the fluid spill containment basin should be cleaned up immediately. Failure to clean up spilled fluids can cause a fire. Fire may cause personal injury and property damage.

Store fuels and lubricants in properly marked containers away from unauthorized persons. Store oily rags and any flammable materials in protective containers. Do not smoke in areas that are used for storing flammable materials.

Do not expose the engine to any flame.

Exhaust shields (if equipped) protect hot exhaust components from oil or fuel spray in case of a line, a tube, or a seal failure. Exhaust shields must be installed correctly.

Do not weld on lines or tanks that contain flammable fluids. Do not flame cut lines or tanks that contain flammable fluid. Clean any such lines or tanks thoroughly with a nonflammable solvent prior to welding or flame cutting.

Wiring must be kept in good condition. All electrical wires must be properly routed and securely attached. Check all electrical wires daily. Repair any wires that are loose or frayed before you operate the engine. Clean all electrical connections and tighten all electrical connections.

Eliminate all wiring that is unattached or unnecessary. Do not use any wires or cables that are smaller than the recommended gauge. Do not bypass any fuses and/or circuit breakers.

Arcing or sparking could cause a fire. Secure connections, recommended wiring, and properly maintained battery cables will help to prevent arcing or sparking.

Inspect all lines and hoses for wear or for deterioration. The hoses must be properly routed. The lines and hoses must have adequate support and secure clamps. Tighten all connections to the recommended torque. Leaks can cause fires.

Oil filters and fuel filters must be properly installed. The filter housings must be tightened to the proper torque.



Illustration 11

g00704059

Use caution when you are refueling an engine. Do not smoke while you are refueling an engine. Do not refuel an engine near open flames or sparks. Always stop the engine before refueling.

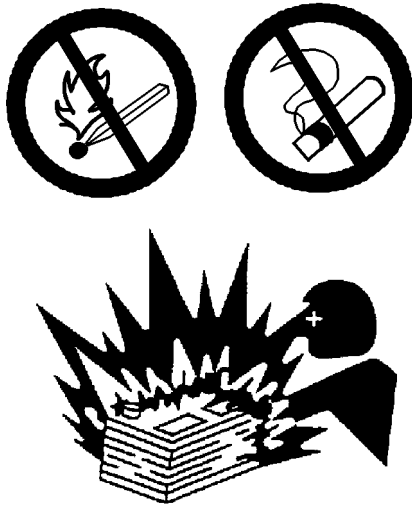

Illustration 12

g00704135

Gases from a battery can explode. Keep any open flames or sparks away from the top of a battery. Do not smoke in battery charging areas.

Never check the battery charge by placing a metal object across the terminal posts. Use a voltmeter or a hydrometer.

Improper jumper cable connections can cause an explosion that can result in injury. Refer to the Operation Section of this manual for specific instructions.

Do not charge a frozen battery. This may cause an explosion.

The batteries must be kept clean. The covers (if equipped) must be kept on the cells. Use the recommended cables, connections, and battery box covers when the engine is operated.

Fire Extinguisher

Make sure that a fire extinguisher is available. Be familiar with the operation of the fire extinguisher. Inspect the fire extinguisher and service the fire extinguisher regularly. Obey the recommendations on the instruction plate.

Ether

Ether is flammable and poisonous.

Use ether in well ventilated areas. Do not smoke while you are replacing an ether cylinder or while you are using an ether spray.

Do not store ether cylinders in living areas or in the engine compartment. Do not store ether cylinders in direct sunlight or in temperatures above 49 °C (120 °F). Keep ether cylinders away from open flames or sparks.

Dispose of used ether cylinders properly. Do not puncture an ether cylinder. Keep ether cylinders away from unauthorized personnel.

Do not spray ether into an engine if the engine is equipped with a thermal starting aid for cold weather starting.

Lines, Tubes and Hoses

Do not bend high pressure lines. Do not strike high pressure lines. Do not install any lines that are bent or damaged.

Repair any lines that are loose or damaged. Leaks can cause fires. Consult your Caterpillar dealer for repair or for replacement parts.

Check lines, tubes and hoses carefully. Do not use your bare hand to check for leaks. Use a board or cardboard to check for leaks. Tighten all connections to the recommended torque.

Replace the parts if any of the following conditions are present:

- End fittings are damaged or leaking.
- Outer coverings are chafed or cut.
- Wires are exposed.
- Outer coverings are ballooning.
- Flexible part of the hoses are kinked.
- Outer covers have embedded armoring.
- End fittings are displaced.

Make sure that all clamps, guards, and heat shields are installed correctly. During engine operation, this will help to prevent vibration, rubbing against other parts, and excessive heat.

i01359666

i01805780

Crushing Prevention and Cutting Prevention

SMCS Code: 1000; 4450; 7405

Support the component properly when work beneath the component is performed.

Unless other maintenance instructions are provided, never attempt adjustments while the engine is running.

Stay clear of all rotating parts and of all moving parts. Leave the guards in place until maintenance is performed. After the maintenance is performed, reinstall the guards.

Keep objects away from moving fan blades. The fan blades will throw objects or cut objects.

When objects are struck, wear protective glasses in order to avoid injury to the eyes.

Chips or other debris may fly off objects when objects are struck. Before objects are struck, ensure that no one will be injured by flying debris.

i01372247

Mounting and Dismounting

SMCS Code: 1000; 4450; 7405

Inspect the steps, the handholds, and the work area before mounting the engine. Keep these items clean and keep these items in good repair.

Mount the engine and dismount the engine only at locations that have steps and/or handholds. Do not climb on the engine, and do not jump off the engine.

Face the engine in order to mount the engine or dismount the engine. Maintain a three-point contact with the steps and handholds. Use two feet and one hand or use one foot and two hands. Do not use any controls as handholds.

Do not stand on components which cannot support your weight. Use an adequate ladder or use a work platform. Secure the climbing equipment so that the equipment will not move.

Do not carry tools or supplies when you mount the engine or when you dismount the engine. Use a hand line to raise and lower tools or supplies.

Before Starting Engine

SMCS Code: 1000

NOTICE

For initial start-up of a new or rebuilt engine, and for start-up of an engine that has been serviced, make provision to shut the engine off should an overspeed occur. This may be accomplished by shutting off the air and/or fuel supply to the engine.

Overspeed shutdown should occur automatically. If automatic shutdown does not occur, press the emergency stop button in order to cut the fuel and/or air to the engine.

Inspect the engine for potential hazards.

Before starting the engine, ensure that no one is on, underneath, or close to the engine. Ensure that the area is free of personnel.

If equipped, ensure that the lighting system for the engine is suitable for the conditions. Ensure that all lights work properly, if equipped.

All protective guards and all protective covers must be installed if the engine must be started in order to perform service procedures. To help prevent an accident that is caused by parts in rotation, work around the parts carefully.

Do not bypass the automatic shutoff circuits. Do not disable the automatic shutoff circuits. The circuits are provided in order to help prevent personal injury. The circuits are also provided in order to help prevent engine damage.

See the Service Manual for repairs and for adjustments.

i02136012

Engine Starting

SMCS Code: 1000

If a warning tag is attached to the engine start switch or to the controls, DO NOT start the engine or move the controls. Consult with the person that attached the warning tag before the engine is started.

All protective guards and all protective covers must be installed if the engine must be started in order to perform service procedures. To help prevent an accident that is caused by parts in rotation, work around the parts carefully.

If there is a possibility that unburned gas remains in the exhaust system, refer to the purge procedure in this Operation and Maintenance Manual, "Engine Starting" topic in the Operation Section.

Start the engine from the operator's compartment or from the engine start switch.

Always start the engine according to the procedure that is described in the Operation and Maintenance Manual, "Engine Starting" topic in the Operation Section. Knowing the correct procedure will help to prevent major damage to the engine components. Knowing the procedure will also help to prevent personal injury.

To ensure that the jacket water heater (if equipped) and/or the lube oil heater (if equipped) is working properly, check the water temperature and the oil temperature during heater operation.

Engine exhaust contains products of combustion which can be harmful to your health. Always start the engine and operate the engine in a well ventilated area. If the engine is started in an enclosed area, vent the engine exhaust to the outside.

Engine Stopping

i01462046

SMCS Code: 1000

Stop the engine according to the procedure in the Operation and Maintenance Manual, "Engine Stopping (Operation Section)" in order to avoid overheating of the engine and accelerated wear of the engine components.

Use the Emergency Stop Button (if equipped) ONLY in an emergency situation. Do not use the Emergency Stop Button for normal engine stopping. After an emergency stop, DO NOT start the engine until the problem that caused the emergency stop has been corrected.

Stop the engine if an overspeed condition occurs during the initial start-up of a new engine or an engine that has been overhauled. This may be accomplished by shutting off the fuel supply to the engine and/or shutting off the air supply to the engine.

To stop an electronically controlled engine, cut the power to the engine.

i02106213

Electrical System

SMCS Code: 1000; 1400

Never disconnect any charging unit circuit or battery circuit cable from the battery when the charging unit is operating. A spark can cause the combustible gases that are produced by some batteries to ignite.

To help prevent sparks from igniting combustible gases that are produced by some batteries, the negative "-" jump start cable should be connected last from the external power source to the negative "-" terminal of the starting motor. If the starting motor is not equipped with a negative "-" terminal, connect the jump start cable to the engine block.

Check the electrical wires daily for wires that are loose or frayed. Tighten all loose electrical wires before the engine is started. Repair all frayed electrical wires before the engine is started. See the Operation and Maintenance Manual for specific starting instructions.

Grounding Practices

Proper grounding for the engine electrical system is necessary for optimum engine performance and reliability. Improper grounding will result in uncontrolled electrical circuit paths and in unreliable electrical circuit paths.

Uncontrolled electrical circuit paths can result in damage to main bearings, to crankshaft bearing journal surfaces, and to aluminum components.

Engines that are installed without engine-to-frame ground straps can be damaged by electrical discharge.

To ensure that the engine and the engine electrical systems function properly, an engine-to-frame ground strap with a direct path to the battery must be used. This path may be provided by way of a starting motor ground, a starting motor ground to the frame, or a direct engine ground to the frame.

All grounds should be tight and free of corrosion. The engine alternator must be grounded to the negative "-" battery terminal with a wire that is adequate to handle the full charging current of the alternator.

i01593543

Generator Isolating for Maintenance

SMCS Code: 4450

When you service an electric power generation set or when you repair an electric power generation set, follow the procedure below:

1. Stop the engine.

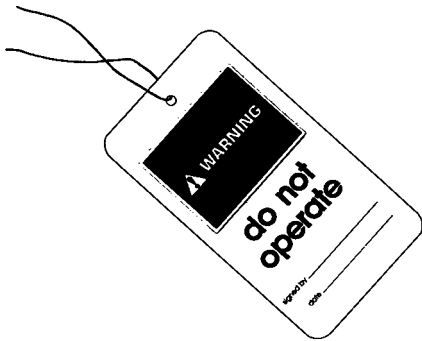

Illustration 13

g00104545

2. Attach a "DO NOT OPERATE" or similar warning tag to the engine prime mover starting circuit. Disconnect the engine starting circuit.
3. Disconnect the generator from the distribution system.
4. Lock out the circuit breaker. Attach a "DO NOT OPERATE" or similar warning tag to the circuit breaker. Refer to the electrical diagram. Verify that all points of possible reverse power flow have been locked out.
5. For the following circuitry, remove the transformer's fuses:
 - power
 - sensing
 - control
6. Attach a "DO NOT OPERATE" or similar warning tag to the generator excitation controls.
7. Remove the cover of the generator's terminal box.
8. Use an audio/visual proximity tester in order to verify that the generator is de-energized. This tester must be insulated for the proper voltage rating. Follow all guidelines in order to verify that the tester is operational.
9. Determine that the generator is in a de-energized condition. Add ground straps to the conductors or terminals. During the entire work period, these ground straps must remain connected to the conductors and to the terminals.

Product Information Section

Model Views and Specifications

i02455395

Model View Illustrations

SMCS Code: 1000; 4450

The following model views show typical features of the generator sets that are supported in this manual. Due to individual applications, your generator set may appear different from the illustrations.

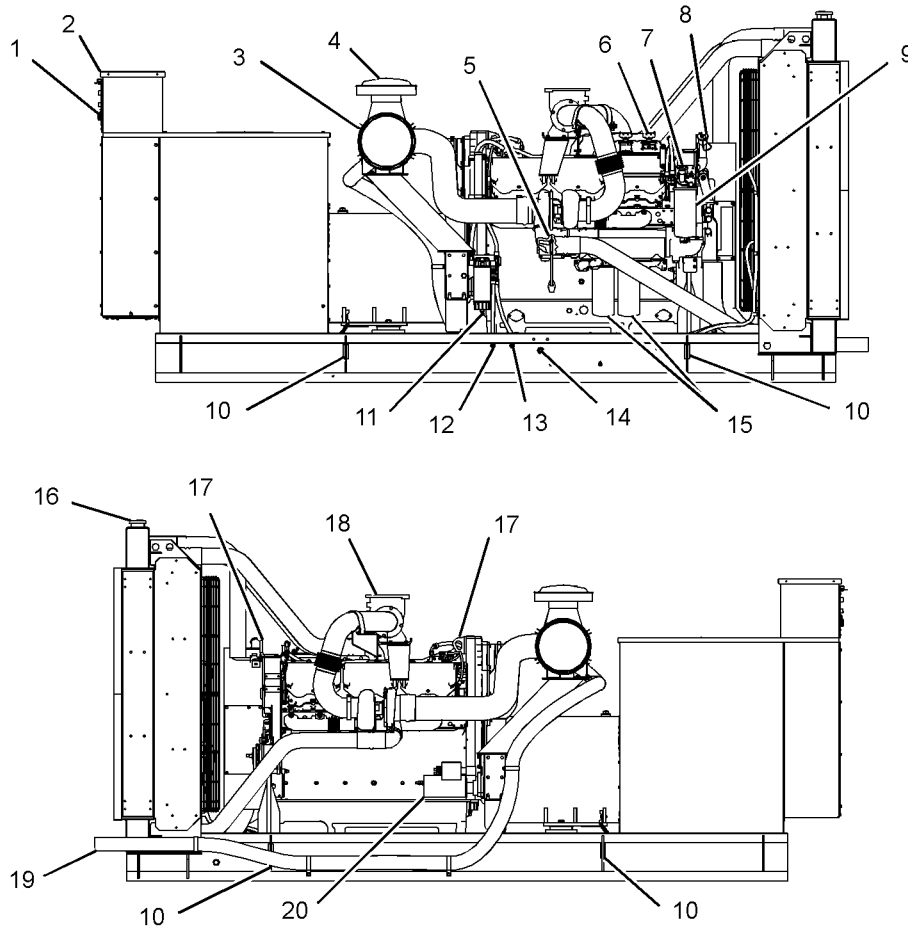

Illustration 14

g01225432

Typical example of a C27 generator set

- | | | |
|---------------------------------|--------------------------|--------------------------|
| (1) Emergency stop button | (8) Oil filler | (15) Oil filter |
| (2) Control panel | (9) Fuel filter | (16) Radiator cap |
| (3) Air cleaner | (10) Package lifting eye | (17) Engine lifting eye |
| (4) Air inlet | (11) Water separator | (18) Exhaust |
| (5) Oil level gauge | (12) Fuel inlet | (19) Fumes disposal tube |
| (6) Engine control module (ECM) | (13) Fuel return | (20) Starting motor |
| (7) Fuel priming pump | (14) Oil drain | |

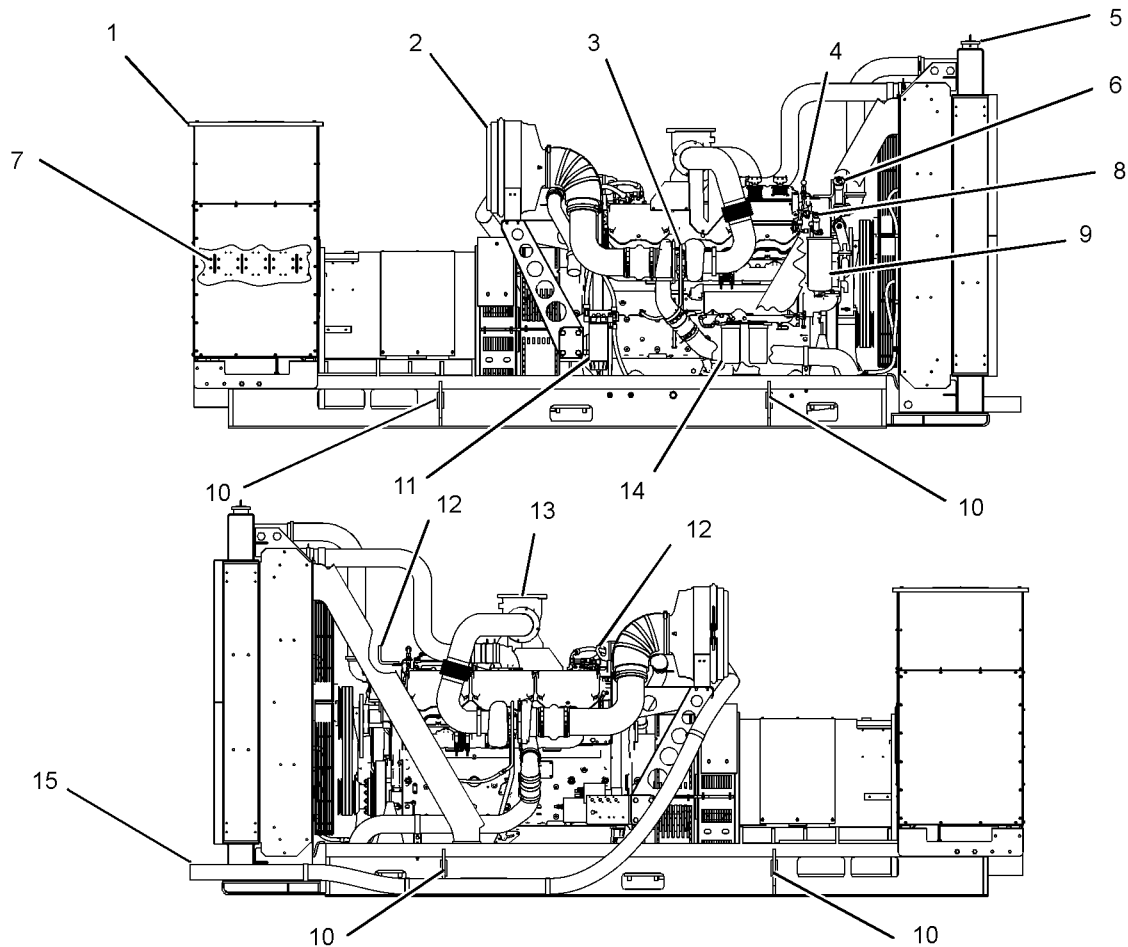

Illustration 15

g01185614

Typical example of a C32 generator set

- | | | |
|------------------------|--------------------------|--------------------------|
| (1) Control panel | (6) Oil filler | (11) Water separator |
| (2) Air cleaner | (7) Terminal strips | (12) Engine lifting eye |
| (3) Oil level gauge | (8) Fuel priming pump | (13) Exhaust |
| (4) Excess fuel return | (9) Fuel filter | (14) Oil filter |
| (5) Radiator cap | (10) Package lifting eye | (15) Fumes disposal tube |

i02572751

Product Description

SMCS Code: 1000; 4450

Caterpillar C27 and C32 Generator Sets provide the following features:

Engine Description

- Four cycle
- Direct fuel injection
- Mechanical Electronic Unit Injector (MEUI)
- Turbocharged

- Air-To-Air Aftercooler (ATAAC)

Electronic Engine Features

Caterpillar C27 and C32 engines are designed with electronic controls. The integral on board computer controls the operation of the engine. Current operating conditions are monitored. The Electronic Control Module (ECM) controls the response of the engine to these conditions and to the demands of the operator. These conditions and operator demands determine the precise control of fuel injection by the ECM. The electronic engine control system provides the following features:

- Engine and auxiliary monitoring
- Engine speed governing

- Cold start strategy
- Automatic air/fuel ratio control
- Integrated ether start
- Torque rise shaping
- Automatic altitude compensation
- Injection timing control
- System diagnostics

For more information on electronic engine features, refer to the Operation and Maintenance Manual, "Features and Controls" topic (Operation Section).

Engine Cooling and Lubrication

The cooling system consists of the following components:

- Gear-driven centrifugal water pump
- Water temperature regulators which regulate the engine coolant temperature
- Gear-driven oil pump (gear type)
- Oil cooler

The engine lubricating oil is also filtered. Bypass valves provide unrestricted flow of lubrication oil to the engine components during the following conditions:

- High oil viscosity
- Plugged oil cooler or plugged oil filter elements (paper cartridge)

Engine Service Life

Engine efficiency and maximum utilization of engine performance depend on the adherence to proper operation and maintenance recommendations. In addition, use recommended fuels, coolants and lubricants. Use this Operation and Maintenance Manual as a guide for required engine maintenance.

Expected engine life is generally predicted by the average power that is demanded. The average power that is demanded is based on fuel consumption of the engine over a period of time. For more information, refer to the Operation and Maintenance Manual, "Overhaul Considerations" topic (Maintenance Section).

Engine Specifications

Note: The front end of the engine is opposite the flywheel end of the engine. The left and the right sides of the engine are determined from the flywheel end. The number 1 cylinder is the most forward cylinder.

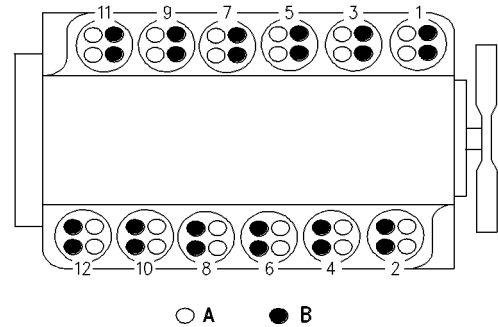

Illustration 16

g00291566

Cylinder and valve locations

- (A) Inlet valves
(B) Exhaust valves

Table 1

C27 and C32 Generator Set Engine Specifications		
	C27	C32
Cylinders and Arrangement	12 cylinder vee block	
Bore	137.7 mm (5.4 inch)	145 mm (5.7 inch)
Stroke	152.4 mm (6 inch)	162 mm (6.4 inch)
Compression Ratio	16.5:1	15:1
Aspiration	TA ⁽¹⁾	
Displacement	27 L (1648 in ³)	32 L (1953 in ³)
Firing Order	1-10-9-6-5-12-11-4-3-8-7-2	
Rotation (flywheel end)	Counterclockwise	

⁽¹⁾ Turbocharged Aftercooled

Generator Description

The SR4B brushless generator is used with the following loads: mixed loads of motors and lights, SCR-controlled equipment, computer centers, installations of communications, and petroleum drilling applications. The elimination of the brushes in the field circuit reduces maintenance. The elimination of the brushes in the field circuit increases reliability. The elimination of brushes provides a higher degree of protection in potentially hazardous atmospheres.

The generator set packages can be utilized for prime power generation or standby power generation. The generator set packages can be used in land-based applications or marine applications.

SR4B generators are utilized in three-phase full-wave excitation and regulation. The generators have four poles. The generators have four, six, ten, or twelve lead configuration. This depends on frame size. The generators are capable of producing electrical power in either 50 Hz or 60 Hz applications.

Product Identification Information

i02456200

Plate Locations and Film Locations

SMCS Code: 1000; 4450

Caterpillar generator sets are identified by serial numbers and by arrangement numbers. These numbers are shown on the engine serial number plate, on the engine identification plate and on the generator identification plate. Caterpillar dealers need these numbers in order to determine the components that were included with the engine. This permits accurate identification of replacement part numbers.

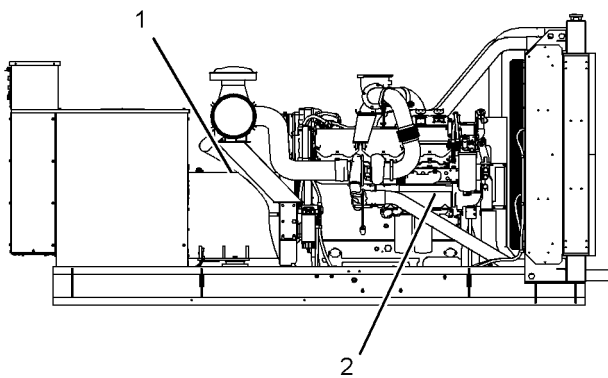

Illustration 17
C27 generator set

g01225493

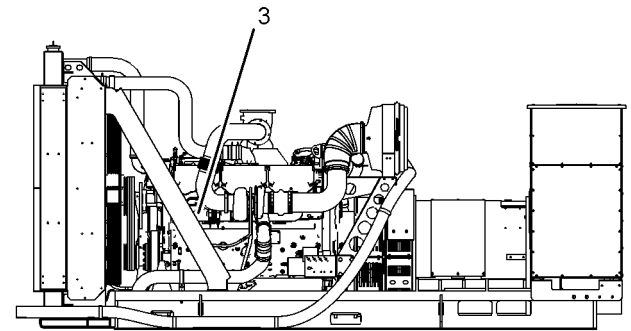
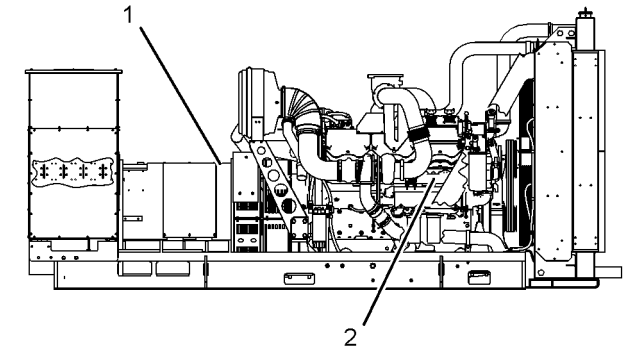
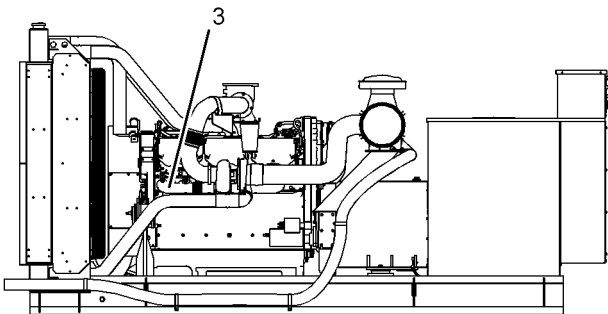

Illustration 18
C32 generator set

g01225784

Generator Identification Plate (1)

The generator identification plate is located on the top of the barrel of the generator.

Generator serial number _____

Generator model number _____

Engine Identification Plate (2)

The engine identification plate is located on the right side of the engine on the oil cooler.

Setpoint of the engine altitude derate _____

Horsepower _____

High idle _____

Full load engine speed _____

Fuel settings _____

The engine information plate also contains other important information about the engine.

Engine Serial Number Plate (3)

The engine serial number plate is located on the left side of the engine block.

Engine serial number _____

Engine model _____

Arrangement number _____

i01830750

Emissions Certification Film

SMCS Code: 1000; 7405

Note: This information is pertinent in the United States, in Canada and in Europe.

A typical example is shown.

CATERPILLAR INC.		IMPORTANT ENGINE INFORMATION			2000	JDM00001	
ENGINE MODEL : 3116 - DISPLACEMENT : 6.6L - VALVE LASH : 0.38mm INTAKE 0.64mm EXHAUST							
CAT	ENGINE FAMILY XCPXL06.6MFB	MAXIMUM ADVERTISED kW (HP) 164 (220)	MAXIMUM RATED SPEED (RPM) 2600	MAXIMUM LOW IDLE SPEED (RPM) 875	MAX. FUEL RATE @MAXIMUM (mm³/STROKE) 104	MAXIMUM INITIAL TIMING DEGREES BTDC 11.5	EXHAUST EMISSION CONTROL SYSTEM EM,DI,TC,SPL,CAC
THIS 3116 ENGINE CONFORMS TO DIRECTIVE 97/68/EC FOR NON-ROAD ENGINES.				EC TYPE APPROVAL NO. eIRL*97/68AA*0001*00			
THIS 3116 ENGINE CONFORMS TO 2000 U.S. EPA AND CALIFORNIA REGULATIONS LARGE NON-ROAD COMPRESSION-IGNITION ENGINES.							
THIS ENGINE IS CERTIFIED TO OPERATE ON COMMERCIALY AVAILABLE DIESEL FUEL.							
DATE OF MANUFACTURE MONTH : 08						7E-8050 01	

FMT:3500

The EPA/EU Emissions Certification Film (if applicable) is located either on the side, the top, or the front of the engine.

CATERPILLAR INC.		INFORMATION IMPORTANTE SUR LE MOTEUR				
MODÈLE MOTEUR : 3116 - DÉBIT : 6,6 l - JEU SOUPAPES : 0,38 mm ADMISSION : 0,64 mm ÉCHAPPEMENT						
FAMILLE DE MOTEURS : XCPXL06.6MFB	Kw (HP) MAXI PUBLIES : 164 (220)	MAXI RÉGIME NOMINAL (tr/mn) : 2600	MAXI RÉGIME RALENTI (tr/mn) : 875	MAXI DÉBIT D'INJ. À PUIS. MAXI (mm³/STROKE) (PISTON) : 104	MAXI CALAGE INITIAL D'INJ. (DEGRÉS) (AVANT PMH) : 11.5	DISPOSITIF ANTI-POLLUANT : EM,DI,TC,SPL,CAC
CE MOTEUR 3116 EST CONFORME AUX DIRECTIVES 97/68/EC POUR LES MOTEURS NON ROUTIERS.				NO APPROBATION TYPE EC eIRL*97/68AA*0001*00		
CE MOTEUR 3116 EST CONFORME AUX RÉGLEMENTATIONS 2000 DE L'AGENCE AMÉRICAINE DE PROTECTION DE L'ENVIRONNEMENT (EPA) ET DE LA CALIFORNIE POUR LES GROS MOTEURS NON ROUTIERS À COMPRESSION-CONTACT.						
CE MOTEUR EST HOMOLOGUÉ POUR FONCTIONNER AVEC LE CARBURANT DIESEL DU COMMERCE.						
DATE DE FABRICATION (MOIS) 08						

Étiquette d'homologation anti-pollution

L'autocollant d'homologation du dispositif antipollution EPA/EU (selon équipement) est situé soit sur le côté du moteur, soit sur le dessus du moteur, soit sur le devant du moteur.

Illustration 19

g00776690

i01757910

Reference Information

SMCS Code: 1000; 4450

Identification of the following items may be needed in order to obtain parts and service. Some of the numbers are on the engine Serial Number Plate and/or Information Plate. Locate the information for your engine. Record the information in the appropriate space. Make a copy of this list for a record. Retain the information for future reference.

The top level part numbers in the Parts Manual for the engine are listed with the engine arrangement number.

The packaging arrangement may also be called a pricing arrangement or a customer arrangement. This is the total package with attachments and options that are not included in the engine arrangement.

The performance specification can be used by your Caterpillar dealer with the Technical Marketing Information system. Before the engine leaves the factory, the engine performance is tested. Detailed performance data is recorded. The performance specification number can be used for obtaining the data.

Record for Reference

Engine Model _____

Engine Serial Number _____
Engine Arrangement Number _____
Modification Number _____
Engine Low Idle rpm _____
Engine Full Load rpm _____
Performance Specification Number _____
Part Number for the Primary Fuel Filter _____
Part Number for the Water Separator Element _____
Part Number for the Secondary Fuel Filter Element _____
Part Number for the Lubrication Oil Filter Element _____
Part Number for the Auxiliary Oil Filter Element _____
Part Number for the Supplemental Coolant Additive Maintenance Element (If Equipped) _____
Total Lubrication System Capacity _____
Total Cooling System Capacity _____
Part Number for the Air Cleaner Element _____
Part Number for the Fan Drive Belt _____
Part Number for the Alternator Belt _____
Model Number of the Generator _____
Serial Number of the Generator _____
Arrangement Number of the Generator _____
Part Number for the Control Panel _____

The leads are numbered clockwise from the top and from the outside inward. The diagrams that are contained in the “Wye Configuration Diagrams” section show lead numbering for the six lead generators and for the twelve lead generators. The diagrams contained in the “Delta Configuration Diagrams” section show lead numbering for the six lead generators and for the twelve lead generators.

Wye Configuration Diagrams

6 Lead

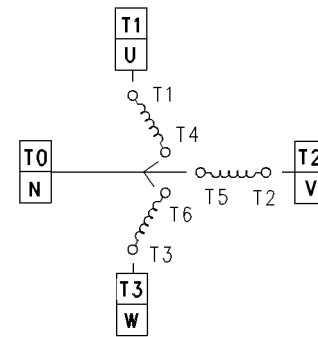

Illustration 20

g00611486

6 Lead Wye Configuration

Terminals T4, T5 and T6 become a neutral connection when the terminals are tied together.

i01553111

Generator Lead Connections

SMCS Code: 4450

Lead Numbering

The Wye Configurations and the Delta Configurations are the most common generator lead connections. The following three-phase connection diagrams illustrate the proper connection and lead identification.

12 Lead

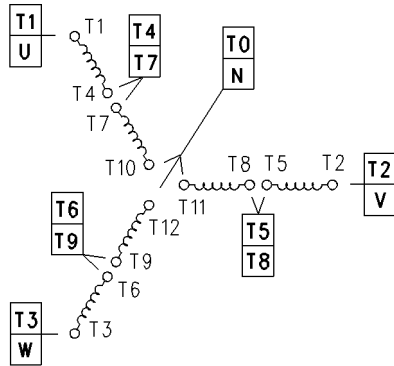

Illustration 21 g00661863
12 Lead Wye Configuration - High Voltage
Terminals T10, T11 and T12 become neutral connection when the terminals are tied together.

Delta Configuration Diagrams

6 Lead

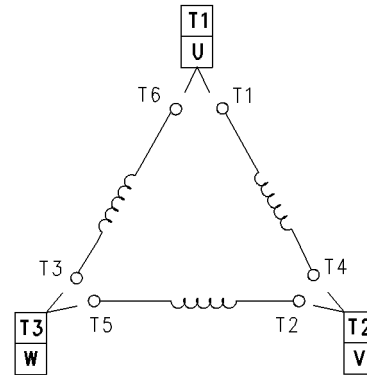

Illustration 23 g00669319
6 Lead Delta Configuration

12 Lead

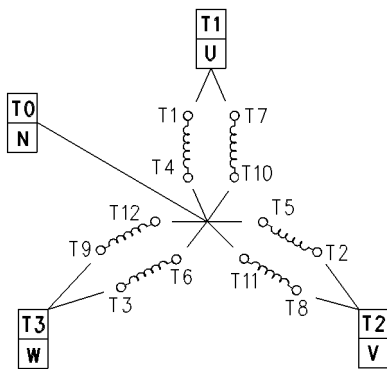

Illustration 22 g00611608
12 Lead Wye Configuration - Low Voltage
Terminals T10, T11 and T12 become neutral connection when the terminals are tied together.

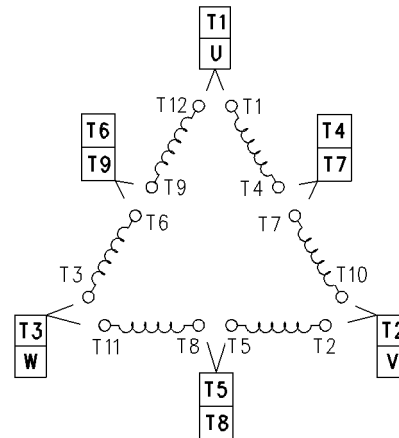

Illustration 24 g00669312
12 Lead Delta Configuration
Terminals T6 and T9 become the neutral connection when the terminals are tied together and grounded. This reflects the terminal T2 and T10 connection as the high phase.

Grounding the Frame

In any generator set installation, the frame of the generator must be positively connected to an earth ground or to the hull of a vessel. This connection is the first connection that is made at the installation. This connection is the last connection that should be removed. If the generator set is on flexible pads or on resilient pads, the ground connection must be flexible in order to avoid possible breakage in later operation.

Ground connection cable or ground connection straps should have at least the current carrying capacity of the largest line lead to the connected load. Joints in cables or in straps must be clean, free of electrical resistance, and protected from possible oxidation. Bolted ground connection joints eventually oxidize. The joints are frequent sources of radio frequency interference (RFI). Silver soldered joints and bolted joints are electrically and mechanically sound.

Neutral Connections

The generators with Wye Configuration usually have the neutral ground when the generator is installed. However, there are some cases when definite measures should be taken in order to prevent grounds on the load side. The purpose of the grounding of the neutral is to prevent load side equipment damage.

If the neutral wire is grounded and one of the phase leads becomes grounded, the excessive current will open a load circuit breaker. The excessive current will also collapse the generator voltage. The result depends on the following items: particular generator electrical characteristics, type of fault, and trip rating of the circuit breaker. An undervoltage device may be required in order to provide an adequate short circuit protection.

There are some instances in which it is undesirable to ground the neutral wire. In other applications, it is acceptable to have an ungrounded generator neutral lead. Definite measures should be taken in such applications in order to prevent grounds to the phase leads. An example of such measures are ground fault protective circuits. Ground fault protection requires that the entire group of distribution circuits should be studied. The entire group of distribution circuits should be treated as a system. The owner should engage a certified, registered consultant if a new distribution system is being developed. The owner should also engage a certified, registered consultant if an existing system should be modified for the ground fault protection.

Single Units

In a three-phase, four-wire system, the neutral wire should be grounded according to local wiring codes.

In applications in which definite measures are taken in order to prevent grounds to the load leads, an ungrounded neutral can be used. Be sure to check your local wiring codes.

Multiple Units

Operation of multiple generators in parallel that have all neutrals grounded, may result in the circulating current through the neutral connections. In order to eliminate the possibility of circulating currents, ground the neutral of only one generator. If multiple generators are alternated on line, a switch should be installed in the neutral ground circuit of each generator. In this case, all neutral ground circuits except one circuit can be opened. Be sure that one of the neutral ground circuits is closed.

Parallel to Utility

When a Wye connected generator is going to operate in parallel with a utility system (infinite bus) and when the secondary of the step-down transformer in the utility system is also a Wye connection, the following may happen. The grounding of both Wye neutrals may result in circulating currents through the neutrals. Also, the coordination of ground fault protection requires an entire system study. This study should be done by a certified, registered consultant who is familiar with generator systems. The study will determine which grounding method should be used.

i01553204

Voltage Connections

SMCS Code: 4450

Three-Phase Voltage Connections

The Wye Configuration for a 480 V generator and the Delta Configuration for a 240 V generator are given in the following diagrams.

The terminals must be connected securely. The terminals must also be insulated with a good quality electrical tape.

If a Delta Configuration with grounded neutral is being used, a two-thirds winding pitch is recommended. If the generator winding pitch is not two-thirds, third harmonics will cause a high neutral current. This current can damage the wiring, which may cause a fire hazard. A floating neutral does not require a two-thirds pitch winding.

Wye Configuration Diagrams

6 Lead Generators

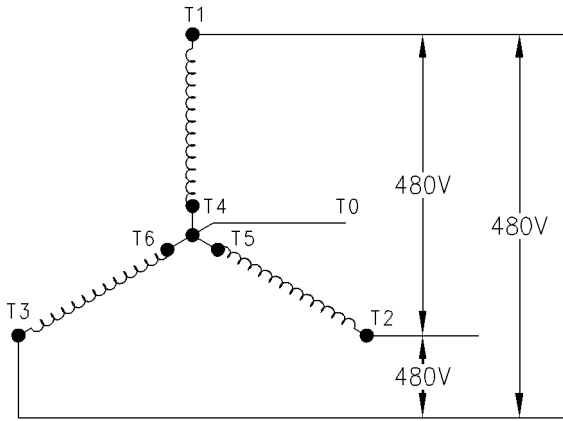

Illustration 25 g00626053
Typical Wye Configuration (60 Hz, 6 Lead)

12 Lead Generators

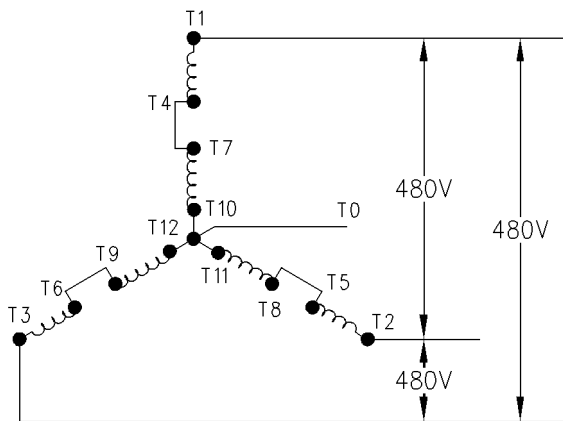

Illustration 26 g00637319
Typical Series Wye Configuration (60 Hz, 12 Lead)
This is a typical high voltage connection.

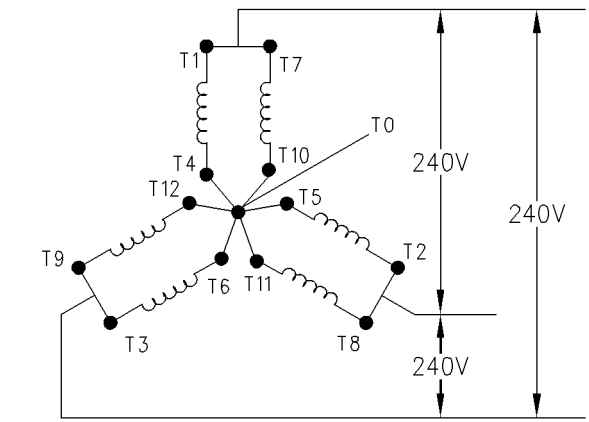

Illustration 27 g00637320
Typical Parallel Wye Configuration (60 Hz, 12 Lead)
This is a typical high voltage connection.

Delta Configuration Diagrams

6 Lead Generators

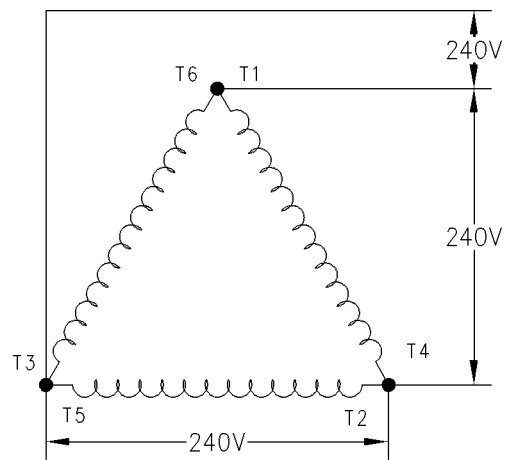

Illustration 28 g00626129
Typical Delta Configuration (60 Hz, 6 Lead)

12 Lead Generators

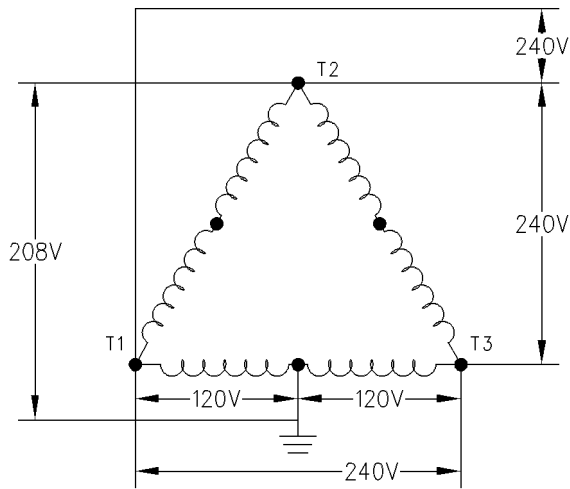

Illustration 29
 Typical Delta Configuration (60 Hz, 12 Lead) g00626130

Single-Phase Current From a Three-Phase Generator

Three-phase current and single-phase current can be taken simultaneously from a generator that is connected for three-phase service. In the Wye Configuration, connect the load to the three-phase leads (any two of the three leads). In the Delta Configuration, connect the load to the three-phase leads (any two of the three leads). In both configurations, this connection will provide single-phase voltage at the same voltage as three-phase voltage.

Connect the load to any phase lead and neutral lead of the Wye Configuration. This will produce voltage at 58% of three-phase voltage.

In the Delta Configuration that produces 240 Volts 60 Hz three-phase power, the voltages will be the following:

- 208 Volts between the high phase and neutral
- 240 Volts between either one of the low phases and neutral

Refer to Operation Section, "Generator Operation" for allowable single-phase loading unbalance.

Single-phase power that is taken from a three-phase source can be a problem. Ensure that the single-phase loading is equally distributed.

Do not exceed the nameplate current rating for any one phase.

Wye Configuration Diagrams

6 Lead Generators

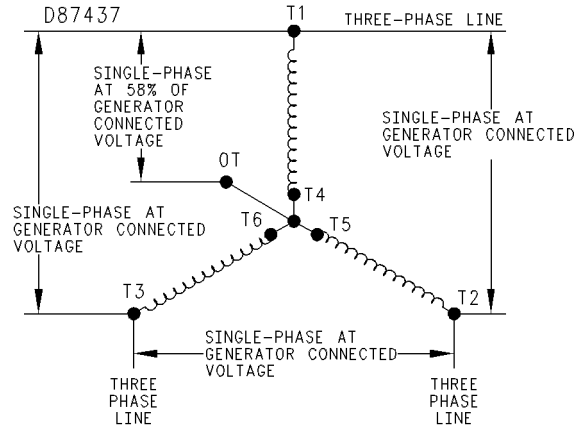

Illustration 30
 Single-Phase Voltage Diagram with 6 Lead Wye Configuration g00626132

12 Lead Generators

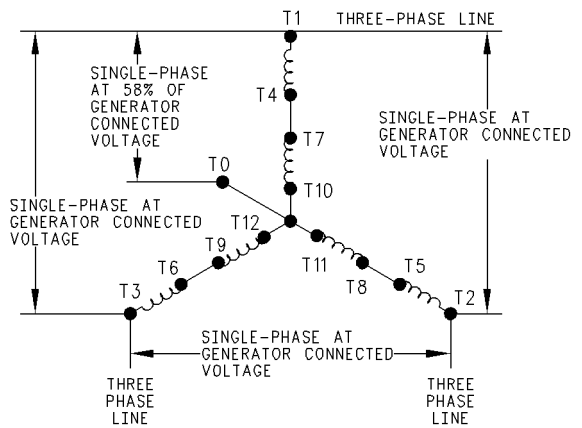

Illustration 31
 Single-Phase Voltage Diagram with 12 Lead Wye Configuration g00637321

Delta Configuration Diagrams

6 Lead Generators

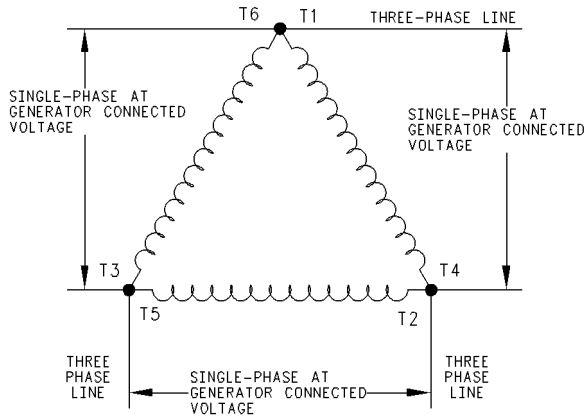

Illustration 32 g00626135
 Single-Phase Voltage Diagram with 6 Lead Delta Configuration

12 Lead Generators

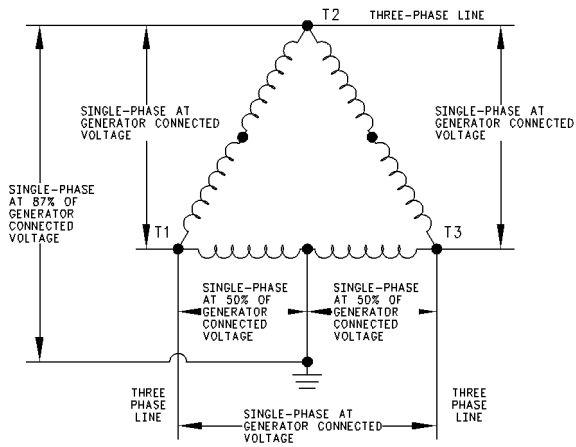

Illustration 33 g00626136
 Single-Phase Voltage Diagram with 12 Lead Delta Configuration

Operation Section

Lifting and Storage

Product Lifting

i02396283

SMCS Code: 7000; 7002

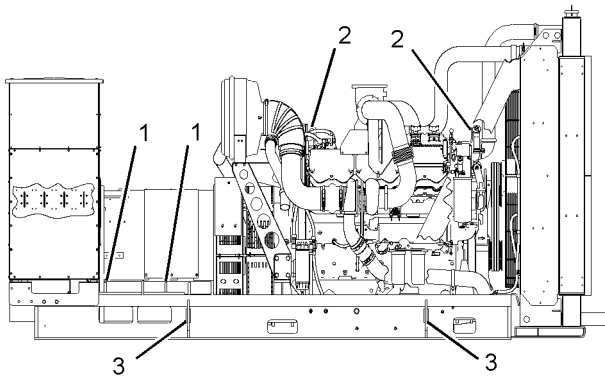

Illustration 34

g01189078

NOTICE

Never bend the eyebolts and the brackets. Only load the eyebolts and the brackets under tension. Remember that the capacity of an eyebolt is less as the angle between the supporting members and the object becomes less than 90 degrees.

When it is necessary to remove a component at an angle, only use a link bracket that is properly rated for the weight.

Use a hoist to remove heavy components. Use an adjustable lifting beam to lift the entire package. Use an adjustable lifting beam to lift the engine. All supporting members (chains and cables) should be parallel to each other. The chains and cables should be perpendicular to the top of the object that is being lifted.

Some removals require lifting fixtures in order to obtain proper balance. Lifting fixtures also help to provide safety.

Lifting eyes are designed and installed for each package. Alterations to the lifting eyes and/or the package make the lifting eyes and the lifting fixtures obsolete. If alterations are made, ensure that proper lifting devices are provided. Consult your Caterpillar dealer for information regarding fixtures for proper lifting.

Lifting the Entire Package

Do NOT use the engine lifting eyes or the generator lifting eyes to lift the entire package. Lifting points (3) have been provided on the base rails of the generator set for lifting the entire package. However, lifting the engine and the generator together requires special equipment and procedures. Consult your Caterpillar dealer for information regarding fixtures for proper lifting of your complete package.

Lifting the Engine Only

To remove the engine ONLY, use lifting eyes (2) that are on the engine.

Lifting the Generator Only

Note: The control panel and the terminal will need to be removed before attempting to lift the generator.

To remove the generator ONLY, use lifting eyes (1) that are on the generator.

i02068367

Product Storage

SMCS Code: 7002

If the engine will not be started for several weeks, the lubricating oil will drain from the cylinder walls and from the piston rings. Rust can form on the cylinder liner surface. Rust on the cylinder liner surface will cause increased engine wear and a reduction in engine service life.

To help prevent excessive engine wear, use the following guidelines:

- Complete all of the lubrication recommendations that are listed in this Operation and Maintenance Manual, "Maintenance Interval Schedule" (Maintenance Section).
- If freezing temperatures are expected, check the cooling system for adequate protection against freezing. See this Operation and Maintenance Manual, "Refill Capacities and Recommendations" (Maintenance Section).

If an engine is out of operation and if use of the engine is not planned, special precautions should be made. If the engine will be stored for more than one month, a complete protection procedure is recommended.

For more detailed information on engine storage, see Special Instruction, SEHS9031, "Storage Procedure For Caterpillar Products".

Your Caterpillar dealer can assist in preparing the engine for extended storage periods.

Installation

i01856938

Generator Set Installation

SMCS Code: 7002

Receiving Inspection

If the generator is received during cold weather, allow the unit to reach room temperature before you remove the protective packing material. Warming the generator to room temperature will prevent the following problems:

- Water condensation on cold surfaces
- Early failures due to wet windings
- Early failures due to wet insulating materials

Unpacking and Storage

Moving the Generator



Improper lift rigging can allow unit to tumble causing injury and damage.

NOTICE

Do not use the engine lifting eyes to remove the engine and generator together.

Unpack the equipment with care in order to avoid scratching painted surfaces. Move the unit to the mounting location. The unit can be moved by either of the following methods:

- Attach an overhead crane to the lifting eyes that are installed on the generator package.
- Use a lift truck in order to lift the generator.

The hoist and the hoist cables should have a rating that is greater than the weight of the generator. When the unit is moved, ensure that the generator is completely supported by the lift truck's fork tines. Also ensure that the generator is balanced on the lift truck's fork tines. Slide the fork tines beneath the attached skid in order to lift the generator.

Storage

Short Time Storage

If the generator is not installed immediately, store the generator in a clean area. This area should also have the following conditions: low humidity, stable humidity, and stable temperature. Space heaters must be energized in order to keep condensation from the windings. All accessory equipment that is supplied with the unit should be stored with the generator. The combined unit should be covered with a durable cover in order to protect against the following contaminants:

- Dust
- Dirt
- Moisture

Long Time Storage

A storage period in excess of six months should be preceded by the following preparation:

1. Install desiccant bags inside the exciter's cover and install desiccant bags inside the screen of the fan.
2. Seal the unit in a covering of plastic or other material that has been designed for that purpose.
3. Adequately tag the generator. This will ensure that preservative greases and desiccant bags are removed before the unit is placed in operation.

Bearing Inspection

Ball bearing generators use grease. This grease is subject to deterioration. If the generator is stored longer than one year, new ball bearings should be installed. These bearings should be greased to the proper level prior to being put into operation. If inspection indicates that bearings are free of rust or corrosion, and no noise or excessive vibration appear on start-up, replacement is not necessary.

Location

The location of the generator must comply with all local regulations. The location of the generator must also comply with all special industrial regulations. Locate the generator in an area that meets the following requirements:

- Clean
- Dry

- Well ventilated
- Easily accessible for inspection and maintenance

Do not obstruct air inlet openings. Do not obstruct discharge openings. Coolant flow must reach these openings. If the generator is exposed to harsh environmental conditions, the generator can be modified in the field in order to add filters and space heaters. In addition, a more rigid periodic maintenance schedule should be established.

Electrical Measurements

Measure the insulation resistance of each winding if the generator was exposed to the following conditions:

- Rapid changes in temperature
- Freezing
- Wet climate during shipment
- Wet climate during storage

Note: These tests should be conducted prior to any power connections that are being made. These tests should be conducted prior to any control connections that are being made.

Refer to the Generator Maintenance section of this manual in order to measure the following items:

- Exciter field (stator)
- Exciter armature (rotor)
- Generator field (rotor)
- Generator armature (stator)

Alignment

After the generator set has been placed in the final position, the generator must be aligned. Refer to these publications:

- Special Instruction, SEHS7654, "Alignment - General Instructions"
- Special Instruction, SEHS7259, "Alignment of Single-Bearing Generators"
- Special Instruction, REHS0177, "Alignment of the Close Coupled Two-Bearing Generators"

Protective Devices

The output to the load of the generator should always be protected with an overload protection device such as a circuit breaker or fuses. Fuses should be sized by using the lowest possible current rating. However, this rating must be above the current rating for full load. A common recommendation is 115 percent of rated current. Determine the size of fuses or determine the size of circuit breakers in accordance with NEMA, IEC, and Local Electrical Codes.

Features and Controls

i02363871

Electronic Modular Control Panel II+ with Paralleling (EMCP II+P) (If Equipped)

SMCS Code: 4490

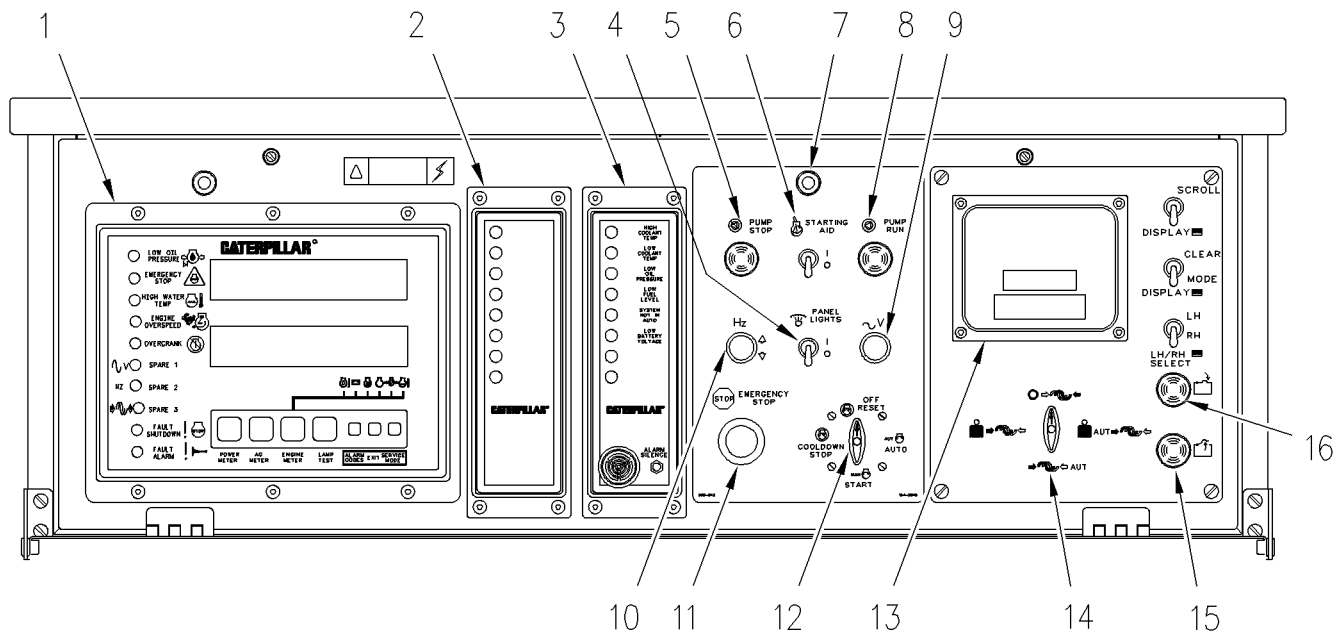

Illustration 35

g00639524

Electronic Modular Control Panel II+ With Paralleling (EMCP II+P)

- | | | |
|---------------------------------------|---|---|
| (1) Generator set control + (GSC+) | (7) Panel lights (PL) | (12) Engine control switch (ECS) |
| (2) Alarm module (ALM) (optional) | (8) Pump run switch (optional) | (13) Caterpillar Monitoring System |
| (3) Custom alarm module (CAM) | (9) Voltage adjust rheostat (VAR) | (14) Synchronization mode switch |
| (4) Panel light switch (PLS) | (10) Speed potentiometer (SP) (optional) or Governor switch (GS) (optional) | (15) Breaker open pushbutton/indicator |
| (5) Pump stop switch | (11) Emergency stop push button (ESP) | (16) Breaker close pushbutton/indicator |
| (6) Start aid switch (SAS) (optional) | | |

The electronic modular control panel II+ with paralleling (EMCP II+P) is located above the generator distribution housing. The control panel consists of a main panel with indicators, meters and control switches. This control panel may be equipped with optional modules in order to match the customers' needs and requirements.

The left side of the control panel contains the generator set control + (GSC+). This is the main component of the system. The GSC+ displays generator output, fault conditions, and key engine parameters. The center section of the control panel may be blank, or contain one or two of the optional alarm modules. The right side of the control panel may be blank, or contain the Caterpillar Monitoring System.

The main control panel may or may not contain all of the components which are shown in Illustration 35. Some components are optional. The optional components may not be required for your particular application.

Generator Set Control + (1) – The generator set control + (GSC+) is the main component of the EMCP II+P. See the topic “Generator Set Control + (GSC+)” in this section.

Alarm Module (2) – The alarm module (ALM) is optional. The function of the ALM is to provide a visual and audible warning of engine conditions before these conditions become severe enough to shut the engine down or keep the engine from starting.

Custom Alarm Module (3) – The custom alarm module (CAM) is optional. The purpose of the CAM is to annunciate faults, alarms or other conditions from customer supplied inputs.

Panel Light Switch (4) – The panel lights switch (PLS) turns the panel lights (7) on or off.

Pump Stop Switch (5) – The pump stop switch is optional with 3406E and 3412C generator sets only. This push button switch is used with the generator mounted automatic fuel transfer system, if equipped. The pump stop switch is used to manually stop the fuel transfer pump. This switch is latched down when pushed. The red indicator will now be ON. The switch can be reset by pressing the switch again. The red indicator will now be OFF.

Start Aid Switch (6) – The start aid switch (SAS) is optional. The SAS is used to inject ether into the engine when you are starting the engine in cold weather conditions. When the SAS is in the ON position, the switch energizes the starting aid solenoid valve (SASV) and meters a specific amount of ether into a holding chamber. When the SAS is released, the solenoid releases the ether to the engine.

NOTICE

The engine must be cranking before using the start aid switch. Damage to the engine is possible if ether is released to the engine but not exhausted or burned by the engine when cranking.

Panel Lights (7) – Panel lights (PL) are controlled by the panel lights switch (4). The panel lights switch (4) is an ON/OFF switch.

Pump Run Switch (8) – The pump run switch is optional. This momentary push button switch is used with the generator set mounted automatic fuel transfer system, if equipped. Pushing this switch will cause the generator set mounted fuel transfer pump to fill the generator set day tank. The green indicator will be ON when the pump is running. The pump will automatically shut OFF when the fuel reaches the high fuel level. The pump can also be turned OFF manually by the pump stop switch (5). The pump stop switch must be reset. Reset the pump stop switch by pressing the switch again.

Voltage Adjust Rheostat (9) – The voltage adjust rheostat (VAR) is used to adjust the generator output voltage to the desired level.

Speed Potentiometer (10) – The speed potentiometer (SP) is optional. The SP can be used with the generator set that has an electric governor. When the governor is equipped with a speed adjust motor, the governor switch (GS) can be mounted instead of the SP. The GS is used to raise or lower the engine speed and frequency. The GS is also optional.

Emergency Stop Push Button (11) – The emergency stop push button (ESPB) is used to shut down the engine during an emergency situation. The ESPB shuts off the fuel and activates the optional air shutoff, if equipped.

Engine Control Switch (12) – The engine control switch (ECS) determines the status of the control panel. In the AUTOMATIC position (3 o'clock), the engine will start automatically whenever a remote initiating contact is closed. The engine will shutdown after the initiating contact opens and after a programmable cooldown time has elapsed. The cooldown time can be programmed to give a 0 to 30 minute cooldown period before the engine shuts down.

In the MANUAL START position (6 o'clock), the engine will start and run as long as the ECS switch remains in this position.

In the STOP position (9 o'clock), the fuel solenoid shuts the engine down after a programmable cool down time period has elapsed.

In the OFF/RESET position (12 o'clock), the fault lights are reset and the engine shuts down immediately.

Caterpillar Monitoring System (13) – This system is the information center for the engine and related components. See the Operation Section, “Caterpillar Monitoring System” for more information.

Synchronization Mode Switch (14) – The synchronization mode switch (14) is manually operated. The switch has four positions: the AUTO position, the SEMI-AUTO position, the MANUAL (PERMISSIVE) position, and the OFF position. Refer to Illustration 36.

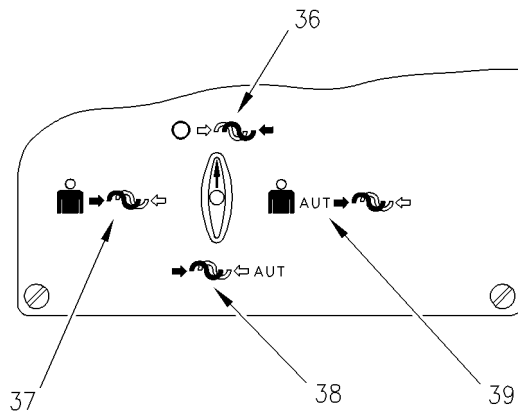

Illustration 36 g00692931
The Synchronization Mode Switch
(36) The OFF position
(37) The MANUAL (PERMISSIVE) position
(38) The AUTO position
(39) The SEMI-AUTO position

The AUTO position (6 o'clock) is used for complete automatic paralleling. The EMCP II+P brings the generator into sync with the bus and sends a signal to close the motor operated breaker. The EMCP II+P supports automatic paralleling to a dead bus. Automatic voltage matching is not provided.

When the synchronizer mode switch is in the SEMI-AUTO position (3 o'clock), the EMCP II+P brings the generator into sync with the bus and holds it there indefinitely. The operator brings the generator online by manually closing the breaker. Automatic voltage matching is not provided.

When the synchronizer mode switch is in the MANUAL (PERMISSIVE) position (9 o'clock), the operator adjusts the frequency and phase of the generator in order to match the bus. When the generator is in sync with the bus, the operator brings the generator online by manually closing the breaker.

When the synchronizer mode switch is in the OFF position (12 o'clock), all paralleling functions are disabled.

Breaker Open Pushbutton/Indicator (15) – When the generator is being taken off-line manually, the breaker open pushbutton must be pressed by the operator in order to open the breaker. When the breaker is open and the engine is running, the breaker open indicator (15) will light continuously.

Breaker Close Pushbutton/Indicator (16) – When the generator is being paralleled semi-automatically or manually, the breaker close pushbutton must be pressed by the operator in order to close the breaker. The system does not allow the breaker to close unless in sync. When the breaker is closed (generator is on line), the breaker close indicator (16) will light continuously.

Below, you can find the descriptions of the following main modules of the EMCP II+P:

- Generator Set Control + (GSC+)
- Alarm Module (ALM)
- Custom Alarm Module (CAM)

Generator Set Control + (GSC+)

Functions and Features of the GSC+

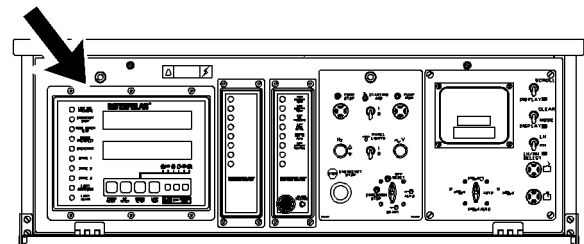

Illustration 37 g00634036
The Location of the GSC+ on the EMCP II+P Control Panel

The left side of the control panel contains the Generator Set Control + (GSC+). The GSC+ is the main component of the system. The GSC+ displays generator output, generator set functions, fault conditions, and key engine parameters. The GSC+ accepts information from the operator, magnetic pickup, oil pressure sensor, water temperature sensor, and optional remote sources. This information is used to determine the "ON/OFF" state of the engine's air, fuel, and starter.

In the very basic operating conditions, the GSC+ receives a signal to run the generator set. The GSC+ turns on the engine's fuel and starter. When the engine speed reaches the crank termination speed, the starter is disengaged. When the GSC+ receives a signal to stop the engine, the GSC+ shuts the fuel off.

The functions of the GSC+ are listed below.

- The GSC+ controls the normal starting and stopping of the engine.
- The GSC+ shows engine conditions and generator output information on two displays. The displays also show fault codes and GSC+ programming information.
- The GSC+ monitors the system for faults. If a fault occurs, the GSC+ performs a controlled fault shutdown or provides a fault alarm annunciation. The GSC+ uses indicators and displays in order to describe the fault.
- The GSC+ contains programmable features for certain applications or customer requirements.

The features of the GSC+ are listed below.

- **Cycle Crank:** The GSC+ can be programmed to crank for adjustable time periods. For programming instructions, refer to the Systems Operation, Testing and Adjusting, RENR2484, "Electronic Modular Control Panel II + (EMCP II+)".
- **Governor Control:** When the engine oil pressure increases past the low oil pressure set point, the GSC+ will indicate to the governor that the governor should increase the engine speed from idle RPM to rated RPM.
- **Cooldown:** Upon receiving a signal to perform a normal shutdown, the GSC+ will wait a preprogrammed amount of time before shutting the engine down by means of the fuel control.
- **Automatic Operation:** While in the automatic mode, the GSC+ can be started by a remote initiate signal (contact closure). Upon loss of the signal (contact opening), the GSC+ will perform a normal shutdown.
- **Alarm Module Communication:** The GSC+ can transmit fault and alarm conditions to an alarm module (AM).

- **Power Down:** The EMCP II+P system is designed to remove power from the GSC+ when the engine control switch (ECS) is in the OFF/RESET mode and when the proper jumper wire is removed. The GSC+ will not power down until the crank termination relay and the fuel control relay are both off for about 70 seconds. If the wire is not removed, the GSC+ will remain powered up. For the wiring diagram and the location of the jumper wire, refer to the Systems Operation, Testing and Adjusting, RENR2484, "Electronic Modular Control Panel II + (EMCP II+)".
- **Fuel Solenoid Type:** The GSC+ can be programmed to work with either an energized to run (ETR) fuel system or an energized to shutdown (ETS) fuel system.

Fault indicators

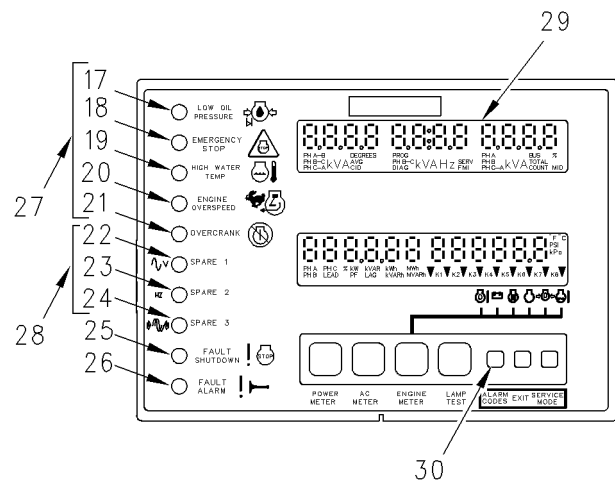

Illustration 38

g00634142

Display Area of the GSC+

- (17) Low oil pressure indicator
- (18) Emergency stop indicator
- (19) High water temperature indicator
- (20) Engine overspeed indicator
- (21) Overcrank indicator
- (22) Spare 1 indicator/Voltage match
- (23) Spare 2 indicator/Frequency match
- (24) Spare 3 indicator/Phasing match
- (25) Fault shutdown indicator
- (26) Fault alarm indicator
- (27) Dedicated shutdown indicators
- (28) Spare fault indicators
- (29) Upper display
- (30) The alarm codes key

The ten fault indicators are used in order to show and describe a fault that is present. The fault indicators are divided into four groups. The four groups are listed below.

- fault alarm indicator (26)

- fault shutdown indicator (25)
- spare fault indicators (28)
- dedicated shutdown indicators (27)

The yellow fault alarm indicator (26) FLASHES when the GSC+ detects an alarm fault. The alarm fault does not cause the engine status to change. The engine can be started. The engine will continue operating only if the engine is running at the time of the alarm fault. Fault alarm indicator (26) is accompanied by an alarm fault code that is shown on the upper display (29) when the alarm codes key (30) is pressed. For the descriptions of the fault codes, refer to the Systems Operation, Testing and Adjusting, RENR2484, “Electronic Modular Control Panel II + (EMCP II+)”.

The red fault shutdown indicator (25) FLASHES when the GSC+ detects a shutdown fault. The engine will shut down if the engine is running. The engine will not be allowed to start. Fault shutdown indicator (25) is accompanied by a fault code that is immediately shown on the upper display (29). For the descriptions of the fault codes, refer to the Systems Operation, Testing and Adjusting, RENR2484, “Electronic Modular Control Panel II + (EMCP II+)”.

The yellow spare fault indicators (28) can be used for paralleling as a redundant sync check. During the paralleling process and before the circuit breaker is closed, the lamps will indicate if the generator is in sync with the bus. The spare fault indicators are listed below.

- generator voltage match (spare 1 indicator)
- generator frequency match (spare 2 indicator)
- generator phasing match (spare 3 indicator)

If the generator parameters are not matched to the bus, the associated lamp will flash. When the generator and bus voltages, frequencies and phases are in sync, the lamps will light continuously.

When the control panel is not in a paralleling mode, the same three spare fault indicators (28) can be programmed by the customer. The three spare faults can be programmed to show coolant loss, oil temperature, spare fault condition or no assignment. The yellow spare fault indicators (28) FLASH when the conditions that are associated with that spare fault are active. The yellow fault alarm indicator (26) or the red fault shutdown indicator (25) will accompany the spare fault indicators (28). The spare fault indicators will tell whether the spare fault input is programmed to be an alarm condition or a shutdown condition. For the descriptions of the fault codes, refer to the Systems Operation, Testing and Adjusting, RENR2484, “Electronic Modular Control Panel II + (EMCP II+)”.

The red dedicated shutdown indicators (27) represent the following shutdown faults: low oil pressure, emergency stop, high water temperature, engine overspeed and engine overcrank. When the GSC+ detects a fault in one of these areas, the dedicated shutdown indicator (that corresponds to the fault) FLASHES. The engine is shutdown if the engine is running, and the engine is not allowed to start. No fault codes are associated with the dedicated shutdown indicators because each indicator has a descriptive label.

Many of the dedicated shutdown faults depend on certain setpoints in the GSC+. For the descriptions of the fault codes, refer to the Systems Operation, Testing and Adjusting, RENR2484, “Electronic Modular Control Panel II + (EMCP II+)”.

The conditions that are required to activate the dedicated fault shutdowns and the results of each dedicated fault are in the following list.

Low Oil Pressure – The engine oil pressure drops below the setpoints for low oil pressure shutdown that are programmed into the GSC+. There are two low oil pressure setpoints. One setpoint is used when the engine is at idle speed. The other setpoint is used when the engine is at rated speed. When a low oil pressure fault occurs, the low oil pressure indicator FLASHES, and the engine is shut down. The engine is not allowed to start until the fault is corrected.

Emergency Stop – The operator presses the Emergency Stop Push Button (ESPB) on the front panel. When an emergency stop condition occurs, the emergency stop indicator FLASHES and the engine is shut down. The engine is not allowed to start until the condition is corrected.

High Water Temperature – The engine coolant temperature rises above the setpoint for high water temperature shutdown that is programmed into the GSC+. When the high water temperature fault occurs, the high water temperature indicator FLASHES. The engine is shutdown and the engine is not allowed to start until the fault is corrected.

Engine Overspeed – The engine speed exceeds the setpoint for engine overspeed that is programmed into the GSC+. When the engine overspeed fault occurs, the engine overspeed indicator FLASHES. The engine is shutdown and the engine is not allowed to start until the fault is corrected.

Overcrank – The engine does not start within the setpoint for total cycle crank time that is programmed into the GSC+. When the overcrank fault occurs, the overcrank indicator FLASHES. The engine is not allowed to start until the fault is corrected.

Note: The GSC+ can be programmed to override the shutdown for low oil pressure and high water temperature faults. When the operator overrides the shutdown faults, the GSC+ responds to the faults as though the faults are alarm faults. The corresponding dedicated shutdown indicator is ON CONTINUOUSLY and will not be flashing. The engine continues to run and can be restarted when necessary. When the dedicated shutdown indicator is ON CONTINUOUSLY, the setpoint for shutdown has been exceeded, but the GSC+ is programmed to override the shutdown fault. The GSC+ does not treat the shutdown fault as a shutdown fault. The GSC+ treats the shutdown fault as an alarm fault. At the factory, the GSC+ is programmed to treat a low oil pressure fault and a high water temperature fault as shutdown faults. The operator or the service technician must decide to override these shutdown faults. The operator or the service technician must program the GSC+ to treat the shutdown faults as alarm faults. For programming procedures, refer to the Systems Operation, Testing and Adjusting, RENR2484, “Electronic Modular Control Panel II+ (EMCP II+)”.

Display

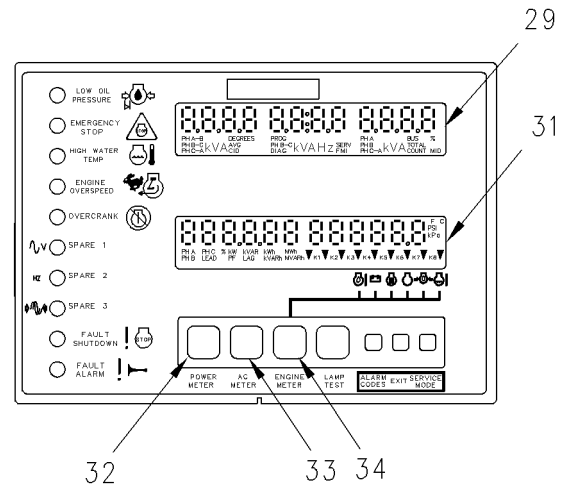

Illustration 39

g00634182

Display Area of the GSC+

- (29) Upper display
- (31) Lower display
- (32) The power meter key
- (33) The AC meter key
- (34) The engine meter key

The display consists of the upper display and the lower display. Both displays are used for programming functions when in service mode. For more information, see the Systems Operation, Testing and Adjusting, RENR2484, “Electronic Modular Control Panel II+ (EMCP II+)”.

Upper display

The EMCP II+P upper display (29) displays voltage and frequency. The voltage and frequency alternate between the generator output and the bus. The word “bus” or “gen” appears in the right side of the window. This word indicates which parameter is displayed.

Several options are available on the upper display for AC metering. These options can be viewed one at a time by pressing the AC meter key (33) on the keypad. The options are listed below.

- Average voltage, generator frequency, and total current
- Line to line voltage, generator frequency, and line current for any one phase
- Line to line voltage for all three phases at once
- Line current for all three phases at once

Note: When total current increases above “9999A”, the GSC+ will show current in “kA” units.

- Line to neutral voltage for all three phases at once

Upper display (29) is also used to show the various fault codes for system faults. For more information on fault codes, see the Systems Operation, Testing and Adjusting, RENR2484, “Electronic Modular Control Panel II+ (EMCP II+)”.

Note: Line to neutral voltages are not shown when the setpoint P032 is set to 1 for delta generator sets.

Lower display

The EMCP II+P lower display (31) displays the synchronoscope. This unique display allows a simultaneous visual indication of both frequency and phase of the generator set, in reference to the bus. Additionally, the three spare indicator lamps are used to indicate the synchronization status.

The lower display (31) shows values for power metering, engine parameters and the relay status.

The left side of the lower display (31) serves as a power meter for the generator set. The following functions will scroll automatically.

- Total real power (kW)
- Total reactive power (KVAR)
- Percentage of rated power (%kW)
- Power factor (average)
- Total energy output (kW/h)

The display will stop scrolling when the operator presses the power meter key for less than five seconds. The display will show a particular parameter continuously. Additional power meter functions will scroll if the power meter key (32) is held for more than five seconds and then released. The additional functions are shown below.

- Total real power (kW)
- Real power phase A (kW)
- Real power phase B (kW)
- Real power phase C (kW)
- Total apparent power (kVA)
- Total reactive power (KVAR)
- Percentage of rated power (%kW)

- Power factor (average)
- Power factor phase A
- Power factor phase B
- Power factor phase C
- Total energy output (kW/h)
- Total reactive energy output (KVARHr)

Note: All real power values are signed with a “+” or a “-”. A negative value indicates reverse power.

Note: Real power phase A, B, and C as well as power factor phase A, B, and C are not shown when setpoint P032 is set to 1 for delta generator sets.

Note: Total energy output that is greater than 999,999 kW/h will be shown as MW/h in two steps in order to maintain a resolution of 1 kW/h. The first step will show MW/h as a whole number up to six places. The second step will show MW/h as a decimal to three places. For example: 1,000,001 kW/h will be shown as 1000 MW/h (first step), followed by .001 MW/h (second step).

The right side of lower display (31) shows the value of certain engine parameters. The parameters are listed below.

- engine oil temperature (optional)
- system battery voltage
- engine hours
- engine speed
- engine oil pressure
- engine coolant temperature

The value for one of these conditions is shown on the display (31) for two seconds. The display then scrolls to the value for the next condition. A small pointer identifies the engine condition that corresponds to the value that is showing. When the engine meter key (34) is pressed, the lower display (31) stops scrolling. The lower display continuously shows one particular value. The pointer flashes above the value that is showing on the display. When the engine meter key (34) is pressed for the second time, the lower display will return to scrolling.

The relay status indicators are on the bottom of the lower display (31). When a GSC+ relay is activated, the corresponding indicator (K1, K2, etc) is shown on lower display (31). When a relay is not activated, the corresponding indicator (K1, K2, etc) is not shown. For a description of the relay functions, see the Systems Operation, Testing and Adjusting, RENR2484, "Electronic Modular Control Panel II+ (EMCP II+)".

Keypad

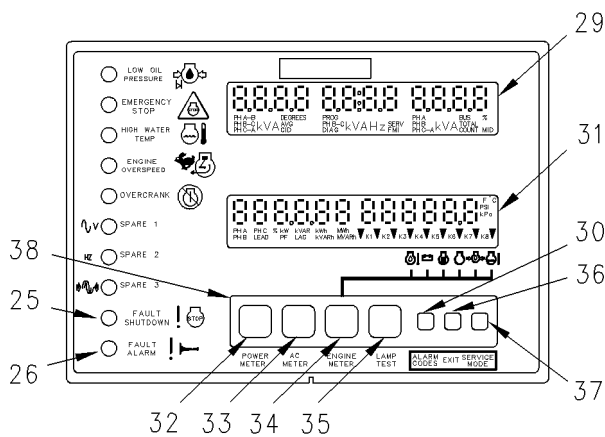

Illustration 40

g00634183

Keypad Area of the GSC+

- (25) Fault shutdown indicator
- (26) Fault alarm indicator
- (29) Upper display
- (30) Alarm codes key
- (31) Lower display
- (32) Power meter key
- (33) AC meter key
- (34) Engine meter key
- (35) Lamp test key
- (36) Exit key
- (37) Service mode key
- (38) Keypad

Keypad (38) is used to control the information that is shown on upper display (29) and lower display (31). The seven keys have two sets of functions: normal functions and service functions. For a description of the service functions of the keys, see the Systems Operation, Testing and Adjusting, RENR2484, "Electronic Modular Control Panel II+ (EMCP II+)". The normal functions of the keys are described in the following paragraphs.

Alarm Codes Key (30) – If fault alarm indicator (26) is FLASHING, pressing this key causes the upper display (29) to show the corresponding alarm fault code. If this key is pressed again, the generator AC output information will be shown on the upper display (29). If fault alarm indicator (26) is OFF, this key has no function.

Power Meter Key (32) – This key controls the viewing of power meter information. This information is shown on the lower display. Pressing the key for at least five seconds causes all the power meter data to scroll once. The default power meter data then resumes scrolling. If this key is pressed for less than five seconds, the display will stop scrolling the power meter functions until the key is pressed again.

AC Meter Key (33) – The AC meter key controls the viewing of the AC parameters on the upper display. Pressing the key causes the display to show a different set of parameters.

Engine Meter Key (34) – This key controls the viewing of engine parameters on the lower display. Pressing the key stops the scrolling of engine conditions. The value for one particular engine condition will show continuously. The pointer flashes indicating that the scrolling is stopped. The scrolling of the engine conditions will resume when the engine meter key is pressed again.

Lamp Test Key (35) – Pressing this key performs a lamp test on the GSC+ and the optional alarm module. On the GSC+, the ten fault indicators are ON CONTINUOUSLY. Every segment of upper display (5) and lower display (6) is ON. On the optional alarm module, all of the indicators are ON and the horn sounds. The lamp test function automatically turns off if an operator presses the key and holds the key for longer than ten seconds.

Exit Key (36) – This key only functions when the GSC+ is in Service Mode. For more information, see the Systems Operation, Testing and Adjusting, RENR2484, "Electronic Modular Control Panel II+ (EMCP II+)".

Service Mode Key (37) – Pressing this key causes the GSC+ to enter service mode. For more information, see the Systems Operation, Testing and Adjusting, RENR2484, "Electronic Modular Control Panel II+ (EMCP II+)".

Alarm Module

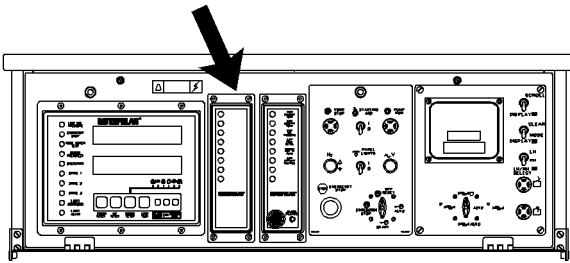

Illustration 41

g00635769

The Location of the Alarm Module (ALM) on the EMCP II+ Control Panel

The alarm module (ALM) is optional. The ALM is located in the center of the control panel. The function of the alarm module is to provide a visual and audible warning of engine conditions before these conditions become severe enough that the engine will shut down or will be unable to start.

One basic alarm module is used to satisfy the requirements for a standby NFPA 99 alarm module, standby NFPA 110 alarm module, NFPA 99 remote annunciator panel, and prime power alarm. This is accomplished by using different inputs to the module and different decals on the front of the module in order to indicate alarms or shutdown conditions. For all wiring and installation information, refer to the Systems Operation, Testing and Adjusting, RENR2484, "Electronic Modular Control Panel II+ (EMCP II+)". Refer to the above manual for a listing of indicators and alarm (horn) functions.

The front of the alarm module consists of the following indicators.

- Four amber indicators, which can (depending on module configuration) indicate High Coolant Temperature, Low Coolant Temperature or Low Coolant Level, Low Oil Pressure, Generator On Load, Charger Malfunction, Low Oil Level and Low Fuel Level
- Four red indicators, which can (depending on module configuration) indicate a Not In AUTO condition, Low DC Voltage, Air Damper Closed, Low Oil Pressure Shutdown, Overcrank Shutdown, High Coolant Temperature Shutdown, and Overspeed Shutdown
- An audible alarm and Acknowledge/Silence switch

For more detailed information, refer to the Systems Operation, Testing and Adjusting, RENR2484, "Electronic Modular Control Panel II+ (EMCP II+)".

Custom Alarm Module

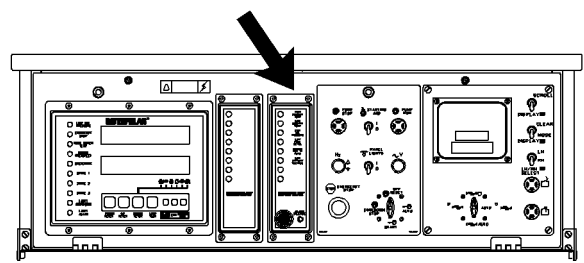

Illustration 42

g00635777

The Location of the Custom Alarm Module (CAM) on the EMCP II+ Control Panel

The Custom Alarm Module (CAM) is located in the center of the control panel. The function of the custom alarm module is to provide a visual and audible warning of the conditions of the customer supplied inputs before these conditions become severe enough that the engine will shut down or will be unable to start. The CAM has eight indicators, an audible horn, acknowledge/silence switch and the lamp test switch. Four of the indicator lamps are yellow. These yellow indicator lamps are used to indicate a fault shutdown. For all wiring and installation information, refer to the Systems Operation, Testing and Adjusting, RENR2484, "Electronic Modular Control Panel II+ (EMCP II+)". Refer to the above manual for the names of input signals.

Note: If an optional alarm module is ordered, the audible horn, acknowledge/silence switch and lamp test switch will come standard with the optional alarm module.

The front of the alarm module consists of the following indicators.

- Four amber indicators, which are used to display alarm conditions
- Four yellow indicators, which are used to display shutdown conditions

i02443021

Electronic Modular Control Panel 3 (EMCP 3)

SMCS Code: 4490

Electronic Control Module (Generator Set)

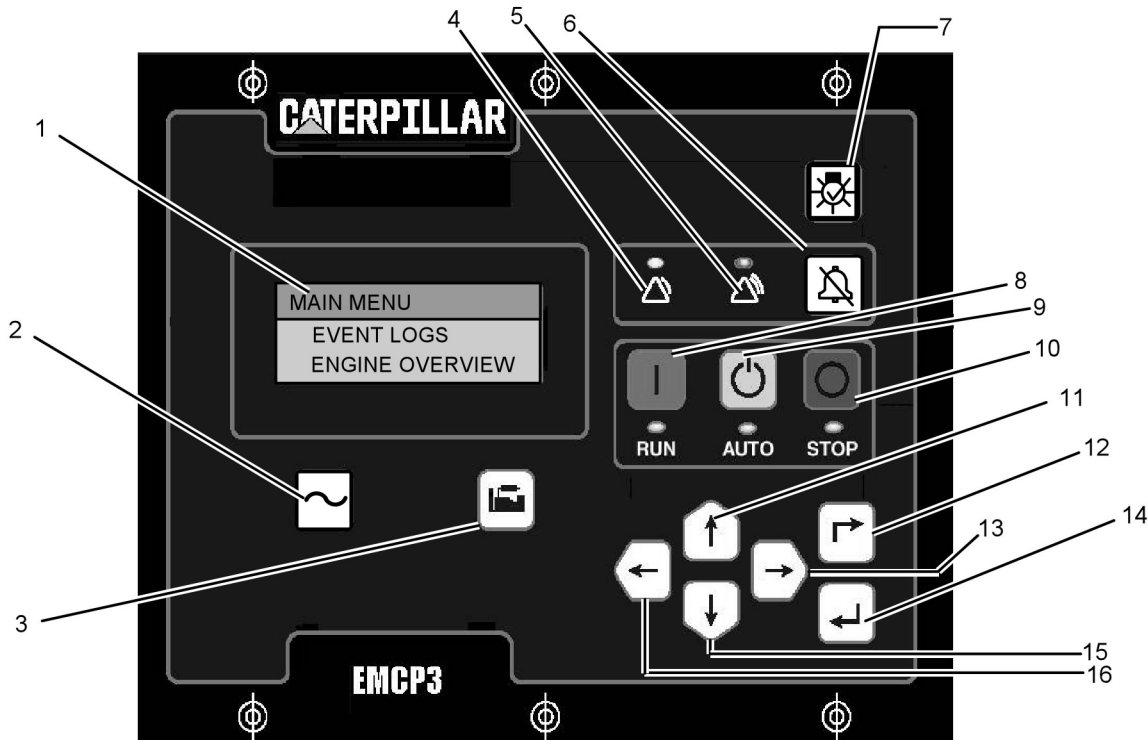

Illustration 43

g01045431

- (1) Display screen
- (2) AC overview key
- (3) Engine overview key
- (4) Yellow warning lamp
- (5) Red shutdown lamp
- (6) Alarm acknowledge key

- (7) Lamp test key
- (8) Run key
- (9) Auto key
- (10) Stop key
- (11) Up key
- (12) Escape key

- (13) Right key
- (14) Enter key
- (15) Down key
- (16) Left key

Navigation Keys

AC Overview (2) – The “AC OVERVIEW” key will navigate the display to the first screen of AC information. The “AC OVERVIEW” information contains various AC parameters that summarize the electrical operation of the generator set.

Engine Overview (3) – The “ENGINE OVERVIEW” key will navigate the display to the first screen of engine information. The “ENGINE OVERVIEW” information contains various engine parameters that summarize the operation of the generator set.

Acknowledge Key (6) – Pressing the “ACKNOWLEDGE” key will cause the horn relay to turn off. This will silence the horn. Pressing this key will also cause any red or yellow flashing lights to either turn off or to come on continuously, depending on the active status of the alarms. The “ACKNOWLEDGE” key may also be configured to send out a global alarm silence signal on the J1939 Data Link, which will silence the horns on the annunciators.

Lamp Test Key (7) – Pressing and holding the “LAMP TEST” key will cause each LED and the display screen pixels to turn on continuously until the key is released.

RUN Key (8) – Pressing the “RUN” key will start the engine.

AUTO Key (9) – Pressing the “AUTO” key will cause the engine to enter the “AUTO” mode. The engine will start if the module receives a start command from a remote source.

STOP Key (10) – Pressing the “STOP” key will stop the engine.

Up Key (11) – The “UP” key is used to navigate through the various menus and monitoring screens. The “UP” key is also used when a setpoint is entered. When entering numeric data, the “UP” key is used in order to increment the digits (0-9). If the setpoint requires selection from a list, the “UP” key is used to navigate UP through the list.

Escape Key (12) – The “ESCAPE” key is used in order to navigate through the menus. When the key is pressed, the user moves backward or the user moves upward through the menus. The “ESCAPE” key is also used to exit out of entering data when the user is programming the setpoints. If the “ESCAPE” key is pressed while the user is programming the setpoints, none of the changes made on the screen will be saved to memory.

Right Key (13) – The “RIGHT” key is used during setpoint adjustment. The “RIGHT” key is used to select which digit is edited while entering numeric data. The “RIGHT” key is also used during some setpoint adjustments in order to select or to unselect a check box. If a check box has a check mark, the function has been enabled. Pressing the “RIGHT” key will disable the function. Pressing the “RIGHT” key will also cause the check mark to disappear. If the check box does not have a check mark, the function is disabled. Pressing the “RIGHT” key will enable the function. Pressing the “RIGHT” key will also cause a check mark to appear.

Enter Key (14) – The “ENTER” key is used in order to navigate through the menus. When the key is pressed, the user moves forward or the user moves downward through the menus. The “ENTER” key is also used to save any changes while the setpoints are being programmed. Pressing the “ENTER” key during programming the setpoints causes the changes to be saved to memory.

Down Key (15) – The “DOWN” key is used to navigate downward through the various menus or screens. The “DOWN” key is also used to program the setpoints. The “DOWN” key is used to decrease the digits when entering numeric data. If the setpoint requires selection from a list, the “DOWN” key is used to navigate DOWN through the list.

Left Key (16) – The “LEFT” key is used during setpoint adjustment. The “LEFT” key is used to select the digit that is edited during the entry of numeric data. The “LEFT” key is also used during some of the setpoint adjustments to select a check box. The key is also used to unselect a check box. If a check box has a check mark, pressing the “LEFT” key will disable the function. Pressing the key will also remove the check mark. Pressing the “LEFT” key will also cause the check mark to disappear. If the check box does not have a check mark, pressing the “LEFT” key will enable the function. Pressing the “LEFT” key will also cause a check mark to appear.

Alarm Indicators

Yellow Warning Lamp (4) – A flashing yellow light indicates that there are active warnings that have not been acknowledged. A continuous yellow light indicates that there are acknowledged warnings that are active. If there are any active warnings, the yellow light will change from flashing yellow to continuous yellow after the “ACKNOWLEDGE” key is pressed. If there are no longer any active warnings, the yellow light will turn off after the “ACKNOWLEDGE” key is pressed.

Red Shutdown Lamp (5) – A flashing red light indicates that there are active shutdowns that have not been acknowledged. A continuous red light indicates that there are active shutdowns that have been acknowledged. If there are any active shutdowns the red light will change from flashing red to continuous red after the “ACKNOWLEDGE” key is pressed. Any condition that has caused a shutdown must be manually reset. If there are no longer any active shutdowns, the red light will turn off.

Digital Inputs

Note: There are 8 digital inputs on “EMCP 3.2” and “EMCP 3.3”. There are 6 digital inputs on “EMCP 3.1”.

Digital Input 1 – Digital Input 1 is used for the emergency stop. This input should be wired to GROUND through an Emergency Stop switch. The input can be set to activate on an active high (normally closed contact) or an active low (normally open contact). Activating the emergency stop input will cause the generator set to stop immediately. The emergency stop input will also prevent the generator set from starting. Once Digital Input 1 goes active the engine will not start until the event has been cleared. Refer to System Operation, Troubleshooting, Testing and Adjusting, RENR7902, “Digital Input Resetting”.

Digital Input 2 – Digital Input 2 is used for remotely starting and stopping the generator set. This input should be wired to GROUND through a switch that can be initiated remotely. The input can be set to activate on an active high (normally closed contact) or an active low (normally open contact). If the input is active and the engine is in AUTO, the engine will attempt to start. Once the input becomes inactive the engine will enter into cooldown mode (if programmed) and then the engine will stop.

The remainder of the inputs can be configured. The main purpose for the other “DIGITAL” inputs is to add additional monitoring capabilities of the parameters for the engine or generator. The inputs can be configured by going to the “EVENT I/P FUNCTIONS” parameter under the “SETPOINTS” menu. The “DIGITAL INPUTS” parameter can only be set to “ACTIVE HIGH” or “ACTIVE LOW” in order to initiate a High Warning, Low Warning, High Shutdown, Low Shutdown, or Status.

The inputs can be programmed to monitor the following parameters or components. Refer to System Operation, Troubleshooting, Testing and Adjusting, RENR7902, “Digital Input Programming”.

Pressures

- Air filter differential pressure
- Engine oil pressure
- Fire extinguisher pressure
- Fuel filter differential pressure
- Oil filter differential pressure
- Starting air pressure

Temperatures

- Ambient air temperature
- Engine coolant temperature
- Engine oil temperature
- Exhaust temperature
- Rear bearing temperature (C32 only)
- Right exhaust temperature
- Left exhaust temperature

Levels

- Engine coolant level

- Engine oil level
- Fuel level
- External fuel tank level

Other

- Air damper closed
- ATS in normal position
- ATS in emergency position
- Battery charger failure
- Generator breaker closed
- Utility breaker closed
- Fuel leak detected
- Custom event

For detailed information about the electronic control module, see Systems Operation, Troubleshooting, Testing and Adjusting, RENR7902, “EMCP3”.

Control Panel

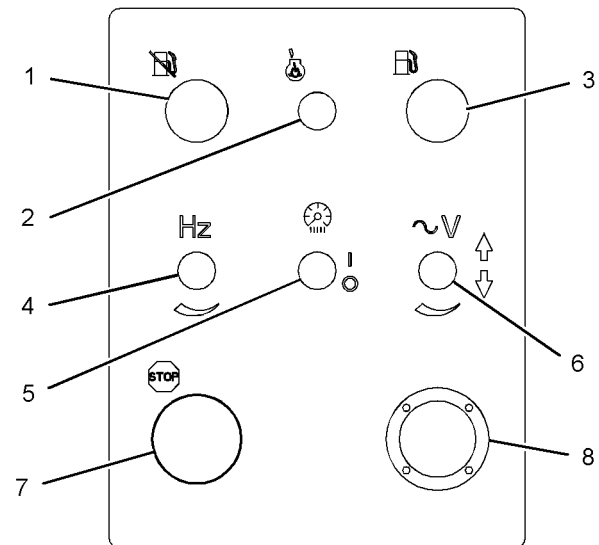

Illustration 44

g01220625

C27

- (1) Pump stop switch
- (2) Starting aid auto/manual switch (optional)
- (3) Pump run switch
- (4) Speed potentiometer (optional)
- (5) Panel light switch
- (6) Voltage adjust switch
- (7) Emergency stop push button
- (8) Diagnostic connector

Note: Your application may not have all of these features.

Pump Stop Switch (1) – The pump stop switch is optional. The pump stop switch is used to manually stop the fuel transfer pump. Fully depress the switch in order to latch the switch. The red indicator will now be ON. The switch can be reset by pressing the switch again. The red indicator will now be OFF.

Starting Aid Auto/Manual Switch (2) – The starting aid switch is optional. The starting aid switch is used to inject ether into the engine when you are starting the engine in cold weather conditions. When the starting aid switch is in the ON position, the switch energizes the starting aid solenoid valve and the switch meters a specific amount of ether into a holding chamber. When the starting aid switch is released, the solenoid releases the ether to the engine.

Pump Run Switch (3) – The pump run switch is optional. Pushing this switch will cause the generator set that is mounted on the fuel transfer pump to fill the generator set day tank. The green indicator will be on when the pump is running. The pump will automatically shut off when the fuel reaches the high fuel level. The pump can also be turned to the OFF position manually by the pump stop switch (1). The pump stop switch must be reset. Reset the pump stop switch by pressing the switch again.

Speed Potentiometer (4) – The speed potentiometer is optional. The speed potentiometer can be used with the generator set that has an electronic governor.

Panel Light Switch (5) – The panel lights switch turns on or the panel lights switch turns off the panel lights.

Voltage Adjust Switch (6) – This switch can be used to raise the voltage. The switch can also be used to lower the voltage.

Emergency Stop Push Button (7) – The emergency stop push button (ESPB) is used to shut down the engine during an emergency situation. If equipped, the ESPB shuts off the fuel and the ESPB activates the optional air shutoff.

Diagnostic Connector(8) – The Electronic Technician (ET) is used to communicate to the electronic control module over the data link by connecting to the diagnostic connector.

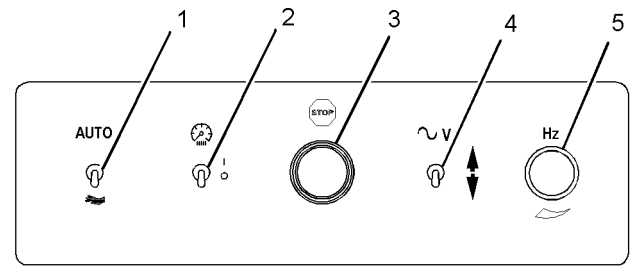

Illustration 45

g01155394

C32

- (1) Starting aid auto/manual switch (optional)
- (2) Panel light switch
- (3) Emergency stop push button
- (4) Voltage adjust switch
- (5) Speed potentiometer (optional)

Note: Your application may not have all of these features.

Starting Aid Auto/Manual Switch (1) – The starting aid switch is optional. The starting aid switch is used to inject ether into the engine when you are starting the engine in cold weather conditions. When the starting aid switch is in the ON position, the switch energizes the starting aid solenoid valve and the switch meters a specific amount of ether into a holding chamber. When the starting aid switch is released, the solenoid releases the ether to the engine.

Panel Light Switch (2) – The panel lights switch turns on or the panel lights switch turns off the panel lights.

Emergency Stop Push Button (3) – The emergency stop push button (ESPB) is used to shut down the engine during an emergency situation. If equipped, the ESPB shuts off the fuel and the ESPB activates the optional air shutoff.

Voltage Adjust Switch (4) – This switch can be used to raise the voltage. The switch can also be used to lower the voltage.

Speed Potentiometer (5) – The speed potentiometer is optional. The speed potentiometer can be used with the generator set that has an electronic governor.

Annunciator Module

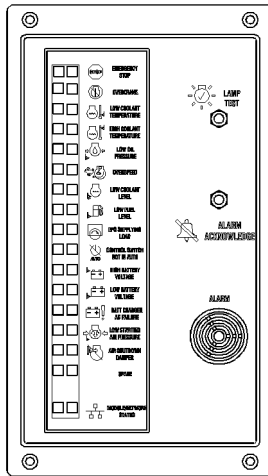

Illustration 46

g01101388

General Information

The annunciator module is used to indicate various system events and conditions. The annunciator module uses indicator lights and an audible horn to give the operator information about the current status of the system. The annunciator module can be used to announce faults and/or status signals to the operator. The annunciator module allows the operator to silence the horn. The annunciator module also allows the operator to acknowledge faults to the system.

There are seventeen pair of LED indicators on the annunciator's front panel. Sixteen pair of LED indicators are used to announce events, diagnostics, and ready signals. The seventeenth pair of LED indicators is used as a combined network/module status LED. The seventeenth pair of LED indicators can tell the operator if there is a problem with the J1939 data link connection.

Basic Operation

Each pair of LED indicators on the annunciator consists of two of the following three colors: green, yellow, and red. For example, a pair of red and yellow LED indicators may be configured for engine oil pressure. If a low engine oil pressure warning is read over the data link, the annunciator will flash the yellow LED and the audible horn will sound. If the low engine oil pressure shutdown is read over the data link, the annunciator will flash the red LED and the audible horn will sound.

To acknowledge the shutdown and alarm conditions or to silence the horn, press the "Alarm Acknowledge" button that is located near the middle of the annunciator.

To test the LED indicators or to test the horn when the data link is connected or the data link is disconnected, hold in the "Lamp Test" button that is located near the top of the annunciator.

Configuration

The annunciator module can be customized in order to signal many different conditions that are related to the system. Each pair of LEDs must be configured by using the appropriate service tool. Once the service tool has been connected to the annunciator, the user must enter the "Configuration" screen. Each pair of LEDs has four settings: SPN, Trigger Type, Trigger Severity Level, and Failure Mode Identifier (FMI).

For detailed information about the annunciator module, see Systems Operation, Troubleshooting, Testing and Adjusting, RENR7902, "EMCP3".

Engine Starting

i02048636

Before Starting Engine

SMCS Code: 1000; 1400; 1450

Perform the required daily maintenance and other periodic maintenance before the engine is started. Inspect the engine compartment. This inspection can help prevent major repairs at a later date. Refer to the Operation and Maintenance Manual, "Maintenance Interval Schedule" for more information.

- For the maximum service life of the engine, make a thorough inspection before the engine is started. Look for the following items: oil leaks, coolant leaks, loose bolts, and trash buildup. Remove trash buildup and arrange for repairs, as needed.
- Inspect the cooling system hoses for cracks and for loose clamps.
- Inspect the alternator and accessory drive belts for cracks, breaks, and other damage.
- Inspect the wiring for loose connections and for worn wires or frayed wires.
- Check the fuel supply. Drain water from the water separator (if equipped). Open the fuel supply valve.

NOTICE

All valves in the fuel return line must be open before and during engine operation to help prevent high fuel pressure. High fuel pressure may cause filter housing failure or other damage.

If the engine has not been started for several weeks, fuel may have drained from the fuel system. Air may have entered the filter housing. Also, when fuel filters have been changed, some air pockets will be trapped in the engine. In these instances, prime the fuel system. Refer to the Operation and Maintenance Manual, "Fuel System - Prime" for more information on priming the fuel system.

WARNING

Engine exhaust contains products of combustion which may be harmful to your health. Always start and operate the engine in a well ventilated area and, if in an enclosed area, vent the exhaust to the outside.

- Do not start the engine or move any of the controls if there is a "DO NOT OPERATE" warning tag or similar warning tag attached to the start switch or to the controls.
- Ensure that the areas around the rotating parts are clear.
- All of the guards must be put in place. Check for damaged guards or for missing guards. Repair any damaged guards. Replace damaged guards and/or missing guards.
- Disconnect any battery chargers that are not protected against the high current drain that may be created. Check electrical cables and check the battery for poor connections and for corrosion.
- Reset all of the shutoffs or alarm components.
- Check the engine lubrication oil level. Maintain the oil level between the "ADD" mark and the "FULL" mark on the oil level gauge.
- Check the coolant level. Observe the coolant level in the coolant recovery tank (if equipped). Maintain the coolant level to the "FULL" mark on the coolant recovery tank.
- If the engine is not equipped with a coolant recovery tank maintain the coolant level within 13 mm (0.5 inch) of the bottom of the filler pipe. If the engine is equipped with a sight glass, maintain the coolant level in the sight glass.
- Observe the air cleaner service indicator (if equipped). Service the air cleaner when the yellow diaphragm enters the red zone, or when the red piston locks in the visible position.
- Ensure that any driven equipment has been disengaged. Minimize electrical loads or remove any electrical loads.

i02385404

Cold Weather Starting

SMCS Code: 1000; 1250; 1450; 1453; 1456; 1900

WARNING

DO NOT USE ETHER (starting fluids) unless specifically instructed to do so. If the engine is equipped with an Air Inlet Heater (electrically or fuel ignited manifold heater), DO NOT use ether (starting fluids) at any time. The use could result in engine damage and/or personal injury.

Startability will be improved at temperatures below 10°C (50°F) from the use of a cylinder block coolant heater or from other means that are used to heat the crankcase oil. Some engine applications use a jacket water heater to improve startability. This will help reduce white smoke and misfire during start-up in cold weather.

NOTICE

When using ether (starting fluid), follow the manufacturer's instructions carefully, use it sparingly and spray it only while cranking the engine. Excessive ether can cause piston and ring damage. Use ether (starting fluid) for cold weather starting purposes only.

For engines that are not equipped with an Air Inlet Heater, use ether when temperatures are below 0°C (32°F). If the engine is equipped with an injection system for starting fluid, crank the engine. Depress the ether switch for three seconds. Additional injections may be necessary in order to start the engine.

Note: If the engine has not been run for several weeks, fuel may have drained. Air may have moved into the filter housing. Also, when fuel filters have been changed, some air will be left in the filter housing. Refer to the Operation and Maintenance Manual, "Fuel System - Prime" (Maintenance Section) for more information on priming the fuel system.

NOTICE

Do not engage the starting motor when flywheel is turning. Do not start the engine under load.

If the engine fails to start within 30 seconds, release the starter switch or button and wait two minutes to allow the starting motor to cool before attempting to start the engine again.

1. Ensure that the quick disconnect switch is in the ON position.
2. Push the start button in order to crank the engine.

Do not push down or hold the throttle down while the engine is cranked. The system will automatically provide the correct amount of fuel that is needed to start the engine.

3. If the engine fails to start within 30 seconds, release the start button, or the ignition switch. Wait for two minutes in order to allow the starting motor to cool before attempting to start the engine again.

NOTICE

Oil pressure should rise within 15 seconds after the engine starts. Do not increase engine speed until the oil pressure gauge indicates normal. If oil pressure is not indicated on the gauge within 15 seconds, DO NOT operate the engine. STOP the engine, investigate and correct the cause.

4. Allow the engine to idle for approximately three minutes. Idle the engine until the water temperature gauge has begun to rise. Check all gauges during the warm-up period.

Note: The oil pressures and fuel pressures should be in the normal range on the instrument panel. Do not apply a load to the engine or increase engine rpm until the oil pressure gauge indicates at least normal pressure. Inspect the engine for leaks and/or unusual noises.

i02422473

Starting the Engine (EMCP 3)

SMCS Code: 1000; 1450

1. Start the engine by one of these three methods.
 - The operator presses the "RUN" Key.
 - The control is in "AUTO" and the remote initiate contact (IC) becomes active.
 - The operator presses the "AUTO" Key and a start command is sent via the RS-485 SCADA Data Link.
2. The EMCP 3 checks the system before the crank cycle begins. The EMCP 3 checks that no system faults are present. The EMCP 3 checks that all previous shutdown faults have been reset. The EMCP 3 also checks that the engine is not already running. If the engine is equipped with prelube, the EMCP 3 checks the status of the prelube. If the prelube is not complete, the EMCP 3 will not crank the engine.
3. The EMCP 3 begins the crank cycle.
4. The EMCP 3 cranks the engine until the crank cycle time reaches the setpoint for total crank time or until the engine starts.
5. The EMCP 3 deactivates the starting motor relay (SMR) when the engine speed reaches the setpoint for crank terminate speed.

i01934760

Starting with Jump Start Cables

SMCS Code: 1000; 1401; 1402; 1900

WARNING

Improper jump start cable connections can cause an explosion resulting in personal injury.

Prevent sparks near the batteries. Sparks could cause vapors to explode. Do not allow jump start cable ends to contact each other or the engine.

If the installation is not equipped with a backup battery system, it may be necessary to start the engine from an external electrical source.

NOTICE

Using a battery source with the same voltage as the electric starting motor. Use **ONLY** equal voltage for jump starting. The use of higher voltage will damage the electrical system.

Do not reverse the battery cables. The alternator can be damaged. Attach ground cable last and remove first.

When using an external electrical source to start the engine, turn the generator set control switch to the "OFF" position. Turn all electrical accessories OFF before attaching the jump start cables.

Ensure that the main power switch is in the OFF position before attaching the jump start cables to the engine being started.

1. Turn the start switch to the OFF position. Turn off all accessories.
2. Connect one positive end of the jump start cable to the positive cable terminal of the discharged battery. Connect the other positive end of the jump start cable to the positive cable terminal of the electrical source.
3. Connect one negative end of the jump start cable to the negative cable terminal of the electrical source. Connect the other negative end of the jump start cable to the engine block or to the chassis ground. This procedure helps to prevent potential sparks from igniting combustible gases that are produced by some batteries.
4. Start the engine.

5. Immediately after the stalled engine is started, disconnect the jump start cables in reverse order.

Note: If there is a problem with the alternator or the battery charger, the engine will not continue to run after starting, unless the power to the engine control module is supplied by a separate source.

i01646248

After Starting Engine

SMCS Code: 1000

Note: In temperatures from 0 to 60°C (32 to 140°F), the warm-up time is approximately three minutes. In temperatures below 0°C (32°F), additional warm-up time may be required.

Note: Ensure that the self test for the monitoring system (if equipped) is completed before operating the engine under load.

When the engine idles during warm-up, observe the following conditions:

- Check for any fluid or for any air leaks at idle rpm and at one-half full rpm (no load on the engine) before operating the engine under load. This is not possible in some applications.
- Operate the engine at low idle until all systems achieve operating temperatures. Check all gauges during the warm-up period.

Note: Gauge readings should be observed and the data should be recorded frequently while the engine is operating. Comparing the data over time will help to determine normal readings for each gauge. Comparing data over time will also help detect abnormal operating developments. Significant changes in the readings should be investigated.

Engine Operation

i01136207

Engine Operation

i01646252

SMCS Code: 1000

Proper operation and maintenance are key factors in obtaining the maximum life and economy of the engine. If the directions in the Operation and Maintenance Manual are followed, costs can be minimized and engine service life can be maximized.

The time that is needed for the engine to reach normal operating temperature can be less than the time taken for a walk-around inspection of the engine.

The engine can be operated at the rated rpm after the engine is started and after the engine reaches operating temperature. The engine will reach normal operating temperature sooner during a low engine speed (rpm) and during a low power demand. This procedure is more effective than idling the engine at no load. The engine should reach operating temperature in a few minutes.

Gauge readings should be observed and the data should be recorded frequently while the engine is operating. Comparing the data over time will help to determine normal readings for each gauge. Comparing data over time will also help detect abnormal operating developments. Significant changes in the readings should be investigated.

Fuel Conservation Practices

SMCS Code: 1000; 1250

The efficiency of the engine can affect the fuel economy. Caterpillar's design and technology in manufacturing provides maximum fuel efficiency in all applications. Follow the recommended procedures in order to attain optimum performance for the life of the engine.

- Avoid spilling fuel.

Fuel expands when the fuel is warmed up. The fuel may overflow from the fuel tank. Inspect fuel lines for leaks. Repair the fuel lines, as needed.

- Be aware of the properties of the different fuels. Use only the recommended fuels.
- Avoid unnecessary idling.

Shut off the engine rather than idle for long periods of time.

- Observe the service indicator frequently. Keep the air cleaner elements clean.
- Ensure that the turbochargers are operating correctly so that the proper air/fuel ratio is maintained. Clean exhaust indicates proper functioning.
- Maintain a good electrical system.

One faulty battery cell will overwork the alternator. This will consume excess power and excess fuel.

- Ensure that the belts are properly adjusted. The belts should be in good condition.
- Ensure that all of the connections of the hoses are tight. The connections should not leak.
- Ensure that the driven equipment is in good working order.
- Cold engines consume excess fuel. Utilize heat from the jacket water system and the exhaust system, when possible. Keep cooling system components clean and keep cooling system components in good repair. Never operate the engine without water temperature regulators. All of these items will help maintain operating temperatures.

Engine Stopping

i02443872

Emergency Stopping

i02237582

SMCS Code: 1000; 7418

NOTICE

Emergency shutoff controls are for EMERGENCY use ONLY. DO NOT use emergency shutoff devices or controls for normal stopping procedure.

Ensure that any components for the external system that support the engine operation are secured after the engine is stopped.

NOTICE

Do not start the engine until the problem necessitating the emergency stop has been located and corrected.

Emergency Stop Button

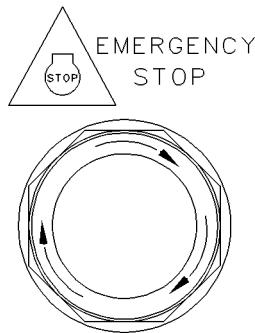

Illustration 47

g00104303

Typical emergency stop button

The emergency stop button is in the OUT position for normal engine operation. Push the emergency stop button. The engine will not start when the button is locked. Turn the button clockwise in order to reset.

Manual Stop Procedure

SMCS Code: 1000; 7418

Note: Individual applications will have different control systems. Ensure that the shutoff procedures are understood. Use the following general guidelines in order to stop the engine.

1. Remove the load, when possible. Reduce the engine speed (rpm) to idle.
2. Press the "STOP" button on the control panel. The controller has a programmed 5 minute cooldown.

i02885872

After Stopping Engine

SMCS Code: 1000

- Check the engine crankcase oil level. Maintain the oil level between the "ADD" and "FULL" marks on the "ENGINE STOPPED" side of the oil level gauge.
- If necessary, perform minor adjustments. Repair any leaks and tighten loose bolts.
- Note the service hour meter reading. Perform the maintenance that is scheduled in this Operation and Maintenance Manual, "Maintenance Interval Schedule" (Maintenance Section).

NOTICE

Follow the guidelines for antifreeze/coolant mixtures that are recommended in this Operation and Maintenance Manual, "Refill Capacities and Recommendations" topic. Failure to do so can cause engine damage.

- Allow the engine to cool. Check the coolant level.
- Loosen the cooling system filler cap slowly in order to relieve any pressure. Remove the cooling system filler cap.
- If freezing temperatures are expected, check the coolant for protection against freezing. The cooling system must be protected against freezing to the lowest expected outside temperature. Add the proper coolant/water mixture, if necessary.
- Perform all required periodic maintenance on all driven equipment. Refer to the instructions that are provided by the OEM of the driven equipment.

Cold Weather Operation

i02237624

Fuel and the Effect from Cold Weather

SMCS Code: 1000; 1250; 1280

The following fuels are the grades that are available for Caterpillar engines:

- No. 1
- No. 2
- Blend of No. 1 and No. 2

No. 2 diesel fuel is the most commonly used fuel. Either No. 1 diesel fuel or a blend of No. 1 and No. 2 is best suited for cold weather operation.

Quantities of No. 1 diesel fuel are limited. No. 1 diesel fuels are usually available during the months of the winter in the colder climates. During cold weather operation, if No. 1 diesel fuel is not available, use No. 2 diesel fuel, if necessary.

There are three major differences between No. 1 and No. 2 diesel fuel. No. 1 diesel fuel has the following properties:

- Lower cloud point
- Lower pour point
- Lower rating of kJ (BTU) per unit volume of fuel

When No. 1 diesel fuel is used, a decrease in power and in fuel efficiency may be noticed. Other operating effects should not be experienced.

The cloud point is the temperature when a cloud of wax crystals begins to form in the fuel. These crystals can cause the fuel filters to plug. The pour point is the temperature when diesel fuel will thicken. The diesel fuel becomes more resistant to flow through fuel pumps and through fuel lines.

Be aware of these values when diesel fuel is purchased. Anticipate the average ambient temperature of the area. Engines that are fueled in one climate may not operate well if the engines are moved to another climate. Problems can result due to changes in temperature.

Before troubleshooting for low power or for poor performance in the winter, check the type of fuel that is being used.

When No. 2 diesel fuel is used the following components provide a means of minimizing problems in cold weather:

- Starting aids
- Engine oil pan heaters
- Engine coolant heaters
- Fuel heaters
- Fuel line insulation

For more information on cold weather operation, see Special Publication, SEBU5898, "Cold Weather Recommendations".

i02225022

Fuel Related Components in Cold Weather

SMCS Code: 1000; 1250; 1280

Fuel Tanks

Condensation can form in partially filled fuel tanks. Top off the fuel tanks after operating the engine.

Fuel tanks should contain some provision for draining water and sediment from the bottom of the tanks. Some fuel tanks use supply pipes that allow water and sediment to settle below the end of the fuel supply pipe.

Some fuel tanks use supply lines that take fuel directly from the bottom of the tank. If the engine is equipped with this system, regular maintenance of the fuel system filter is important.

Drain the water and sediment from any fuel storage tank at the following intervals:

- Weekly
- Oil changes
- Refueling of the fuel tank

This will help prevent water and/or sediment from being pumped from the fuel storage tank and into the engine fuel tank.

Fuel Filters

NOTICE

Do not fill the fuel filters with fuel before installing them. The fuel would not be filtered and could be contaminated. Contaminated fuel will cause accelerated wear to fuel system parts.

NOTICE

In order to maximize fuel system life and prevent premature wear out from abrasive particles in the fuel, a two micron absolute high efficiency fuel filter is required for all Caterpillar Hydraulic Electronic Unit Injectors. Caterpillar High Efficiency Fuel Filters meet these requirements. Consult your Caterpillar dealer for the proper part numbers.

These engines are equipped with a primary filter/water separator. The primary filter/water separator must use a 10 micron filter to a 15 micron filter. The filters are becoming more critical as fuel injection pressures increase to 209 MPa (30000 psi) and higher psi. For more information on priming the fuel system, see the Operation and Maintenance Manual, "Fuel System - Prime" topic (Maintenance Section).

Fuel Heaters

Note: Always follow the precautions in this Operation and Maintenance Manual, "Fire Prevention and Explosion Prevention".

Fuel heaters help to prevent fuel filters from plugging in cold weather due to waxing. A fuel heater should be installed in order for the fuel to be heated before the fuel enters the primary fuel filter.

Select a fuel heater that is mechanically simple, yet adequate for the application. The fuel heater should also help to prevent overheating of the fuel. High fuel temperatures reduce engine performance and the availability of engine power. Choose a fuel heater with a large heating surface. The fuel heater should be practical in size. Small heaters can be too hot due to the limited surface area.

Disconnect the fuel heater in warm weather.

Note: Fuel heaters that are controlled by the water temperature regulator or self-regulating fuel heaters should be used with this engine. Fuel heaters that are not controlled by the water temperature regulator can heat the fuel in excess of 65° C (149° F). A loss of engine power can occur if the fuel supply temperature exceeds 37° C (100° F).

Note: Heat exchanger type fuel heaters should have a bypass provision in order to prevent overheating of the fuel in warm weather operation.

For further information on fuel heaters, consult your Caterpillar dealer.

Generator Operation

i02443880

Generator Operation

SMCS Code: 4450

Loading of the Generator

When a generator is installed or reconnected, be sure that the total current in one phase does not exceed the nameplate rating. Each phase should carry the same load. This allows the engine to work at the rated capacity. If one phase current exceeds the nameplate amperage, an electrical unbalance can result in an electrical overload and overheating .

Allowable combinations of unbalanced loads are shown in Illustration 48. When you operate with significant single-phase loads, the combinations of single-phase load and three-phase load may be used. Such combinations should be located below the line on the graph.

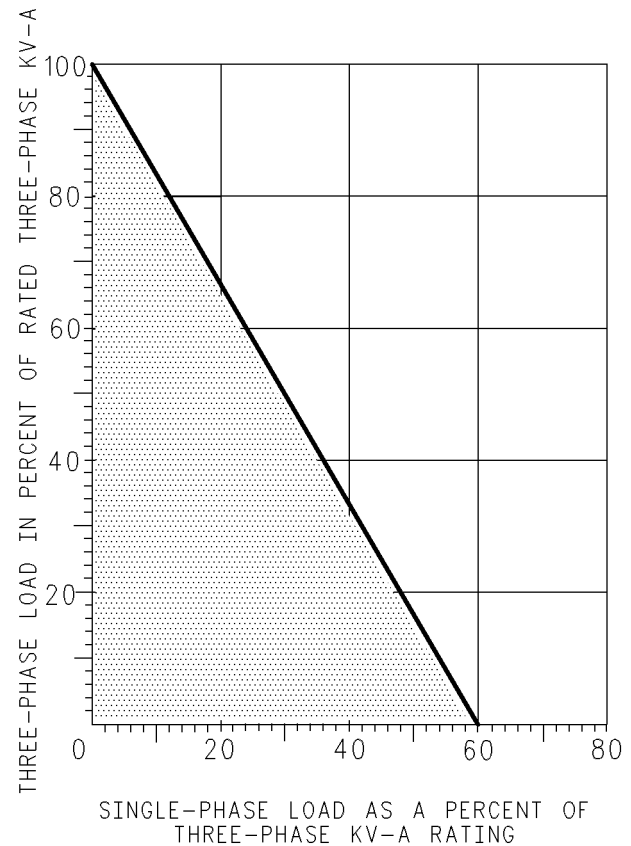

Illustration 48

g00627416

Allowable Combinations of Unbalanced Loads

Block Loading

Block loading is the instantaneous application of an electrical load to a generator set. This load may be anywhere from a moderate percentage of the rated load up to the rated load.

The block loading capability of a generator set depends on the following factors.

- Engine transient response
- Voltage regulator response
- Type of the voltage regulator
- Altitude of operation of the generator set
- Type of load
- Percent of load before the block load is applied

If derating for the block load is required, refer to ISO 3046 Standards or SAE J1349 Standards. Also, reference Engine Data Sheet, LEKX4066, "Loading Transient Response" and Engine Data Sheet, LEKX4067, "Block and Transient Response".

Note: ISO stands for International Standards Organization.

Power Factor

The power factor represents the efficiency of the load. Power factor is the ratio of apparent power to total power. The power factor is expressed as a decimal. The power factor represents that portion of the current which is doing useful work. The portion of current which is not doing useful work is absorbed in maintaining the magnetic field in motors or other devices.

In most applications, electric motors and transformers determine the power factor of the system. Induction motors usually have a 0.8 or smaller power factor. Incandescent lighting is a resistive load of about 1.0 power factor, or unity.

The power factor of a system may be determined by a power factor meter or by calculations. Determine the power requirement in kW by multiplying the power factor by the kVA that is supplied to the system. As the power factor increases, the total current supplied to a constant power demand will decrease. For example, a 100 kW load at a 0.8 power factor will draw more current than a 100 kW load at 0.9 power factor. High power factor will result in full engine load at less than the rated amperage of the generator. A lower power factor increases the possibility of overloading the generator.

Note: Caterpillar generators are designed for a 0.8 power factor unless otherwise specified.

Excitation Systems

Self-Excited Generators

Self-excited (SE) generators receive power for excitation and voltage sensing for the regulator from the output of the main armature of the generator. The voltage regulator senses the generator output voltage. The voltage regulator provides the regulated output to the exciter of the generator. The exciter then provides power to the main rotating field. As the main field rotates, a voltage is induced into the main armature. This voltage is a generator output voltage.

Note: The main armature is also called the stator. The main rotating field is also called the rotor.

Permanent Magnet Pilot Excited Generators

Permanent Magnet Pilot Excited (PMPE) generators receive power for the voltage regulator from a pilot exciter, rather than the main armature. The pilot exciter consists of a permanent magnet rotor and a permanent magnet stator. The pilot exciter operates independently from the generator output voltage. Constant excitation during a large load application is possible because the irregularities that occur in generator output voltage are not fed back into the exciter. Such irregularities can be caused by load conditions. The independent operation also allows the generator to better sustain an overload for a short duration. The pilot exciter also ensures that the generator will start properly even if the rotating field becomes completely demagnetized.

Low Idle Adjustment

Generator sets normally have a higher low idle setting than industrial engines. Low idle will be approximately 66% of the full load speed of 60 Hz units. Low idle will be approximately 80% of the full load speed of 50 Hz units.

There is no low idle stop on generator sets with electronic governors. On generator sets with mechanical governors and natural gas generator sets, the low idle is set at the factory. The low idle should only be adjusted by your Caterpillar dealer if adjustment is required.

Note: Operating the generator set at low idle speed for an extended time will cause some voltage regulators to shut off. The generator set must be completely shut down. Then, the generator set must be restarted. This will allow the voltage regulator to again produce an output.

Standby Generator Sets

Most standby units are installed with controls that will start the unit automatically. Standby units start, pick up the load, run, and stop without an operator in attendance.

Standby units can not change the governor (speed) control, or change the voltage level settings automatically. The governor speed and voltage level must be preset for the proper operation of the standby unit. Whenever the set is operated manually, be sure that the governor speed and voltage levels are correct for automatic operation. Check all switches for the proper setting. The start select switch should be in the AUTOMATIC position. Emergency Stop Switches should be in RUN position.

Generator Options

Space Heaters

Most of the SR4B generators are provided with space heaters. These space heaters are installed for operation in high humidity conditions. For more information on space heaters, refer to Maintenance Section, "Space Heater - Check".

Embedded Temperature Detectors

SR4B generators are available with embedded temperature detectors. The detectors are installed in the slots of the main armature. The main armature is also called a stator. The detectors are used with the equipment that is provided by the customer. Thus, the temperature of the main armature winding can be measured or monitored. Three types of temperature detectors are available. Contact your Caterpillar dealer for more information.

Bearing Temperature Detectors

Bearing temperature detectors are available as an option on SR4B generators. Bearing temperature detectors measure main bearing temperature. Bearing temperature detectors are used with the equipment that is provided by the customer. Thus, the temperature of the bearing can be measured or monitored. Bearing temperature measurements may help to prevent premature bearing failure. Two types of temperature detectors are available. Contact your Caterpillar dealer for more information.

i02324949

Parallel Operation

SMCS Code: 4450

Initial Start-Up

Preparing a generator for parallel operation requires special attention. Before you attempt to parallel units for the first time, check all the units for the following three conditions.

- same phase rotation
- same alternating current frequency
- same voltage adjustment

1. Check the phase rotation.

Units that operate in parallel must have the same phase rotation. There are two methods that may be used in order to determine if the incoming unit and the unit that is on-line have the same phase rotation. These methods are listed below:

- using a phase rotation meter
- using a set of three light bulbs

Use the procedure below to determine the proper phase rotation by using three light bulbs.

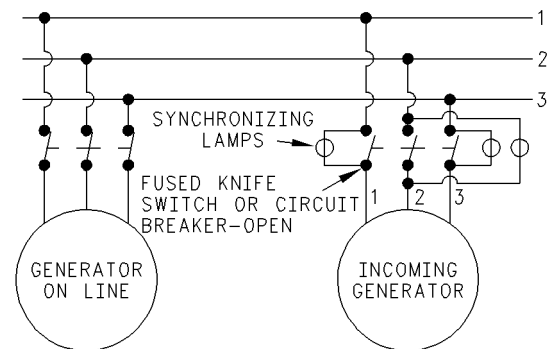

Illustration 49

g00695380

WARNING

When servicing or repairing electric power generation equipment:

Make sure the unit is off-line (disconnected from utility and/or other generators power service), and either locked out or tagged DO NOT OPERATE. Remove all fuses.

- Connect the light bulbs with rated voltage between the generator leads and the corresponding line phase. For example, connect terminal 1 to line 1 across the open circuit breaker.
- Start the units that will be in operating in parallel. Bring the units up to speed. As the units approach the same speed, the lights will start to blink.
 - If the lights blink in sequence, one of the units is connected backward. In order to correct the problem, stop the units. Remove generator leads 1 and 3 at the circuit breaker. Exchange these generator leads. This reverses the direction of phase rotation. Terminal 2 should always be connected to line 2. Go to 5.

- Both generators have the same phase rotation when the lights blink in unison. The first condition of “Initial Start-Up” has been met.

2. Adjust the frequency.

The units that will be operating in parallel must operate at the same speed. Speed is proportional to the alternating current frequency.

- a. Allow each electric set to run under load for about 30 minutes.
- b. Adjust the control in order to give the rated frequency at full load.
- c. Remove the load and check the high idle speed. The high idle speed should be approximately 2 to 5 percent above full load speed for generators that are equipped with droop. If these speeds can not be obtained, contact your Caterpillar dealer.
- d. For the most consistent results, repeat 2.b and 2.c until the second condition of “Initial Start-Up” has been met.

3. Adjust the voltage.

The potentiometers should be at the initial settings. **Refer to Operation and Maintenance Manual, “Voltage Regulators”.**

Note: Make sure that the speed droop is identical for all of the engines before adjustments are made to the generator.

- a. Preset the unit for parallel operation by connecting the current transformer to S1 and S2 of the connector J2. Set potentiometer P1 for quadrature droop in the center position. Apply the rated load. The voltage should drop for 2% to 3%. Switch the positions of the two incoming secondary wires of the current transformer if the voltage increases.
- b. The no-load voltages should be identical for all the generators that are operating in parallel. Connect the generators in parallel. Try to obtain a 0 kW power exchange by adjusting the speed of the generator. Try to minimize the circulating currents between generators by altering the voltage setting with potentiometer P2 or Rhe on one of the generators.

Note: Do not change the voltage settings after this step.

- c. Apply the available load. The setting is correct only if a reactive load is available. Equalize the Kilowatts or divide the rated power of the units proportionally by altering the speed. Alter the quadrature droop potentiometer (P1) in order to equalize the currents or divide the currents.

Starting Multiple Units

Use the procedure for starting single units in order to start multiple units. Refer to Operation Section, “Single Unit Operation”.

Paralleling Multiple Units

Units may be paralleled at no load. Units may also be paralleled with units under load. After the initial conditions for start-up are satisfied, verify for the following requirements:

- Generators must have voltage droop compensation or cross current compensation.
1. Start the unit which will be paralleled.
 2. Turn on the synchronizer lights.
 3. After the engine has run a few minutes, bring the engine up to synchronous speed. This means that the frequency of the incoming unit will be the same frequency as the unit that is on-line. The synchronizing lights will begin to blink.

Note: The frequency of the incoming unit should be slightly greater than the line frequency. This will allow the incoming unit to assume some of the load instead of adding to the system load.

4. By using the control, adjust the engine speed until the lights blink very slowly.
5. The lights are off when the voltages of the two units are in-phase. At this point, very quickly close the breaker while the lights are out.
6. Use the controls in order to share kW load between engines.
7. Generator temperature will be stabilized in approximately one hour. After the generator temperature has been stabilized, adjust the voltage droop rheostat of each generator. This will share the reactive load and this will limit the circulating currents. Less droop increases the reactive current that is carried by the generator. Adjusting the voltage droop rheostat in a counterclockwise direction will decrease the droop. Adjusting the voltage droop rheostat in a clockwise direction will increase droop.

Load Division and Speed Droop (If Equipped)

Once two units have been paralleled, the unit's share of the kW load is determined by the control setting. If two units of the same capacity and the same characteristics have the same control settings, the units will share the load equally. The total load must not exceed the capacity of the one engine.

In order to transfer the load from one engine to another engine, use the following procedure:

1. Increase the speed control of one unit in order to increase the load.
2. Reduce the speed control of the other unit in order to decrease the load on that unit.
3. Raise the speed control or lower the speed control of both units in order to change system frequency.

Stopping

In order to remove a generator from the line, perform the following procedure.

1. Check the load. The load must be less than the rated capacity of the remaining units.
2. Be sure that the neutral of one of the remaining units is grounded.
3. Remove the load from the outgoing unit. See the Parallel Operation, "Load Division - Speed Droop". The amperage may never go to zero due to circulating currents.
4. Open the circuit breaker.
5. Allow the engine to cool for five minutes.
6. Stop the engine.

Circulating Currents

Understanding the circulating currents becomes very important when you parallel the units. These circulating currents are flowing between generators in parallel operation. The circulating currents are caused by voltage differences between the generators. The circulating currents are not doing useful work. The amount of the circulating current can be determined by subtracting the amperage which is going to the load from the total generator amperage.

The circulating current may be as high as 25 percent of rated amperes with cold generator sets. Such current may not even be considered harmful. The total generator current should not exceed the amperage rating.

As the generators warm, the circulating currents will decrease. The ammeter readings should decrease slightly, but the voltage meter readings should remain constant.

i01490164

Single Unit Operation

SMCS Code: 4450

Initial Start-Up

Before the initial start-up, perform the megohmmeter test on the main stator winding. Refer to the Special Instruction, SEHS9124, "Cleaning and Drying of Electric Set Generators" for the procedure.

Starting

1. Make all preliminary engine starting checks.
2. Be sure that the main circuit breaker or the line circuit breaker is open.
3. Start the engine. Allow the engine to warm up.
4. Adjust to the full load engine speed.
5. Close the main circuit breaker.
6. Apply the load. Do not try to apply the full load. Apply the load in increments in order to maintain system frequency at a constant level.
7. Readjust the governor for rated frequency.

Stopping

1. Remove the load in increments.
2. Open the circuit breaker.
3. Allow the engine to run for five minutes in order to cool.
4. Stop the engine.

Voltage Regulators

i02303476

Voltage Regulators

SMCS Code: 4467

Caterpillar Digital Voltage Regulator (CDVR)

⚠ DANGER

The Cat Digital Voltage Regulator presents an electrical shock/electrocution hazard. This hazard will cause serious injury or death.

Service by trained personnel only.

The terminals and heat sinks are live at hazardous voltages when power is applied and for up to 8 minutes after power is removed.

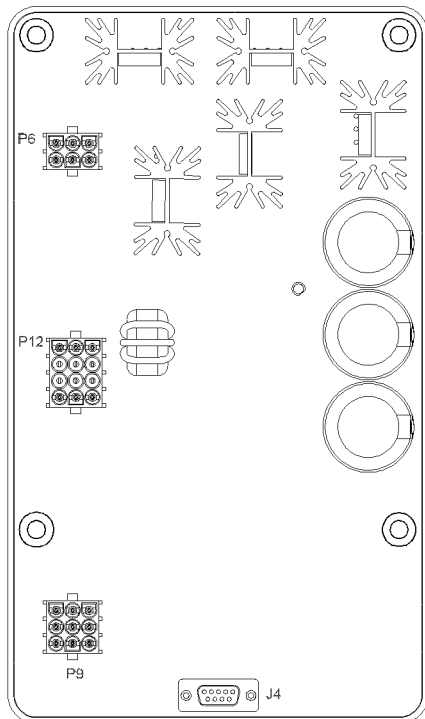

Illustration 50

g01115009

The Caterpillar Digital Voltage Regulator (CDVR) is a microprocessor based voltage regulator. Control power for the CDVR is supplied from an external source of 24 VDC. The power stage of the CDVR can be supplied from a multiple pole, high frequency, permanent magnet generator, from the generator output (shunt excitation), or from auxiliary windings that are included on some generators. Connections to the CDVR are made through three connectors. The communication between the CDVR and the service tool is accomplished by using a CANBUS protocol.

The CDVR has the following features:

- Three control modes:
 1. Automatic voltage regulation (AVR)
 2. Power factor (PF) regulation
 3. Reactive power (VAR) regulation
- Programmable stability settings
- Soft start control with an adjustable time setting in AVR mode
- Dual slope voltage versus frequency (V/Hz) characteristic
- Three-phase or single-phase voltage sensing
- Single-phase current sensing
- Field current sensing and field voltage sensing
- Ten protection functions

Adjusting the Caterpillar Digital Voltage Regulator (CDVR)

In order to view and configure the parameters of the CDVR, a PC with the Caterpillar PC software is required.

Refer to Specifications, Systems Operation, Testing and Adjusting, RENR7941, "Caterpillar Digital Voltage Regulator (CDVR)" for complete information.

i01809359

Voltage Regulator Options

SMCS Code: 4467

Manual Voltage Control

A manual voltage control is available as an option on Caterpillar generator sets. Various specifications and certifications require manual voltage control of the generator if the automatic voltage regulator should fail. The manual voltage control for the permanent magnet excited generators is shown below.

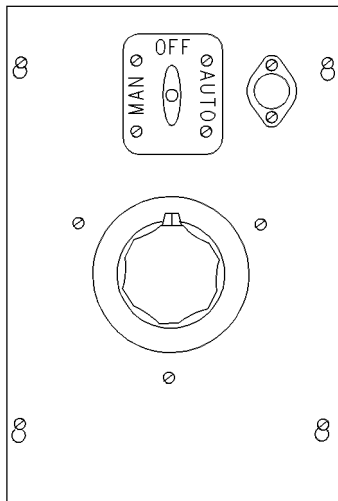

Illustration 51

g00626639

Manual voltage control for permanent magnet excited generators

Maintenance Section

Refill Capacities

i02874979

Refill Capacities and Recommendations

SMCS Code: 1348; 1395; 7560

Lubrication System

Lubricant Recommendations

Due to significant variations in the quality and in the performance of commercially available oils, Caterpillar recommends the following oils:

- **Cat DEO (Diesel Engine Oil) (10W-30)**
- **Cat DEO (Diesel Engine Oil) (15W-40)**

Note: If Cat DEO Multigrade is not used, use only commercial oils that meet the following classifications.

- API CH-4 multigrade oils and API CI-4 multigrade oils are acceptable if the requirements of Caterpillar's ECF-1 (Engine Crankcase Fluid specification 1) are met. API CH-4 oils and API CI-4 oils that have not met the requirements of Caterpillar's ECF-1 Specification may cause reduced engine life.
- API CG-4 multigrade oils are acceptable for all Caterpillar diesel engines. When API CG-4 oils are used, the oil drain interval should not exceed the standard oil drain interval for your engine.

The proper SAE viscosity grade of oil is determined by the minimum ambient temperature during cold engine start-up, and the maximum ambient temperature during engine operation. To determine the oil viscosity that is required for starting a cold soaked engine, refer to the minimum temperature in Table 2. To select the oil viscosity for operation at the highest anticipated ambient temperature, refer to the maximum temperature in the Table. Use the highest oil viscosity that is available in order to meet the required temperature during start-up.

Table 2

Engine Oil Viscosities for Ambient Temperatures		
Viscosity Grade	Ambient Temperature	
	Minimum	Maximum
SAE 0W-20	-40 °C (-40 °F)	10 °C (50 °F)
SAE 0W-30	-40 °C (-40 °F)	30 °C (86 °F)
SAE 0W-40	-40 °C (-40 °F)	40 °C (104 °F)
SAE 5W-30	-30 °C (-22 °F)	30 °C (86 °F)
SAE 5W-40	-30 °C (-22 °F)	50 °C (122 °F)
SAE 10W-30	-18 °C (0 °F)	40 °C (104 °F)
SAE 10W-40	-18 °C (0 °F)	50 °C (122 °F)
SAE 15W-40	-9.5 °C (15 °F)	50 °C (122 °F)

Refer to Special Publication, SEBU6251, "Caterpillar Commercial Diesel Engine Fluids Recommendations" for additional information that relates to lubricants.

Lubricant Capacities

The capacity of the engine lubrication system includes the capacity of the oil filters that are installed at the factory. Auxiliary oil filter systems (if equipped) will require additional oil. Refer to the specifications that are provided by the OEM of the auxiliary oil filter system.

Table 3

C27 and C32 Engine Approximate Refill Capacities		
Compartment or System	Liters	Quarts
Engine Crankcase Standard Sump	72	76
Engine Crankcase Deep Sump	99	104

Fuel

Fuel Recommendations

In North America, diesel fuel that is identified as No. 1-D or No. 2-D in "ASTM D975" generally meet the specifications. These fuels are distilled from crude oil. Diesel fuels from other sources could exhibit detrimental properties that are not defined or controlled by this specification.

Refer to Special Publication, SEBU6251, "Caterpillar Commercial Diesel Engine Fluids Recommendations" for additional information that relates to diesel fuel.

Cooling System

Coolant Recommendations

NOTICE

Do not use a commercial coolant/antifreeze that only meets the ASTM "D3306" specification. This type of coolant/antifreeze is made for light duty automotive applications.

Use only the coolant/antifreeze that is recommended.

The following coolants are the primary types of coolants that are used in Caterpillar Engines:

Preferred – Cat ELC (Extended Life Coolant) or a commercial extended life coolant that meets the Caterpillar EC-1 specification

Acceptable – Cat DEAC (Diesel Engine Antifreeze/Coolant) or a commercial heavy-duty coolant/antifreeze that meets "ASTM D4985" or "ASTM D5345" specifications

Caterpillar recommends a 1:1 mixture of water and glycol. This mixture will provide optimum heavy-duty performance as a coolant/antifreeze.

Note: Cat DEAC DOES NOT require a treatment with an SCA at the initial fill. Commercial heavy-duty antifreeze/coolant that meets "ASTM D4985" or "ASTM D5345" specifications MAY require a treatment with an SCA at the initial fill. Read the label or the instructions that are provided by the OEM of the product.

In stationary engine applications and marine engine applications that do not require protection from boiling or freezing, a mixture of SCA and water is acceptable. **Caterpillar recommends a minimum of six percent to a maximum of eight percent SCA concentration in those cooling systems.** Distilled water or deionized water is preferred. Water which has the required properties may be used. For the water properties, refer to Special Publication, SEBU6251, "Caterpillar Commercial Diesel Engine Fluids Recommendations" for additional information that pertains to coolants.

Note: Table 4 is a list of the coolants that are recommended and the service life (calendar) of the coolants. The service life of coolant is also limited by use (service hours). Refer to the specific engine's Operation and Maintenance Manual, "Maintenance Interval Schedule". **To achieve this service life, the coolants must be properly maintained. The maintenance program includes S-O-S coolant analysis.**

Table 4

Coolant Service Life	
Coolant Type	Service Life ⁽¹⁾
Cat ELC	Six Years
Cat DEAC	Three Years
Commercial Heavy-Duty Coolant/Antifreeze that meets "ASTM D5345"	Two Years
Commercial Heavy-Duty Coolant/Antifreeze that meets "ASTM D4985"	One Year
Caterpillar SCA and Water	Two Years
Commercial SCA and Water	One Year

(1) The service life of coolant is also limited by use (service hours). Refer to the specific engine's Operation and Maintenance Manual, "Maintenance Interval Schedule" (Maintenance Section).

Coolant Capacities

To properly maintain the cooling system, the total cooling system capacity must be determined. The total cooling system capacity will vary between individual installations. The total cooling system capacity can include the following components: engine, expansion tank, radiator, and piping.

Refer to the specifications that are provided by Caterpillar or the OEM of the installation. Record the total cooling system capacity in the appropriate Table.

Table 5

C27 and C32 Engine Approximate Refill Capacities		
Compartment or System	Liters	Quarts
Engine Only	55	58
External System (OEM) ⁽¹⁾		
Total Cooling System ⁽²⁾		

(1) The External System includes a radiator or an expansion tank with the following components: heat exchanger, aftercooler, and piping. Refer to the Caterpillar specifications or the OEM specifications and enter the capacity for the External System in this row.

(2) The Total Cooling System includes the capacity for the engine plus the capacity for the external system. Enter the total in this row.

Maintenance Recommendations

General Maintenance Information

i01179728

SMCS Code: 4450; 7000

Note: Read the warnings and read the instructions that are contained in the Safety Section of this manual. These warnings and instructions must be understood before you perform any operation or any maintenance procedures.

Rotating electric machines are complex structures that are exposed to the following forms of stress:

- mechanical
- electrical
- thermal
- environmental

These stresses may be of varying magnitudes. The electrical insulation systems are very susceptible to damage that is caused by the stresses that are listed above. Exposure to these stresses may shorten the effective life of the electrical insulation system. Therefore, the service life of an electric machine will largely depend on the serviceability of the electrical insulation systems. An inspection program and a testing procedure are recommended. An inspection program and a testing procedure will ensure that the equipment is maintained in satisfactory condition. This will increase field reliability.

A regular maintenance and inspection program can provide an evaluation of the present condition of the equipment. A regular maintenance program and a regular inspection program can also reveal future problems. The frequency of this maintenance program will depend on the following factors:

- application
- environmental conditions
- operator's experience
- operator's philosophy

A regular maintenance program is strongly recommended. This program would involve the following steps:

- periodic disassembly

- knowledgeable visual examination of the equipment
- the application of electrical tests

Never perform a test over the rated potential. These tests can damage insulation that is contaminated or insulation that is in marginal condition. For more information, refer to "I.E.E.E. Standard 432-1992" or consult a Caterpillar dealer.

i02909163

System Pressure Release

SMCS Code: 1250; 1300; 1350; 5050

Coolant System

WARNING

Pressurized system: Hot coolant can cause serious burn. To open cap, stop engine, wait until radiator is cool. Then loosen cap slowly to relieve the pressure.

To relieve the pressure from the coolant system, turn off the engine. Allow the cooling system pressure cap to cool. Remove the cooling system pressure cap slowly in order to relieve pressure.

Fuel System

To relieve the pressure from the fuel system, turn off the engine.

High Pressure Fuel Lines (If Equipped)

WARNING

Contact with high pressure fuel may cause fluid penetration and burn hazards. High pressure fuel spray may cause a fire hazard. Failure to follow these inspection, maintenance and service instructions may cause personal injury or death.

The high pressure fuel lines are the fuel lines that are between the high pressure fuel pump and the high pressure fuel manifold and the fuel lines that are between the fuel manifold and cylinder head. These fuel lines are different from fuel lines on other fuel systems.

This is because of the following differences:

- The high pressure fuel lines are constantly charged with high pressure.

- The internal pressures of the high pressure fuel lines are higher than other types of fuel system.

Before any service or repair is performed on the engine fuel lines, perform the following tasks:

1. Stop the engine.
2. Wait for ten minutes.

Do not loosen the high pressure fuel lines in order to remove air pressure from the fuel system.

Engine Oil

To relieve pressure from the lubricating system, turn off the engine.

i03091592

Welding on Engines with Electronic Controls

SMCS Code: 1000

NOTICE

Because the strength of the frame may decrease, some manufacturers do not recommend welding onto a chassis frame or rail. Consult the OEM of the equipment or your Caterpillar dealer regarding welding on a chassis frame or rail.

Proper welding procedures are necessary in order to avoid damage to the engine's ECM, sensors, and associated components. When possible, remove the component from the unit and then weld the component. If removal of the component is not possible, the following procedure must be followed when you weld on a unit that is equipped with a Caterpillar Electronic Engine. The following procedure is considered to be the safest procedure to weld on a component. This procedure should provide a minimum risk of damage to electronic components.

NOTICE

Do not ground the welder to electrical components such as the ECM or sensors. Improper grounding can cause damage to the drive train bearings, hydraulic components, electrical components, and other components.

Clamp the ground cable from the welder to the component that will be welded. Place the clamp as close as possible to the weld. This will help reduce the possibility of damage.

Note: Perform the welding in areas that are free from explosive hazards.

1. Stop the engine. Turn the switched power to the OFF position.
2. Disconnect the negative battery cable from the battery. If a battery disconnect switch is provided, open the switch.
3. Disconnect the J1/P1 and J2/P2 connectors from the ECM. Move the harness to a position that will not allow the harness to accidentally move back and make contact with any of the ECM pins.

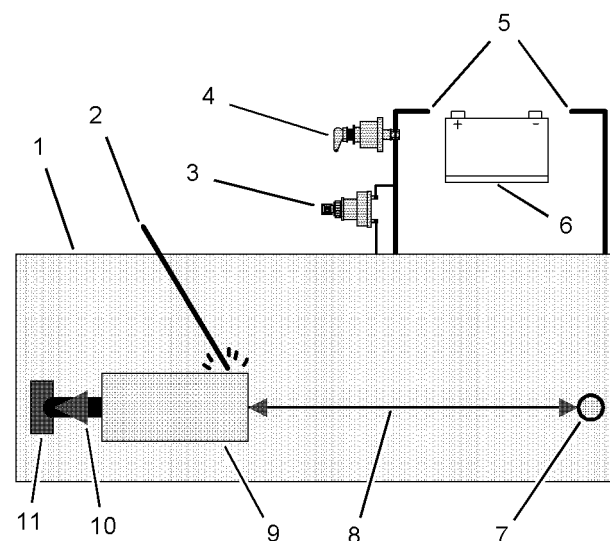

Illustration 52

g01075639

Use the example above. The current flow from the welder to the ground clamp of the welder will not cause damage to any associated components.

- (1) Engine
- (2) Welding electrode
- (3) Keyswitch in the OFF position
- (4) Battery disconnect switch in the open position
- (5) Disconnected battery cables
- (6) Battery
- (7) Electrical/Electronic component
- (8) Minimum distance between the component that is being welded and any electrical/electronic component
- (9) The component that is being welded
- (10) Current path of the welder
- (11) Ground clamp for the welder

4. Connect the welding ground cable directly to the part that will be welded. Place the ground cable as close as possible to the weld in order to reduce the possibility of welding current damage to bearings, hydraulic components, electrical components, and ground straps.

Note: If electrical/electronic components are used as a ground for the welder, or electrical/electronic components are located between the welder ground and the weld, current flow from the welder could severely damage the component.

5. Protect the wiring harness from welding debris and spatter.
6. Use standard welding practices to weld the materials.

i02364500

Generator Start-up Checklist

SMCS Code: 4450

Table 6

GENERATOR START-UP CHECKLIST						
RATING INFORMATION						
Engine Serial Number: _____				Arrangement Number: _____		
Generator Serial Number: _____				Arrangement Number: _____		
GENERATOR NAME PLATE INFORMATION						
Voltage: _____			Package (prime, continuous, standby): _____			
Amperage: _____			Kilowatts: _____			
Storage Location: _____						
Main Stator Megohmmeter Reading:		Before Storage:		After Storage:		
Generator dried for 24 hours prior to start-up?			(Y/N)		Drying method:	
SPACE HEATERS	Yes	No	Comments			
Space heaters operating properly?						
Space heater operated 48 hours before start-up?						
MEGOHMMETER TEST ("SEHS9124")	30 sec. reading	60 sec. reading	30 sec. corrected	60 sec. corrected	Ambient temp.	Comments
Beginning of Storage	Main Stator					
	Main Rotor					
	Exciter Stator					
	Exciter Rotor					
	PMG Stator					
Start-up	Main Stator					
	Main Rotor					
	Exciter Stator					
	Exciter Rotor					
	PMG Stator					
Regulator	Voltage	Amps	Comments			

(continued)

(Table 6, contd)

GENERATOR START-UP CHECKLIST				
No Load	"T1" to "T2"	AC		
	"T1" to "T3"	AC		
	"T2" to "T3"	AC		
	"11" to "12"	AC		
	"11" to "13"	AC		
	"12" to "13"	AC		
Full Load	"T1" to "T2"	AC		
	"T1" to "T3"	AC		
	"T2" to "T3"	AC		
	"11" to "12"	AC		
	"11" to "13"	AC		
	"12" to "13"	AC		

i03257578

Maintenance Interval Schedule (Standby)

SMCS Code: 1000; 4450; 7500

Ensure that all safety information, warnings and instructions are read and understood before any operation or any maintenance procedures are performed.

The user is responsible for the performance of maintenance, including all adjustments, the use of proper lubricants, fluids, filters, and the replacement of components due to normal wear and aging. Failure to adhere to proper maintenance intervals and procedures may result in diminished performance of the product and/or accelerated wear of components.

Use mileage, fuel consumption, service hours, or calendar time, WHICH EVER OCCURS FIRST, in order to determine the maintenance intervals. Products that operate in severe operating conditions may require more frequent maintenance.

Note: Before each consecutive interval is performed, all maintenance from the previous interval must be performed.

When Required

Battery - Recycle	77
Battery Charger - Check	78
Battery or Battery Cable - Disconnect	79
Fuel System - Prime	99
Generator - Dry	103
Generator Set - Test	106
Varistor - Test	121
Winding - Test	124

Daily

Cooling System Coolant Level - Check	89
Engine Oil Level - Check	95
Generator Load - Check	105
Power Factor - Check	114
Walk-Around Inspection	122

Every Week

Air Inlet Filter - Check	77
Battery Electrolyte Level - Check	78
Bearing Temperature - Measure/Record	83
Control Panel - Inspect	84
Electrical Connections - Check	93
Engine Air Cleaner Service Indicator - Inspect	94
Fuel System Primary Filter/Water Separator - Drain	102
Fuel Tank Water and Sediment - Drain	103
Generator - Inspect	104
Jacket Water Heater - Check	111

Space Heater - Check	116
Standby Generator Set Maintenance Recommendations	118
Stator Winding Temperature - Measure/Record ..	120
Voltage and Frequency - Check	122

Every 6 Months

Belts - Inspect/Adjust/Replace	83
Cooling System Coolant Sample (Level 1) - Obtain	89
Cooling System Supplemental Coolant Additive (SCA) - Test/Add	90
Heat Shield - Inspect/Replace	107
Stator Lead - Check	119

Every Year

Alternator - Inspect	77
Bearing (Ball) - Lubricate	79
Cooling System Coolant Sample (Level 2) - Obtain	90
Crankshaft Vibration Damper - Inspect	92
Engine - Clean	93
Engine Air Cleaner Element (Dual Element) - Clean/Replace	93
Engine Crankcase Breather - Clean	95
Engine Mounts - Check	95
Engine Oil Sample - Obtain	96
Engine Oil and Filter - Change	97
Engine Protective Devices - Check	98
Engine Valve Lash - Inspect/Adjust	98
Fan Drive Bearing - Lubricate	99
Fuel Injector - Inspect/Adjust	99
Fuel System Primary Filter (Water Separator) Element - Replace	101
Fuel System Secondary Filter - Replace	102
Generator Set Vibration - Inspect	107
Hoses and Clamps - Inspect/Replace	107
Insulation - Test	108
Prelube Pump - Inspect	114
Radiator - Clean	114
Speed Sensor - Clean/Inspect	116
Starting Motor - Inspect	119
Water Pump - Inspect	123

Every 3 Years

Batteries - Replace	77
Cooling System Water Temperature Regulator - Replace	92
Rotating Rectifier - Check	115
Turbocharger - Inspect	120

Every 3000 Service Hours or 3 Years

Cooling System Coolant (DEAC) - Change	85
--	----

Every 6000 Service Hours or 3 Years

Cooling System Coolant Extender (ELC) - Add	88
---	----

Every 12 000 Service Hours or 6 Years

Cooling System Coolant (ELC) - Change 87

i03257575

Maintenance Interval Schedule (Standard)

SMCS Code: 1000; 4450; 7500

Ensure that all safety information, warnings and instructions are read and understood before any operation or any maintenance procedures are performed.

The user is responsible for the performance of maintenance, including all adjustments, the use of proper lubricants, fluids, filters, and the replacement of components due to normal wear and aging. Failure to adhere to proper maintenance intervals and procedures may result in diminished performance of the product and/or accelerated wear of components.

Use mileage, fuel consumption, service hours, or calendar time, WHICH EVER OCCURS FIRST, in order to determine the maintenance intervals. Products that operate in severe operating conditions may require more frequent maintenance.

Note: Before each consecutive interval is performed, all maintenance from the previous interval must be performed.

When Required

Batteries - Replace	77
Battery - Recycle	77
Battery or Battery Cable - Disconnect	79
Engine - Clean	93
Fuel System - Prime	99
Generator - Dry	103
Generator Set - Test	106
Varistor - Test	121
Winding - Test	124

Daily

Bearing Temperature - Measure/Record	83
Control Panel - Inspect	84
Cooling System Coolant Level - Check	89
Engine Air Cleaner Service Indicator - Inspect	94
Engine Oil Level - Check	95
Fuel System Primary Filter/Water Separator - Drain	102
Fuel Tank Water and Sediment - Drain	103
Generator Load - Check	105
Jacket Water Heater - Check	111
Power Factor - Check	114
Walk-Around Inspection	122

Every Week

Air Inlet Filter - Check	77
Battery Charger - Check	78
Electrical Connections - Check	93

Generator - Inspect	104
Space Heater - Check	116
Stator Winding Temperature - Measure/Record ..	120
Voltage and Frequency - Check	122

Initial 250 Service Hours

Engine Valve Lash - Inspect/Adjust	98
Fuel Injector - Inspect/Adjust	99

Every 250 Service Hours

Battery Electrolyte Level - Check	78
Belts - Inspect/Adjust/Replace	83
Cooling System Coolant Sample (Level 1) - Obtain	89
Cooling System Supplemental Coolant Additive (SCA) - Test/Add	90
Fan Drive Bearing - Lubricate	99
Radiator - Clean	114

Initial 500 Hours (for New Systems, Refilled Systems, and Converted Systems)

Cooling System Coolant Sample (Level 2) - Obtain	90
--	----

Every 2000 Service Hours

Engine Mounts - Check	95
Fuel Injector - Inspect/Adjust	99
Generator Set Vibration - Inspect	107
Insulation - Test	108
Stator Lead - Check	119

Every Year

Bearing (Ball) - Lubricate	79
Cooling System Coolant Sample (Level 2) - Obtain	90

Every 3000 Service Hours or 3 Years

Cooling System Coolant (DEAC) - Change	85
--	----

Every 6000 Service Hours or 3 Years

Cooling System Coolant Extender (ELC) - Add	88
--	----

Every 6000 Service Hours or 6 Years

Alternator - Inspect	77
Prelube Pump - Inspect	114
Speed Sensor - Clean/Inspect	116

Every 8000 Service Hours

Rotating Rectifier - Check	115
----------------------------------	-----

Every 12 000 Service Hours or 6 Years

Cooling System Coolant (ELC) - Change	87
---	----

Every 19 000 L (5000 US gal) of Fuel or 250 Service Hours

Engine Air Cleaner Element (Dual Element) - Clean/Replace	93
Engine Oil Sample - Obtain	96
Engine Oil and Filter - Change	97
Engine Protective Devices - Check	98
Fuel System Secondary Filter - Replace	102
Heat Shield - Inspect/Replace	107
Hoses and Clamps - Inspect/Replace	107

Every 38 000 L (10 000 US gal) of Fuel or 500 Service Hours

Engine Crankcase Breather - Clean	95
Fuel System Primary Filter (Water Separator) Element - Replace	101

Every 228 000 L (60 000 US gal) of Fuel or 3000 Service Hours

Cooling System Water Temperature Regulator - Replace	92
Crankshaft Vibration Damper - Inspect	92
Engine Valve Lash - Inspect/Adjust	98

Every 379 000 L (100 000 US gal) of Fuel or 5000 Service Hours

Starting Motor - Inspect	119
Turbocharger - Inspect	120
Water Pump - Inspect	123

Overhaul

Bearing - Inspect	80
Overhaul Considerations	111

i02574676

Air Inlet Filter - Check

SMCS Code: 1051-535

Monitor the connector contacts of the differential pressure switch for the air inlet filter. If the differential pressure rises above 0.15 kPa (0.6 inch of H₂O) of water, clean the filter with a solution of soap and water. Be sure that the filter is thoroughly dry before the start-up. Replace the filter, if necessary.

i02676048

Alternator - Inspect

SMCS Code: 1405-040

Caterpillar recommends a scheduled inspection of the alternator. Inspect the alternator for loose connections and proper battery charging. Inspect the ammeter (if equipped) during engine operation in order to ensure proper battery performance and/or proper performance of the electrical system. Make repairs, as required.

Check the alternator and the battery charger for proper operation. If the batteries are properly charged, the ammeter reading should be very near zero. All batteries should be kept charged. The batteries should be kept warm because temperature affects the cranking power. If the battery is too cold, the battery will not crank the engine. The battery will not crank the engine, even if the engine is warm. When the engine is not run for long periods of time or if the engine is run for short periods, the batteries may not fully charge. A battery with a low charge will freeze more easily than a battery with a full charge.

i01041029

Batteries - Replace

SMCS Code: 1401-510

WARNING

Batteries give off combustible gases which can explode. A spark can cause the combustible gases to ignite. This can result in severe personal injury or death.

Ensure proper ventilation for batteries that are in an enclosure. Follow the proper procedures in order to help prevent electrical arcs and/or sparks near batteries. Do not smoke when batteries are serviced.

1. Turn the key start switch to the OFF position. Remove the key and all electrical loads.
2. Turn OFF the battery charger. Disconnect the charger.
3. The NEGATIVE “-” cable connects the NEGATIVE “-” battery terminal to the ground plane. Disconnect the cable from the NEGATIVE “-” battery terminal.
4. The POSITIVE “+” cable connects the POSITIVE “+” battery terminal to the starting motor. Disconnect the cable from the POSITIVE “+” battery terminal.

Note: Always recycle a battery. Never discard a battery. Return used batteries to an appropriate recycling facility.

5. Remove the used battery.
6. Install the new battery.

Note: Before connecting the cables, ensure that the key start switch is OFF.

7. Connect the cable from the starting motor to the POSITIVE “+” battery terminal.
8. Connect the cable from the ground plane to the NEGATIVE “-” battery terminal.

i00993589

Battery - Recycle

SMCS Code: 1401-005; 1401-510; 1401-535; 1401-561; 1401

Always recycle a battery. Never discard a battery.

Always return used batteries to one of the following locations:

- A battery supplier
- An authorized battery collection facility
- Recycling facility

i01039758

Battery Charger - Check

SMCS Code: 1401-535

Checking Before Start-Up

Check the battery charger for proper operation. If the batteries are properly charged, the needle of the ammeter will register near "0" (zero).

The battery charger must not produce excessive current during start-up. Alternatively, the charger must be automatically disconnected for start-up. If the engine has an alternator, the charger must be automatically disconnected during start-up and during engine operation.

Charging the Battery

WARNING

Never disconnect any charging unit circuit or battery circuit cable from the battery when the charging unit is operated. A spark can cause an explosion from the flammable vapor mixture of hydrogen and oxygen that is released from the electrolyte through the battery outlets. Injury to personnel can be the result.

Perform the following procedure to charge the battery:

1. Ensure that the charger is turned OFF.
2. Adjust the voltage of the charger in order to match the voltage of the battery.
3. Connect the POSITIVE "+" lead of the charger to the POSITIVE "+" battery terminal. Connect the NEGATIVE "-" lead of the charger to the NEGATIVE "-" battery terminal.
4. Turn ON the battery charger.

Overcharging of Batteries

Overcharging reduces the service life of batteries. Use a battery charger that will not overcharge the battery. DO NOT charge the battery if the meter of the battery charger is in the RED zone.

Overcharging is indicated by the following symptoms:

- The battery is very warm to the touch.
- A strong odor of acid is present.
- The battery emits smoke or a dense vapor (gas).

Perform one of the following procedures if the battery shows symptoms of overcharging:

- Reduce the rate of charging by a significant amount. Complete the charging at the reduced rate.
- Turn OFF the charger.

Table 8 describes the effects of overcharging on different types of batteries.

Table 8

Effects of Overcharging Batteries	
Type of Battery	Effect
Caterpillar General Service Batteries Caterpillar Premium High Output Batteries	All of the battery cells have a low level of electrolyte.
	When the plates of the battery are inspected through the filler holes, the plates may appear to be warped. This is caused by an excessive temperature.
	The battery may not pass a load test.
Caterpillar Maintenance Free Batteries	The battery may not accept a charging current.
	The battery may not pass a load test.

Checking After Stopping

Ensure that the battery charger is connected properly. Observe the meter of the charger. Record the amperage.

i02601752

Battery Electrolyte Level - Check

SMCS Code: 1401-535-FLV

When the engine is not run for long periods of time or when the engine is run for short periods, the batteries may not fully recharge. Ensure a full charge in order to help prevent the battery from freezing.

WARNING

All lead-acid batteries contain sulfuric acid which can burn the skin and clothing. Always wear a face shield and protective clothing when working on or near batteries.

1. Remove the filler caps. Maintain the electrolyte level to the "FULL" mark on the battery.

If the addition of water is necessary, use distilled water. If distilled water is not available use clean water that is low in minerals. Do not use artificially softened water.

2. Check the condition of the electrolyte with the 245-5829 Coolant Battery Tester Refractometer.
3. Keep the batteries clean.

Clean the battery case with one of the following cleaning solutions:

- A mixture of 0.1 kg (0.2 lb) of baking soda and 1 L (1 qt) of clean water
- A mixture of 0.1 L (0.11 qt) of ammonia and 1 L (1 qt) of clean water

Thoroughly rinse the battery case with clean water.

Use a fine grade of sandpaper to clean the terminals and the cable clamps. Clean the items until the surfaces are bright or shiny. DO NOT remove material excessively. Excessive removal of material can cause the clamps to not fit properly. Coat the clamps and the terminals with 5N-5561 Silicone Lubricant, petroleum jelly or MPMG.

i01857537

Battery or Battery Cable - Disconnect

SMCS Code: 1401; 1402-029

WARNING

The battery cables or the batteries should not be removed with the battery cover in place. The battery cover should be removed before any servicing is attempted.

Removing the battery cables or the batteries with the cover in place may cause a battery explosion resulting in personal injury.

1. Switch the engine to the OFF position. Turn the ignition switch (if equipped) to the OFF position and remove the key and all electrical loads.
2. Disconnect the negative battery terminal at the battery that goes to the start switch. Ensure that the cable cannot contact the terminal.
3. Tape the leads in order to help prevent accidental starting.
4. Proceed with necessary system repairs. Reverse the steps in order to reconnect all of the cables.

i02903637

Bearing (Ball) - Lubricate (Generator)

SMCS Code: 4471-086

For ball bearings, use Caterpillar 2S-3230 Bearing Lubricant. This grease is an NLGI No. 2 Grade. There is Polyurea (a thickener) in this grease. The temperature range of Caterpillar 2S-3230 Bearing Lubricant is -29°C (-20.2°F) to 177°C (350.6°F). For extremely low temperatures, use either NLGI No. 1 Grade or NLGI No. 0 Grade.

Lubricating Process

1. Remove either the louver assembly or the rear plate from the rear of the generator housing.
2. Remove the top grease pipe plug and remove the lower grease pipe plug.
3. Install a grease fitting in the grease pipe.
4. Grease the shielded ball bearings with 2S-3230 Bearing Lubricant (53.28 mL (1.8 ounces) to 59.20 mL (2.0 ounces)). Lubricate shielded ball bearings at 2000 hour intervals. Do not mix greases.

Note: Some two-bearing generators have spherical roller bearings in the front bracket and ball bearings in the rear bracket. These units should use a common 108-8611 Grease Cartridge. This grease should be used for the front bearing and the rear bearing.

5. Wipe off the excess grease. Remove the top grease fitting. Install the plug.

6. Operate the generator for one hour. This will allow the grease to expand. The expanding grease will force the excess grease from the cavity. When the excess grease is forced from the cavity, the internal pressure will be reduced. The generator should continue to operate until the grease stops purging.
7. Stop the engine. Install the plug in the bottom grease pipe. Wipe off the excess grease.
8. Install the louver assembly or install the rear plate.

i02230503

Bearing - Inspect

SMCS Code: 4471-040

The following maintenance procedure for generator bearings should be followed at every major engine overhaul:

1. Remove the bearing bracket. Inspect the following items: bracket bore, bearing outer race, and rolling elements. On standby power units, the bearing must be inspected and the grease must be replaced at three year intervals. The sleeve for the bearing bracket should be inspected for out of roundness, excessive wear, and a bracket step that is less than 0.0762 mm (0.0030 inch). If there is no sleeve for the bearing bracket, inspect the bore for the bearing bracket. The bearing should be inspected for damage to the outer race, severe fretting, and smoothness of operation. When possible, the bearing elements should be inspected. Some double shielded ball bearings prevent visual inspection of the ball bearings. Other double shielded ball bearings have a retaining ring. This retaining ring can be removed in order to allow access for a visual inspection of the ball bearings.

On two-bearing generators, the front bearing can only be removed after the hub is removed. In order to remove the hub, cut off the hub. Pulling the hub will damage the shaft.

Note: Bearings that are being removed for failure analysis should not be cut off with a torch.

2. Spherical Roller Bearing should be cleaned and repacked with 108-8611 Grease. Pack the bearing and pack the cavity (one-third to one-half of the volume of the cavity). The bearing should be filled with 88.8 mL (3 ounces) to 118.4 mL (4 ounces) of grease. The cavity should be filled with 118.4 mL (4 ounces) to 148.0 mL (5 ounces) of grease. Refer to Table 9.

3. All ball bearings should be cleaned. The cavity of the bracket should be repacked with 2S-3230 Grease. Pack the bearings (one-third to one-half of the volume of the cavity). Refer to Table 9.

To reinstall bearings, heat the bearings to 107 °C (224.6 °F) for ten minutes. Mount the bearings on the shaft. To reinstall the hub, heat the hub to 400 °C (752.0 °F) for three hours. Mount the hub to the shaft.

4. Ensure that the tube that supplies grease to the bearing is filled with grease.
5. Remove the bracket drain plug and operate the generator for one hour. This will allow the grease to expand. The expanding grease will force the excess grease from the cavity. When the excess grease is forced from the cavity, the internal pressure will be reduced. The generator should continue to operate until the grease stops purging.
6. Stop the engine. Install the bracket drain plug. Wipe off the excess grease.
7. For greasing intervals, follow the recommendations on the lubrication plate (if equipped) or refer to Maintenance Schedule, "Bearing - Lubricate". Whenever the bearings are greased, repeat Step 5. DO NOT MIX GREASES.

Table 9

Bearing Outside Diameter mm (inch)	Bearing Inside Diameter mm (inch)	Part Number	Generator Frame Size	Bearing Bore in Bracket mm (inch)	Bearing Shield (Type)	Bearing Cavity Grease mL (oz)	Rotor Shaft Diameter mm (inch)
100.000 mm (3.9370 inch)	45.000 mm (1.7717 inch)	5P - 1977	All 360	100.000 mm (3.9370 inch) to 100.025 mm (3.9380 inch)	Double	29.6 mL (1 oz)	45.004 mm (1.7718 inch) to 45.019 mm (1.7724 inch)
140.000 mm (5.5118 inch)	65.000 mm (2.5591 inch)	3N - 1965	440 (round laminated)	140.002 mm (5.5119 inch) to 140.028 mm (5.5129 inch)	Double	53.280 mL (1.8 oz) ⁽¹⁾ to 94.720 mL (3.2 oz) ⁽²⁾	65.004 mm (2.5592 inch) to 65.021 mm (2.5599 inch)
160.000 mm (6.2992 inch)	75.000 mm (2.9527 inch)	5P - 2448	580 ⁽²⁾ 590 ⁽¹⁾	160.002 mm (6.2993 inch) to 160.028 mm (6.3003 inch)	Double	100.64 mL (3.4 oz) to 168.72 mL (5.7 oz)	75.004 mm (2.9529 inch) to 75.021 mm (2.9536 inch)
170.000 mm (6.6929 inch)	80.000 mm (3.1496 inch)	4L - 6677 ⁽³⁾	580 ⁽¹⁾	170.002 mm (6.6930 inch) to 170.028 mm (6.6940 inch)	Single	97.68 mL (3.3 oz) to 162.80 mL (5.5 oz)	80.002 mm (3.1497 inch) to 80.020 mm (3.1504 inch)
170.000 mm (6.6929 inch)	80.000 mm (3.1496 inch)	109 - 7687 ⁽³⁾	580 ⁽¹⁾	170.002 mm (6.6930 inch) to 170.028 mm (6.6940 inch)	Double	97.68 mL (3.3 oz) to 162.80 mL (5.5 oz)	80.002 mm (3.1497 inch) to 80.020 mm (3.1504 inch)
180.000 mm (7.0866 inch)	100.000 mm (3.9370 inch)	6Y - 3955	440 (square laminated)	179.992 mm (7.0863 inch) to 180.017 mm (7.0873 inch)	Double	139.12 mL (4.7 oz) to 230.88 mL (7.8 oz)	100.012 mm (3.9375 inch) to 100.028 mm (3.9381 inch)
190.000 mm (7.4803 inch)	90.000 mm (3.5433 inch)	6Y - 6488	590 ⁽¹⁾ 589 PM	190.002 mm (7.4804 inch) to 190.028 mm (7.4814 inch)	Double	97.68 mL (3.3 oz) to 162.80 mL (5.5 oz)	90.012 mm (3.5438 inch) to 90.028 mm (3.5444 inch)

(continued)

(Table 9, contd)

Bearing Outside Diameter mm (inch)	Bearing Inside Diameter mm (inch)	Part Number	Generator Frame Size	Bearing Bore in Bracket mm (inch)	Bearing Shield (Type)	Bearing Cavity Grease mL (oz)	Rotor Shaft Diameter mm (inch)
225.000 mm (8.8582 inch)	105.000 mm (4.1338 inch)	6V - 0410	680 ⁽¹⁾	225.003 mm (8.8584 inch) to 225.034 mm (8.8596 inch)	Single	139.12 mL (4.7 oz) to 230.88 mL (7.8 oz)	105.029 mm (4.1350 inch) to 105.034 mm (4.1352 inch)
225.000 mm (8.8582 inch)	105.000 mm (4.1338 inch)	108 - 1760	680 ⁽¹⁾	225.003 mm (8.8584 inch) to 225.034 mm (8.8596 inch)	Double	148.00 mL (5.0 oz) to 236.80 mL (8.0 oz)	105.029 mm (4.1350 inch) to 105.034 mm (4.1352 inch)
230.000 mm (9.0551 inch)	130.000 mm (5.1181 inch)	2L - 4444 ⁽⁴⁾	808 4 pole ⁽¹⁾	229.992 mm (9.0548 inch) to 230.022 mm (9.0560 inch)	Open	177.60 mL (6.0 oz) to 266.40 mL (9.0 oz)	130.028 mm (5.1192 inch) to 130.051 mm (5.1201 inch)
230.000 mm (9.0551 inch)	130.000 mm (5.1181 inch)	2L - 4444 ⁽⁴⁾	820 ⁽¹⁾	229.992 mm (9.0548 inch) to 230.022 mm (9.0560 inch)	Open	236.8 mL (8.0 oz) to 355.20 mL (12.0 oz)	130.028 mm (5.1192 inch) to 130.051 mm (5.1201 inch)
240.000 mm (9.4488 inch)	110.000 mm (4.3307 inch)	108 - 1761	690 ⁽¹⁾	240.002 mm (9.4489 inch) to 240.033 mm (9.4501 inch)	Double	207.20 mL (7.0 oz) to 296.00 mL (10.0 oz) ⁽²⁾ 414.40 mL (14.0 oz) to 621.60 mL (21 oz) ⁽³⁾	110.012 mm (4.3312 inch) to 110.028 mm (4.3318 inch)
240.000 mm (9.4488 inch)	110.000 mm (4.3307 inch)	6V - 3310	800 ⁽¹⁾	240.002 mm (9.4489 inch) to 240.033 mm (9.4501 inch)	Single	145.04 mL (4.9 oz) to 239.76 mL (8.1 oz)	110.012 mm (4.3312 inch) to 110.028 mm (4.3318 inch)
240.000 mm (9.4488 inch)	110.000 mm (4.3307 inch)	6V - 6752	800 ⁽¹⁾	240.002 mm (9.4489 inch) to 240.033 mm (9.4501 inch)	Single	145.04 mL (4.9 oz) to 239.76 mL (8.1 oz)	110.012 mm (4.3312 inch) to 110.028 mm (4.3318 inch)

(continued)

(Table 9, contd)

Bearing Outside Diameter mm (inch)	Bearing Inside Diameter mm (inch)	Part Number	Generator Frame Size	Bearing Bore in Bracket mm (inch)	Bearing Shield (Type)	Bearing Cavity Grease mL (oz)	Rotor Shaft Diameter mm (inch)
240.000 mm (9.4488 inch)	110.000 mm (4.3307 inch)	108-1761	800 ⁽¹⁾	240.002 mm (9.4489 inch) to 240.033 mm (9.4501 inch)	Double	148.00 mL (5.0 oz) to 236.80 mL (8.0 oz)	110.012 mm (4.3312 inch) to 110.028 mm (4.3318 inch)
280.000 mm (11.024 inch)	130.000 mm (5.1181 inch)	154-3032	820	280.002 mm (11.0237 inch) to 280.032 mm (11.0249 inch)	Double	N/A	130.028 mm (5.1192 inch) to 130.051 mm (5.1201 inch)

(1) Inboard bearing

(2) Outboard bearing

(3) 109-7687 bearing is preferred.

(4) This bearing is a spherical roller bearing. This bearing is greased from the bracket's front side. All of the other bearings are ball bearings.

(2) This bearing is on the same end as the exciter.

(3) This bearing is on the drive end of the generator.

i01952106

Bearing Temperature - Measure/Record

SMCS Code: 4471-082-TA

Bearing temperature detectors are optional on generators. Bearing temperature detectors are used with equipment that has been provided by the customer in order to measure the bearing temperature. Bearing temperature detectors may help to prevent premature bearing failure.

A bearing temperature that is 50 °C (122 °F) above the ambient temperature may require a change in operation. The unit should be shut down in order to prevent damage if the bearing temperature is 50 °C (122 °F) above the ambient temperature.

i02229322

Belts - Inspect/Adjust/Replace

SMCS Code: 1357-025; 1357-040; 1357-510

Inspection

Inspect the alternator belt and any accessory belts for wear and for cracking. Replace the belts if the belts are not in good condition.

Check the belt tension according to the information in the Service Manual, "Specifications".

Slippage of loose belts can reduce the efficiency of the driven components. Vibration of loose belts can cause unnecessary wear on the following components:

- Belts
- Pulleys
- Bearings

If the belts are too tight, unnecessary stress is placed on the components. This reduces the service life of the components.

Replacement

For applications that require multiple drive belts, replace the drive belts in matched sets. Replacing one drive belt of a matched set will cause the new drive belt to carry more load because the older drive belts are stretched. The additional load on the new drive belt could cause the new drive belt to fail.

It is possible to test the LED indicators and the horn when the data link is connected and when the data link is not connected. The Lamp Test button is located near the top of the annunciator panel. Test both the horn and the indicators by pressing and holding the Lamp Test button. Replace any faulty components before starting the engine.

i02056137

Cooling System Coolant (DEAC) - Change

SMCS Code: 1350-044

Clean the cooling system and flush the cooling system before the recommended maintenance interval if the following conditions exist:

- The engine overheats frequently.
- Foaming is observed.
- The oil has entered the cooling system and the coolant is contaminated.
- The fuel has entered the cooling system and the coolant is contaminated.

NOTICE

Use of commercially available cooling system cleaners may cause damage to cooling system components. Use only cooling system cleaners that are approved for Caterpillar engines.

Note: Inspect the water pump and the water temperature regulator after the cooling system has been drained. This is a good opportunity to replace the water pump, the water temperature regulator and the hoses, if necessary.

Drain

WARNING

Pressurized System: Hot coolant can cause serious burns. To open the cooling system filler cap, stop the engine and wait until the cooling system components are cool. Loosen the cooling system pressure cap slowly in order to relieve the pressure.

1. Stop the engine and allow the engine to cool. Loosen the cooling system filler cap slowly in order to relieve any pressure. Remove the cooling system filler cap.

2. Open the cooling system drain valve (if equipped). If the cooling system is not equipped with a drain valve, remove one of the drain plugs.

Allow the coolant to drain.

NOTICE

Dispose of used engine coolant properly or recycle. Various methods have been proposed to reclaim used coolant for reuse in engine cooling systems. The full distillation procedure is the only method acceptable by Caterpillar to reclaim the used coolant.

For information regarding the disposal and the recycling of used coolant, consult your Caterpillar dealer or consult Caterpillar Dealer Service Tools Group:

Outside Illinois: 1-800-542-TOOL
Inside Illinois: 1-800-541-TOOL
Canada: 1-800-523-TOOL

Flush

1. Flush the cooling system with clean water in order to remove any debris.
2. Close the drain valve (if equipped). Clean the drain plugs. Install the drain plugs. Refer to the Specifications Manual, SENR3130, "Torque Specifications" for more information on the proper torques.

NOTICE

Fill the cooling system no faster than 19 L (5 US gal) per minute to avoid air locks.

3. Fill the cooling system with a mixture of clean water and Caterpillar Fast Acting Cooling System Cleaner. Add 0.5 L (1 pint) of cleaner per 15 L (4 US gal) of the cooling system capacity. Install the cooling system filler cap.
4. Start and run the engine at low idle for a minimum of 30 minutes. The coolant temperature should be at least 82 °C (180 °F).

NOTICE

Improper or incomplete rinsing of the cooling system can result in damage to copper and other metal components.

To avoid damage to the cooling system, make sure to completely flush the cooling system with clear water. Continue to flush the system until all signs of the cleaning agent are gone.

5. Stop the engine and allow the engine to cool. Loosen the cooling system filler cap slowly in order to relieve any pressure. Remove the cooling system filler cap. Open the drain valve (if equipped) or remove the cooling system drain plugs. Allow the water to drain. Flush the cooling system with clean water. If equipped, be sure to flush the heater and any related supply and return lines. Close the drain valve (if equipped). Clean the drain plugs. Install the drain plugs. Refer to the Specifications Manual, SENR3130, "Torque Specifications" for more information on the proper torques.

Cooling Systems with Heavy Deposits or Plugging

Note: For the following procedure to be effective, there must be some active flow through the cooling system components.

1. Flush the cooling system with clean water in order to remove any debris.
2. Close the drain valve (if equipped). Clean the drain plugs. Install the drain plugs. Refer to the Specifications Manual, SENR3130, "Torque Specifications" for more information on the proper torques.

NOTICE

Fill the cooling system no faster than 19 L (5 US gal) per minute to avoid air locks.

3. Fill the cooling system with a mixture of clean water and Caterpillar Fast Acting Cooling System Cleaner. Add 0.5 L (1 pint) of cleaner per 3.8 to 7.6 L (1 to 2 US gal) of the cooling system capacity. Install the cooling system filler cap.
4. Start and run the engine at low idle for a minimum of 90 minutes. The coolant temperature should be at least 82 °C (180 °F).

NOTICE

Improper or incomplete rinsing of the cooling system can result in damage to copper and other metal components.

To avoid damage to the cooling system, make sure to completely flush the cooling system with clear water. Continue to flush the system until all signs of the cleaning agent are gone.

5. Stop the engine and allow the engine to cool. Loosen the cooling system filler cap slowly in order to relieve any pressure. Remove the cooling system filler cap. Open the drain valve (if equipped) or remove the cooling system drain plugs. Allow the water to drain. Flush the cooling system with clean water. Close the drain valve (if equipped). Clean the drain plugs. Install the drain plugs. Refer to the Specifications Manual, SENR3130, "Torque Specifications" for more information on the proper torques.

Fill

NOTICE

Fill the cooling system no faster than 19 L (5 US gal) per minute to avoid air locks.

1. Fill the cooling system with coolant/antifreeze. Refer to the Operation and Maintenance Manual, "Refill Capacities and Recommendations" topic (Maintenance Section) for more information on cooling system specifications. Do not install the cooling system filler cap.
2. Start and run the engine at low idle. Increase the engine rpm to 1500 rpm. Run the engine at high idle for one minute in order to purge the air from the cavities of the engine block. Stop the engine.
3. Check the coolant level. Maintain the coolant level within 13 mm (0.5 inch) below the bottom of the pipe for filling. Maintain the coolant level within 13 mm (0.5 inch) to the proper level on the sight glass (if equipped).
4. Clean the cooling system filler cap. Inspect the gasket that is on the cooling system filler cap. If the gasket that is on the cooling system filler cap is damaged, discard the old cooling system filler cap and install a new cooling system filler cap. If the gasket that is on the cooling system filler cap is not damaged, perform a pressure test. A 9S-8140 Pressurizing Pump is used to perform the pressure test. The correct pressure for the cooling system filler cap is stamped on the face of the cooling system filler cap. If the cooling system filler cap does not retain the correct pressure, install a new cooling system filler cap.
5. Start the engine. Inspect the cooling system for leaks and for proper operating temperature.

i02056152

Cooling System Coolant (ELC) - Change

SMCS Code: 1350-044-NL

Clean the cooling system and flush the cooling system before the recommended maintenance interval if the following conditions exist:

- The engine overheats frequently.
- Foaming is observed.
- The oil has entered the cooling system and the coolant is contaminated.
- The fuel has entered the cooling system and the coolant is contaminated.

Note: When the cooling system is cleaned, only clean water is needed when the ELC is drained and replaced.

Note: Inspect the water pump and the water temperature regulator after the cooling system has been drained. This is a good opportunity to replace the water pump, the water temperature regulator and the hoses, if necessary.

Drain

WARNING

Pressurized System: Hot coolant can cause serious burns. To open the cooling system filler cap, stop the engine and wait until the cooling system components are cool. Loosen the cooling system pressure cap slowly in order to relieve the pressure.

1. Stop the engine and allow the engine to cool. Loosen the cooling system filler cap slowly in order to relieve any pressure. Remove the cooling system filler cap.
2. Open the cooling system drain valve (if equipped). If the cooling system is not equipped with a drain valve, remove the cooling system drain plugs.

Allow the coolant to drain.

NOTICE

Dispose of used engine coolant properly or recycle. Various methods have been proposed to reclaim used coolant for reuse in engine cooling systems. The full distillation procedure is the only method acceptable by Caterpillar to reclaim the used coolant.

For information regarding the disposal and the recycling of used coolant, consult your Caterpillar dealer or consult Caterpillar Dealer Service Tool Group:

Outside Illinois: 1-800-542-TOOL
Inside Illinois: 1-800-541-TOOL
Canada: 1-800-523-TOOL

Flush

1. Flush the cooling system with clean water in order to remove any debris.
2. Close the drain valve (if equipped). Clean the drain plugs. Install the drain plugs. Refer to the Specifications Manual, SENR3130, "Torque Specifications" for more information on the proper torques.

NOTICE

Fill the cooling system no faster than 19 L (5 US gal) per minute to avoid air locks.

3. Fill the cooling system with clean water. Install the cooling system filler cap.
4. Start and run the engine at low idle until the temperature reaches 49 to 66 °C (120 to 150 °F).
5. Stop the engine and allow the engine to cool. Loosen the cooling system filler cap slowly in order to relieve any pressure. Remove the cooling system filler cap. Open the drain valve (if equipped) or remove the cooling system drain plugs. Allow the water to drain. Flush the cooling system with clean water. Close the drain valve (if equipped). Clean the drain plugs. Install the drain plugs. Refer to the Specifications Manual, SENR3130, "Torque Specifications" for more information on the proper torques.

Fill

NOTICE

Fill the cooling system no faster than 19 L (5 US gal) per minute to avoid air locks.

1. Fill the cooling system with Extended Life Coolant (ELC). Refer to the Operation and Maintenance Manual, "Refill Capacities and Recommendations" topic (Maintenance Section) for more information on cooling system specifications. Do not install the cooling system filler cap.
2. Start and run the engine at low idle. Increase the engine rpm to high idle. Run the engine at high idle for one minute in order to purge the air from the cavities of the engine block. Stop the engine.

3. Check the coolant level. Maintain the coolant level within 13 mm (0.5 inch) below the bottom of the pipe for filling. Maintain the coolant level within 13 mm (0.5 inch) to the proper level on the sight glass (if equipped).
4. Clean the cooling system filler cap. Inspect the gasket that is on the cooling system filler cap. If the gasket that is on the cooling system filler cap is damaged, discard the old cooling system filler cap and install a new cooling system filler cap. If the gasket that is on the cooling system filler cap is not damaged, use a 9S-8140 Pressurizing Pump in order to pressure test the cooling system filler cap. The correct pressure for the cooling system filler cap is stamped on the face of the cooling system filler cap. If the cooling system filler cap does not retain the correct pressure, install a new cooling system filler cap.
5. Start the engine. Inspect the cooling system for leaks and for proper operating temperature.

i02482066

Cooling System Coolant Extender (ELC) - Add

SMCS Code: 1352-544-NL

Cat ELC (Extended Life Coolant) does not require the frequent additions of any supplemental cooling additives which are associated with the present conventional coolants. The Cat ELC Extender only needs to be added once.

NOTICE

Use only Cat Extended Life Coolant (ELC) Extender with Cat ELC.

Do NOT use conventional supplemental coolant additive (SCA) with Cat ELC. Mixing Cat ELC with conventional coolants and/or conventional SCA reduces the Cat ELC service life.

Check the cooling system only when the engine is stopped and cool.

WARNING

Personal injury can result from hot coolant, steam and alkali.

At operating temperature, engine coolant is hot and under pressure. The radiator and all lines to heaters or the engine contain hot coolant or steam. Any contact can cause severe burns.

Remove cooling system pressure cap slowly to relieve pressure only when engine is stopped and cooling system pressure cap is cool enough to touch with your bare hand.

Do not attempt to tighten hose connections when the coolant is hot, the hose can come off causing burns.

Cooling System Coolant Additive contains alkali. Avoid contact with skin and eyes.

NOTICE

Care must be taken to ensure that fluids are contained during performance of inspection, maintenance, testing, adjusting and repair of the product. Be prepared to collect the fluid with suitable containers before opening any compartment or disassembling any component containing fluids.

Refer to Special Publication, NENG2500, "Caterpillar Dealer Service Tool Catalog" for tools and supplies suitable to collect and contain fluids on Caterpillar products.

Dispose of all fluids according to local regulations and mandates.

1. Loosen the cooling system filler cap slowly in order to relieve pressure. Remove the cooling system filler cap.
2. It may be necessary to drain enough coolant from the cooling system in order to add the Cat ELC Extender.
3. Add Cat ELC Extender according to the requirements for your engine's cooling system capacity. Refer to the Operation and Maintenance Manual, "Refill Capacities and Recommendations" article for more information.
4. Clean the cooling system filler cap. Inspect the gaskets on the cooling system filler cap. Replace the cooling system filler cap if the gaskets are damaged. Install the cooling system filler cap.

i01197583

Cooling System Coolant Level - Check

SMCS Code: 1350-535-FLV

Check the coolant level when the engine is stopped and cool.

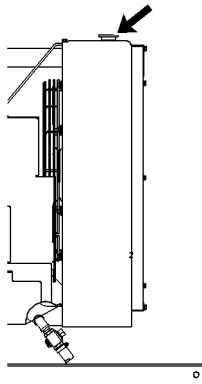

Illustration 56

g00285520

Cooling system filler cap

WARNING

Pressurized System: Hot coolant can cause serious burns. To open the cooling system filler cap, stop the engine and wait until the cooling system components are cool. Loosen the cooling system pressure cap slowly in order to relieve the pressure.

1. Remove the cooling system filler cap slowly in order to relieve pressure.
2. Maintain the coolant level within 13 mm (0.5 inch) of the bottom of the filler pipe. If the engine is equipped with a sight glass, maintain the coolant level to the proper level in the sight glass.

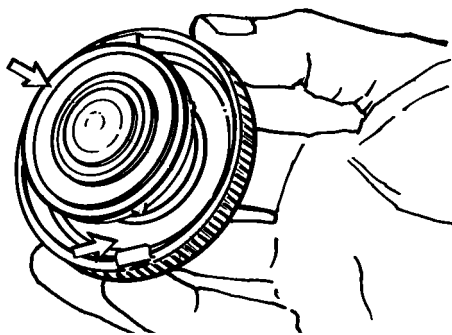

Illustration 57

g00103639

Typical filler cap gaskets

3. Clean the cooling system filler cap and check the condition of the filler cap gaskets. Replace the cooling system filler cap if the filler cap gaskets are damaged. Reinstall the cooling system filler cap.
4. Inspect the cooling system for leaks.

i02837191

Cooling System Coolant Sample (Level 1) - Obtain

SMCS Code: 1350-008; 1395-008; 1395-554; 7542

Note: Obtaining a Coolant Sample (Level 1) is optional if the cooling system is filled with Cat ELC (Extended Life Coolant). Cooling systems that are filled with Cat ELC should have a Coolant Sample (Level 2) that is obtained at the recommended interval that is stated in the Maintenance Interval Schedule.

Note: Obtain a Coolant Sample (Level 1) if the cooling system is filled with any other coolant instead of Cat ELC. This includes the following types of coolants:

- Commercial long life coolants that meet the Caterpillar Engine Coolant Specification -1 (Caterpillar EC-1)
- Cat DEAC (Diesel Engine Antifreeze/Coolant)
- Commercial heavy-duty coolant/antifreeze

Table 10

Recommended Interval		
Type of Coolant	Level 1	Level 2
Cat DEAC	Every 250 Hours ⁽¹⁾	Yearly ⁽¹⁾⁽²⁾
Cat ELC	Optional ⁽²⁾	Yearly ⁽²⁾

⁽¹⁾ This is the recommended interval for coolant samples for all conventional heavy-duty coolant/antifreeze. This is also the recommended interval for coolant samples of commercial coolants that meet the Cat EC-1 specification for engine coolant.

⁽²⁾ The Level 2 Coolant Analysis should be performed sooner if a problem is suspected or identified.

NOTICE

Always use a designated pump for oil sampling, and use a separate designated pump for coolant sampling. Using the same pump for both types of samples may contaminate the samples that are being drawn. This contaminate may cause a false analysis and an incorrect interpretation that could lead to concerns by both dealers and customers.

Note: Level 1 results may indicate a need for Level 2 Analysis.

Obtain the sample of the coolant as close as possible to the recommended sampling interval. In order to receive the full effect of S·O·S analysis, you must establish a consistent trend of data. In order to establish a pertinent history of data, perform consistent samplings that are evenly spaced. Supplies for collecting samples can be obtained from your Caterpillar dealer.

Use the following guidelines for proper sampling of the coolant:

- Complete the information on the label for the sampling bottle before you begin to take the samples.
- Keep the unused sampling bottles stored in plastic bags.
- Obtain coolant samples directly from the coolant sample port. You should not obtain the samples from any other location.
- Keep the lids on empty sampling bottles until you are ready to collect the sample.
- Place the sample in the mailing tube immediately after obtaining the sample in order to avoid contamination.
- Never collect samples from expansion bottles.
- Never collect samples from the drain for a system.

Submit the sample for Level 1 analysis.

For additional information about coolant analysis, see this Operation and Maintenance Manual, "Refill Capacities and Recommendations" or consult your Caterpillar dealer.

Cooling System Coolant Sample (Level 2) - Obtain

i01987714

SMCS Code: 1350-008; 1395-008; 1395-554; 7542

NOTICE

Always use a designated pump for oil sampling, and use a separate designated pump for coolant sampling. Using the same pump for both types of samples may contaminate the samples that are being drawn. This contaminate may cause a false analysis and an incorrect interpretation that could lead to concerns by both dealers and customers.

Refer to Operation and Maintenance Manual, "Cooling System Coolant Sample (Level 1) - Obtain" for the guidelines for proper sampling of the coolant.

Submit the sample for Level 2 analysis.

For additional information about coolant analysis, see Special Publication, SEBU6251, "Caterpillar Commercial Diesel Engines Fluids Recommendations" or consult your Caterpillar dealer.

i02839449

Cooling System Supplemental Coolant Additive (SCA) - Test/Add

SMCS Code: 1352-045; 1395-081

WARNING

Cooling system coolant additive contains alkali. To help prevent personal injury, avoid contact with the skin and eyes. Do not drink cooling system coolant additive.

NOTICE

Excessive supplemental coolant additive concentration can form deposits on the higher temperature surfaces of the cooling system, reducing the engine's heat transfer characteristics. Reduced heat transfer could cause cracking of the cylinder head and other high temperature components.

Excessive supplemental coolant additive concentration could also result in blockage of the heat exchanger, overheating, and/or accelerated wear of the water pump seal.

Do not exceed the recommended amount of supplemental coolant additive concentration.

NOTICE

Care must be taken to ensure that fluids are contained during performance of inspection, maintenance, testing, adjusting and repair of the product. Be prepared to collect the fluid with suitable containers before opening any compartment or disassembling any component containing fluids.

Refer to Special Publication, NENG2500, "Caterpillar Dealer Service Tool Catalog" and to Special Publication, GECJ0003, "Cat Shop Supplies and Tools" for tools and supplies suitable to collect and contain fluids on Caterpillar products.

Dispose of all fluids according to applicable regulations and mandates.

Note: Caterpillar recommends an S·O·S coolant analysis (Level 1).

Cooling Systems that Use Conventional Coolant

This maintenance procedure is required for conventional coolants such as DEAC. **This maintenance is NOT required for cooling systems that are filled with Extended Life Coolant.**

Test the Concentration of the SCA

NOTICE

Do not exceed the recommended six percent supplemental coolant additive concentration.

Test the concentration of the SCA with the 8T-5296 Coolant Conditioner Test Kit.

Add the SCA, If Necessary

WARNING

Pressurized System: Hot coolant can cause serious burns. To open the cooling system filler cap, stop the engine and wait until the cooling system components are cool. Loosen the cooling system pressure cap slowly in order to relieve the pressure.

1. Remove the cooling system filler cap slowly.
2. If necessary, drain some coolant in order to allow space for the addition of the SCA.
3. Add the proper amount of SCA. For the proper amount of SCA, refer to this Operation and Maintenance Manual, "Refill Capacities and Recommendations" topic. The proper concentration of SCA depends on the type of coolant that is used. For the proper concentration of SCA, refer to Special Publication, SEBU6251, "Caterpillar Commercial Diesel Engine Fluids Recommendations".
4. Clean the cooling system filler cap. Install the cooling system filler cap.

Cooling Systems that Use Water and SCA

Test the Concentration of the SCA

Test the concentration of the SCA with a 298-5311 Coolant Nitrite Test Kit for SCA or perform an S·O·S Coolant Analysis. The test kit includes the following items: a tool for the testing, 30 ampoules for testing nitrite, instructions, and a case. 294-7420 Test Kit contains the refill ampoules for the 298-5311 Coolant Nitrite Test Kit. Use the instructions that are included with the test kit in order to properly conduct the testing.

Refer to this Operation and Maintenance Manual, "Maintenance Interval Schedule" for the times at which the procedures should be conducted. Test the concentration of the SCA more frequently if more frequent testing is indicated by the results of the S·O·S Coolant Analysis.

NOTICE

Do not exceed the recommended eight percent supplemental coolant additive concentration.

Add the SCA, If Necessary

WARNING

Pressurized System: Hot coolant can cause serious burns. To open the cooling system filler cap, stop the engine and wait until the cooling system components are cool. Loosen the cooling system pressure cap slowly in order to relieve the pressure.

1. Remove the cooling system filler cap slowly.
2. If necessary, drain some coolant in order to allow space for the addition of the SCA.
3. Add the proper amount of SCA. For the proper amount of SCA, refer to this Operation and Maintenance Manual, "Refill Capacities and Recommendations" topic. For the proper concentration of SCA, refer to Special Publication, SEBU6251, "Caterpillar Commercial Diesel Engine Fluids Recommendations".
4. Clean the cooling system filler cap. Install the cooling system filler cap.

i02623972

Cooling System Water Temperature Regulator - Replace

SMCS Code: 1355-510

Replace the water temperature regulator before the water temperature regulator fails. This is a recommended preventive maintenance practice. Replacing the water temperature regulator reduces the chances for unscheduled downtime.

A water temperature regulator that fails in a partially opened position can cause overheating or overcooling of the engine.

A water temperature regulator that fails in the closed position can cause excessive overheating. Excessive overheating could result in cracking of the cylinder head or piston seizure problems.

A water temperature regulator that fails in the open position will cause the engine operating temperature to be too low during partial load operation. Low engine operating temperatures during partial loads could cause an excessive carbon buildup inside the cylinders. This excessive carbon buildup could result in an accelerated wear of the piston rings and wear of the cylinder liner.

NOTICE

Failure to replace your water temperature regulator on a regularly scheduled basis could cause severe engine damage.

Caterpillar engines incorporate a shunt design cooling system and require operating the engine with a water temperature regulator installed.

If the water temperature regulator is installed incorrectly, the engine may overheat, causing cylinder head damage. Ensure that the new water temperature regulator is installed in the original position. Ensure that the water temperature regulator vent hole is open.

Do not use liquid gasket material on the gasket or cylinder head surface.

Refer to two articles in the Disassembly and Assembly Manual, "Water Temperature Regulators - Remove and Water Temperature Regulators - Install" for the replacement procedure of the water temperature regulator, or consult your Caterpillar dealer.

Note: If only the water temperature regulators are replaced, drain the coolant from the cooling system to a level that is below the water temperature regulator housing.

i02933380

Crankshaft Vibration Damper - Inspect

SMCS Code: 1205-040

Damage to the crankshaft vibration damper or failure of the crankshaft vibration damper can increase torsional vibrations. This can result in damage to the crankshaft and to other engine components. A damper that is damaged can cause excessive gear train noise at variable points in the speed range.

The damper is mounted to the crankshaft which is located behind the belt guard on the front of the engine.

Visconic Damper

The visconic damper has a weight that is located inside a fluid filled case. The weight moves in the case in order to limit torsional vibration.

Inspect the damper for evidence of fluid leaks. If a fluid leak is found, determine the type of fluid. The fluid in the damper is silicone. Silicone has the following characteristics: transparent, viscous, smooth, and adhering.

If the fluid leak is oil, inspect the crankshaft seals for leaks. If a leak is observed, replace the crankshaft seals.

Inspect the damper and repair or replace the damper for any of the following reasons:

- The damper is dented, cracked, or leaking.
- The paint on the damper is discolored from heat.
- The engine has had a failure because of a broken crankshaft.
- Analysis of the oil has revealed that the front main bearing is badly worn.
- There is a large amount of gear train wear that is not caused by a lack of oil.

Refer to the Disassembly and Assembly Manual, "Vibration Damper and Pulley - Remove and Install" or consult your Caterpillar dealer for information about damper replacement.

i01217164

Electrical Connections - Check

SMCS Code: 4459-535

Check all exposed electrical connections for tightness.

Check the following devices for loose mounting or physical damage:

- transformers
- fuses
- capacitors
- lightning arrestors

Check all lead wires and electrical connections for proper clearance.

i01664717

Engine - Clean

SMCS Code: 1000-070

WARNING

Personal injury or death can result from high voltage.

Moisture could create paths of electrical conductivity.

Make sure the unit is off line (disconnected from utility and/or other generators), locked out and tagged "Do Not Operate".

NOTICE

Water or condensation can cause damage to generator components. Protect all electrical components from exposure to water.

NOTICE

Accumulated grease and oil on an engine is a fire hazard. Keep the engine clean. Remove debris and fluid spills whenever a significant quantity accumulates on the engine.

Steam cleaning the engine will remove accumulated oil and grease. A clean engine provides the following benefits:

- Easy detection of fluid leaks
- Maximum heat transfer characteristics

- Ease of maintenance

Note: For more information on cleaning and drying electric generators, refer to Special Instruction, SEHS9124, "Cleaning and Drying of Electric Set Generators".

i02353651

Engine Air Cleaner Element (Dual Element) - Clean/Replace (If Equipped)

SMCS Code: 1051; 1054-037

See this Operation and Maintenance Manual, "Engine Air Cleaner Element - Clean/Replace" for information on servicing the primary air filter.

Inspecting and Replacing the Secondary Air Cleaner Element (If Equipped)

NOTICE

Never run the engine without an air cleaner element installed. Never run the engine with a damaged air cleaner element. Do not use air cleaner elements with damaged pleats, gaskets or seals. Dirt entering the engine causes premature wear and damage to engine components. Air cleaner elements help to prevent air-borne debris from entering the air inlet.

NOTICE

Never service the air cleaner element with the engine running since this will allow dirt to enter the engine.

Operating conditions (dust, dirt, and debris) may require more frequent service of the air cleaner element. If the air cleaner element becomes plugged, the air can split the material of the air cleaner element. Unfiltered air will drastically accelerate internal engine wear. Your Caterpillar dealer has the proper air cleaner elements for your application. Consult your Caterpillar dealer for the correct air cleaner element.

The secondary air cleaner element is not serviceable or washable. The secondary air cleaner element should be removed and discarded for every three cleanings of the primary air cleaner element.

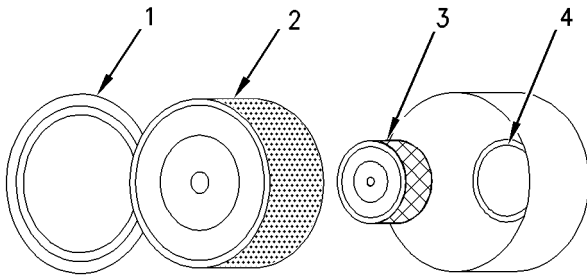

Illustration 58

g00736431

- (1) Cover
(2) Primary air cleaner element
(3) Secondary air cleaner element
(4) Air inlet for the turbocharger

1. Remove the cover. Remove the primary air cleaner element.
2. Cover the air inlet for the turbocharger with adhesive material in order to keep dirt out of the turbocharger.
3. Clean the inside of the air cleaner cover and body with a clean, dry cloth.
4. Remove the adhesive covering that covers the air inlet for the turbocharger. Install the secondary air cleaner element. Install a primary air cleaner element that is new or clean.
5. Install the air cleaner cover.
6. Reset the air cleaner service indicator.

i01900118

Engine Air Cleaner Service Indicator - Inspect (If Equipped)

SMCS Code: 7452-040

Some engines may be equipped with a different service indicator.

Some engines are equipped with a differential gauge for inlet air pressure. The differential gauge for inlet air pressure displays the difference in the pressure that is measured before the air cleaner element and the pressure that is measured after the air cleaner element. As the air cleaner element becomes dirty, the pressure differential rises. If your engine is equipped with a different type of service indicator, follow the OEM recommendations in order to service the air cleaner service indicator.

The service indicator may be mounted on the air cleaner housing or in a remote location.

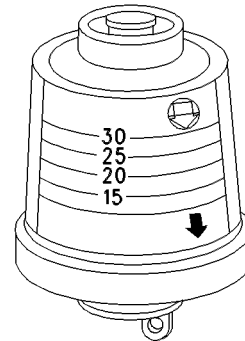

Illustration 59

g00103777

Typical service indicator

Observe the service indicator. The air cleaner element should be cleaned or the air cleaner element should be replaced when one of the following conditions occur:

- The yellow diaphragm enters the red zone.
- The red piston locks in the visible position.

Test the Service Indicator

Service indicators are important instruments.

- Check for ease of resetting. The service indicator should reset in less than three pushes.
- Check the movement of the yellow core when the engine is accelerated to the engine rated speed. The yellow core should latch approximately at the greatest vacuum that is attained.

If the service indicator does not reset easily, or if the yellow core does not latch at the greatest vacuum, the service indicator should be replaced. If the new service indicator will not reset, the hole for the service indicator may be plugged.

The service indicator may need to be replaced frequently in environments that are severely dusty, if necessary. Replace the service indicator annually regardless of the operating conditions. Replace the service indicator when the engine is overhauled, and whenever major engine components are replaced.

Note: When a new service indicator is installed, excessive force may crack the top of the service indicator. Tighten the service indicator to a torque of 2 N·m (18 lb in).

i02327200

i01786814

Engine Crankcase Breather - Clean

SMCS Code: 1317-070

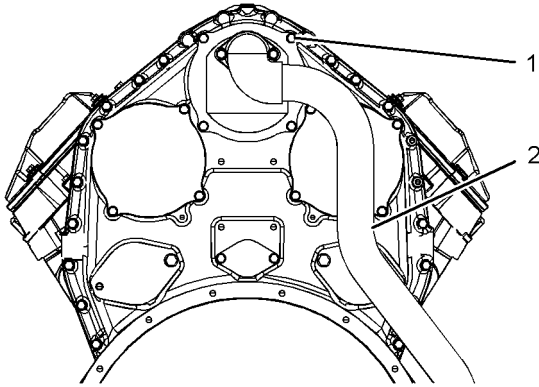

Illustration 60

g01162493

The crankcase breather is located on the back of the engine.

1. Remove the tube (2) from the outlet of the breather and loosen the clamp.
2. Remove the bolts (1) and remove the breather from the engine.
3. Check the condition of the seal. Replace the seal if the seal is damaged.
4. Remove the breather element. Wash the breather element and wash the breather in a clean nonflammable solvent.
5. Shake the breather element until the breather element is dry. You may also use pressurized air in order to dry the breather element.
6. Check the condition of the tube. Replace the tube if the tube is damaged.
7. Install the element into the breather and install the breather.
8. Install the tube onto the outlet of the breather cover and tighten the clamp.

Engine Mounts - Check

SMCS Code: 1152-535

Misalignment of the engine and the driven equipment will cause extensive damage. Excessive vibration can lead to misalignment. Excessive vibration of the engine and the driven equipment can be caused by the following conditions:

- Improper mounting
- Loose bolts
- Deterioration of the isolators

Ensure that the mounting bolts are tightened to the proper torque. For standard torques, see Specifications, SENR3130, "Torque Specifications".

Ensure that the isolators are free of oil and contamination. Inspect the isolators for deterioration. Ensure that the bolts for the isolators are tightened to the proper torque.

Replace any isolator that shows deterioration. For more information, see the literature that is provided by the OEM of the isolators. Also see the Application and Installation Guide for the engine. Consult your Caterpillar dealer for assistance.

i02108396

Engine Oil Level - Check

SMCS Code: 1348-535-FLV

WARNING

Hot oil and hot components can cause personal injury. Do not allow hot oil or hot components to contact the skin.

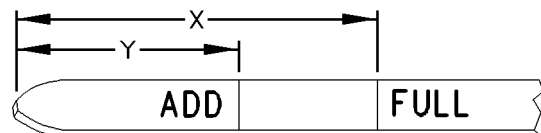

Illustration 61

g00110310

(Y) "ADD" mark
(X) "FULL" mark

NOTICE

Perform this maintenance with the engine stopped.

1. Maintain the oil level between “ADD” mark (Y) and “FULL” mark (X) on the oil level gauge. Do not fill the crankcase above “FULL” mark (X).

NOTICE

Engine damage can occur if the crankcase is filled above the “FULL” mark on the oil level gauge (dipstick).

An overfull crankcase can enable the crankshaft to dip into the oil. This will reduce the power that is developed and also force air bubbles into the oil. These bubbles (foam) can cause the following problems: reduction of the oil’s ability to lubricate, reduction of oil pressure, inadequate cooling of the pistons, oil blowing out of the crankcase breathers, and excessive oil consumption.

Excessive oil consumption will enable deposits to form on the pistons and in the combustion chamber. Deposits in the combustion chamber lead to the following problems: guttering of the valves, packing of carbon under the piston rings, and wear of the cylinder liner.

If the oil level is above the “FULL” mark on the oil level gauge, drain some of the oil immediately.

2. Remove the oil filler cap and add oil, if necessary. For the correct oil to use, see this Operation and Maintenance Manual, “Refill Capacities and Recommendations” topic (Maintenance Section). Do not fill the crankcase above “FULL” mark (X) on the oil level gauge. Clean the oil filler cap. Install the oil filler cap.
3. Record the amount of oil that is added. For the next oil sample and analysis, include the total amount of oil that has been added since the previous sample. This will help to provide the most accurate oil analysis.

i01935337

Engine Oil Sample - Obtain

SMCS Code: 1348-554-SM

In addition to a good preventive maintenance program, Caterpillar recommends using S·O·S oil analysis at regularly scheduled intervals in order to monitor the condition of the engine and the maintenance requirements of the engine. S·O·S oil analysis provides infrared analysis, which is required for determining nitration and oxidation levels.

Obtain the Sample and the Analysis

 **WARNING**

Hot oil and hot components can cause personal injury. Do not allow hot oil or hot components to contact the skin.

Before you take the oil sample, complete the Label, PEEP5031 for identification of the sample. In order to help obtain the most accurate analysis, provide the following information:

- Engine model
- Service hours on the engine
- The number of hours that have accumulated since the last oil change
- The amount of oil that has been added since the last oil change

To ensure that the sample is representative of the oil in the crankcase, obtain a warm, well mixed oil sample.

To avoid contamination of the oil samples, the tools and the supplies that are used for obtaining oil samples must be clean.

Caterpillar recommends using the sampling valve in order to obtain oil samples. The quality and the consistency of the samples are better when the sampling valve is used. The location of the sampling valve allows oil that is flowing under pressure to be obtained during normal engine operation.

The 169-8373 Fluid Sampling Bottle is recommended for use with the sampling valve. The fluid sampling bottle includes the parts that are needed for obtaining oil samples. Instructions are also provided.

NOTICE

Always use a designated pump for oil sampling, and use a separate designated pump for coolant sampling. Using the same pump for both types of samples may contaminate the samples that are being drawn. This contaminate may cause a false analysis and an incorrect interpretation that could lead to concerns by both dealers and customers.

If the engine is not equipped with a sampling valve, use the 1U-5718 Vacuum Pump. The pump is designed to accept sampling bottles. Disposable tubing must be attached to the pump for insertion into the sump.

For instructions, see Special Publication, PEHP6001, "How To Take A Good Oil Sample". Consult your Caterpillar dealer for complete information and assistance in establishing an S-O-S program for your engine.

i02107152

Engine Oil and Filter - Change

SMCS Code: 1318-510

WARNING

Hot oil and hot components can cause personal injury. Do not allow hot oil or hot components to contact the skin.

Do not drain the oil when the engine is cold. As the oil cools, suspended waste particles settle on the bottom of the oil pan. The waste particles are not removed with the draining cold oil. Drain the crankcase with the engine stopped. Drain the crankcase with the oil warm. This draining method allows the waste particles that are suspended in the oil to be drained properly.

Failure to follow this recommended procedure will cause the waste particles to be recirculated through the engine lubrication system with the new oil.

Drain the Engine Oil

After the engine has been run at the normal operating temperature, stop the engine. Use one of the following methods to drain the engine crankcase oil:

- If the engine is equipped with a drain valve, turn the drain valve knob counterclockwise in order to drain the oil. After the oil has drained, turn the drain valve knob clockwise in order to close the drain valve.
- If the engine is not equipped with a drain valve, remove the oil drain plug in order to allow the oil to drain. If the engine is equipped with a shallow sump, remove the bottom oil drain plugs from both ends of the oil pan.

After the oil has drained, the oil drain plugs should be cleaned and installed.

Replace the Oil Filter

NOTICE

Caterpillar oil filters are built to Caterpillar specifications. Use of an oil filter not recommended by Caterpillar could result in severe engine damage to the engine bearings, crankshaft, etc., as a result of the larger waste particles from unfiltered oil entering the engine lubricating system. Only use oil filters recommended by Caterpillar.

1. Remove the oil filter with a 1U-8760 Chain Wrench.
2. Cut the oil filter open with a 175-7546 Oil Filter Cutter Gp. Break apart the pleats and inspect the oil filter for metal debris. An excessive amount of metal debris in the oil filter may indicate early wear or a pending failure.

Use a magnet to differentiate between the ferrous metals and the nonferrous metals that are found in the oil filter element. Ferrous metals may indicate wear on the steel and cast iron parts of the engine.

Nonferrous metals may indicate wear on the aluminum parts, brass parts or bronze parts of the engine. Parts that may be affected include the following items: main bearings, rod bearings, turbocharger bearings, and cylinder heads.

Due to normal wear and friction, it is not uncommon to find small amounts of debris in the oil filter. Consult your Caterpillar dealer in order to arrange for a further analysis if an excessive amount of debris is found in the oil filter.

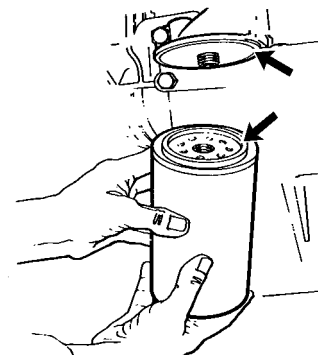

Illustration 62

g00103713

Typical filter mounting base and filter gasket

3. Clean the sealing surface of the filter mounting base. Ensure that all of the old oil filter gasket is removed.
4. Apply clean engine oil to the new oil filter gasket.

NOTICE

Do not fill the oil filters with oil before installing them. This oil would not be filtered and could be contaminated. Contaminated oil can cause accelerated wear to engine components.

5. Install the oil filter. Tighten the oil filter until the oil filter gasket contacts the base. Tighten the oil filter by hand according to the instructions that are shown on the oil filter. Do not overtighten the oil filter.

Fill the Engine Crankcase

1. Remove the oil filler cap. Refer to the Operation and Maintenance Manual, "Refill Capacities and Recommendations" for more information.
-

NOTICE

If equipped with an auxiliary oil filter system or a remote oil filter system, follow the OEM or filter manufacturer's recommendations. Under filling or overfilling the crankcase with oil can cause engine damage.

NOTICE

To prevent crankshaft bearing damage, crank the engine with the fuel OFF. This will fill the oil filters before starting the engine. Do not crank the engine for more than 30 seconds.

2. Start the engine and run the engine at "LOW IDLE" for two minutes. Perform this procedure in order to ensure that the lubrication system has oil and that the oil filters are filled. Inspect the oil filter for oil leaks.
3. Stop the engine and allow the oil to drain back to the sump for a minimum of ten minutes.
4. Remove the oil level gauge in order to check the oil level. Maintain the oil level between the "ADD" and "FULL" marks on the oil level gauge.

i00626013

Engine Protective Devices - Check

SMCS Code: 7400-535

Alarms and shutoffs must function properly. Alarms provide timely warning to the operator. Shutoffs help to prevent damage to the engine. It is impossible to determine if the engine protective devices are in good working order during normal operation. Malfunctions must be simulated in order to test the engine protective devices.

A calibration check of the engine protective devices will ensure that the alarms and shutoffs activate at the setpoints. Ensure that the engine protective devices are functioning properly.

NOTICE

During testing, abnormal operating conditions must be simulated.

The tests must be performed correctly in order to prevent possible damage to the engine.

To prevent damage to the engine, only authorized service personnel or your Caterpillar dealer should perform the tests.

Visual Inspection

Visually check the condition of all gauges, sensors and wiring. Look for wiring and components that are loose, broken, or damaged. Damaged wiring or components should be repaired or replaced immediately.

i02562758

Engine Valve Lash - Inspect/Adjust

SMCS Code: 1102-025

NOTICE

Only qualified service personnel should perform this maintenance. Refer to the Service Manual or your Caterpillar dealer for the complete valve lash adjustment procedure.

Operation of Caterpillar engines with improper valve adjustments can reduce engine efficiency. This reduced efficiency could result in excessive fuel usage and/or shortened engine component life.

The initial valve lash adjustment on new engines, rebuilt engines, or remanufactured engines should be performed at the first oil change. The initial valve lash adjustment on new engines, rebuilt engines, or remanufactured engines must be performed before the fourth oil change, or at the fourth oil change. The adjustment is necessary due to the initial wear of the valve train components and to the seating of the valve train components.

This maintenance is part of a lubrication and preventive maintenance schedule in order to help provide maximum engine life.

⚠ WARNING

Ensure that the engine can not be started while this maintenance is being performed. To help prevent possible injury, do not use the starting motor to turn the flywheel.

Hot engine components can cause burns. Allow additional time for the engine to cool before measuring/adjusting valve lash clearance.

To obtain an accurate measurement, allow the valves to cool before this maintenance is performed.

The following components should be inspected and adjusted when the valves are inspected and adjusted.

- Valve actuators
- Injectors
- Compression brakes

Refer to Systems Operation, Testing and Adjusting, "Engine Valve Lash - Inspect/Adjust" in your service manual for more information.

i02784507

Fan Drive Bearing - Lubricate

SMCS Code: 1359-086-BD

Some of the fan drives have grease fittings and some of the fan drives do not have grease fittings. If there is no grease fitting, periodic lubrication is not required. The fan drive requires grease only if the fan drive is equipped with a zerk.

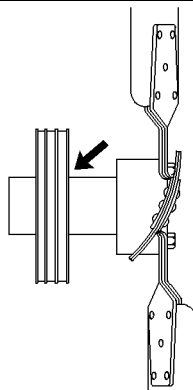

Illustration 63

g00746166

Typical location of the grease fitting (if equipped) that is for the fan drive bearing

The pulley is shown with the belt guards that have been removed.

Lubricate the grease fitting that is on the fan drive bearing with High Speed Ball Bearing Grease or the equivalent.

Inspect the fan drive pulley assembly for wear or for damage. If the shaft is loose, an inspection of the internal components should be performed. Refer to the Systems Operation Testing and Adjusting Manual for additional information.

i01565926

Fuel Injector - Inspect/Adjust

SMCS Code: 1290-025

Note: Perform this procedure when the engine valve lash is inspected.

NOTICE

The camshafts must be correctly timed with the crankshaft before an adjustment of the lash for the fuel injector is made. The timing pins must be removed from the camshafts before the crankshaft is turned or damage to the cylinder block will be the result.

Inspect the adjustment of the lash for the fuel injector according to the Testing And Adjusting, "Fuel Injector Adjustment". Adjust the lash for the fuel injector, if necessary.

i02879917

Fuel System - Prime

SMCS Code: 1250-548; 1258-548

⚠ WARNING

Fuel leaked or spilled onto hot surfaces or electrical components can cause a fire. To help prevent possible injury, turn the start switch off when changing fuel filters or water separator elements. Clean up fuel spills immediately.

The fuel system should be primed after a unit injector is changed or when the fuel system is totally dry.

Note: The fuel system does not typically need to be primed when the primary fuel filters or secondary fuel filters are changed or when an Electronic Control Module (ECM) is replaced. When the engine is started under these circumstances, the engine may momentarily run rough until the air is purged from the system.

NOTICE

Do not allow dirt to enter the fuel system. Thoroughly clean the area around a fuel system component that will be disconnected. Fit a suitable cover over any disconnected fuel system components.

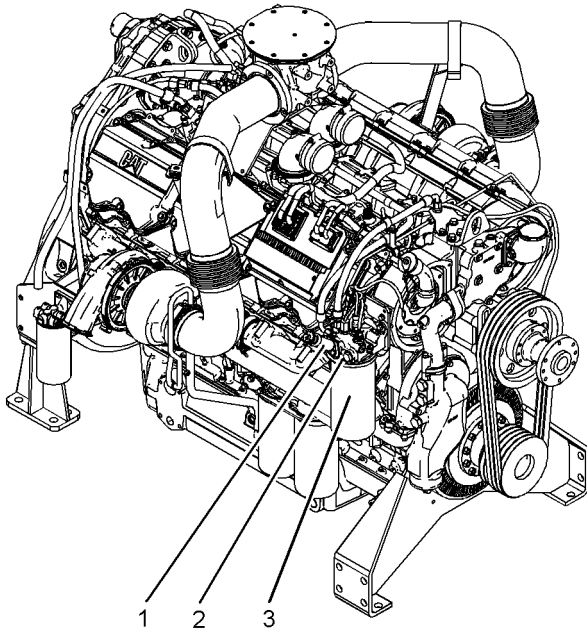

Illustration 64

g01275925

The right side view of a typical C27 or C32 Engine that is configured for a genset

- (1) Fuel priming pump
- (2) Fuel filter base
- (3) Secondary fuel filter

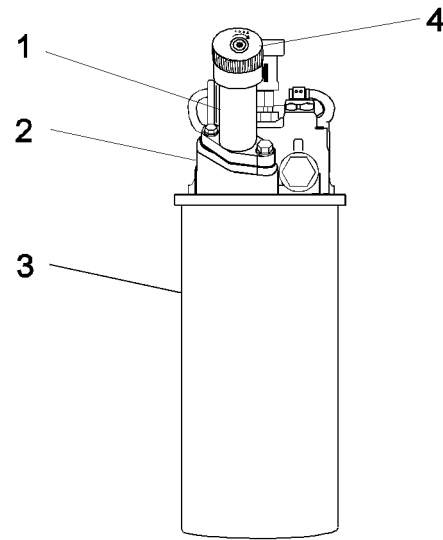

Illustration 65

g01275944

The secondary fuel filter and the fuel priming pump is shown.

- (1) Fuel priming pump
- (2) Fuel filter base
- (3) Secondary fuel filter
- (4) Priming pump plunger

Follow the procedure below in order to prime the engine with fuel.

1. Turn the priming pump plunger (4) counterclockwise in order to unlock the plunger. Manually pump the plunger in order to fill the fuel lines and the fuel filters with fuel.
2. As the air is purged from the fuel system, fuel pressure will increase. This will create resistance in the plunger. Continue to pump the plunger until a strong resistance is felt. The number of strokes will vary with the amount of air in the fuel lines.
3. After resistance is felt in the plunger, push in the plunger. Lock the plunger by turning the plunger clockwise.
4. Start the engine at low idle.
5. If the engine runs rough, continue to run the engine at low idle until the engine runs smoothly.

NOTICE

Do not crank the engine continuously for more than 30 seconds. Allow the starting motor to cool for two minutes before cranking the engine again.

i02049797

Fuel System Primary Filter (Water Separator) Element - Replace

SMCS Code: 1260-510-FQ; 1263-510-FQ

Water in the fuel can cause the engine to run rough. Water in the fuel may cause an electronic unit injector to fail. If the fuel has been contaminated with water, the element should be changed before the regularly scheduled interval.

The primary filter/water separator also provides filtration in order to help extend the life of the secondary fuel filter. The element should be changed regularly. Install a vacuum gauge. Change the element for the primary filter/water separator if the pressure is at 50 to 70 kPa (15 to 20 inches Hg).

Replace the Element

WARNING

Fuel leaked or spilled onto hot surfaces or electrical components can cause a fire. To help prevent possible injury, turn the start switch off when changing fuel filters or water separator elements. Clean up fuel spills immediately.

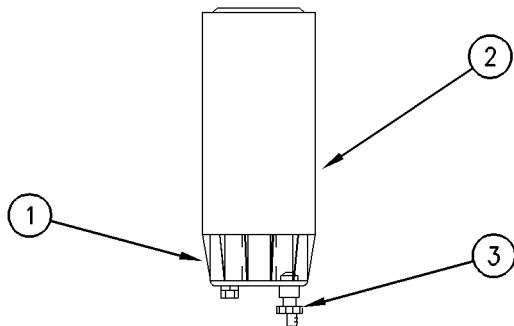

Illustration 66

g00668636

- (1) Bowl
- (2) Element
- (3) Drain

1. Stop the engine.
2. Turn the start switch to the "OFF" position.
3. Shut off the fuel tank supply valve to the engine.
4. If the primary fuel filter is equipped with a drain valve (3), open the drain valve in order to drain any fuel from the filter case. Close the drain valve (3).

NOTICE

Use a suitable container to catch any fuel that might spill. Clean up any spilled fuel immediately.

5. Remove the fuel filter bowl (1) and wash the fuel filter bowl with clean diesel fuel.
6. Remove the fuel filter (2).
7. Clean the gasket sealing surface of the fuel filter base. Ensure that all of the old gasket is removed.
8. Apply clean diesel fuel to the new fuel filter gasket.

NOTICE

In order to maximize fuel system life and prevent premature wear out from abrasive particles in the fuel, use Caterpillar fuel filters.

Consult your Caterpillar dealer for proper part numbers.

9. Install the new fuel filter (2). Spin the fuel filter onto the fuel filter base until the gasket contacts the base. Use the rotation index marks on the filters as a guide for proper tightening. Tighten the filter for an additional 3/4 turn by hand. Do not overtighten the filter.

NOTICE

Do not fill the fuel filters with fuel before installing them. The fuel would not be filtered and could be contaminated. Contaminated fuel will cause accelerated wear to fuel system parts.

10. Install the clean fuel filter bowl (1) on the new fuel filter.

NOTICE

The water separator is under suction during normal engine operation. Ensure that the vent plug is tightened securely to help prevent air from entering the fuel system.

11. Open the fuel tank supply valve.
12. Start the engine and check for leaks. Run the engine for one minute. Stop the engine and check the engine for leaks again.

Detection of leaks is very difficult especially if the engine is running. The primary filter/water separator is under suction. A leak will allow air to enter the fuel. The air in the fuel can cause low power due to aeration of the fuel. If air enters the fuel, check the components for overtightening or undertightening.

i01463757

Fuel System Primary Filter/Water Separator - Drain

SMCS Code: 1260-543; 1263-543

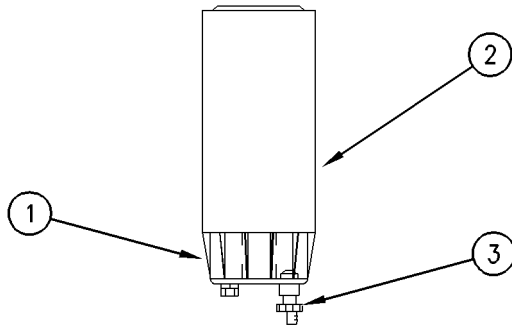

Illustration 67

g00668636

- (1) Bowl
- (2) Element
- (3) Drain

Bowl (1) should be monitored daily for signs of water. If water is present, drain the water from the bowl.

1. Open drain (3). The drain is a self-ventilated drain. Catch the draining water in a suitable container. Dispose of the water properly.
2. Close drain (3).

NOTICE

The water separator is under suction during normal engine operation. Ensure that the drain valve is tightened securely to help prevent air from entering the fuel system.

i02326422

Fuel System Secondary Filter - Replace

SMCS Code: 1261-510-SE

WARNING

Fuel leaked or spilled onto hot surfaces or electrical components can cause a fire. To help prevent possible injury, turn the start switch off when changing fuel filters or water separator elements. Clean up fuel spills immediately.

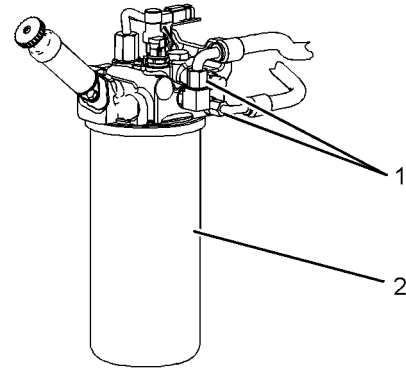

Illustration 68

g01162207

- (1) Fuel supply connections
- (2) Fuel filter

NOTICE

Do not allow dirt to enter the fuel system. Thoroughly clean the area around a fuel system component that will be disconnected. Fit a suitable cover over any disconnected fuel system components.

NOTICE

Use a suitable container to catch any fuel that might spill. Clean up any spilled fuel immediately.

1. It may be necessary to relieve residual fuel pressure from the fuel system before removing the fuel filter.

Loosen one of the fuel supply connections (1) in order to purge any residual pressure.

NOTICE

Do not loosen fuel lines or fittings at the fuel manifold or ECM. The engine components may be damaged.

2. Remove the used fuel filter.
3. Clean the gasket sealing surface of the fuel filter base. Ensure that all of the old gasket is removed.
4. Apply clean diesel fuel to the new fuel filter gasket.

NOTICE

Do not fill the secondary fuel filter with fuel before installing. The fuel would not be filtered and could be contaminated. Contaminated fuel will cause accelerated wear to fuel system parts.

5. Install the new fuel filter. Spin the fuel filter onto the fuel filter base until the gasket contacts the base. Use the rotation index marks on the filters as a guide for proper tightening. Tighten the filter for an additional 3/4 turn by hand. Do not overtighten the filter.

i03071053

Fuel Tank Water and Sediment - Drain

SMCS Code: 1273-543-M&S

NOTICE

Care must be taken to ensure that fluids are contained during performance of inspection, maintenance, testing, adjusting and repair of the product. Be prepared to collect the fluid with suitable containers before opening any compartment or disassembling any component containing fluids.

Refer to Special Publication, NENG2500, "Caterpillar Dealer Service Tool Catalog" or refer to Special Publication, PECJ0003, "Caterpillar Shop Supplies and Tools Catalog" for tools and supplies suitable to collect and contain fluids on Caterpillar products.

Dispose of all fluids according to local regulations and mandates.

Fuel Tank

Fuel quality is critical to the performance and to the service life of the engine. Water in the fuel can cause excessive wear to the fuel system. Condensation occurs during the heating and cooling of fuel. The condensation occurs as the fuel passes through the fuel system and the fuel returns to the fuel tank. This causes water to accumulate in fuel tanks. Draining the fuel tank regularly and obtaining fuel from reliable sources can help to eliminate water in the fuel.

Drain the Water and the Sediment

Fuel tanks should contain some provision for draining water and draining sediment from the bottom of the fuel tanks.

Open the drain valve on the bottom of the fuel tank in order to drain the water and the sediment. Close the drain valve.

Check the fuel daily. Drain the water and sediment from the fuel tank after operating the engine or drain the water and sediment from the fuel tank after the fuel tank has been filled. Allow five to ten minutes before performing this procedure.

Fill the fuel tank after operating the engine in order to drive out moist air. This will help prevent condensation. Do not fill the tank to the top. The fuel expands as the fuel gets warm. The tank may overflow.

Some fuel tanks use supply pipes that allow water and sediment to settle below the end of the fuel supply pipe. Some fuel tanks use supply lines that take fuel directly from the bottom of the tank. If the engine is equipped with this system, regular maintenance of the fuel system filter is important.

Fuel Storage Tanks

Drain the water and the sediment from the fuel storage tank during the following conditions:

- Weekly
- Oil change
- Refill of the tank

This will help prevent water or sediment from being pumped from the storage tank into the engine fuel tank. A four micron(c) absolute filter for the breather vent on the fuel tank is also recommended. Refer to Special Publication, SENR9620, "Improving Fuel System Durability".

If a bulk storage tank has been refilled or moved recently, allow adequate time for the sediment to settle before filling the engine fuel tank. Internal baffles in the bulk storage tank will also help trap sediment. Filtering fuel that is pumped from the storage tank helps to ensure the quality of the fuel. When possible, water separators should be used.

i02290310

Generator - Dry

SMCS Code: 4450-569

NOTICE

Do not operate the generator if the windings are wet. If the generator is operated when the windings are wet, damage can occur due to insulation breakdown.

When moisture is present or when moisture is suspected in a generator, the generator must be dried before being energized.

If the drying procedure does not restore the insulation resistance to an acceptable value, the winding should be reconditioned.

Note: For additional information, refer to Special Instruction, SEHS9124 .

Drying Methods

The following methods can be used for drying a generator:

- Self-circulating air method
- Oven method

NOTICE

Do not allow the winding temperature to exceed 85 °C (185.0 °F). Temperatures that are greater than 85 °C (185.0 °F) will damage the winding insulation.

Self-Circulating Air Method

Run the engine and disconnect the generator load. This will help circulate air. Operate the generator space heaters.

Oven Method

Place the entire generator inside a forced air drying oven for four hours at 65 °C (149 °F).

NOTICE

Use a forced air type oven rather than a radiant type oven.

Radiant type ovens can cause localized overheating.

i01461264

Generator - Inspect

SMCS Code: 4450-040

WARNING

Personal injury or death can result from improper troubleshooting and repair procedures.

The following troubleshooting and repair procedures should only be performed by qualified personnel familiar with this equipment.

Refer to Safety Section, "Generator Isolating for Maintenance" for information regarding the procedure to safely isolate the generator.

Proper maintenance of electrical equipment requires periodic visual examination of the generator and periodic visual examination of the windings. Proper maintenance of electrical equipment also requires appropriate electrical checks and appropriate thermal checks. Insulation material should be examined for cracks. The insulation material should be examined for accumulations of dirt and dust. If there is an insulation resistance value that is below normal, a conductive path may be present. This conductive path may be made of one of the following materials:

- Carbon
- Salt
- Metal dust
- Dirt that is saturated with moisture

These contaminants will develop a conductive path which may produce shorts. Cleaning is advisable if heavy accumulations of dirt can be seen or if heavy accumulations of dust can be seen. If excess dirt is the cause of a restriction in the ventilation, cleaning is also advisable. Restricted ventilation will cause excessive heating.

NOTICE

To avoid the possibility of deterioration to the generator windings, do not clean the generator unless there is visual, electrical, or thermal evidence that dirt is present.

If harmful dirt accumulations are present, a variety of cleaning techniques are available. The cleaning procedure that is used may be determined by one of the items on the following list:

- The extent of the cleaning procedure that is being attempted
- The type of enclosure of the generator
- The voltage rating of the generator
- The type of dirt that is being removed

Cleaning (Assembled Generators)

Cleaning may be required at the point of installation. At this point, complete disassembly of the generator may not be necessary or feasible. In this case, a vacuum cleaner should be used to pick up the following items: dry dirt, dust, and carbon. This will prevent the spreading of these contaminants.

i01473721

A small nonconductive tube may need to be connected to the vacuum cleaner. This will allow the vacuum cleaner to clean the surfaces that are not exposed. After most of the dust has been removed, a small brush may be attached to the vacuum hose in order to loosen dirt that is more firmly attached to the surface.

After the initial cleaning with a vacuum, compressed air may be used to remove the remaining dust and dirt. Compressed air that is used for cleaning should be free of moisture and free of oil. Air pressure should be a maximum of 210 kPa (30 psi) in order to prevent mechanical damage to the insulation. If the above cleaning procedures are not effective, consult a Caterpillar dealer.

Cleaning (Disassembled Generators)

An initial insulation resistance check should be made on the generator in order to confirm electrical integrity. A minimum reading of one megohm would be expected with severely contaminated generators. A zero megohm reading may indicate an insulation breakdown. An insulation breakdown requires more than cleaning. An insulation breakdown requires repair.

A high pressure wash is normally an effective way to clean windings. This includes windings that have been exposed to flooding or windings that have been contaminated by salt. A solution of hot water and detergent is used for this method of cleaning.

A high pressure wash sprays a high velocity fluid stream of this solution over the generator that is being cleaned. This detergent washing is followed by multiple sprays of clean water. The clean water is used in order to remove the detergent or the clean water is used in order to dilute the detergent.

Allow the generator to dry at room temperature. Check the insulation resistance. The insulation resistance should now be normal. If the insulation resistance is not normal, repeat the procedure. It may be necessary to use solvents if the generator is contaminated with oil or if the generator is contaminated with grease.

Note: For more information on drying methods, refer to Special Instructions, SEHS9124, "Cleaning and Drying of Electric Set Generators".

Generator Load - Check

SMCS Code: 4450-535-LA

During normal operation, monitor the power factor and monitor generator loading.

When a generator is installed or when a generator is reconnected, ensure that the total current in any one phase does not exceed the nameplate rating. Each phase should carry the same load. This allows the generator to work at the rated capacity. If one phase current exceeds the nameplate amperage, an electrical imbalance will occur. An electrical imbalance can result in an electrical overload and an electrical imbalance can result in overheating.

The power factor can be referred to as the efficiency of the load. This can be expressed as the ratio of kVA to actual kW. The power factor can be calculated by dividing kW by kVA. Power factor is expressed as a decimal. Power factor is used to mean the portion of current that is supplied to a system that is doing useful work. The portion of the current that is not doing useful work is absorbed in maintaining the magnetic field in motors. This current (reactive load) can be maintained without engine power.

Electric sets normally have a low idle setting that is higher than industrial engines. Low idle will be approximately 66 percent of the full speed that is achieved by 60 Hz units. This would be equal to 80 percent of the full speed that is achieved by 50 Hz units.

Some electric sets are equipped with Woodward governors and some electric sets are equipped with Caterpillar electronic governors. These electric sets have no low idle stop. On electric sets with mechanical governors and natural gas electric sets, the low idle is set at the factory. Adjustment of the low idle on these machines should only be done by a Caterpillar dealer.

Note: Operating the electric set at low idle speed for an extended time will cause some voltage regulators to shut off. The electric set must be completely shut down and the electric set must be restarted. This will allow the voltage regulator to again produce an output.

i01473730

Generator Set - Test

SMCS Code: 4450-081

WARNING

Personal injury or death can result from high voltage.

When power generation equipment must be in operation to make tests and/or adjustments, high voltage and current are present.

Improper test equipment can fail and present a high voltage shock hazard to its user.

Make sure the testing equipment is designed for and correctly operated for high voltage and current tests being made.

When servicing or repairing electric power generation equipment:

- **Make sure the unit is off-line (disconnected from utility and/or other generators power service), and either locked out or tagged DO NOT OPERATE.**
- **Make sure the generator engine is stopped.**
- **Make sure all batteries are disconnected.**
- **Make sure all capacitors are discharged.**

Table 11

Tools Needed		
Part Number	Part	Quantity
6V-7070	Digital Multimeter	1
	12 VDC battery	1
	Potential Transformer	1

The generator set functional test is a simplified test that can be performed in order to determine if the generator is functional. The generator set functional test should be performed on a generator set that is under load.

The generator set functional test determines if the following statements happen:

- A phase voltage is being generated.
- The phase voltages are balanced.

- The phase voltages change relative to engine speed.

The generator set functional test consists of the following steps:

1. Stop the generator. Connect the potential transformer's high voltage winding to the generator terminals (T1) and (T2). Connect the voltmeter to the low voltage winding. If two transformers are available, connect the high voltage winding of the second transformer to the generator terminals (T1) and (T3). Connect the secondary terminals that correspond to generator terminal (T2) of both transformers together.
2. Disconnect wires "F1+" and "F2-" from the voltage regulator. Disconnect the generator from the load.
3. Connect a 12 VDC automotive battery to wires "F1+" and "F2-".

NOTICE

Do not operate the generator set at a speed that is higher than one-half of the rated speed.

Higher speeds under these test conditions can cause damage to the system.

4. Operate the generator set at half the rated speed.
5. Measure the AC voltage across the low voltage terminals of the transformer that correspond to the following generator terminals: "T1" and "T2", "T2" and "T3", and "T3" and "T1". Record the voltages.
6. Monitor the voltage between any two of the locations in step 5. Decrease the generator set speed by 10 percent. Increase the generator set speed by 10 percent.
7. The voltages that were measured in Step 5 should be nearly equal. These voltages should measure a minimum of 85 VAC.
8. When the generator set speed is decreased by 10 percent, the voltages that were measured in Step 6 should decrease by 10 percent. When the generator set speed is increased by 10 percent, the voltages that were measured in Step 6 should increase by 10 percent.

i02211917

Generator Set Vibration - Inspect

SMCS Code: 4450-040-VI

Check for vibration damage. Vibration may cause the following problems:

- Loose fittings
- Loose belts
- Excessive noise
- Cracked insulation

The following areas are susceptible to vibration damage:

- Stator output leads
- Protective sleeving
- Insulation
- Exposed electrical connections
- Transformers
- Fuses
- Capacitors
- Lightning arresters

When a generator set is installed a vibration plot should be recorded in order to assist in diagnosing potential problems. This vibration plot should be updated yearly. The vibration plot should also be updated when the generator set is moved. Refer to Data Sheet, LEKQ4023, "Linear Vibration" for the allowable limits of vibration.

Contact the Caterpillar Dealer Service Tools group for information on ordering a vibration analyzer that will meet your needs.

i02574347

Heat Shield - Inspect/Replace

SMCS Code: 1067-040; 1067-510

NOTICE

Use caution when you inspect heat shields. Ensure that the engine is not running and ensure that the engine components are cool before you touch heat shields.

Visually inspect all heat shields for signs of wear. Some unacceptable signs of wear are listed below.

- Outer covering that is chafed or cracked
- Outer covering that is cut
- Outer covering that shows signs of abrasion
- Fasteners that are loose or missing
- Insulation material that is exposed

Replace all heat shields that show any signs of wear.

i02121526

Hoses and Clamps - Inspect/Replace

SMCS Code: 7554-040; 7554-510

Inspect all hoses for leaks that are caused by the following conditions:

- Cracking
- Softness
- Loose clamps

Replace hoses that are cracked or soft. Tighten any loose clamps.

NOTICE

Do not bend or strike high pressure lines. Do not install bent or damaged lines, tubes or hoses. Repair any loose or damaged fuel and oil lines, tubes and hoses. Leaks can cause fires. Inspect all lines, tubes and hoses carefully. Tighten all connections to the recommended torque.

Check for the following conditions:

- End fittings that are damaged or leaking
- Outer covering that is chafed or cut
- Exposed wire that is used for reinforcement
- Outer covering that is ballooning locally
- Flexible part of the hose that is kinked or crushed
- Armoring that is embedded in the outer covering

A constant torque hose clamp can be used in place of any standard hose clamp. Ensure that the constant torque hose clamp is the same size as the standard clamp.

Due to extreme temperature changes, the hose will heat set. Heat setting causes hose clamps to loosen. This can result in leaks. A constant torque hose clamp will help to prevent loose hose clamps.

Each installation application can be different. The differences depend on the following factors:

- Type of hose
- Type of fitting material
- Anticipated expansion and contraction of the hose
- Anticipated expansion and contraction of the fittings

Replace the Hoses and the Clamps

WARNING

Pressurized System: Hot coolant can cause serious burns. To open the cooling system filler cap, stop the engine and wait until the cooling system components are cool. Loosen the cooling system pressure cap slowly in order to relieve the pressure.

1. Stop the engine. Allow the engine to cool.
 2. Loosen the cooling system filler cap slowly in order to relieve any pressure. Remove the cooling system filler cap.
- Note:** Drain the coolant into a suitable, clean container. The coolant can be reused.
3. Drain the coolant from the cooling system to a level that is below the hose that is being replaced.
 4. Remove the hose clamps.
 5. Disconnect the old hose.
 6. Replace the old hose with a new hose.
 7. Install the hose clamps with a torque wrench.

Note: Refer to the Specifications, SENR3130, "Torque Specifications" in order to locate the proper torques.

8. Refill the cooling system.
9. Clean the cooling system filler cap. Inspect the cooling system filler cap's gaskets. Replace the cooling system filler cap if the gaskets are damaged. Install the cooling system filler cap.

10. Start the engine. Inspect the cooling system for leaks.

i01494696

Insulation - Test

SMCS Code: 4453-081; 4454-081; 4457-081; 4470-081

Recommended Periodic Insulation Tests

WARNING

The high voltage that is produced by an operating generator set can cause severe injury or death. Before performing any maintenance or repairs, ensure that the generator will not start.

Place the engine control switch in the "OFF" position. Attach "DO NOT OPERATE" tags to all starting controls. Disconnect the batteries or disable the starting system. Lock out all switchgear and automatic transfer switches that are associated with the generator.

Table 12

Tools Needed		
Part Number	Part Name	Quantity
142-5055	Insulation Testing Gp	1
9U-6003	Insulation Testing Gp	1

Periodically, use an insulation tester to check the insulation resistance of the generator's main stator winding. The frequency of this test is determined by the generator's environment. Previous insulation tester readings will also determine the frequency of this test.

Test the main stator windings with an insulation tester in the following situations:

- The generator set is started for the first time.
- The generator set is removed from storage.
- The generator set is operating in a humid environment. Test every three months.
- The generator set is not protected from the elements in an enclosed area. Test every three months.

- The generator set is installed in an enclosed area. This area needs to be low in humidity and this area needs to have steady temperatures. Test every twelve months (minimum).
- The generator set has not been run under load for three months. Test the generator set weekly. Use space heaters around the generator set if the generator is exposed to a sea water environment or if the humidity is above 75 percent. Also use space heaters if a test result was below 3 megohms.

Space heaters must be used whenever the generator set is not under load. Space heaters must also be used whenever salt is present or whenever high humidity is present. Using a space heater in this fashion is the only way to maintain insulation tester readings above one megohm. Use space heaters only when the generator is not running.

For additional information, refer to Special Instruction, SEHS9124, "Cleaning and Drying of Electric Set Generators".

Recommended Periodic Insulation Test Procedure

WARNING

Personal injury or death can result from electrocution.

The megohmmeter is applying a high voltage to the circuit.

To avoid electrocution, do not touch the instrument leads without first discharging them. When finished testing also discharge the generator windings.

1. Take the generator out of service.
2. Visually inspect the generator for moisture. If moisture exists, do not perform this insulation test. Dry the unit first. Refer to Special Instruction, SEHS9124, "Cleaning and Drying of Electric Set Generators".
3. Inspect the installation. Determine the equipment that will be tested by the insulation tester.
4. Discharge the capacitance of the windings.
5. Disconnect "T0" from ground.
6. Disconnect the regulator sensing lead wires: "20", "22", and "24".
7. Connect the insulation tester's RED lead to ground.

8. Connect the insulation tester's BLACK lead to "T0".
9. For units that are 600 volts or less, set the voltage to 500 Volts. For units that are more than 600 volts, set the voltage to 1000 Volts.
10. Use the 30/60 Time Resistance Method:
 - a. Apply voltage.
 - b. Observe the readings at 30 seconds. Observe the readings at 60 seconds.
 - c. Record the 60 second reading. This reading must be corrected for temperature.
 - d. Record temperature.
 - e. Record humidity.
 - f. Remove voltage.
11. Evaluate the readings. The actual value of the resistance may vary greatly between generators. For this reason, the insulation's condition must be evaluated. Base this evaluation on the comparison between the 60 second resistance readings and the readings that were taken on previous dates. These two readings must be taken under similar conditions. If a 60 second resistance reading has a 50 percent reduction from the previous reading, the insulation may have absorbed too much moisture.

Switch the insulation tester to the "OFF" position. This will discharge the insulation tester's leads. Disconnect the insulation tester's leads.

Note: The results from the insulation resistance checks indicate when cleaning and/or repairing is becoming critical. Generally, insulation resistance will vary greatly with temperature. Therefore, always test at the same temperature and humidity. Refer to Illustration 69.

Engine Serial Number _____

Generator Serial Number _____

Approx. Insulation Resistance Variation
with Temperature (IEEE 43-1974)

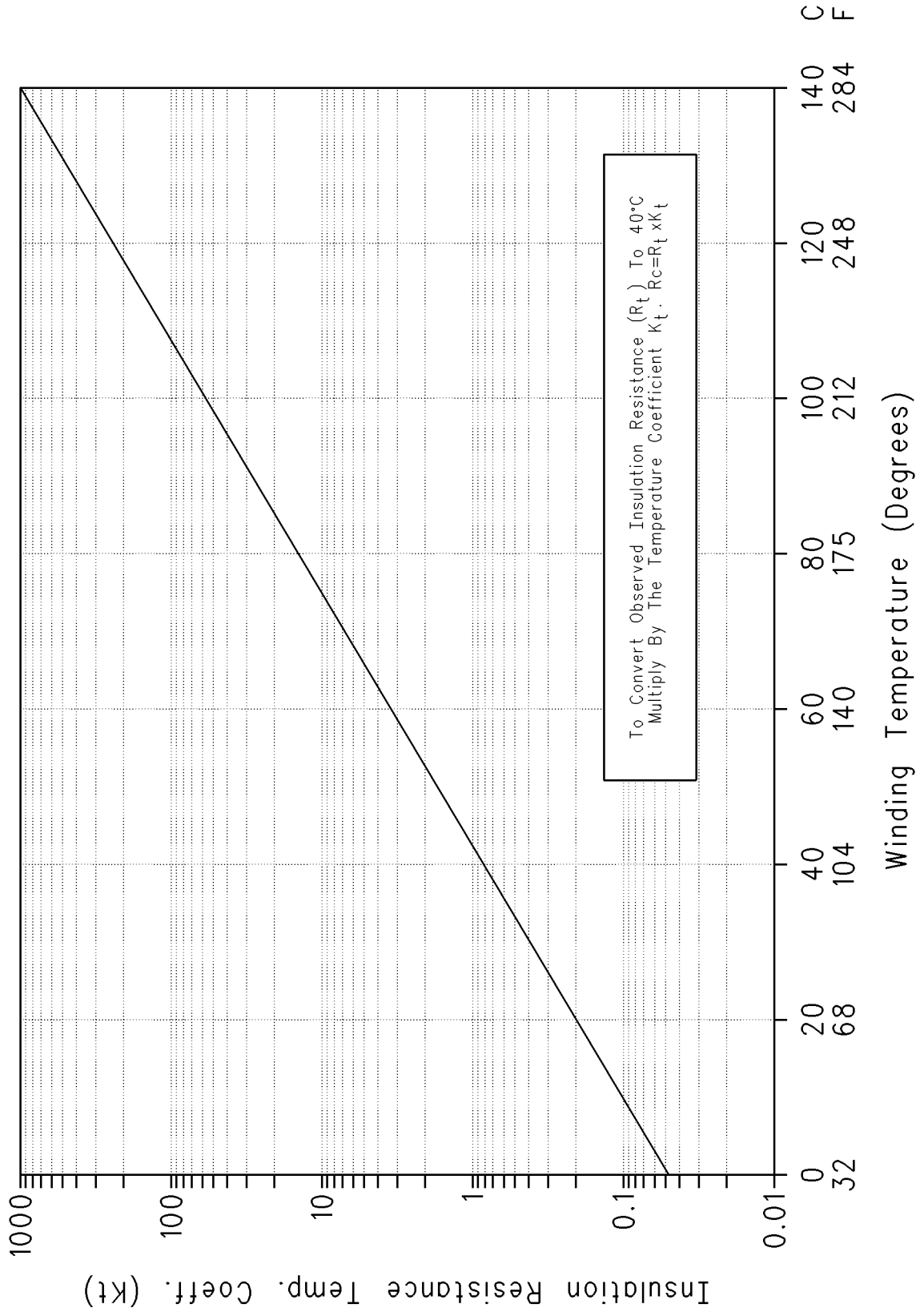

i01917546

Jacket Water Heater - Check (Standby Generator Sets (If Equipped))

SMCS Code: 1383-535

Jacket water heaters help to improve startability in ambient temperatures that are below 21 °C (70 °F). All installations that require automatic starting should have jacket water heaters.

Check the operation of the jacket water heater. For an ambient temperature of 0 °C (32 °F), the heater should maintain the jacket water coolant temperature at approximately 32 °C (90 °F).

i03257588

Overhaul Considerations

SMCS Code: 7595-043

Reduced hours of operation at full load will result in a lower average power demand. A decreased average power demand should increase both the engine service life and the overhaul interval.

The need for an overhaul is generally indicated by increased fuel consumption and by reduced power.

The following factors are important when a decision is being made on the proper time for an engine overhaul:

- The need for preventive maintenance
- The quality of the fuel that is being used
- The operating conditions
- The results of the S·O·S analysis

Oil Consumption as an Overhaul Indicator

Oil consumption, fuel consumption, and maintenance information can be used to estimate the total operating cost for your Caterpillar engine. Oil consumption can also be used to estimate the required capacity of a makeup oil tank that is suitable for the maintenance intervals.

Oil consumption is in proportion to the percentage of the rated engine load. As the percentage of the engine load is increased, the amount of oil that is consumed per hour also increases.

The oil consumption rate (brake specific oil consumption) is measured in grams per kW/h (lb per bhp). The brake specific oil consumption (BSOC) depends on the engine load. Consult your Caterpillar dealer for assistance in determining the typical oil consumption rate for your engine.

When an engine's oil consumption has risen to three times the original oil consumption rate due to normal wear, an engine overhaul should be scheduled. There may be a corresponding increase in blowby and a slight increase in fuel consumption.

Overhaul Options

Using Fuel Consumption For Calculating the Overhaul Intervals

Experience has shown that maintenance intervals are most accurately based on fuel consumption. Fuel consumption corresponds more accurately to the engine load. Table 13 and 14 lists average ranges of fuel consumption for a load factor of approximately 60 percent.

Table 13

Service Hours and Fuel Consumption for C27 Generator Set ⁽¹⁾	
Top End Overhaul	7500 Service Hours
	804399 L (212500 US gal)
Major Overhaul	15000 Service Hours
	1608799 L (425000 US gal)

⁽¹⁾ Fuel consumption is based on a load factor of approximately 60 percent.

Table 14

Service Hours and Fuel Consumption for C32 Generator set ⁽¹⁾	
Top End Overhaul	7500 Service Hours
	946360 L (250000 US gal)
Major Overhaul	15000 Service Hours
	1892700 L (500000 US gal)

⁽¹⁾ Fuel consumption is based on a load factor of approximately 60 percent.

Table 15

Equation For Calculating Overhaul Intervals	
$F/R = H$	
"F" is the estimated total amount of fuel consumption of the engine.	
"R" is the rate of fuel consumption in liters per hour or gallons per hour.	
"H" is the number of estimated hours until the overhaul interval.	

Use the actual records of fuel consumption, when possible. If the actual records are not available, use the following procedure in order to estimate the fuel consumption.

1. Estimate the average percent of the load for the operation of the engine.
2. Refer to the data for fuel consumption in the Technical Marketing Information (TMI) for your engine. This will determine the fuel consumption for the percent of the load that was estimated in Step 1. Use this figure as variable "F" for the equation in Table 15. For more information about the Technical Marketing Information (TMI) for your engine, consult your Caterpillar dealer.

Before Failure Overhaul

A planned overhaul before failure may be the best value for the following reasons:

- Costly unplanned downtime can be avoided.
- Many original parts can be reused according to the standards for reusable parts.
- The engine service life can be extended without the risk of a major catastrophe due to engine failure.
- The best cost/value relationship per hour of extended life can be attained.

After Failure Overhaul

If a major engine failure occurs and the engine must be removed, many options are available. An overhaul should be performed if the engine block or the crankshaft needs to be repaired.

If the engine block is repairable and/or the crankshaft is repairable, the overhaul cost should be between 40 percent and 50 percent of the cost of a new engine with a similar exchange core.

This lower cost can be attributed to three aspects:

- Specially designed Caterpillar engine features
- Caterpillar dealer exchange components
- Caterpillar Inc. remanufactured exchange components

Overhaul Recommendation

To minimize downtime, a scheduled engine overhaul by your Caterpillar dealer is recommended. This will provide you with the best cost/value relationship.

Note: Overhaul programs vary according to the engine application and according to the dealer that performs the overhaul. Consult your Caterpillar dealer for specific information about the available overhaul programs and about overhaul services for extending the engine life.

If an overhaul is performed without overhaul service from your Caterpillar dealer, be aware of the following maintenance recommendations.

Unit Fuel Injector

Clean the fuel injector body and replace the O-rings. Replace the O-rings and the gasket on the injector sleeve. Clean the area around the injector seating in the injector sleeve. Refer to the Service Manual for the complete procedure, or consult with your Caterpillar dealer for assistance.

Rebuild or Exchange

Cylinder Head Assembly, Connecting Rods, Pistons, Cylinder Liners, Turbocharger, Cylinder Packs, Oil Pump, and Fuel Transfer Pump

These components should be inspected according to the instructions that are found in various Caterpillar reusability publications. The Special Publication, SEBF8029 lists the reusability publications that are needed for inspecting the engine parts.

If the parts comply with the established inspection specifications that are expressed in the reusable parts guideline, the parts should be reused.

Parts that are not within the established inspection specifications should be dealt with in one of the following manners:

- Salvaging
- Repairing
- Replacing

Using out-of-spec parts can result in the following problems:

- Unscheduled downtime
- Costly repairs
- Damage to other engine parts
- Reduced engine efficiency
- Increased fuel consumption

Reduced engine efficiency and increased fuel consumption translates into higher operating costs. Therefore, Caterpillar Inc. recommends repairing out-of-spec parts or replacing out-of-spec parts.

Inspection and/or Replacement

Piston Rings, Crankshaft Bearings, Valve Rotators, and Crankshaft Seals

The following components may not last until the second overhaul.

- Thrust bearings
- Main bearings
- Rod bearings
- Valve rotators
- Crankshaft seals

Caterpillar Inc. recommends the installation of new parts at each overhaul period.

Inspect these parts while the engine is disassembled for an overhaul.

Inspect the crankshaft for any of the following conditions:

- Deflection
- Damage to the journals
- Bearing material that has seized to the journals

Check the journal taper and the profile of the crankshaft journals. Check these components by interpreting the wear patterns on the following components:

- Rod bearing
- Main bearings

Note: If the crankshaft is removed for any reason, use the magnetic particle inspection process to check for cracks in the crankshaft.

Inspect the camshaft for damage to the journals and to the lobes.

Note: If the camshaft is removed for any reason, use the magnetic particle inspection process to check for cracks in the camshaft.

Inspect the following components for signs of wear or for signs of scuffing:

- Camshaft bearings
- Camshaft followers

Caterpillar Inc. recommends replacing the crankshaft vibration damper.

Oil Cooler Core and Aftercooler Core

During an overhaul, the removal of the oil cooler core and the aftercooler core is recommended. The oil cooler core and the aftercooler core should be cleaned and pressure tested.

NOTICE

Do not use caustic cleaners to clean the core.

Caustic cleaners can attack the internal metals of the core and cause leakage.

Note: Use this cleaning procedure to clean the oil cooler core and the aftercooler core.

1. Remove the oil cooler core and the aftercooler core.
2. Remove any debris from the oil cooler core and the aftercooler core. To remove debris from the oil cooler core, turn the oil cooler core onto one end. To remove debris from the aftercooler core, turn the aftercooler core upside-down.
3. Flush the oil cooler core and the aftercooler core internally with cleaner in order to loosen foreign substances. This will also help to remove oil from the oil cooler core and the aftercooler core.

Note: The use of Hydrosolv Liquid Cleaners is recommended. Table 16 lists the Hydrosolv Liquid Cleaners that are available from your Caterpillar dealer.

Table 16

Hydrosolv Liquid Cleaners ⁽¹⁾		
Part Number	Description	Size
1U-5490	Hydrosolv 4165	19 L (5 US gallon)
174-6854	Hydrosolv 100	19 L (5 US gallon)

⁽¹⁾ Use a two to five percent concentration of the cleaner at temperatures up to 93°C (200°F). Refer to Application Guide, NEHS0526 or consult your Caterpillar dealer for more information.

4. Use steam to clean the oil cooler core and the aftercooler core. This removes any remaining residue from the cleaner. Flush the fins of the oil cooler core and the aftercooler core. Remove any other trapped debris.

5. Wash the oil cooler core and the aftercooler core with hot, soapy water. Rinse the oil cooler core and the aftercooler core thoroughly with clean water.

WARNING

Personal injury can result from air pressure.

Personal injury can result without following proper procedure. When using pressure air, wear a protective face shield and protective clothing.

Maximum air pressure at the nozzle must be less than 205 kPa (30 psi) for cleaning purposes.

6. Dry the oil cooler core and the aftercooler core with compressed air. Direct the air in the reverse direction of the normal flow.
7. Inspect the components in order to ensure cleanliness. The oil cooler core and the aftercooler core should be pressure tested. Repair the oil cooler core and the aftercooler core, if necessary. Install the oil cooler core and the aftercooler core.

For more information about cleaning the cores, consult your Caterpillar dealer.

Obtain Coolant Analysis

The concentration of supplemental coolant additive (SCA) should be checked regularly with test kits or with S·O·S Coolant Analysis (Level 1). Further coolant analysis is recommended when the engine is overhauled.

A coolant analysis can be conducted in order to verify the condition of the water that is being used in the cooling system. A full water analysis can be obtained by consulting your local water utility company or an agricultural agent. Private laboratories are also available for water analysis.

Caterpillar Inc. recommends an S·O·S Coolant Analysis (Level 2).

S·O·S Coolant Analysis (Level 2)

An S·O·S Coolant Analysis (Level 2) is a comprehensive coolant analysis which completely analyzes the coolant and the effects on the cooling system. An S·O·S Coolant Analysis (Level 2) provides the following information:

- Complete S·O·S Coolant Analysis (Level 2)
- Visual inspection of properties
- Identification of metal corrosion

- Identification of contaminants
- Identification of built up impurities (corrosion and scale)

S·O·S Coolant Analysis (Level 2) provides a report of the results of both the analysis and the maintenance recommendations.

For more information about coolant analysis, consult your Caterpillar dealer.

i01216962

Power Factor - Check

SMCS Code: 4450-535-PWR

The power factor of a system can be determined by a power factor meter or by calculations. The power factor can be calculated by dividing kW by kVA. Power factor is expressed as a decimal.

i02569617

Prelube Pump - Inspect

SMCS Code: 1319-040

Inspect the prelube pump for the following conditions:

- Cracks
- Pin holes
- Proper operation
- Wear

If repair or replacement is necessary, see the literature that is provided by the OEM of the pump. Consult your Caterpillar dealer for assistance.

i02559063

Radiator - Clean

SMCS Code: 1353-070

Note: Adjust the frequency of cleaning according to the effects of the operating environment.

Inspect the radiator for these items: damaged fins, corrosion, dirt, grease, insects, leaves, oil, and other debris. Clean the radiator, if necessary.

WARNING

Personal injury can result from air pressure.

Personal injury can result without following proper procedure. When using pressure air, wear a protective face shield and protective clothing.

The maximum air pressure for cleaning purposes must be reduced to 205 kPa (30 psi) when the air nozzle is deadheaded.

Pressurized air is the preferred method for removing loose debris. Direct the air in the opposite direction of the fan's air flow. Hold the nozzle approximately 6 mm (0.25 inch) away from the fins. Slowly move the air nozzle in a direction that is parallel with the tubes. This will remove debris that is between the tubes.

Pressurized water may also be used for cleaning. The maximum water pressure for cleaning purposes must be less than 275 kPa (40 psi). Use pressurized water in order to soften mud. Clean the core from both sides.

Use a degreaser and steam for removal of oil and grease. Clean both sides of the core. Wash the core with detergent and hot water. Thoroughly rinse the core with clean water.

After cleaning, start the engine and accelerate the engine to high idle rpm. This will help in the removal of debris and drying of the core. Stop the engine. Use a light bulb behind the core in order to inspect the core for cleanliness. Repeat the cleaning, if necessary.

Inspect the fins for damage. Bent fins may be opened with a "comb". Inspect these items for good condition: welds, mounting brackets, air lines, connections, clamps, and seals. Make repairs, if necessary.

For more detailed information on cleaning and inspection, refer to Special Publication, SEBD0518, "Know Your Cooling System".

i02246950

Rotating Rectifier - Check

SMCS Code: 4465-535

Check the exciter armature. Ensure that the rotating rectifier is tight. If a failure of a rectifier is suspected, proceed to the "Testing a Three-Diode Rectifier Block" section.

Testing a Three-Diode Rectifier Block

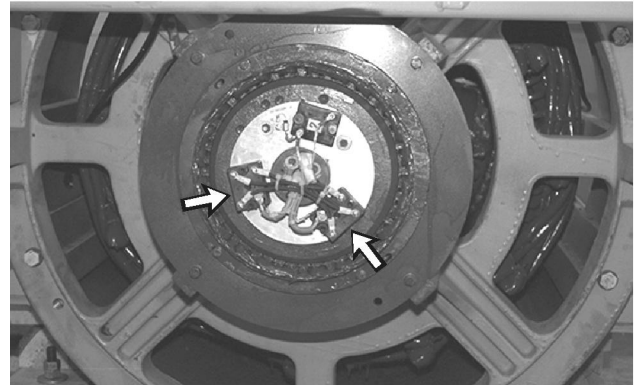

Illustration 70

g00610240

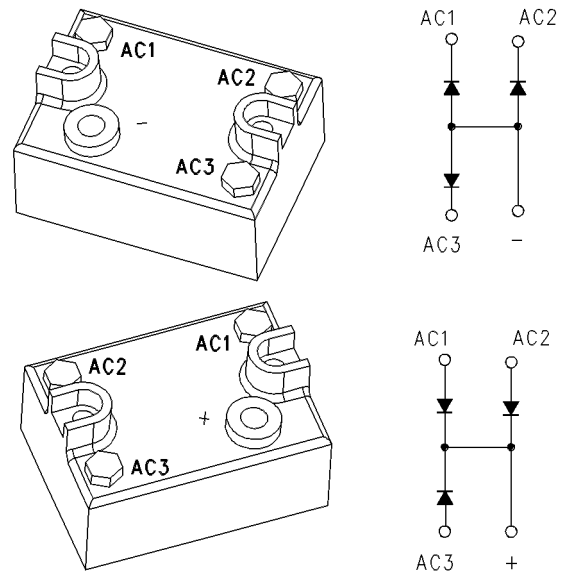

Illustration 71

g00613971

Three-Diode Rectifier Block (two pieces)

The following procedure tests all three diodes within a block. Check the positive rectifier block and the negative rectifier block. If any meter reading does not fall within the given ranges, replace the rectifier block.

1. Set the digital multimeter on the diode range. Remove all leads from the rectifier block.
2. To test the negative rectifier block, follow these steps:

- a. Place the red test lead on the negative “-” terminal. Place the black test lead on the following rectifier terminals: “AC1”(3), “AC2”(4), and “AC3”(5). All readings on the meter should be between 0.4 and 1.0.
 - b. Place the black test lead on the negative “-” terminal. Place the red test lead on the following rectifier terminals: “AC1”(3), “AC2”(4), and “AC3”(5). In all cases, the meter should read “OL” (overload).
3. To test the positive rectifier block, follow these steps:
- a. Place the red test lead on the positive “+” rectifier terminal. Place the black test lead on the following rectifier terminals: “AC1”(3), “AC2”(4), and “AC3”(5). In all cases, the meter should read “OL” (overload).
 - b. Place the black test lead on the positive “+” rectifier terminal. Place the red test lead on the following rectifier terminals: “AC1”(3), “AC2”(4), and “AC3”(5). All readings on the meter should be between 0.4 and 1.0.

Note: A shorted diode can cause damage to the exciter rotor. If a diode is shorted, check the exciter rotor. Refer to the Testing and Adjusting, “Winding - Test” and Testing and Adjusting, “Insulation - Test”. Perform these tests.

Note: This rectifier block also contains varistor “CR7”. “CR7” can be checked by measuring the resistance between the positive “+” rectifier terminal and the negative “-” rectifier terminal. The resistance should be a minimum of 15000.

i02985289

Space Heater - Check

SMCS Code: 4450-535-HTR

The space heater is attached to the rear bearing bracket. The space heater is located in the generator’s exciter end.

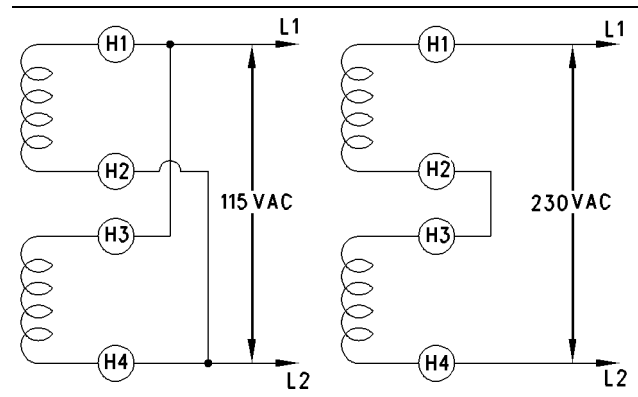

Illustration 72

Space Heater Connection Diagram

g00610396

An SR5 generator can operate in high humidity conditions without problems. The humidity can be as high as 100% non-condensing humidity. However, problems can occur when the generator is idle and the surrounding air is warmer than the generator. Moisture can form on the windings. Moisture will result in poor performance or even damage to the windings. Whenever the generator is not active, the optional space heaters should be operated.

An external source is required to operate the space heaters. Both of the sources must be a single phase. This source can be either 115 vac or 230 vac. When the external source is 50 hertz, 200 vac must be used. Refer to Illustration 72.

See your Caterpillar dealer for information on checking your Caterpillar generator.

i02627547

Speed Sensor - Clean/Inspect

SMCS Code: 1907-040; 1907-070

The C32 Generator Set has three different speed sensors.

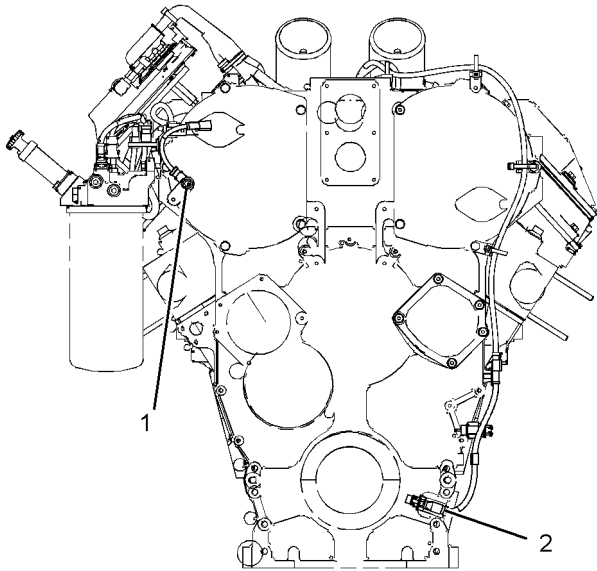

Illustration 73

g01184074

One speed/timing sensor (1) is mounted in the camshaft cover. A second speed/timing sensor (2) is mounted in the front housing. Both of these sensors are pulled into position by a bolt.

1. Remove the speed/timing sensors from the front housing. Check the condition of the plastic end of the speed/timing sensors for wear and/or contaminants.
2. Clean the metal shavings and other debris from the face of the speed/timing sensors. Use the procedure in the Service Manual in order to calibrate the speed/timing sensors.

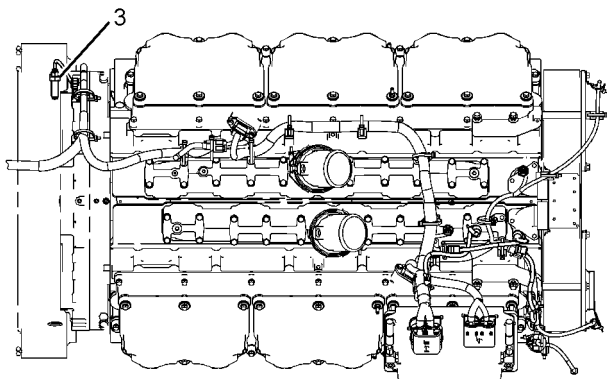

Illustration 74

g01184093

The third speed/timing sensor has a threaded end, and screws directly into the flywheel housing.

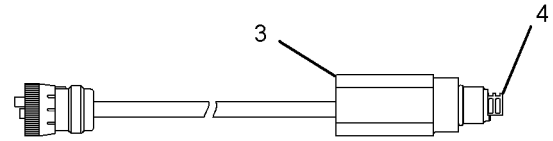

Illustration 75

g01184155

1. Remove the sensor. Inspect the condition of the end of the magnet. Look for signs of wear and contaminants.
2. Clean any debris from the face of the magnet.
3. Check the tension of the sliphead. Gently extend sliphead (4) for a minimum of 4 mm (0.16 inch). Then push back the sliphead.

When the sliphead has the correct tension, at least 22 N (5 lb) of force is required to push in the sliphead from the extended position.

NOTICE

The sliphead must be fully extended when the speed/timing sensor is installed so that the sensor maintains the correct clearance with the speed-timing wheel. If the correct clearance is not maintained, the signal from the sensor will not be generated.

Do not install the sensor between the teeth of the speed-timing wheel. Damage to the sensor would result. Before installing the sensor, ensure that a tooth of the wheel is visible in the mounting hole for the sensor.

4. Install the engine speed/timing sensor.
 - a. Ensure that a tooth on the speed-timing wheel is visible in the mounting hole for the sensor.
 - b. Extend sliphead (2) by a minimum of 4 mm (0.16 inch).
 - c. Coat the threads of the sensor with 4C-5597 Anti-Seize Compound.

Note: The sliphead is designed to contact a tooth during the first revolution of the speed-timing wheel. For the maximum allowable clearance between the sliphead and the tooth, refer to the engine's Specifications manual.

- d. Install the sensor. Tighten the sensor to 40 ± 5 N·m (30 ± 4 lb ft).

i03108463

Standby Generator Set Maintenance Recommendations

SMCS Code: 4450-041

A standby generator set may not need to be used very often. However, the generator set is usually needed for operation in an emergency situation. Maintenance of the standby generator set is very important for the following reasons:

- The generator set must always be in excellent operating condition.
- The generator set must be ready to work under load at any time.

Establishing a Preventive Maintenance Program will provide these benefits:

- Maximum availability of the standby generator set
- Longer service life for the generator set
- Minimum of expensive repairs

Your Caterpillar dealer can help you to establish an effective Preventive Maintenance Program for your generator set. Consult your Caterpillar dealer for details.

Maintenance and Operation Procedures

WARNING

The high voltage that is produced by an operating generator set can cause severe injury or death. Before performing any maintenance or repairs, ensure that the generator will not start.

Place the engine control switch in the “OFF” position. Attach “DO NOT OPERATE” tags to all starting controls. Disconnect the batteries or disable the starting system. Lock out all switchgear and automatic transfer switches that are associated with the generator.

The recommended maintenance for the generator set is listed in this Operation and Maintenance Manual, “Maintenance Interval Schedule (Standby Generator Sets)” (Maintenance Section).

Maintenance and Repair

The maintenance that is recommended for Every Week can be performed by an authorized operator. The maintenance that is recommended for the subsequent maintenance intervals must be performed by an authorized service technician or by your Caterpillar dealer.

Unless other instructions are provided, perform maintenance and repairs under the following conditions:

- The engine is stopped.
- The starting system is disabled.
- The generator does not pose an electrical shock hazard.
- The generator is disconnected from the load.

Operation

To ensure proper operation, the generator set must be exercised regularly. For instructions on operating the generator set, see the Operation and Maintenance Manual for the generator set control panel.

For these operation procedures, follow the instructions that are provided in this Operation and Maintenance Manual, “Operation Section”: starting the engine, engine operation, and stopping the engine.

Record Keeping

Maintain a record in order to document these items: gauge readings, maintenance that is performed, problems, and repairs.

Space Heaters

Moisture causes damage to generators and other electrical equipment. Make every effort to keep the generator set as dry as possible.

Generators can operate without problems in humid environments. However, problems can occur when the generator is inactive. Moisture can condense on the windings. This can result in poor performance. Also, damage to the windings can occur.

Use space heaters in order to help keep the windings dry. When the generator is not active, ensure that the space heaters are operating. When the generator is operating, turn OFF the space heaters.

i02618737

Starting Motor - Inspect (If equipped)

SMCS Code: 1451-040; 1453-040

Air Starting Motor

If the starting motor fails, the engine may not start in an emergency situation. A scheduled inspection of the starting motor is recommended.

The starting motor pinion and the flywheel ring gear must be in good condition in order for the engine to start properly. The engine will not start if the starting motor pinion does not engage the flywheel ring gear. The teeth of the starting motor pinion and the flywheel ring gear can be damaged because of irregular engagement.

Inspect the starting motor for proper operation. Listen for grinding when the engine is started. Inspect the teeth of the starting motor pinion and the flywheel ring gear. Look for patterns of wear on the teeth. Look for teeth that are broken or chipped. If damaged teeth are found, the starting motor pinion and the flywheel ring gear must be replaced.

WARNING

Personal injury or death can result from improperly checking for a leak.

Always use a board or cardboard when checking for a leak. Escaping air or fluid under pressure, even a pin-hole size leak, can penetrate body tissue causing serious injury, and possible death.

If fluid is injected into your skin, it must be treated immediately by a doctor familiar with this type of injury.

Inspect all of the components in the air circuit for the starting motor. Inspect all of the air lines and connections for leaks.

If damaged teeth are found, the air circuit for the starting motor must be examined in order to determine the cause of the problem.

Electric Starting Motor

If the starting motor fails, the engine may not start in an emergency situation. A scheduled inspection of the starting motor is recommended.

The starting motor pinion and the flywheel ring gear must be in good condition in order for the engine to start properly. The engine will not start if the starting motor pinion does not engage the flywheel ring gear. The teeth of the starting motor pinion and the flywheel ring gear can be damaged because of irregular engagement.

Inspect the starting motor for proper operation. Listen for grinding when the engine is started. Inspect the teeth of the starting motor pinion and the flywheel ring gear. Look for patterns of wear on the teeth. Look for teeth that are broken or chipped. If damaged teeth are found, the starting motor pinion and the flywheel ring gear must be replaced.

Problems with the electric starting motor can be caused by the following conditions: malfunction of the solenoid and malfunction of the electric starting system.

Inspect the electrical system for the following conditions:

- Loose connections
- Corrosion
- Wires that are worn or frayed
- Cleanliness

Removal and Installation of the Starting Motor

Refer to the Service Manual, "Disassembly and Assembly" module for information on removing the starting motor and installing the starting motor.

Consult your Caterpillar dealer for assistance and/or for options on replacement of the starting motor.

i01218172

Stator Lead - Check

SMCS Code: 4459-535

Visually inspect the following areas for cracking and physical damage:

- stator output leads
- protective sleeving
- insulation

i03086301

Stator Winding Temperature - Measure/Record

SMCS Code: 4453-082-TA

Some generators are equipped with optional 100 Ohm Resistance Temperature Detectors (RTD) that are mounted in slots of the main stator. When the generator set is equipped with RTD modules that are interfaced to an EMCP 3.2 or EMCP 3.3, the RTD modules can be interfaced in order to measure the temperature of the stator. Alternately, there are measuring devices in the open market that can be interfaced with the RTD. Caterpillar recommends the continuous monitoring of the RTD.

Refer to the specifications in table 17 for the maximum temperatures of the setpoints.

Table 17

Maximum Recommended Temperatures for the Setpoint ⁽¹⁾		
Generator set application	Alarm	Shutdown
Standby	180 °C (356 °F)	190 °C (374 °F)
Continuous	155 °C (311 °F)	165 °C (329 °F)

⁽¹⁾ If the trend of the operating temperature of the main stator is measured and the temperature is much lower than the recommended setpoints, adjust the alarm setpoint and the shutdown setpoint to a lower value in order to ensure that unusual temperature variances are recognized promptly.

i01539769

Turbocharger - Inspect

SMCS Code: 1052-040

Periodic inspection and cleaning is recommended for the turbocharger compressor housing (inlet side). Any fumes from the crankcase are filtered through the air inlet system. Therefore, by-products from oil and from combustion can collect in the turbocharger compressor housing. Over time, this buildup can contribute to loss of engine power, increased black smoke and overall loss of engine efficiency.

If the turbocharger fails during engine operation, damage to the turbocharger compressor wheel and/or to the engine may occur. Damage to the turbocharger compressor wheel can cause additional damage to the pistons, the valves, and the cylinder head.

NOTICE

Turbocharger bearing failures can cause large quantities of oil to enter the air inlet and exhaust systems. Loss of engine lubricant can result in serious engine damage.

Minor leakage of a turbocharger housing under extended low idle operation should not cause problems as long as a turbocharger bearing failure has not occurred.

When a turbocharger bearing failure is accompanied by a significant engine performance loss (exhaust smoke or engine rpm up at no load), do not continue engine operation until the turbocharger is repaired or replaced.

An inspection of the turbocharger can minimize unscheduled downtime. An inspection of the turbocharger can also reduce the chance for potential damage to other engine parts.

Note: Turbocharger components require precision clearances. The turbocharger cartridge must be balanced due to high rpm. Severe Service Applications can accelerate component wear. Severe Service Applications require more frequent inspections of the cartridge.

Removal and Installation

For options regarding the removal, installation, repair and replacement, consult your Caterpillar dealer. Refer to the Service Manual for this engine for the procedure and specifications.

Cleaning and Inspecting

1. Remove the exhaust outlet piping and remove the air inlet piping from the turbocharger. Visually inspect the piping for the presence of oil. Clean the interior of the pipes in order to prevent dirt from entering during reassembly.
2. Turn the compressor wheel and the turbine wheel by hand. The assembly should turn freely. Inspect the compressor wheel and the turbine wheel for contact with the turbocharger housing. There should not be any visible signs of contact between the turbine wheel or compressor wheel and the turbocharger housing. If there is any indication of contact between the rotating turbine wheel or the compressor wheel and the turbocharger housing, the turbocharger must be reconditioned.

i01494879

3. Check the compressor wheel for cleanliness. If only the blade side of the wheel is dirty, dirt and/or moisture is passing through the air filtering system. If oil is found only on the back side of the wheel, there is a possibility of a failed turbocharger oil seal.

The presence of oil may be the result of extended engine operation at low idle. The presence of oil may also be the result of a restriction of the line for the inlet air (plugged air filters), which causes the turbocharger to slobber.

4. Use a dial indicator to check the end clearance on the shaft. If the measured end play is greater than the Service Manual specifications, the turbocharger should be repaired or replaced. An end play measurement that is less than the minimum Service Manual specifications could indicate carbon buildup on the turbine wheel. The turbocharger should be disassembled for cleaning and for inspection if the measured end play is less than the minimum Service Manual specifications.
5. Inspect the bore of the turbine housing for corrosion.
6. Clean the turbocharger housing with standard shop solvents and a soft bristle brush.
7. Fasten the air inlet piping and the exhaust outlet piping to the turbocharger housing.

Varistor - Test

SMCS Code: 4466-081

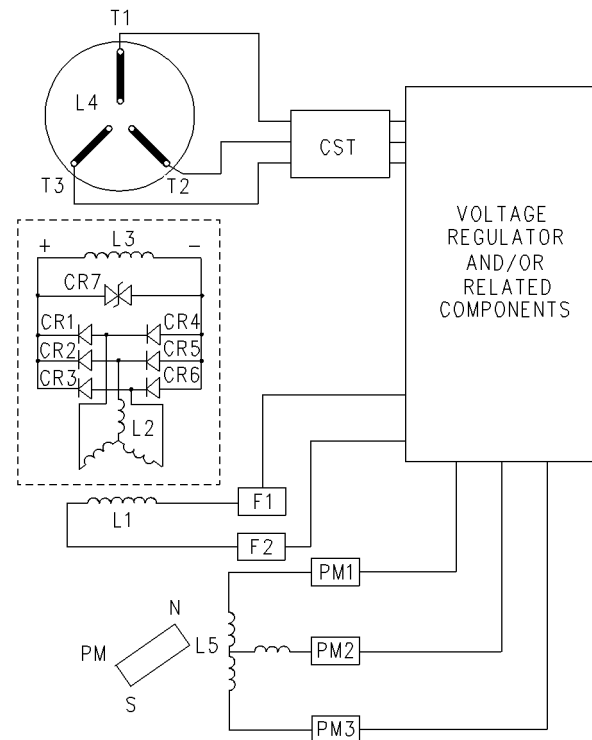

Illustration 76

g00677004

PMPE Generator Wiring Diagram

(CR1-CR6) Diodes
 (CR7) Varistor
 (L1) Exciter field (stator)
 (L2) Exciter armature (rotor)
 (L3) Main field (rotor)
 (L4) Main armature (stator)
 (L5) Pilot exciter armature
 (PM) Permanent magnet
 (RFA) Rotating field assembly
 (CST) Customer supplied transformer

Ohmmeter

An ohmmeter can be used to check a varistor (CR7). Place an ohmmeter across the varistor. The resistance should be a minimum of 15000 ohms. If the resistance is less than 15000 ohms, the varistor is faulty.

Test Light

i02591373

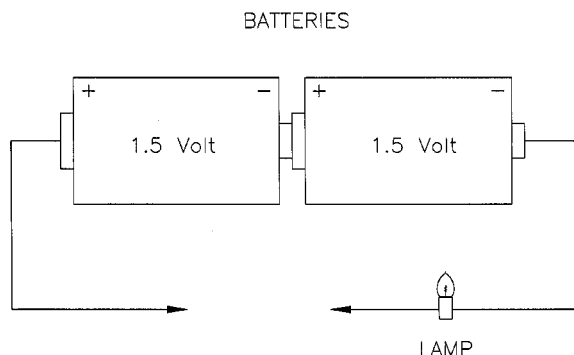

Illustration 77

g00555113

Test Light

Refer to the test light that is shown in Illustration 77. Follow these steps in order to test the varistor:

1. Disconnect either lead of the varistor (CR7).
2. Place the test light across the varistor.
3. Observe the results. The lamp should not light.
4. Reverse the test light.
5. Observe the results. The lamp should not light.

If the test light illuminates in either direction, there is a short in the varistor. Replace any faulty varistors with varistors that have comparable operating characteristics. Include the following information when a varistor is being ordered for replacement:

- Part number of the varistor
- Serial number of the generator

After the varistor has been replaced, verify that the strapping of the field winding lead is securely wound on the shaft. Also, verify that the strapping of the field winding lead is securely tied.

i01491868

Voltage and Frequency - Check

SMCS Code: 4450-535-EL

Check for the proper voltage setting and check for the proper frequency setting. Check for stability.

For the correct voltage and frequency, refer to the generator set's Serial Plate.

Walk-Around Inspection

SMCS Code: 1000-040

WARNING

Personal injury or death can result from improper troubleshooting and repair procedures.

The following troubleshooting and repair procedures should only be performed by qualified personnel familiar with this equipment.

Inspect the Engine for Leaks and for Loose Connections

A walk-around inspection should only take a few minutes. When the time is taken to perform these checks, costly repairs and accidents can be avoided.

For maximum engine service life, make a thorough inspection of the engine compartment before starting the engine. Look for items such as oil leaks or coolant leaks, loose bolts, worn belts, loose connections and trash buildup. Make repairs, as needed:

- The guards must be in the proper place. Repair damaged guards or replace missing guards.
- Wipe all caps and plugs before the engine is serviced in order to reduce the chance of system contamination.

NOTICE

For any type of leak (coolant, lube, or fuel) clean up the fluid. If leaking is observed, find the source and correct the leak. If leaking is suspected, check the fluid levels more often than recommended until the leak is found or fixed, or until the suspicion of a leak is proved to be unwarranted.

NOTICE

Accumulated grease and/or oil on an engine or deck is a fire hazard. Remove this debris with steam cleaning or high pressure water.

- Ensure that cooling lines are properly clamped. Check for leaks. Check the condition of all pipes.
- Inspect the water pump for coolant leaks.

Note: The water pump seal is lubricated by coolant in the cooling system. It is normal for a small amount of leakage to occur as the engine cools down and the parts contract.

Excessive coolant leakage may indicate the need to replace the water pump seal. For the removal of water pump and the installation of water pump and/or seals, refer to the Service Manual for the engine or consult your Caterpillar dealer.

- Inspect the lubrication system for leaks at the front crankshaft seal, the rear crankshaft seal, the oil pan, the oil filters and the valve cover.
- Inspect the Closed Crankcase Ventilation (CCV) filter, if equipped. If the restriction indicator is visible, service the CCV.
- Inspect the fuel system for leaks. Look for loose fuel line clamps.
- Inspect the piping for the air inlet system and the elbows for cracks and for loose clamps.
- Inspect the alternator belt and the accessory drive belts for cracks, breaks or other damage.

Belts for multiple groove pulleys must be replaced as matched sets. If only one belt is replaced, the belt will carry more load than the belts that are not replaced. The older belts are stretched. The additional load on the new belt could cause the belt to break.

- Drain the water and the sediment from fuel tanks on a daily basis in order to ensure that only clean fuel enters the fuel system.
- Inspect the wiring and the wiring harnesses for loose connections and for worn wires or frayed wires.
- Inspect the ground strap for a good connection and for good condition.
- Inspect the engine-to-frame ground strap for a good connection and for good condition.
- Disconnect any battery chargers that are not protected against the current drain of the starting motor. Check the condition and the electrolyte level of the batteries, unless the engine is equipped with a maintenance free battery.
- Check the condition of the gauges. Replace any gauges that are cracked. Replace any gauges that can not be calibrated.

Inspect the Generator

Refer to Safety Section, "Generator Isolating for Maintenance" for information regarding the procedure to safely isolate the generator.

A visual inspection should be initially directed at the areas that are most prone to damage and deterioration. The most prone areas to damage and deterioration are listed below:

Ground insulation – Ground insulation is insulation that is intended to isolate components that are carrying current from components that are not carrying current.

Support insulation – Support insulation is usually made from one of the following items: a compressed lamination of fibrous materials, polyester, or felt pads that have been impregnated with various types of bonding agents.

There are many different types of damage that can occur in these areas. Several of the different types of damage are listed below:

Thermal aging – Thermal aging can cause the degradation of insulation or the deterioration of insulation. An examination of the coils may reveal that the insulation has expanded into the ventilation ducts. This is the result of a loss of bond which will cause the insulation material to separate. The insulation material could also separate from the conductors on the windings.

Abrasion – The surfaces of coils and the surfaces of connectors may be damaged by abrasion. These surfaces may also be damaged by contamination from other sources. An example of these sources would be chemicals or abrasive substances.

Cracking – Cracking of insulation may result from mechanical stress. The structure that is used to brace the stator winding will become loose if the problem is not corrected. Further mechanical damage or electrical damage may also result.

Erosion – Erosion can be caused when foreign substances rub against the insulation that is on the surface of the coil .

i01057943

Water Pump - Inspect

SMCS Code: 1361-040

A failed water pump might cause severe engine overheating problems that could result in the following conditions:

- Cracks in the cylinder head
- A piston seizure
- Other potential damage to the engine

Visually inspect the water pump for leaks. If any leaking is observed, replace the water pump seal or the water pump assembly. Refer to the Service Manual for the disassembly and assembly procedure.

Note: Refer to the Service Manual or consult your Caterpillar dealer if any repair is needed or any replacement is needed.

i02903565

Winding - Test

SMCS Code: 4453-081; 4454-081; 4457-081;
4470-081

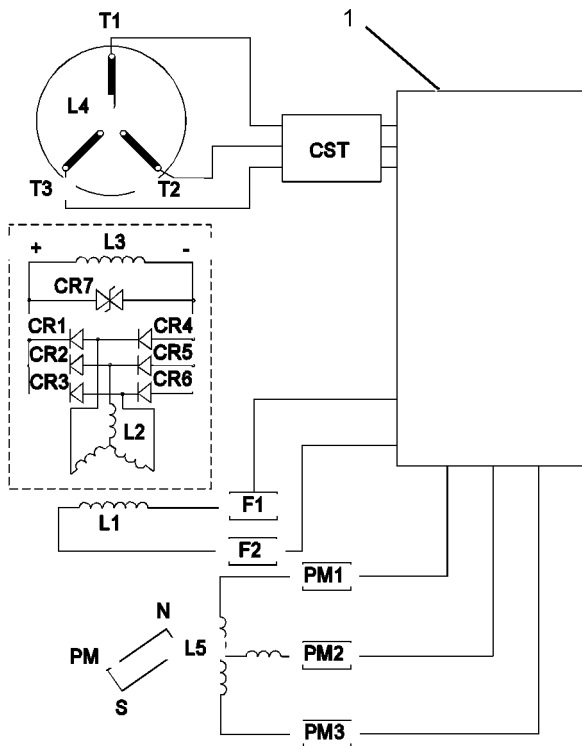

Illustration 78

g01445763

PMPE generator wiring diagram

- (1) Voltage regulator and/or related components
- (CR1) Diode
- (CR2) Diode
- (CR3) Diode
- (CR4) Diode
- (CR5) Diode
- (CR6) Diode
- (CR7) Varistor
- (L1) Exciter field (stator)
- (L2) Exciter armature (rotor)
- (L3) Main field (rotor)
- (L4) Main armature (stator)
- (L5) Pilot exciter armature
- (PM) Permanent magnet
- (RFA) Rotating field assembly
- (CST) Customer supplied transformer

Table 18

Tools Needed		
Part Number	Part ⁽¹⁾	Quantity
6V-7070	Digital Multimeter	1
146-4080	Digital Multimeter (RS232)	1

(1) Only one multimeter is necessary for this test. Either of the multimeters that are shown will work.

WARNING

The high voltage that is produced by an operating generator set can cause severe injury or death. Before performing any maintenance or repairs, ensure that the generator will not start.

Place the engine control switch in the "OFF" position. Attach "DO NOT OPERATE" tags to all starting controls. Disconnect the batteries or disable the starting system. Lock out all switchgear and automatic transfer switches that are associated with the generator.

Measure the resistance of the following windings: (L1), (L2), (L3), (L4), and (L5). The winding that is being tested must be disconnected from the other components before the resistance can be measured. The following resistance measurements are approximations. If the measured value is not near the listed approximation, the winding is probably damaged. For a more precise resistance value, consult the Technical Marketing Information (TMI). Refer to the generator arrangement that is in question.

Note: The winding temperature affects the resistance. When the winding temperature increases, the winding resistance also increases. When the winding temperature decreases, the winding resistance also decreases. Therefore, a correct measurement can be performed only when the winding is at room temperature.

The following armature windings have very little resistance: (L2), (L4), and (L5). The resistance of these windings will measure near 0 ohms. Use a milliohm meter to measure the resistance of the armature windings.

Exciter armature (rotor) – less than 0.1 ohm

Main armature (stator) – less than 0.1 ohm

Pilot exciter armature (L5) – less than 0.1 ohm

Use a multimeter in order to measure the resistance of field windings (L1) and (L3).

Exciter field (stator) (L1) – approximately 3.0 ohms to 6.0 ohms

Main field (rotor) (L3) – approximately 1.25 ohms to 2.0 ohms

Note: There should be no continuity between any winding and ground. There should be no continuity between any winding and another winding.

Reference Information Section

i01250210

Engine Ratings

i00727327

Engine Rating Conditions

SMCS Code: 1000

All engine ratings are in compliance with the following standard ambient air conditions of “SAE J1349”:

- 99 kPa (29.3 inches of Hg)
- 30 percent relative humidity
- A temperature of 25 °C (77 °F)

Ratings relate to the standard conditions of “ISO8665”, of “ISO3046/1”, of “DIN6271”, and of “BS5514”.

The engine ratings are based on the following fuel specifications:

- Low heat value (LHV) of the fuel of 42 780 kJ/kg (18,390 Btu/lb) at 29 °C (84 °F)
- Gravity (API) of 35 degrees at 15 °C (60 °F)
- Specific gravity of .849 at 15 °C (60 °F)
- Density of 850 kg/m³ (7.085 lb/US gal)

The engine ratings are gross output ratings.

Gross Output Ratings – The total output capability of the engine that is equipped with standard accessories.

Standard accessories include the following components:

- Oil pumps
- Fuel pumps
- Water pumps

Subtract the power that is required to drive auxiliary components from the gross output. This will produce the net power that is available for the external load (flywheel).

Engine Rating Definitions

SMCS Code: 1000

The ratings must be reduced in order to accommodate changes in the altitude. The ratings must be reduced according to the data for derating that is obtained from the test specification for the engine.

All of the ratings that are defined have a manufacturing tolerance of \pm three percent.

Use the following guidelines in order to determine the applicable engine rating.

NOTICE

Operating an engine at a greater power output than the engine is rated for will reduce the service life of the engine before overhaul.

Ratings for Generator Set Engines

Load Factor – The sum of the loads divided by the number of hours of operation. Idle time and down time are not part of the calculation.

Power Interruption – Unexpected failure of the utility power supply.

Operating Cycle – Unless the operating cycle is specified differently, the operating cycle for calculating the load factors and the peak load limits is not to exceed 24 hours. The operating cycle does not include the time when the engine is not operating.

Continuous – This rating allows a constant load or a load that varies for an unlimited number of hours per year. The normal load factor is up to 100 percent for an unlimited number of hours per year. The following applications are suggested: base load, utility, cogeneration, and parallel operation.

Prime – This rating allows a load that varies for an unlimited number of hours per year. The normal load factor is up to 80 percent for an unlimited number of hours per year. A 100 percent load is only allowed for 5 percent of the operating cycle. The following applications are suggested: industrial, pumping, construction, and cogeneration.

Prime + 10% (Standby applications for a power supply from a reliable utility) – This rating allows a load that varies up to the Prime rating. An additional ten percent is allowed for the duration of the power interruption. The normal load factor is up to 80 percent for 100 hours per year. A 100 percent load is only allowed for 5 percent of the operating cycle. The suggested application is Standby for a power supply from a reliable utility.

Prime + 10% (Applications that are industrial, pumping, construction, and cogeneration) – This rating allows a load that varies up to the Prime rating. The normal load factor is up to 80 percent for an unlimited number of hours per year. A load of 100 percent is only allowed for 5 percent of the operating cycle. The following applications are suggested: industrial, pumping, construction, and cogeneration.

Standby – This rating allows a load that varies for the duration of the power interruption. The normal load factor is up to 80 percent for 100 hours per year. A 100 percent load is only allowed for 5 percent of the operating cycle. The suggested application is Standby for a power supply from a reliable utility.

Load Management Peak Shaving Rating Guidelines

Interruptable (Isolated from the utility with a Standby base rating for load factors) – This rating allows a load that varies for less than 12 hours per day. The typical peak load factor is up to 80 percent for less than 500 hours per year. The peak operating limit is a load factor up to 100 percent. A 100 percent load is only allowed for 5 percent of the operating cycle. The operating cycle for calculating the load factors and the peak load limits is not to exceed six hours. The operating cycle does not include the time when the engine is not operating.

Interruptable (Isolated from the utility with a Prime base rating for load factors) – This rating allows a load that varies for more than 12 hours per day. The typical peak load factor is up to 80 percent for an unlimited number of hours per year. The peak operating limit is a load factor up to 100 percent. A 100 percent load is only allowed for 5 percent of the operating cycle.

Curtable (Connected to a utility with a special base rating for load factors) – This rating allows a constant load or a load that varies for less than six hours per day. The typical peak load factor is up to 100 percent for a maximum of 500 hours per year. The peak operating limit is up to 100 percent load for a maximum of 500 hours per year.

Curtable (Connected to a utility with a Continuous base rating for load factors) – This rating allows a constant load or a load that varies for more than six hours per day. The normal load factor is up to 100 percent for an unlimited number of hours per year. The peak load factor is up to 100 percent for an unlimited number of hours per year.

Industrial Engine Ratings

“IND A” (Continuous) – This rating allows operation at the engine’s rated load and speed for 100 percent of the time without interruption or load cycling. The engine may be operated at full load for 100 percent of the duty cycle. The following applications are typical: pipeline pumping, ventilation, and applications that are specified by the customer.

“IND B” – This rating is for service with power and/or speed that is cyclic. The time at full load is not to exceed 80 percent of the duty cycle. The following applications are typical: irrigation with a normal pump demand that is 85 percent of the engine rating, mechanical pumping and/or drilling in an oil field, and stationary plant air compressors.

“IND C” (Intermittent) – This rating is for service with power and/or speed that is cyclic. The engine can be operated continuously for one hour at the “C”. This is followed by one hour of operation at the “A” rating or below the “A” rating. Continuous power may be supplied by engines with the “C” rating. However, full load operation is not to exceed 50 percent of the duty cycle. The following applications are typical: agricultural tractors, harvesters, combines, off-highway trucks, power for fire pumps, drilling for blast holes, rock crushers with high torque rise, wood chippers with high torque rise, and oil field hoisting.

Customer Service

i03201484

Customer Assistance

SMCS Code: 1000; 4450

USA and Canada

When a problem arises concerning the operation of an engine or concerning the service of an engine, the problem will normally be managed by the dealer in your area.

Your satisfaction is a primary concern to Caterpillar and to Caterpillar dealers. If you have a problem that has not been handled to your complete satisfaction, follow these steps:

1. Discuss your problem with a manager from the dealership.
2. If your problem cannot be resolved at the dealer level without additional assistance, use the phone number that is listed below to talk with a Field Service Coordinator:

1-800-447-4986

The normal hours are from 8:00 to 4:30 Monday through Friday Central Standard Time.

3. If your needs have not been met still, submit the matter in writing to the following address:

Caterpillar Inc.
Marine Center of Excellence
Manager, Customer Service
111 Southchase Blvd
Fountain Inn, SC 29644

Please keep in mind: probably, your problem will ultimately be solved at the dealership, using the dealership's facilities, equipment, and personnel. Therefore, follow the steps in sequence when a problem is experienced.

Outside of the USA and of Canada

If a problem arises outside the USA and outside Canada, and if the problem cannot be resolved at the dealer level, consult the appropriate Caterpillar office.

Latin America, Mexico, Caribbean
Caterpillar Americas Co.
701 Waterford Way, Suite 200
Miami, FL 33126-4670
USA
Phone: 305-476-6800
Fax: 305-476-6801

Europe, Africa, and Middle East
Caterpillar Overseas S.A.
76 Route de Frontenex
P.O. Box 6000
CH-1211 Geneva 6
Switzerland
Phone: 22-849-4444
Fax: 22-849-4544

Far East
Caterpillar Asia Pte. Ltd.
7 Tractor Road
Jurong, Singapore 627968
Republic of Singapore
Phone: 65-662-8333
Fax: 65-662-8302

China
Caterpillar China Ltd.
37/F., The Lee Gardens
33 Hysan Avenue
Causeway Bay
G.P.O. Box 3069
Hong Kong
Phone: 852-2848-0333
Fax: 852-2848-0440

Japan
Shin Caterpillar Mitsubishi Ltd.
SBS Tower
10-1, Yoga 4-Chome
Setagaya-Ku, Tokyo 158-8530
Japan
Phone: 81-3-5717-1150
Fax: 81-3-5717-1177

Japan
Caterpillar Power Systems, Inc.
SBS Tower (14th floor)
4-10-1, Yoga
Setagaya-Ku, Tokyo 158-0097
Phone: 81-3-5797-4300
Fax: 81-3-5797-4359

Australia and New Zealand
Caterpillar of Australia Ltd.
1 Caterpillar Drive
Private Mail Bag 4
Tullamarine, Victoria 3043
Australia
Phone: 03-9953-9333
Fax: 03-9335-3366

i01028392

Ordering Replacement Parts

SMCS Code: 4450; 7567

WARNING

When replacement parts are required for this product Caterpillar recommends using Caterpillar replacement parts or parts with equivalent specifications including, but not limited to, physical dimensions, type, strength and material.

Failure to heed this warning can lead to premature failures, product damage, personal injury or death.

Quality Caterpillar replacement parts are available from Caterpillar dealers throughout the world. Caterpillar dealers' parts inventories are up-to-date. The parts stocks include all of the parts that are normally needed to protect your Caterpillar engine investment.

When you order parts, please specify the following information:

- Part number
- Part name
- Quantity

If there is a question concerning the part number, please provide your dealer with a complete description of the needed item.

When a Caterpillar engine requires maintenance and/or repair, provide the dealer with all the information that is stamped on the Information Plate. This information is described in this Operation and Maintenance Manual (Product Information Section).

Discuss the problem with the dealer. Inform the dealer about the conditions of the problem and the nature of the problem. Inform the dealer about when the problem occurs. This will help the dealer in troubleshooting the problem and solving the problem faster.

Reference Materials

- Maintenance log

i00912149

Maintenance Records

SMCS Code: 1000; 4450

Caterpillar Inc. recommends the retention of accurate maintenance records. Accurate maintenance records can be used for the following purposes:

- Determine operating costs.
- Establish maintenance schedules for other engines that are operated in the same environment.
- Show compliance with the required maintenance practices and maintenance intervals.

Maintenance records can be used for a variety of other business decisions that are related to engine maintenance.

Maintenance records are a key element of a maintenance program that is well managed. Accurate maintenance records can help your Caterpillar dealer to fine tune the recommended maintenance intervals in order to meet the specific operating situation. This should result in a lower engine operating cost.

Records should be kept for the following items:

Fuel Consumption – A record of fuel consumption is essential in order to determine when the load sensitive components should be inspected or repaired. Fuel consumption also determines overhaul intervals.

Service Hours – A record of service hours is essential to determine when the speed sensitive components should be inspected or repaired.

Documents – These items should be easy to obtain, and these items should be kept in the engine history file. All of the documents should show this information: date, service hours, fuel consumption, unit number, and engine serial number. The following types of documents should be kept as proof of maintenance or repair for warranty:

Keep the following types of documents as proof of maintenance for warranty. Also, keep these types of documents as proof of repair for warranty:

- Dealer work orders and itemized bills
- Owner's repair costs
- Owner's receipts

i02413905

Reference Material

SMCS Code: 1000; 4450

The following publications can be obtained from any Caterpillar dealer.

Lubricants

- Special Publication, PELJ0179, "Caterpillar Engine Crankcase Fluid-1 Specifications (Cat ECF-1)" All international markets
- Data Sheet, PEHJ0008, "Cat Arctic DEO (SAE 0W-30)" Canada and the United States
- Data Sheet, PEHJ0021, "Cat DEO (SAE 10W-30 and SAE 15W-40)" Worldwide except North America, Egypt, Saudi Arabia, and Brazil
- Data Sheet, PEHJ0059, "Cat DEO (SAE 10W-30 and SAE 15W-40)" Canada, Mexico, and the United States
- Data Sheet, PEHP7062, "Cat DEO SYN (SAE 5W-40)"
- Special Publication, PEHP6001, "How To Take A Good Oil Sample"
- Special Publication, PEDP7036, "S-O-S Fluid Analysis"
- Data Sheet, PEHJ0088, "Cat Multipurpose Grease" (NLGI grade 2)
- Data Sheet, PEHP0002, "Cat Advanced 3Moly Grease" (NLGI grade 2)
- Data Sheet, NEHP6010, "Cat Ultra 5Moly Grease" (NLGI grades 1 and 2)
- Data Sheet, NEHP6015, "Cat High Speed Ball Bearing Grease" (NLGI grade 2)
- Special Publication, SEBU6251, "Caterpillar Commercial Diesel Engine Fluids Recommendations"
- Special Publication, SEBU5898, "Cold Weather Recommendations"

Fuels

- Engine Data Sheet, LEKQ4219, "Fuel Recommendations for Caterpillar Diesel Engines"
- Special Publication, SEBD0717, "Diesel Fuels and Your Engine"

- Special Publication, SEBU6251, "Caterpillar Commercial Diesel Engine Fluids Recommendations"

Coolants

- Data Sheet, PEHJ0067, "Cat ELC (Extended Life Coolant)" Worldwide
- Special Publication, PELJ0176, "Cat ELC (Extended Life Coolant) 223-9116 Dilution Test Kit"
- Special Publication, PEEP5027, "Label - ELC Radiator Label"
- Data Sheet, PEHP9554, "Cat DEAC (Diesel Engine Antifreeze/Coolant) (Concentrate)"
- Special Publication, PEDP7036, "S-O-S Fluid Analysis"
- Data Sheet, PEHP7057, "Coolant Analysis"
- Special Publication, SEBD0518, "Know Your Cooling System"
- Special Publication, SEBD0970, "Coolant and Your Engine"
- Special Publication, SEBU6251, "Caterpillar Commercial Diesel Engine Fluids Recommendations"

Miscellaneous

- Service Manual, RENR9970, "C27 and C32 Generator Set Engines"
- Specifications, RENR7167, "C27 and C32 Generator Set Engines"
- Troubleshooting, RENR9348, "C27 and C32 Generator Set Engines"
- Disassembly and Assembly, RENR9716, "C27 and C32 Generator Set Engines"
- Systems Operation/Testing And Adjusting , RENR9968, "C27 and C32 Generator Set Engines"
- Systems Operation/Testing And Adjusting , RENR7902, "Electronic Modular Control Panel 3 (EMCP3)"
- Service Manual, RENR7941, "Caterpillar Digital Voltage Regulator (CDVR)"
- Electrical Schematic, RENR7952, "C27 Generator Set Engines"

- Electrical Schematic, RENR9855, "C32 Generator Set Engines"
- Parts Manual, SEBP4150, "C32 Industrial Engine"
- Special Instruction, SEHS9031, "Storage Procedure for Caterpillar Products"
- Special Instruction, SEHS7332, "Warning Tag - Do Not Operate"
- Special Instruction, SEHS7633, "Battery Test Procedure"
- Special Publication, NEHS0526, "Service Technician Application Guide"
- Special Publication, NENG2500, "Caterpillar Dealer Service Tool Catalog"
- Special Publication, SEBF8029, "Index to Guidelines for Reusable Parts and Salvage Operations"
- Special Publication, SEBF8062, "Guideline for Reusable Parts - Cleaning and Inspection of Air Filters"
- Specifications, SENR3130, "Torque Specifications"
- Special Publication, PECP9067, "One Safe Source"

Additional Reference Material

The "Engine Fluids Data Book" can be obtained from the following locations: local technological society, local library, and local college. If necessary, consult EMA at the following address:

Engine Manufacturers Association
Two North LaSalle Street, Suite 2200
Chicago, IL, USA 60602
E-mail: ema@enginemanufacturers.org
Telephone: (312) 827-8700
Facsimile: (312) 827-8737

The "Society of Automotive Engineers (SAE) Specifications" can be found in your SAE handbook. This publication can also be obtained from the following locations: local technological society, local library, and local college. If necessary, consult SAE at the following address:

SAE International
400 Commonwealth Drive
Warrendale, PA, USA 15096-0001
Telephone: (724) 776-4841

The "American Petroleum Institute Publication No. 1509" can be obtained from the following locations: local technological society, local library, and local college. If necessary, consult API at the following address:

American Petroleum Institute
1220 L St. N.W.
Washington, DC, USA 20005
Telephone: (202) 682-8000

The International Organization for Standardization (ISO) offers information and customer service regarding international standards and standardizing activities. ISO can also supply information on the following subjects that are not controlled by ISO: national standards, local standards, regulations, certification, and related activities. Consult the member of ISO in your country.

International Organization for Standardization (ISO)
1, rue de Varembe
Case postale 56
CH-1211 Genève 20
Switzerland
Telephone: +41 22 749 01 11
Facsimile: +41 22 733 34 30
E-mail: central@iso.ch
Web site: <http://www.iso.ch>

European classifications are established by the Conseil International Des Machines a Combustion (CIMAC) (International Council on Combustion Engines).

CIMAC Central Secretariat
Lyoner Strasse 18
60528 Frankfurt
Germany
Telephone: +49 69 6603 1567
Facsimile: +49 69 6603 1566

101087950

Emissions Warranty Information

SMCS Code: 1000

This engine may be certified to comply with exhaust emission standards and gaseous emission standards that are prescribed by law at the time of manufacture, and this engine may be covered by an Emissions Warranty. A detailed explanation of the Emissions Warranty that is applicable to emissions certified engines is found in Supplement, SEBU6981, "Federal Emissions Control Warranty Information". Consult your authorized Caterpillar dealer to determine if your engine is emissions certified and if your engine is subject to an Emissions Warranty.

i00382622

Warranty Information

SMCS Code: 1000

Engine Protection Plans

Extended Warranties and Service Contracts

A wide variety of protection plans are available for Caterpillar Engines. Consult your Caterpillar dealer for detailed information on the specific programs and coverages that are available.

Consult your Caterpillar dealer for information on a plan that is tailored in order to fit your requirements.

i02342531

Symbols

SMCS Code: 1000; 4450; 4480; 4490

SYMBOL	DESCRIPTION	SYMBOL	DESCRIPTION	SYMBOL	DESCRIPTION	SYMBOL	DESCRIPTION	SYMBOL	DESCRIPTION
	WARNING		OIL FILTER		LOW FUEL LEVEL		LOW COOLANT TEMP		ENGINE INTAKE AIR DAMPER CLOSED
	DO NOT LIFT		OIL PRESSURE		FUEL FILTER		LOW COOLANT LEVEL		SYSTEM BATTERY VOLTAGE
	LIFTING		LOW OIL PRESSURE		DIESEL FUEL		ENGINE COOLANT FILL		LOW BATTERY VOLTAGE
	LAMP TEST		LOW OIL LEVEL		DIESEL FUEL FILL		COOLANT DRAIN		BATTERY CHARGER MALFUNCTION
	ALARM		OIL DRAIN		COOLANT TEMPERATURE		COOLANT FILTER		ADJUSTABLE LOW-HIGH
	AC VOLTS		EMERGENCY STOP		HIGH COOLANT TEMP		REVERSE POWER		PANEL ILLUMINATION LIGHT

SYMBOL	DESCRIPTION	SYMBOL	DESCRIPTION	SYMBOL	DESCRIPTION	SYMBOL	DESCRIPTION
	ALARM SILENCE		SERVICE HOURS		SYSTEM AUTO ENGINE START		HOT SURFACE
	RAISE		STARTING AID - ETHER		SYSTEM NOT IN AUTOMATIC START MODE		NO SERVICE READ MANUAL
	LOWER		AUTOMATIC		ENGINE RPM, ENGINE START OR ENGINE RUN		ENGINE COOLANT PRESSURE-HOT SURFACE
	ON		MANUAL		FAIL TO START, OVERCRANK		CIRCUIT BREAKER OPEN
	OFF		HIGH VOLTAGE		AMMETER VOLTMETER PHASE SELECTOR SWITCH		CIRCUIT BREAKER CLOSED
	ENGINE STOP		OVERSPEED		GENERATOR SYNCHRONIZING INDICATOR		FREQUENCY

Illustration 79

g01168026

The control panel and modules utilize International Graphic Symbols to identify functions. A typical list of the symbols that are used is shown above.

i01207219

Glossary

SMCS Code: 4450

Actuate – Actuation relates to putting something in motion.

Alternating Current (AC) – Alternating Current is an electric current that reverses direction at regular intervals (50 times per second in 50 Hz or 60 times per second in 60 Hz).

Anode – An anode is the positive end of a diode or an anode is the positive end of a rectifier.

Blocking Rectifier – A blocking rectifier permits direct current flow in only one direction.

Bolted – A bolted device uses a bolt to hold two or more parts together.

Bridge – A bridge is a circuit that is used to measure small quantities of current, voltage, or resistance.

Bridge Rectifier – A bridge rectifier is a circuit that is used to change alternating current (AC) to direct current (DC).

Buildup – A buildup is a gradual increase in voltage.

Cathode – A cathode is the negative end of a diode or a cathode is the negative end of a rectifier.

Capacitance – Capacitance is the ability to store an electrical charge.

Capacitor – A capacitor is a device that will store an electrical charge.

Circuit Breaker – A circuit breaker is an automatic switch that is used to open a circuit.

Circulating Current – Circulating current is the flow of current between two or more generators that are working in parallel. Circulating current is also the flow of current between two or more generators that are parallel with a utility line.

Conduct – Conducting relates to allowing the flow of current.

Constant Voltage Regulation – Constant Voltage Regulation is one of the two methods of voltage regulation. In order to maintain the line voltage, Constant voltage regulators allow the field to be forced to the saturation point. This allows the engine to be overloaded. On large block load applications, the engine may not recover.

Continuity – Continuity provides a path for current flow.

Control – A control is a device that controls another device. A control is also a circuit that controls a device.

Cross Current Compensation – Cross current compensation is a method that is used for reactive power equalization.

Current Transformer (CT) – A current transformer is used to step down higher line current.

Direct Current (DC) – Direct current is current flow that moves in only one direction in a given circuit.

Damping – Damping refers to decreasing the amplitude of a signal.

De-energized – A de-energized input refers to stopping the current that is going to a component.

Distribution Winding – Distribution windings go from one end of the core to the other end of the core. These windings are arranged in groups that are located in several slots.

Droop – Droop refers to a decrease.

Excitation – Excitation is controlled direct current (DC) that is used to make a magnetic field.

Energized – An energized input refers to activating a device.

Electrostatic Charge – Electrostatic charge is electricity that is caused by induced voltage and stored charge.

Exciter – An exciter supplies direct current (DC) to the field windings of the generator.

Field – A field is a magnetic line of force that surrounds a conductor. This force is caused by current flow in the conductor.

Field Windings – Field windings are many turns of wire that are wrapped around an iron core. When direct current (DC) flows through the field windings, a magnetic field is produced. This magnetic field is comparable to the magnetic field of a bar magnet.

Flashing – Flashing is a process of putting direct current from an external source into the field windings. This process causes the generator to produce an output voltage.

Flux – Flux is magnetic lines of force.

Frequency – Frequency is the number of cycles that are completed in a one second period. The unit of frequency is the Hertz (Hz). One hertz is equal to one cycle per second.

Full-Wave Rectifier – A full-wave rectifier changes the positive phase and the negative phase of alternating current to direct current.

Gain – Gain relates to the ratio of input magnitude to output magnitude.

Gate – A gate is an electronic part of a controlled rectifier (thyristor).

Generate – The production of electricity.

Grounded – A device is grounded by making a connection to ground. A device could also be grounded by making a connection to a component that is connected to ground.

Hertz (Hz) – Hertz is the unit of measurement for frequency. One hertz is equal to one cycle per second.

Humidity – Humidity is the water content that is present in the air.

Impedance – Impedance is the resistance to alternating current.

Impulse Modulation – Impulse modulation changes the following characteristics of a wave: amplitude, frequency, and phase. This is accomplished by impressing one wave on another wave that has constant properties.

Induce – This refers to the transfer of power from one device to another device. The transfer is done via a magnetic field or via an electric field.

Interference – Interference is an unwanted mixture of electrical signals. Interference is usually associated with electrical noise.

Instrumentation – Instrumentation is a group of instruments that are used for measuring a system function.

Insulated – An insulated device is a device that is covered with a nonconductive material.

kVA – This is the abbreviation for Kilovolt Amperes. kVA is a term that is used when electrical devices are rated. In order to calculate a device's kVA rating, multiply the rated output (amperes) by the rated operating voltage.

KVAR – Kilovolt Amperes Reactive is abbreviated as KVAR. KVAR is associated with the reactive power that flows in a power system. Reactive power does not load the generator set's engine. Reactive power will cause thermal loss in the generator.

KVAR Regulation – KVAR Regulation is one of the two methods that are used to regulate the reactive power output. Regardless of the generator's real power output, the voltage regulator causes the generator to produce a constant value of KVAR. In this case, the generator's power factor will change when the generator's real power output changes. KVAR regulation is used when the generator is connected in parallel with an infinite bus (utility) and it is not possible to change the system voltage.

Kilowatts (kW) – Kilowatt is the electrical rating of the generator. One kilowatt equals 1000 watts. Actual power is measured in kilowatts.

Lead – A lead is a wire.

Line Voltage – Line voltage is the output voltage of the generator that is measured between the generator leads (phases).

Lock In – Lock in occurs when a contact closes in order to keep a device in an energized state.

Lock Out – Lockout occurs when a contact opens in order to keep a device in a de-energized state.

Magnetic – A magnetic device is a device that has the characteristics of a magnet.

Magnification – Magnification refers to the enlargement of an item.

Module – A module is an assembly of electronic components and electronic circuits.

Moisture – Moisture is the presence of water.

Oscillation – Oscillation is the flow of electricity that periodically changes direction and/or magnitude.

Permanent Magnet (PM) – A permanent magnet supplies the initial magnetism that is required to start a PMPE generator.

Permanent magnet pilot excited (PMPE) – A PMPE generator receives power for the voltage regulator from a pilot exciter. A PMPE generator consists of a permanent magnet and a pilot exciter.

PF Regulation – PF Regulation is one of the two ways to regulate the reactive power output. PF regulation is used when the generator is connected in parallel with an infinite bus (utility) and it is not possible to control the system voltage.

Phase Winding – A phase winding is a group of generator stator coils. Electric power for one phase of the load is induced in the phase winding.

Polarity – Polarity is the positive characteristics or the negative characteristics of two poles.

Power Factor (PF) – Power factor is the ratio of apparent power (kVA) to total power (kW). The power factor represents the portion of the current that is doing useful work. Power factor is expressed as a decimal number between 0 and 1.

Pulsating – Pulsating relates to the characteristics of current that are similar to mechanical vibration.

Radio Suppression – Radio suppression reduces the amplitude of radio frequency interference.

Reactive Droop Compensation – Reactive Droop Compensation is one of the two methods that are used for reactive power equalization. In reactive droop compensation, the voltage regulator causes an individual generator output to change in proportion to the reactive current. This reactive current is measured with a current transformer.

Reactive Power – Reactive power flows back and forth between the inductive windings of the generator. These windings are part of the electrical load. The reactive power does not perform any useful work in the electrical load. The reactive power only applies load to the generator. This limits the generator's capacity.

Reciprocating – Reciprocating motion is motion that first moves in a straight line in one direction. The direction of this motion then varies by 180 degrees.

Rectifier – A rectifier is a diode circuit that converts alternating current (AC) to direct current (DC).

Regenerative Power – Regenerative power works against primary power.

Reset – A reset returns a switch to a ready condition. In addition, a reset returns a circuit to a ready condition.

Residual Magnetism – Residual magnetism is a small amount of magnetism that is remaining in a device after excitation is removed.

RFA – An RFA is a rotating field assembly.

Rotating Rectifier – A rotating rectifier is mounted to a plate on a generator shaft. This plate then rotates with the generator shaft.

Rotor – A rotor is the rotating windings of a generator.

Saturable Reactor – A saturable reactor has characteristics that are similar to a valve. As the load changes, a valve opens in order to give more current to the output or a valve closes in order to give less current to the output.

Saturated – A device has been saturated when the device has been magnetized in excess. When saturation occurs, a large increase in current results in a small increase in magnetic force.

SCR – An SCR is a silicon controlled rectifier. An SCR is a semiconductor.

SE – An SE generator is a self-excited generator. An SE generator uses a small part of the generator output to provide excitation current back to the generator. An SE generator uses residual magnetic field for start-up.

Semiconductor – A semiconductor is a component such as one of the following components: a transistor, a diode, and a thyristor. Semiconductors have electrical characteristics that are between a conductor and insulation.

Series Boost – A series boost is an attachment that allows generator output to continue for a short time during a line failure. This allows the circuit breaker to trip in sequence.

Short – A short is an undesired electrical connection that exists between two or more components.

Shutdown – A shutdown occurs when the engine is stopped. This shutdown can occur manually or this shutdown can occur automatically.

Simultaneous – A simultaneous occurrence refers to two actions that happen at the same time.

Solid-State – A solid-state component is an electrical component that has no moving parts.

Stator – A stator is the windings of a generator that do not rotate.

Surge – A surge is a sudden increase in voltage or current.

Tap – A tap is a connection at the midpoint of a circuit. From this tap, power is taken from the circuit.

Transfer – A transfer refers to moving something from one point to another point. A transfer also refers to converting something from one state to another state.

Transient Peak Voltage – A transient peak voltage is a high voltage condition of limited duration.

Turn-on – When a device is turned on, the device is activated or the device is started.

Varistor – A varistor is a device that loses resistance as voltage increases.

Voltage Droop Resistor – A voltage droop resistor is a variable resistor. This resistor is used to control the change of voltage. This can occur when a generator is paralleled with another generator. This can also occur when the generator is paralleled with a utility.

Voltage Level Rheostat – A voltage level rheostat gives a range of control that is used when the voltage output level is adjusted.

Voltage Regulator – A voltage regulator is a circuit that senses the generator's output voltage. The field coil current is automatically adjusted in order to maintain the desired output.

Voltage Spike – A voltage spike is a brief high voltage.

Volts per Hertz Regulation – Under block loading conditions, the Volts per Hertz Regulation provides fast recovery. This regulation maintains close voltage control over the normal load range. This regulation also produces a rapid response of the generator set. This control is maintained by matching the generator output to the engine performance.

Windings – Windings are layers of wire on a core.

Wiring – Wiring relates to the wires of a circuit.

Wound – Wound refers to being circled.

Index

A

After Starting Engine	54
After Stopping Engine.....	56
Air Inlet Filter - Check.....	77
Alternator - Inspect	77

B

Batteries - Replace	77
Battery - Recycle	77
Battery Charger - Check.....	78
Checking After Stopping	78
Checking Before Start-Up	78
Battery Electrolyte Level - Check	78
Battery or Battery Cable - Disconnect	79
Bearing - Inspect	80
Bearing (Ball) - Lubricate (Generator)	79
Lubricating Process	79
Bearing Temperature - Measure/Record	83
Before Starting Engine	17, 52
Belts - Inspect/Adjust/Replace.....	83
Alternator Belt Adjustment	84
Inspection.....	83
Replacement.....	83
Burn Prevention.....	14
Batteries.....	14
Coolant.....	14
Oils.....	14

C

Cold Weather Operation.....	57
Cold Weather Starting	52
Control Panel - Inspect.....	84
Annunciator Panel.....	84
Electronic Modular Control Panel 3 (EMCP 3)...	84
Switch Panel	84
Cooling System Coolant (DEAC) - Change.....	85
Cooling Systems with Heavy Deposits or Plugging	86
Drain	85
Fill	86
Flush	85
Cooling System Coolant (ELC) - Change.....	87
Drain	87
Fill	87
Flush	87
Cooling System Coolant Extender (ELC) - Add.....	88
Cooling System Coolant Level - Check	89
Cooling System Coolant Sample (Level 1) - Obtain	89
Cooling System Coolant Sample (Level 2) - Obtain	90

Cooling System Supplemental Coolant Additive (SCA) - Test/Add.....	90
Cooling Systems that Use Conventional Coolant.....	91
Cooling Systems that Use Water and SCA.....	91
Cooling System Water Temperature Regulator - Replace.....	92
Crankshaft Vibration Damper - Inspect	92
Visconic Damper.....	92
Crushing Prevention and Cutting Prevention	17
Customer Assistance.....	128
Outside of the USA and of Canada.....	128
USA and Canada	128
Customer Service	128

E

Electrical Connections - Check.....	93
Electrical System	18
Grounding Practices	18
Electronic Modular Control Panel 3 (EMCP 3).....	47
Annunciator Module	51
Control Panel	49
Electronic Control Module (Generator Set).....	47
Electronic Modular Control Panel II+ with Paralleling (EMCP II+P) (If Equipped).....	38
Alarm Module.....	46
Custom Alarm Module	46
Generator Set Control + (GSC+)	40
Emergency Stopping	56
Emergency Stop Button	56
Emissions Certification Film	26
Emissions Warranty Information.....	133
Engine - Clean.....	93
Engine Air Cleaner Element (Dual Element) - Clean/Replace (If Equipped).....	93
Inspecting and Replacing the Secondary Air Cleaner Element (If Equipped).....	93
Engine Air Cleaner Service Indicator - Inspect (If Equipped)	94
Test the Service Indicator.....	94
Engine Crankcase Breather - Clean.....	95
Engine Mounts - Check	95
Engine Oil and Filter - Change	97
Drain the Engine Oil.....	97
Fill the Engine Crankcase	98
Replace the Oil Filter	97
Engine Oil Level - Check	95
Engine Oil Sample - Obtain	96
Obtain the Sample and the Analysis.....	96
Engine Operation.....	55
Engine Protective Devices - Check	98
Visual Inspection.....	98
Engine Rating Conditions	126
Engine Rating Definitions	126
Industrial Engine Ratings	127
Ratings for Generator Set Engines	126

Engine Ratings 126
Engine Starting 17, 52
Engine Stopping 18, 56
Engine Valve Lash - Inspect/Adjust 98

F

Fan Drive Bearing - Lubricate 99
Features and Controls 38
Fire Prevention and Explosion Prevention 15
 Ether 16
 Fire Extinguisher 16
 Lines, Tubes and Hoses 16
Foreword 5
 California Proposition 65 Warning 5
 Literature Information 4
 Maintenance 4
 Maintenance Intervals 4
 Operation 4
 Overhaul 4
 Safety 4
Fuel and the Effect from Cold Weather 57
Fuel Conservation Practices 55
Fuel Injector - Inspect/Adjust 99
Fuel Related Components in Cold Weather 57
 Fuel Filters 58
 Fuel Heaters 58
 Fuel Tanks 57
Fuel System - Prime 99
Fuel System Primary Filter (Water Separator)
 Element - Replace 101
 Replace the Element 101
Fuel System Primary Filter/Water Separator -
 Drain 102
Fuel System Secondary Filter - Replace 102
Fuel Tank Water and Sediment - Drain 103
 Drain the Water and the Sediment 103
 Fuel Storage Tanks 103
 Fuel Tank 103

G

General Hazard Information 12
 Asbestos Information 13
 Containing Fluid Spillage 13
 Dispose of Waste Properly 14
 Fluid Penetration 13
 Pressurized Air and Water 13
 Softwrap 14
General Maintenance Information 68
Generator - Dry 103
 Drying Methods 104
Generator - Inspect 104
 Cleaning (Assembled Generators) 104
 Cleaning (Disassembled Generators) 105
Generator Isolating for Maintenance 19

Generator Lead Connections 28
 Grounding the Frame 30
 Lead Numbering 28
 Multiple Units 30
 Neutral Connections 30
 Parallel to Utility 30
 Single Units 30
Generator Load - Check 105
Generator Operation 59
 Block Loading 59
 Excitation Systems 60
 Generator Options 61
 Loading of the Generator 59
 Low Idle Adjustment 60
 Power Factor 60
 Standby Generator Sets 60
Generator Set - Test 106
Generator Set Installation 36
 Alignment 37
 Bearing Inspection 36
 Electrical Measurements 37
 Location 36
 Protective Devices 37
 Receiving Inspection 36
 Storage 36
 Unpacking and Storage 36
Generator Set Vibration - Inspect 107
Generator Start-up Checklist 70
Glossary 135

H

Heat Shield - Inspect/Replace 107
Hoses and Clamps - Inspect/Replace 107
 Replace the Hoses and the Clamps 108

I

Important Safety Information 2
Installation 36
Insulation - Test 108
 Recommended Periodic Insulation Test
 Procedure 109
 Recommended Periodic Insulation Tests 108

J

Jacket Water Heater - Check (Standby Generator
Sets (If Equipped)) 111

L

Lifting and Storage 34

M

Maintenance Interval Schedule (Standard)	75
Maintenance Interval Schedule (Standby).....	73
Maintenance Log	131
Maintenance Recommendations	68
Maintenance Records.....	130
Maintenance Section	66
Manual Stop Procedure.....	56
Model View Illustrations.....	20
Model Views and Specifications	20
Mounting and Dismounting.....	17

O

Operation Section.....	34
Ordering Replacement Parts	129
Overhaul Considerations	111
Oil Consumption as an Overhaul Indicator	111
Overhaul Recommendation	112

P

Parallel Operation.....	61
Circulating Currents	63
Initial Start-Up	61
Load Division and Speed Droop (If Equipped)...	63
Paralleling Multiple Units.....	62
Starting Multiple Units.....	62
Stopping.....	63
Plate Locations and Film Locations.....	25
Engine Identification Plate (2).....	25
Engine Serial Number Plate (3).....	26
Generator Identification Plate (1).....	25
Power Factor - Check.....	114
Prelube Pump - Inspect.....	114
Product Description	22
Engine Cooling and Lubrication	23
Engine Description.....	22
Generator Description.....	23
Product Identification Information	25
Product Information Section	20
Product Lifting.....	34
Lifting the Engine Only.....	34
Lifting the Entire Package	34
Lifting the Generator Only	34
Product Storage.....	35

R

Radiator - Clean	114
Reference Information	27
Record for Reference.....	27
Reference Information Section.....	126

Reference Material	132
Additional Reference Material.....	133
Coolants.....	132
Fuels	132
Lubricants	132
Miscellaneous	132
Reference Materials	130
Refill Capacities.....	66
Refill Capacities and Recommendations.....	66
Cooling System.....	67
Fuel.....	66
Lubrication System	66
Rotating Rectifier - Check.....	115
Testing a Three-Diode Rectifier Block.....	115

S

Safety Messages	6
Safety Section	6
Single Unit Operation	63
Initial Start-Up	63
Starting.....	63
Stopping.....	63
Space Heater - Check	116
Speed Sensor - Clean/Inspect.....	116
Standby Generator Set Maintenance	
Recommendations.....	118
Maintenance and Operation Procedures	118
Starting Motor - Inspect (If equipped).....	119
Air Starting Motor	119
Electric Starting Motor.....	119
Removal and Installation of the Starting Motor ..	119
Starting the Engine (EMCP 3)	53
Starting with Jump Start Cables	54
Stator Lead - Check.....	119
Stator Winding Temperature - Measure/Record ..	120
Symbols.....	134
System Pressure Release.....	68
Coolant System.....	68
Engine Oil	69
Fuel System	68

T

Table of Contents.....	3
Turbocharger - Inspect	120
Cleaning and Inspecting	120
Removal and Installation.....	120

V

Varistor - Test.....	121
Ohmmeter	121
Test Light.....	122
Voltage and Frequency - Check	122

Voltage Connections.....	30
Single-Phase Current From a Three-Phase Generator	32
Three-Phase Voltage Connections	30
Voltage Regulator Options.....	65
Manual Voltage Control.....	65
Voltage Regulators	64
Caterpillar Digital Voltage Regulator (CDVR)	64

W

Walk-Around Inspection	122
Inspect the Engine for Leaks and for Loose Connections	122
Inspect the Generator	123
Warranty Information	134
Engine Protection Plans.....	134
Water Pump - Inspect.....	123
Welding on Engines with Electronic Controls	69
Winding - Test.....	124

Product and Dealer Information

Note: For product identification plate locations, see the section "Product Identification Information" in the Operation and Maintenance Manual.

Delivery Date: _____

Product Information

Model: _____

Product Identification Number: _____

Engine Serial Number: _____

Transmission Serial Number: _____

Generator Serial Number: _____

Attachment Serial Numbers: _____

Attachment Information: _____

Customer Equipment Number: _____

Dealer Equipment Number: _____

Dealer Information

Name: _____ Branch: _____

Address: _____

Dealer Contact

Phone Number

Hours

Sales: _____

Parts: _____

Service: _____

