



**ENGINE OPERATION and MAINTENANCE
MANUAL**

**XP950HACAT
XP1060HACAT
SHP825WCAT
MHP825WCAT**

VHP750WCAT

**XHP650WCAT
XHP750WCAT**

Code:

Code: B

Code : C

**This manual contains important safety information.
Do not destroy this manual.
This manual must be available to the personnel who operate and maintain this machine.**

*Portable Power
P.O. Box 868
501 Sanford Ave
Mocksville, N.C. 27028
www.portablepower.irco.com*

Operation and Maintenance Manual

C-9 Engine

CLJ1-Up (Engine)



Important Safety Information

Most accidents that involve product operation, maintenance and repair are caused by failure to observe basic safety rules or precautions. An accident can often be avoided by recognizing potentially hazardous situations before an accident occurs. A person must be alert to potential hazards. This person should also have the necessary training, skills and tools to perform these functions properly.

Improper operation, lubrication, maintenance or repair of this product can be dangerous and could result in injury or death.

Do not operate or perform any lubrication, maintenance or repair on this product, until you have read and understood the operation, lubrication, maintenance and repair information.

Safety precautions and warnings are provided in this manual and on the product. If these hazard warnings are not heeded, bodily injury or death could occur to you or to other persons.

The hazards are identified by the "Safety Alert Symbol" and followed by a "Signal Word" such as "DANGER", "WARNING" or "CAUTION". The Safety Alert "WARNING" label is shown below.



The meaning of this safety alert symbol is as follows:

Attention! Become Alert! Your Safety is Involved.

The message that appears under the warning explains the hazard and can be either written or pictorially presented.

Operations that may cause product damage are identified by "NOTICE" labels on the product and in this publication.

Caterpillar cannot anticipate every possible circumstance that might involve a potential hazard. The warnings in this publication and on the product are, therefore, not all inclusive. If a tool, procedure, work method or operating technique that is not specifically recommended by Caterpillar is used, you must satisfy yourself that it is safe for you and for others. You should also ensure that the product will not be damaged or be made unsafe by the operation, lubrication, maintenance or repair procedures that you choose.

The information, specifications, and illustrations in this publication are on the basis of information that was available at the time that the publication was written. The specifications, torques, pressures, measurements, adjustments, illustrations, and other items can change at any time. These changes can affect the service that is given to the product. Obtain the complete and most current information before you start any job. Caterpillar dealers have the most current information available.



When replacement parts are required for this product Caterpillar recommends using Caterpillar replacement parts or parts with equivalent specifications including, but not limited to, physical dimensions, type, strength and material.

Failure to heed this warning can lead to premature failures, product damage, personal injury or death.

Table of Contents

Foreword 4

Safety Section

Safety Signs and Labels 6

General Hazard Information 7

Burn Prevention 10

Fire Prevention and Explosion Prevention 10

Crushing Prevention and Cutting Prevention 12

Mounting and Dismounting 13

Before Starting Engine 13

Engine Starting 13

Engine Stopping 14

Electrical System 14

Engine Electronics 15

Product Information Section

General Information 17

Model Views 18

Product Identification Information 21

Operation Section

Engine Lifting and Storage 25

Gauges and Indicators 26

Engine Features and Controls 30

Engine Diagnostics 34

Engine Starting 39

Engine Operation 45

Engine Stopping 46

Cold Weather Operation 48

Maintenance Section

Lubricant Specifications 50

Fuel Specifications 57

Cooling System Specifications 59

Refill Capacities 71

Maintenance Interval Schedule 72

Warranty Section

Warranty Information 111

Reference Information Section

Engine Ratings 112

Customer Service 114

Reference Materials 116

Index Section

Index 120

Foreword

Literature Information

This manual contains safety, operation instructions, lubrication and maintenance information. This manual should be stored in or near the engine area in a literature holder or literature storage area. Read, study and keep it with the literature and engine information.

English is the primary language for all Caterpillar publications. The English used facilitates translation and consistency in electronic media delivery.

Some photographs or illustrations in this manual show details or attachments that may be different from your engine. Guards and covers may have been removed for illustrative purposes. Continuing improvement and advancement of product design may have caused changes to your engine which are not included in this manual. Whenever a question arises regarding your engine, or this manual, please consult with your Caterpillar dealer for the latest available information.

Safety

This safety section lists basic safety precautions. In addition, this section identifies hazardous, warning situations. Read and understand the basic precautions listed in the safety section before operating or performing lubrication, maintenance and repair on this product.

Operation

Operating techniques outlined in this manual are basic. They assist with developing the skills and techniques required to operate the engine more efficiently and economically. Skill and techniques develop as the operator gains knowledge of the engine and its capabilities.

The operation section is a reference for operators. Photographs and illustrations guide the operator through procedures of inspecting, starting, operating and stopping the engine. This section also includes a discussion of electronic diagnostic information.

Maintenance

The maintenance section is a guide to engine care. The illustrated, step-by-step instructions are grouped by fuel consumption, service hours and/or calendar time maintenance intervals. Items in the maintenance schedule are referenced to detailed instructions that follow.

Use fuel consumption or service hours to determine intervals. Calendar intervals shown (daily, annually, etc.) may be used instead of service meter intervals if they provide more convenient schedules and approximate the indicated service meter reading.

Recommended service should be performed at the appropriate intervals as indicated in the Maintenance Interval Schedule. The actual operating environment of the engine also governs the Maintenance Interval Schedule. Therefore, under extremely severe, dusty, wet or freezing cold operating conditions, more frequent lubrication and maintenance than is specified in the Maintenance Interval Schedule may be necessary.

The maintenance schedule items are organized for a preventive maintenance management program. If the preventive maintenance program is followed, a periodic tune-up is not required. The implementation of a preventive maintenance management program should minimize operating costs through cost avoidances resulting from reductions in unscheduled downtime and failures.

Maintenance Intervals

Perform maintenance on items at multiples of the original requirement. Each level and/or individual items in each level should be shifted ahead or back depending upon your specific maintenance practices, operation and application. We recommend that the maintenance schedules be reproduced and displayed near the engine as a convenient reminder. We also recommend that a maintenance record be maintained as part of the engine's permanent record.

See the section in the Operation and Maintenance Manual, "Maintenance Records" for information regarding documents that are generally accepted as proof of maintenance or repair. Your authorized Caterpillar dealer can assist you in adjusting your maintenance schedule to meet the needs of your operating environment.

Overhaul

Major engine overhaul details are not covered in the Operation and Maintenance Manual except for the interval and the maintenance items in that interval. Major repairs are best left to trained personnel or an authorized Caterpillar dealer. Your Caterpillar dealer offers a variety of options regarding overhaul programs. If you experience a major engine failure, there are also numerous after failure overhaul options available from your Caterpillar dealer. Consult with your dealer for information regarding these options.

California Proposition 65 Warning

Diesel engine exhaust and some of its constituents are known to the State of California to cause cancer, birth defects, and other reproductive harm.

Battery posts, terminals and related accessories contain lead and lead compounds. **Wash hands after handling.**

Safety Section

Safety Signs and Labels

i01504798

SMCS Code: 1000; 7405

There may be several specific warning signs on an engine. The exact location of the hazards and the description of the hazards are reviewed in this section. Please become familiar with all warning signs.

Ensure that all of the warning signs are legible. Clean the warning signs or replace the warning signs if the words cannot be read or if the pictures are not visible. When the warning signs are cleaned, use a cloth, water, and soap. Do not use solvent, gasoline, or other harsh chemicals to clean the warning signs. Solvents, gasoline, or harsh chemicals could loosen the adhesive that secures the warning signs. The warning signs that are loosened could drop off of the engine.

Replace any damaged warning signs or missing warning signs. If a warning sign is attached to a part of the engine that is replaced, install a new warning sign on the replacement part. Any Caterpillar dealer can provide new warning signs.

WARNING

Do not operate or work on this engine unless you have read and understand the instructions and warnings in the Operation and Maintenance Manual. Failure to follow the instructions or heed the warnings could result in injury or death. Contact any Caterpillar dealer for replacement manuals. Proper care is your responsibility.

The warning labels that may be found on the engine are illustrated and described below.

Starting Aid

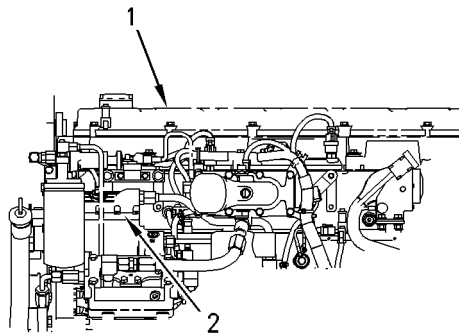

Illustration 1

g00780729

- (1) Valve cover
- (2) Hydraulic Pump

The warning label for the starting aid is located on the flat portion of the valve cover.



g00283559

If the engine is equipped with an air inlet heater for cold weather starting, the optional ether injection system is the only starting system that is recommended. Do not use starting aids that contain aerosols. Using such types of starting aids could result in an explosion and personal injury.

Clutch

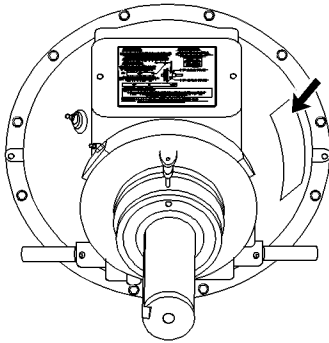
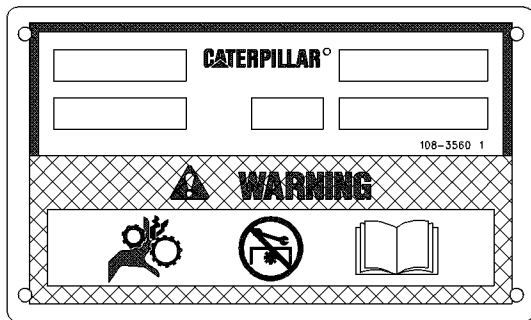

Illustration 2

g00107406

The warning label for the clutch is located on the clutch housing (if equipped).



g00107407

Rotating gears can cause entanglement of the fingers. Rotating gears can cause entanglement of the hands. Do not service this component without first reading the operator manual.

Engine Lifting

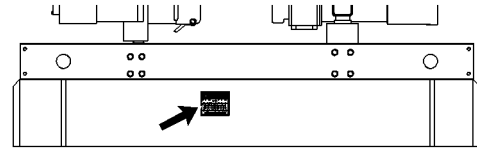
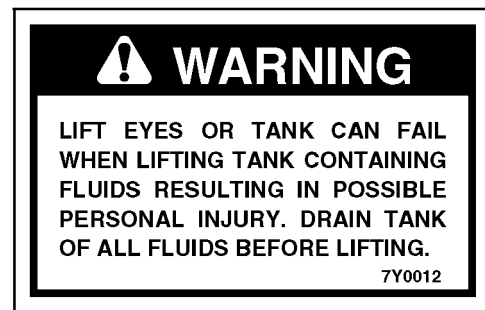

Illustration 3

g00367054

The warning label for lifting the engine with a fuel tank is located on the fuel tank (if equipped).



g00100728



Lift eyes or tank can fail when lifting tank containing fluids resulting in possible personal injury. Drain tank of all fluids before lifting.

i01377208

General Hazard Information

SMCS Code: 1000; 7405

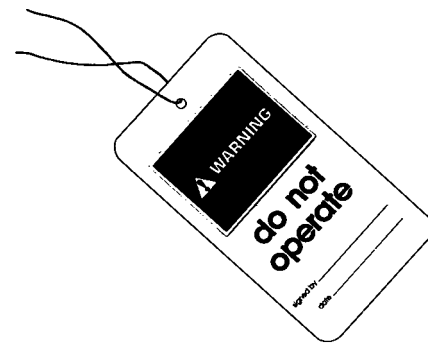

Illustration 4

g00104545

Attach a “Do Not Operate” warning tag or a similar warning tag to the start switch or to the controls before the engine is serviced or before the engine is repaired. These warning tags (Special Instruction, SEHS7332) are available from your Caterpillar dealer. Attach the warning tags to the engine and to each operator control station. When it is appropriate, disconnect the starting controls.

Do not allow unauthorized personnel on the engine, or around the engine when the engine is being serviced.

Engine exhaust contains products of combustion which may be harmful to your health. Always start the engine and operate the engine in a well ventilated area. If the engine is in an enclosed area, vent the engine exhaust to the outside.

Cautiously remove the following parts. To help prevent spraying or splashing of pressurized fluids, hold a rag over the part that is being removed.

- Filler caps
- Grease fittings
- Pressure taps
- Breathers
- Drain plugs

Use caution when cover plates are removed. Gradually loosen, but do not remove the last two bolts or nuts that are located at opposite ends of the cover plate or the device. Before removing the last two bolts or nuts, pry the cover loose in order to relieve any spring pressure or other pressure.

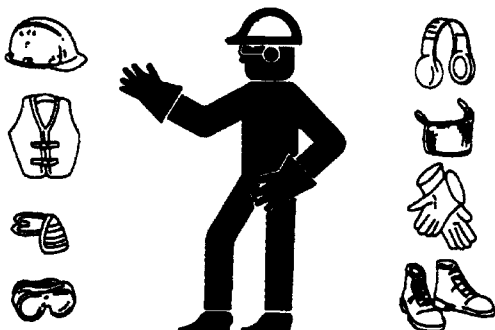

Illustration 5

g00702020

- Wear a hard hat, protective glasses, and other protective equipment, as required.
- When work is performed around an engine that is operating, wear protective devices for ears in order to help prevent damage to hearing.

- Do not wear loose clothing or jewelry that can snag on controls or on other parts of the engine.
- Ensure that all protective guards and all covers are secured in place on the engine.
- Never put maintenance fluids into glass containers. Glass containers can break.
- Use all cleaning solutions with care.
- Report all necessary repairs.

Unless other instructions are provided, perform the maintenance under the following conditions:

- The engine is stopped. Ensure that the engine cannot be started.
- Disconnect the batteries when maintenance is performed or when the electrical system is serviced. Disconnect the battery ground leads. Tape the leads in order to help prevent sparks.
- Do not attempt any repairs that are not understood. Use the proper tools. Replace any equipment that is damaged or repair the equipment.

Pressure Air and Water

Pressurized air and/or water can cause debris and/or hot water to be blown out. This could result in personal injury.

When pressure air and/or pressure water is used for cleaning, wear protective clothing, protective shoes, and eye protection. Eye protection includes goggles or a protective face shield.

The maximum air pressure for cleaning purposes must be below 205 kPa (30 psi). The maximum water pressure for cleaning purposes must be below 275 kPa (40 psi).

Fluid Penetration

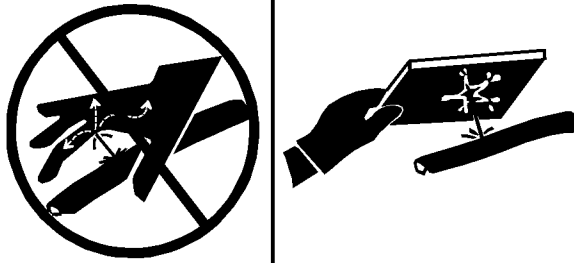

Illustration 6

g00687600

Always use a board or cardboard when you check for a leak. Leaking fluid that is under pressure can penetrate body tissue. Fluid penetration can cause serious injury and possible death. A pin hole leak can cause severe injury. If fluid is injected into your skin, you must get treatment immediately. Seek treatment from a doctor that is familiar with this type of injury.

Containing Fluid Spillage

Care must be taken in order to ensure that fluids are contained during performance of inspection, maintenance, testing, adjusting and repair of the engine. Prepare to collect the fluid with suitable containers before opening any compartment or disassembling any component containing fluids.

Refer to Special Publication, NENG2500, "Tools and Shop Products Guide" for the following items:

- Tools that are suitable for collecting fluids and equipment that is suitable for collecting fluids
- Tools that are suitable for containing fluids and equipment that is suitable for containing fluids

Obey all local regulations for the disposal of liquids.

Asbestos Information

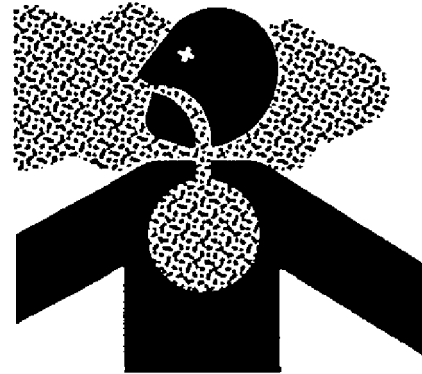

Illustration 7

g00702022

Caterpillar equipment and replacement parts that are shipped from Caterpillar are asbestos free. Caterpillar recommends the use of only genuine Caterpillar replacement parts. Use the following guidelines when you handle any replacement parts that contain asbestos or when you handle asbestos debris.

Use caution. Avoid inhaling dust that might be generated when you handle components that contain asbestos fibers. Inhaling this dust can be hazardous to your health. The components that may contain asbestos fibers are brake pads, brake bands, lining material, clutch plates, and some gaskets. The asbestos that is used in these components is usually bound in a resin or sealed in some way. Normal handling is not hazardous unless airborne dust that contains asbestos is generated.

If dust that may contain asbestos is present, there are several guidelines that should be followed:

- Never use compressed air for cleaning.
- Avoid brushing materials that contain asbestos.
- Avoid grinding materials that contain asbestos.
- Use a wet method in order to clean up asbestos materials.
- A vacuum cleaner that is equipped with a high efficiency particulate air filter (HEPA) can also be used.
- Use exhaust ventilation on permanent machining jobs.
- Wear an approved respirator if there is no other way to control the dust.

- Comply with applicable rules and regulations for the work place. In the United States, use Occupational Safety and Health Administration (OSHA) requirements. These OSHA requirements can be found in "29 CFR 1910.1001".
- Obey environmental regulations for the disposal of asbestos.
- Stay away from areas that might have asbestos particles in the air.

Dispose of Waste Properly

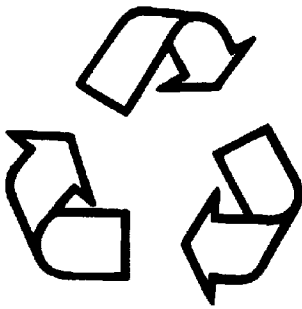

Illustration 8

g00706404

Improperly disposing of waste can threaten the environment. Potentially harmful fluids should be disposed of according to local regulations.

Always use leakproof containers when you drain fluids. Do not pour waste onto the ground, down a drain, or into any source of water.

i01480768

Burn Prevention

SMCS Code: 1000; 7405

Do not touch any part of an operating engine. Allow the engine to cool before any maintenance is performed on the engine. Relieve all pressure in the air system, in the hydraulic system, in the lubrication system, in the fuel system, or in the cooling system before any lines, fittings or related items are disconnected.

Coolant

When the engine is at operating temperature, the engine coolant is hot. The coolant is also under pressure. The radiator and all lines to the heaters or to the engine contain hot coolant.

Any contact with hot coolant or with steam can cause severe burns. Allow cooling system components to cool before the cooling system is drained.

Check the coolant level after the engine has stopped and the engine has been allowed to cool.

Ensure that the filler cap is cool before removing the filler cap. The filler cap must be cool enough to touch with a bare hand. Remove the filler cap slowly in order to relieve pressure.

Cooling system conditioner contains alkali. Alkali can cause personal injury. Do not allow alkali to contact the skin, the eyes, or the mouth.

Oils

Hot oil and hot lubricating components can cause personal injury. Do not allow hot oil to contact the skin. Also, do not allow hot components to contact the skin.

Batteries

Electrolyte is an acid. Electrolyte can cause personal injury. Do not allow electrolyte to contact the skin or the eyes. Always wear protective glasses for servicing batteries. Wash hands after touching the batteries and connectors. Use of gloves is recommended.

i01372254

Fire Prevention and Explosion Prevention

SMCS Code: 1000; 7405



Illustration 9

g00704000

All fuels, most lubricants, and some coolant mixtures are flammable.

Flammable fluids that are leaking or spilled onto hot surfaces or onto electrical components can cause a fire. Fire may cause personal injury and property damage.

A flash fire may result if the covers for the engine crankcase are removed within fifteen minutes after an emergency shutdown.

Determine whether the engine will be operated in an environment that allows combustible gases to be drawn into the air inlet system. These gases could cause the engine to overspeed. Personal injury, property damage, or engine damage could result.

If the application involves the presence of combustible gases, consult your Caterpillar dealer for additional information about suitable protection devices.

Remove all flammable materials such as fuel, oil, and debris from the engine. Do not allow any flammable materials to accumulate on the engine.

Store fuels and lubricants in properly marked containers away from unauthorized persons. Store oily rags and any flammable materials in protective containers. Do not smoke in areas that are used for storing flammable materials.

Do not expose the engine to any flame.

Exhaust shields (if equipped) protect hot exhaust components from oil or fuel spray in case of a line, a tube, or a seal failure. Exhaust shields must be installed correctly.

Do not weld on lines or tanks that contain flammable fluids. Do not flame cut lines or tanks that contain flammable fluid. Clean any such lines or tanks thoroughly with a nonflammable solvent prior to welding or flame cutting.

Wiring must be kept in good condition. All electrical wires must be properly routed and securely attached. Check all electrical wires daily. Repair any wires that are loose or frayed before you operate the engine. Clean all electrical connections and tighten all electrical connections.

Eliminate all wiring that is unattached or unnecessary. Do not use any wires or cables that are smaller than the recommended gauge. Do not bypass any fuses and/or circuit breakers.

Arcing or sparking could cause a fire. Secure connections, recommended wiring, and properly maintained battery cables will help to prevent arcing or sparking.

Inspect all lines and hoses for wear or for deterioration. The hoses must be properly routed. The lines and hoses must have adequate support and secure clamps. Tighten all connections to the recommended torque. Leaks can cause fires.

Oil filters and fuel filters must be properly installed. The filter housings must be tightened to the proper torque.



Illustration 10

g00704059

Use caution when you are refueling an engine. Do not smoke while you are refueling an engine. Do not refuel an engine near open flames or sparks. Always stop the engine before refueling.



Illustration 11

g00704135

Gases from a battery can explode. Keep any open flames or sparks away from the top of a battery. Do not smoke in battery charging areas.

Never check the battery charge by placing a metal object across the terminal posts. Use a voltmeter or a hydrometer.

Improper jumper cable connections can cause an explosion that can result in injury. Refer to the Operation Section of this manual for specific instructions.

Do not charge a frozen battery. This may cause an explosion.

The batteries must be kept clean. The covers (if equipped) must be kept on the cells. Use the recommended cables, connections, and battery box covers when the engine is operated.

Fire Extinguisher

Make sure that a fire extinguisher is available. Be familiar with the operation of the fire extinguisher. Inspect the fire extinguisher and service the fire extinguisher regularly. Obey the recommendations on the instruction plate.

Ether

Ether is flammable and poisonous.

Use ether in well ventilated areas. Do not smoke while you are replacing an ether cylinder or while you are using an ether spray.

Do not store ether cylinders in living areas or in the engine compartment. Do not store ether cylinders in direct sunlight or in temperatures above 49 °C (120 °F). Keep ether cylinders away from open flames or sparks.

Dispose of used ether cylinders properly. Do not puncture an ether cylinder. Keep ether cylinders away from unauthorized personnel.

Do not spray ether into an engine if the engine is equipped with a thermal starting aid for cold weather starting.

Lines, Tubes and Hoses

Do not bend high pressure lines. Do not strike high pressure lines. Do not install any lines that are bent or damaged.

Repair any lines that are loose or damaged. Leaks can cause fires. Consult your Caterpillar dealer for repair or for replacement parts.

Check lines, tubes and hoses carefully. Do not use your bare hand to check for leaks. Use a board or cardboard to check for leaks. Tighten all connections to the recommended torque.

Replace the parts if any of the following conditions are present:

- End fittings are damaged or leaking.
- Outer coverings are chafed or cut.
- Wires are exposed.
- Outer coverings are ballooning.
- Flexible part of the hoses are kinked.
- Outer covers have embedded armoring.
- End fittings are displaced.

Make sure that all clamps, guards, and heat shields are installed correctly. During engine operation, this will help to prevent vibration, rubbing against other parts, and excessive heat.

i01359666

Crushing Prevention and Cutting Prevention

SMCS Code: 1000; 7405

Support the component properly when work beneath the component is performed.

Unless other maintenance instructions are provided, never attempt adjustments while the engine is running.

Stay clear of all rotating parts and of all moving parts. Leave the guards in place until maintenance is performed. After the maintenance is performed, reinstall the guards.

Keep objects away from moving fan blades. The fan blades will throw objects or cut objects.

When objects are struck, wear protective glasses in order to avoid injury to the eyes.

Chips or other debris may fly off objects when objects are struck. Before objects are struck, ensure that no one will be injured by flying debris.

i01372247

i00910470

Mounting and Dismounting

SMCS Code: 1000; 7405

Inspect the steps, the handholds, and the work area before mounting the engine. Keep these items clean and keep these items in good repair.

Mount the engine and dismount the engine only at locations that have steps and/or handholds. Do not climb on the engine, and do not jump off the engine.

Face the engine in order to mount the engine or dismount the engine. Maintain a three-point contact with the steps and handholds. Use two feet and one hand or use one foot and two hands. Do not use any controls as handholds.

Do not stand on components which cannot support your weight. Use an adequate ladder or use a work platform. Secure the climbing equipment so that the equipment will not move.

Do not carry tools or supplies when you mount the engine or when you dismount the engine. Use a hand line to raise and lower tools or supplies.

i00911989

Before Starting Engine

SMCS Code: 1000

Inspect the engine for potential hazards.

Before starting the engine, ensure that no one is on, underneath, or close to the engine. All protective guards and all protective covers must be installed if the engine must be started in order to perform service procedures. To help prevent an accident that is caused by parts in rotation, work around the parts carefully.

Do not bypass the automatic shutoff circuits. Do not disable the automatic shutoff circuits. The circuits are provided in order to help prevent personal injury. The circuits are also provided in order to help prevent engine damage.

On the initial start-up of a new engine or an engine that has been serviced, prepare to stop the engine if an overspeed condition occurs. This may be accomplished by shutting off the fuel supply to the engine and/or shutting off the air supply to the engine.

See the Service Manual for repairs and for adjustments.

Engine Starting

SMCS Code: 1000

If a warning tag is attached to the engine start switch or to the controls, do not start the engine or move the controls. Also, do not disengage the parking brakes. Consult with the person that attached the warning tag before the engine is started.

All protective guards and all protective covers must be installed if the engine must be started in order to perform service procedures. To help prevent an accident that is caused by parts in rotation, work around the parts carefully.

Start the engine from the operator's station (cab). Never short across the starting motor terminals or the batteries. This could bypass the engine neutral start system and/or the electrical system could be damaged.

Always start the engine according to the procedure that is described in the Operation and Maintenance Manual, "Engine Starting" topic (Operation Section). Knowing the correct procedure will help to prevent major damage to the engine components. Knowing the procedure will also help to prevent personal injury.

To ensure that the jacket water heater (if equipped) and/or the lube oil heater (if equipped) is working properly, check the water temperature gauge and the oil temperature gauge during the heater operation.

Engine exhaust contains products of combustion that can be harmful to your health. Always start the engine and operate the engine in a well ventilated area. If the engine is started in an enclosed area, vent the engine exhaust to the outside.

Ether

Ether is poisonous and flammable. Do not inhale ether, and do not allow ether to contact the skin. Personal injury could result. Do not smoke while ether cylinders are changed. Use ether in well ventilated areas.

Keep ether cylinders out of the reach of unauthorized persons. Store ether cylinders in authorized storage areas only. Do not store ether cylinders in direct sunlight or at temperatures above 39 °C (102 °F). Discard the ether cylinders in a safe place. Do not puncture the ether cylinders. Do not burn the ether cylinders.

i01462046

Grounding Practices

Engine Stopping

SMCS Code: 1000

Stop the engine according to the procedure in the Operation and Maintenance Manual, "Engine Stopping (Operation Section)" in order to avoid overheating of the engine and accelerated wear of the engine components.

Use the Emergency Stop Button (if equipped) ONLY in an emergency situation. Do not use the Emergency Stop Button for normal engine stopping. After an emergency stop, DO NOT start the engine until the problem that caused the emergency stop has been corrected.

Stop the engine if an overspeed condition occurs during the initial start-up of a new engine or an engine that has been overhauled. This may be accomplished by shutting off the fuel supply to the engine and/or shutting off the air supply to the engine.

To stop an electronically controlled engine, cut the power to the engine.

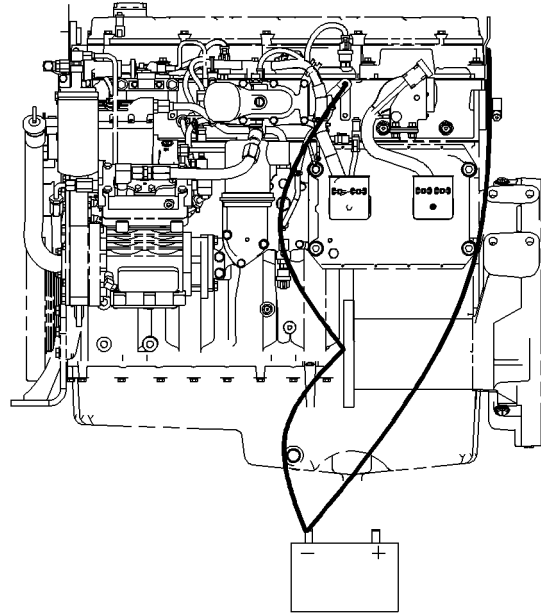

i01489749

Electrical System

SMCS Code: 1000; 1400

Never disconnect any charging unit circuit or battery circuit cable from the battery when the charging unit is operating. A spark can cause the combustible gases that are produced by some batteries to ignite.

To help prevent sparks from igniting combustible gases that are produced by some batteries, the negative "-" jump start cable should be connected last from the external power source to the negative "-" terminal of the starting motor. If the starting motor is not equipped with a negative "-" terminal, connect the jump start cable to the engine block.

Check the electrical wires daily for wires that are loose or frayed. Tighten all loose electrical wires before the engine is started. Repair all frayed electrical wires before the engine is started. See the Operation and Maintenance Manual for specific starting instructions.

Illustration 12

g00774062

Typical example
Grounding Stud To Battery Ground

Engine Electronics

SMCS Code: 1000; 1400; 1900

WARNING

Tampering with the electronic system installation or the OEM wiring installation can be dangerous and could result in personal injury or death and/or engine damage.

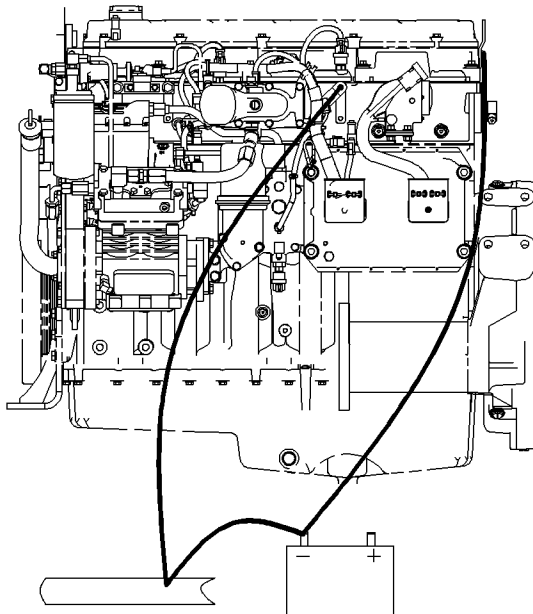

Illustration 13

g00774088

Typical example

Alternate Grounding Stud To Battery Ground

Proper grounding for the engine electrical system is necessary for optimum engine performance and reliability. Improper grounding will result in uncontrolled electrical circuit paths and in unreliable electrical circuit paths.

Uncontrolled electrical circuit paths can result in damage to main bearings, to crankshaft bearing journal surfaces, and to aluminum components.

Engines that are installed without engine-to-frame ground straps can be damaged by electrical discharge.

To ensure that the engine and the engine electrical systems function properly, an engine-to-frame ground strap with a direct path to the battery must be used. This path may be provided by way of a starting motor ground, a starting motor ground to the frame, or a direct engine ground to the frame.

All grounds should be tight and free of corrosion. The engine alternator must be grounded to the negative “-” battery terminal with a wire that is adequate to handle the full charging current of the alternator.

This engine has a comprehensive, programmable Engine Monitoring System. The Engine Control Module (ECM) has the ability to monitor the engine operating conditions. If any of the engine parameters extend outside an allowable range, the ECM will initiate an immediate action.

The following actions are available for engine monitoring control: WARNING, DERATE, and SHUTDOWN. These engine monitoring modes have the ability to limit engine speed and/or the engine power.

Many of the parameters that are monitored by the ECM can be programmed for the engine monitoring functions. The following parameters can be monitored as a part of the Engine Monitoring System:

- Operating Altitude
- Engine Coolant Level
- Engine Coolant Temperature
- Engine Oil Pressure
- Engine Speed
- Fuel Temperature
- Intake Manifold Air Temperature
- System Voltage

The Engine Monitoring package can vary for different engine models and different engine applications. However, the monitoring system and the engine monitoring control will be similar for all engines.

Note: Many of the engine control systems and display modules that are available for Caterpillar Engines will work in unison with the Engine Monitoring System. Together, the two controls will provide the engine monitoring function for the specific engine application. Refer to the Electronic Troubleshooting Manual for more information on the Engine Monitoring System.

Product Information Section

General Information

Welding on Engines with Electronic Controls

i01456258

SMCS Code: 1000

NOTICE

Because the strength of the frame may decrease, some manufacturers do not recommend welding onto a chassis frame or rail. Consult the OEM of the equipment or your Caterpillar dealer regarding welding on a chassis frame or rail.

Proper welding procedures are necessary in order to avoid damage to the engine's ECM, sensors, and associated components. When possible, remove the component from the unit and then weld the component. If removal of the component is not possible, the following procedure must be followed when you weld on a unit that is equipped with a Caterpillar Electronic Engine. The following procedure is considered to be the safest procedure to weld on a component. This procedure should provide a minimum risk of damage to electronic components.

NOTICE

Do not ground the welder to electrical components such as the ECM or sensors. Improper grounding can cause damage to the drive train bearings, hydraulic components, electrical components, and other components.

Clamp the ground cable from the welder to the component that will be welded. Place the clamp as close as possible to the weld. This will help reduce the possibility of damage.

1. Stop the engine. Turn the switched power to the OFF position.
2. Disconnect the negative battery cable from the battery. If a battery disconnect switch is provided, open the switch.
3. Disconnect the J1/P1 and J2/P2 connectors from the ECM. Move the harness to a position that will not allow the harness to accidentally move back and make contact with any of the ECM pins.

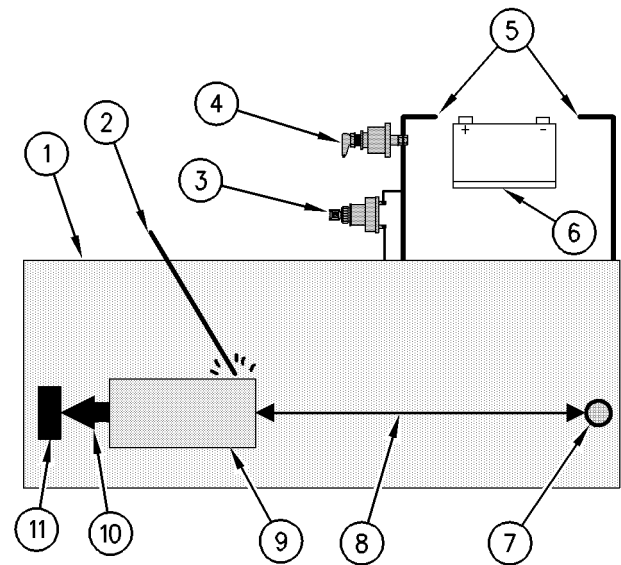

Illustration 14

g00765012

Use the example above. The current flow from the welder to the ground clamp of the welder will not cause damage to any associated components.

- (1) Engine
- (2) Welding rod
- (3) Keyswitch in the OFF position
- (4) Battery disconnect switch in the open position
- (5) Disconnected battery cables
- (6) Battery
- (7) Electrical/Electronic component
- (8) Maximum distance between the component that is being welded and any electrical/electronic component
- (9) The component that is being welded
- (10) Current path of the welder
- (11) Ground clamp for the welder

4. Connect the welding ground cable directly to the part that will be welded. Place the ground cable as close as possible to the weld in order to reduce the possibility of welding current damage to bearings, hydraulic components, electrical components, and ground straps.

Note: If electrical/electronic components are used as a ground for the welder, or electrical/electronic components are located between the welder ground and the weld, current flow from the welder could severely damage the component.

5. Protect the wiring harness from welding debris and spatter.
6. Use standard welding practices to weld the materials.

Model Views

i01474848

Model View Illustrations

SMCS Code: 1000

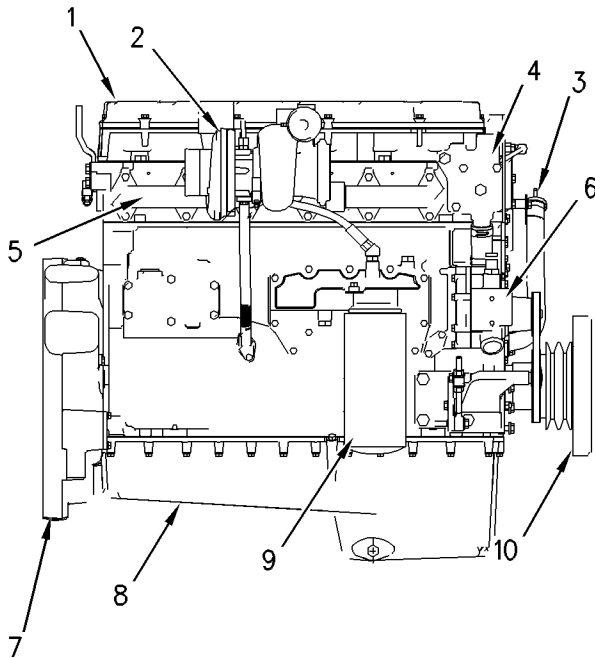

Illustration 15

g00770182

Right Side View

- (1) Valve mechanism cover
- (2) Turbocharger
- (3) Engine oil filler cap
- (4) Water temperature regulator housing
- (5) Exhaust manifold
- (6) Water pump
- (7) Flywheel housing
- (8) Engine oil pan
- (9) Engine oil filter
- (10) Vibration damper and crankshaft pulley

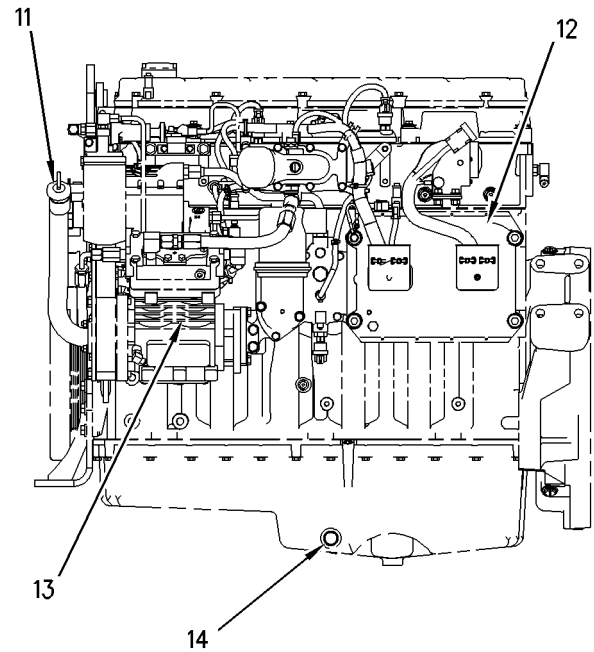

Illustration 16

g00774521

Left Side View

- (11) Engine oil filler
- (12) Electronic Control Module (ECM)
- (13) Air compressor
- (14) Oil drain plug

Engine Description

SMCS Code: 1000

The Caterpillar C-9 Industrial Engine has the following characteristics:

- In-Line 6 cylinder
- Four stroke cycle
- Hydraulically Actuated Electronic Unit Injection (HEUI)
- Turbocharged
- Air-to-air aftercooled

Engine Specifications

Note: The front end of the engine is opposite the flywheel end of the engine. The left and the right sides of the engine are determined from the flywheel end. The number 1 cylinder is the front cylinder.

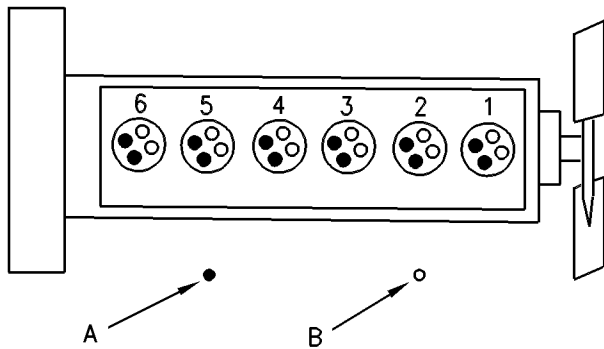

Illustration 17

g00609479

Cylinder and valve location

(A) Exhaust valve
(B) Inlet valve

Table 1

C-9 Engine Specifications	
Arrangement and Cylinders	In-Line 6 cylinder
Bore	112.0 mm (4.41 inch)
Stroke	149.0 mm (5.87 inch)
Aspiration	ATAAC ⁽¹⁾
Displacement	8.8 L (537 in ³)
Firing Order	1-5-3-6-2-4
Rotation (flywheel end)	Counterclockwise
Valve Lash (inlet)	0.38 mm (0.015 inch)
Valve Lash (exhaust)	0.64 mm (0.025 inch)

⁽¹⁾ Air-to-air aftercooled

Electronic Engine Features

The Caterpillar C-9 Engine is designed for electronic controls. The integral on board computer controls the operation of the engine. Current operating conditions are monitored. The Electronic Control Module (ECM) controls the response of the engine to these conditions and to the demands of the operator. These conditions and operator demands determine the precise control of fuel injection by the ECM. The electronic engine control system provides the following features:

- Engine speed governor
- Automatic air/fuel ratio control
- Torque rise shaping
- Injection timing control
- System diagnostics

For more information on electronic engine features, refer to the Operation and Maintenance Manual, “Engine Features and Controls” topic (Operation Section).

Additional Features

The following additional features provide increased engine fuel economy and serviceability:

- Cold starting capability
- Tampering detection
- Diagnostics

Hydraulic Electronic Unit Injectors

Hydraulically Actuated Electronic Unit Injectors (HEUI) perform the following functions:

- Pump the fuel.
- Meter the fuel.
- Time the fuel injection.

The unit injectors are controlled by the ECM which uses the camshaft position and the engine speed signals from the engine speed/timing sensors and the inlet air pressure sensors. The engine’s rated rpm is identified on the Information Plate.

Engine Diagnostics

The engine has built-in diagnostics in order to ensure that all of the components are functioning properly. In the event of a deviation from the programmed limits, the operator will be alerted to the condition by a “DIAGNOSTIC” lamp that is mounted on the dashboard. Under certain conditions, the engine horsepower and the vehicle speed may be limited. A Caterpillar electronic service tool may be used to display the diagnostic code.

There are three types of diagnostic codes: active, logged, and event.

Most of the diagnostic codes are logged and stored in the ECM. For additional information, refer to the Operation and Maintenance Manual, “Engine Diagnostics” topic (Operation Section).

The ECM provides an electronic governor that controls the injector output in order to maintain the desired engine rpm. The functionality of electronic governor is similar to the Caterpillar mechanical governor, but the electronic governor includes additional features.

Engine Cooling and Lubrication

The cooling system consists of the following components:

- Centrifugal pump that is driven by belts
- Water temperature regulator which regulates the engine coolant temperature
- Oil cooler and radiator which incorporates a shunt system

The engine lubricating oil that is supplied is cooled. The engine lubricating oil is also filtered. Bypass valves provide unrestricted flow of lubrication oil to the engine components during the following conditions:

- High oil viscosity
- Plugged oil cooler or plugged oil filter elements (paper cartridge)

Engine Service Life

Engine efficiency and maximum utilization of engine performance depend on the adherence to proper operation and maintenance recommendations. In addition, use recommended fuels, coolants and lubricants. Use the Operation and Maintenance Manual as a guide for required engine maintenance.

Expected engine life is generally predicted by the average power that is demanded. The average power that is demanded is based on fuel consumption of the engine over a period of time. Reduced hours of operation at full throttle and/or operating at reduced throttle settings result in a lower average power demand. Reduced hours of operation will increase the length of operating time before an engine overhaul is required. For more information, refer to the Operation and Maintenance Manual, "Overhaul Considerations" topic (Maintenance Section).

Aftermarket Products and Caterpillar Engines

NOTICE

In order to maximize fuel system life and prevent premature wear out from abrasive particles in the fuel, a two micron absolute high efficiency fuel filter is required for all Caterpillar Electronic Unit Injectors. Caterpillar High Efficiency Fuel Filters meet these requirements. Consult your Caterpillar dealer for the proper part numbers.

When auxiliary devices, accessories, or consumables (filters, additives, catalysts, etc) which are made by other manufacturers are used on Caterpillar products, the Caterpillar warranty is not affected simply because of such use.

However, failures that result from the installation or use of other manufacturers' devices, accessories, or consumables are NOT Caterpillar defects. Therefore, the defects are NOT covered under the Caterpillar warranty.

Welding and Caterpillar Electronic Engines

NOTICE

Because the strength of the frame may decrease, some manufacturers do not recommend welding onto a chassis frame or rail. Consult the OEM of the equipment or your Caterpillar dealer regarding welding on a chassis frame or rail.

To help avoid damage to the electronic controls, proper welding procedures are necessary. Before welding on an engine that is equipped with an electronic engine, observe the following precautions:

1. Turn off the engine. Place the key start switch in the OFF position.
 2. If the machine has a battery disconnect switch, open the switch. Otherwise, disconnect the negative "-" battery cable from the battery of the vehicle.
-

NOTICE

Do not ground the welder to electrical components such as the ECM or sensors. Improper grounding can cause damage to the drive train bearings, hydraulic components, electrical components, and other components.

Clamp the ground cable from the welder to the component that will be welded. Place the clamp as close as possible to the weld. This will help reduce the possibility of damage.

3. Clamp the ground cable from the welder to the component that will be welded. Place the clamp as close as possible to the weld.
4. Protect wiring harnesses from welding debris and spatter. Use proper welding procedures.

i01484593

Product Identification Information

Information Plate

SMCS Code: 1000

i01028428

Engine Identification

SMCS Code: 1000

Caterpillar engines are identified with serial numbers, with performance specification numbers, and with arrangement numbers. In some of the cases, modification numbers are used. These numbers are shown on the Serial Number Plate and the Information Plate that are mounted on the engine.

Caterpillar dealers need these numbers in order to determine the components that were included with the engine. This permits accurate identification of replacement part numbers.

CAT		ENGINE MODEL			
SER. NO.	MODEL/POWER			—	
MODIFICATION NO.				MAX	M
AR NO.	PERF SPEC			ALT	FT
DEM NO.					
FUEL LOAD	FULL TORQ.				
STATIC FUEL	STATIC FUEL				
RATED	HP	kw AT	RPM	BARE	ENG.
FUEL	A/F RATIO DYNAMIC		HIGH IDLE		
TIMING			RPM		

Illustration 19

g00764335

The Information Plate is on the valve cover. The following information is on the Information Plate: engine serial number, engine model, engine arrangement number, maximum altitude of the engine that is necessary to achieve the rated power, horsepower, high idle, full load rpm, fuel settings, and other information.

i01461841

Serial Number Plate

SMCS Code: 1000

CATERPILLAR		CAT	
SERIAL NUMBER		ARRANGE- MENT NUMBER	
ENGINE MODEL			
MADE IN U.S.A.		(ALWAYS GIVE ALL NUMBERS)	

Illustration 18

g00764267

The Serial Number Plate is located on the right side of the cylinder block near the rear of the engine.

The following information is stamped on the Serial Number Plate: engine serial number, engine model, and arrangement number.

Reference Numbers

SMCS Code: 1000

Information for the following items may be needed to order parts. Locate the information for your engine. Record the information on the appropriate space. Make a copy of this list for a record. Retain the information for future reference.

Record for Reference

Engine Model _____

Engine Serial No. _____

Engine Arrangement No. _____

Modification No. _____

Engine Low Idle rpm _____

Engine Full Load rpm _____

Performance Specification No. _____

Primary Fuel Filter No. _____

Water Separator Element No. _____

i00610276

Secondary Fuel Filter Element No. _____

Lubrication Oil Filter Element No. _____

Auxiliary Oil Filter Element No. _____

Supplemental Coolant Additive Maintenance
Element No. (Optional) _____

Total Lubrication System Capacity _____

Total Cooling System Capacity _____

Air Cleaner Element No. _____

Fan Drive Belt No. _____

Alternator Belt No. _____

i01542360

Emissions Certification Film

SMCS Code: 1000; 7405

Note: This information is pertinent in the United States and in Canada.

A typical example is shown.

CATERPILLAR INC.		IMPORTANT ENGINE INFORMATION			2000	JDM00001
 ENGINE MODEL : 3116 - DISPLACEMENT : 6.6L - VALVE LASH : 0.38mm INTAKE 0.64mm EXHAUST						
ENGINE FAMILY XCPXL06 6MFB	MAXIMUM ADVERTISED KW (HP) 164 (220)	MAXIMUM RATED SPEED (RPM) 2600	MAXIMUM LOW IDLE SPEED (RPM) 875	MAX. FUEL RATE @MAXIMUM (mm ³ /STROKE) 104	MAXIMUM INITIAL TIMING DEGREES BTDC 11.5	EXHAUST EMISSION CONTROL SYSTEM EM,DI,TC,SPL,CAC
THIS 3116 ENGINE CONFORMS TO DIRECTIVE 97/68/EC FOR NON-ROAD ENGINES.				EC TYPE APPROVAL NO. eIRL*97/68AA*0001*00		
THIS 3116 ENGINE CONFORMS TO 2000 U.S. EPA AND CALIFORNIA REGULATIONS LARGE NON-ROAD COMPRESSION-IGNITION ENGINES.						
THIS ENGINE IS CERTIFIED TO OPERATE ON COMMERCIALY AVAILABLE DIESEL FUEL.						
DATE OF MANUFACTURE MONTH : 08						7E-8050 01

FMT:3500

The EPA/EU Emissions Certification Film (if applicable) is located either on the side, the top, or the front of the engine.

CATERPILLAR INC.		INFORMATION IMPORTANTE SUR LE MOTEUR				
 MODÈLE MOTEUR : 3116 - DÉBIT : 6,6 l - JEU SOUPAPES : 0,38 mm ADMISSION : 0,64 mm ÉCHAPPEMENT						
FAMILLE DE MOTEURS : XCPXL06 6MFB	Kw (HP) MAXI PUBLIES : 164 (220)	MAXI RÉGIME NOMINAL (tr/min) : 2600	MAXI RÉGIME RALENTI (tr/min) : 875	MAXI DÉBIT D'INJ. A PUIS: MAXI (mm ³ /STROKE) (PISTON) : 104	MAXI CALAGE INITIAL D'INJ. (DEGRÉS) (AVANT PMH) : 11,5	DISPOSITIF ANTI-POLLUANT : FM,DI,TC,SPL,CAC
CE MOTEUR 3116 EST CONFORME AUX DIRECTIVES 97/68/EC POUR LES MOTEURS NON ROUTIERS.				NO APPROBATION TYPE EC eIRL*97/68AA*0001*00		
CE MOTEUR 3116 EST CONFORME AUX RÉGLEMENTATIONS 2000 DE L'AGENCE AMÉRICAINE DE PROTECTION DE L'ENVIRONNEMENT (EPA) ET DE LA CALIFORNIE POUR LES GROS MOTEURS NON ROUTIERS À COMPRESSION-CONTACT.						
CE MOTEUR EST HOMOLOGUÉ POUR FONCTIONNER AVEC LE CARBURANT DIESEL DU COMMERCE.						
DATE DE FABRICATION (MOIS) : 08						

Étiquette d'homologation anti-pollution

L'autocollant d'homologation du dispositif antipollution EPA/EU (selon équipement) est situé soit sur le côté du moteur, soit sur le dessus du moteur, soit sur le devant du moteur.

Illustration 20

g00776690

i00811683

Customer Specified Parameters

SMCS Code: 1000

To record programmed specifications, use the following blanks.

Customer Passwords

- First Password _____
- Second Password _____

Power Rating (hp at rpm) _____

Rating Selection (A-E) _____

Air/Fuel Ratio

- Level 1: Minimal Smoke _____
- Level 2: Optimum Performance _____
- Level 3: Maximum Acceleration _____

PTO Governor Parameters

- PTO Engine Speed Ramp Rate _____ rpm/sec

Engine Parameters

- Top Engine Limit (TEL) at 100 percent load (If Applicable) _____

- Torque Limit _____
- High Idle (If Applicable) _____
- Low Idle _____
- Intermediate Speed _____

Engine Monitoring Mode

- “OFF” _____
- “Warning” _____
- “Warning/Derate” _____
- “Warning/Derate/Shutdown” _____
- “Coolant Level Sensor Enable/Disable” _____
- “Fuel Pressure Sensor Enable/Disable” _____
- “Inlet Manifold Air Temperature Sensor Enable/Disable” _____

Equipment ID

Maintenance Indicator

- Manual-Hours
- Auto-Hours
- Manual-Fuel
- Auto-Fuel

Auxiliary Pressure

- High Warning Set Point _____

Auxiliary Temperature

- High Warning Set Point _____

Operation Section

Engine Lifting and Storage

i01028344

Engine Lifting

SMCS Code: 1000; 1122

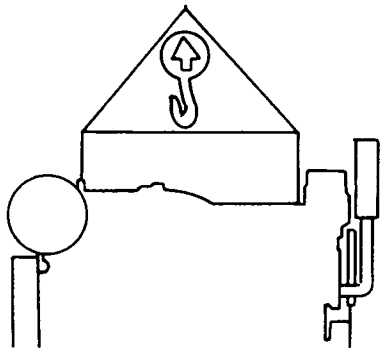

Illustration 21

g00103219

NOTICE

Never bend the eyebolts and the brackets. Only load the eyebolts and the brackets under tension. Remember that the capacity of an eyebolt is less as the angle between the supporting members and the object becomes less than 90 degrees.

When it is necessary to remove a component at an angle, only use a link bracket that is properly rated for the weight.

Use a hoist to remove heavy components. Use an adjustable lifting beam to lift the engine. All supporting members (chains and cables) should be parallel to each other. The chains and cables should be perpendicular to the top of the object that is being lifted.

Some removals require lifting the fixtures in order to obtain proper balance and safety.

To remove the engine ONLY, use the lifting eyes that are on the engine.

Lifting eyes are designed and installed for the specific engine arrangement. Alterations to the lifting eyes and/or the engine make the lifting eyes and the lifting fixtures obsolete. If alterations are made, ensure that proper lifting devices are provided. Consult your Caterpillar dealer for information regarding fixtures for proper engine lifting.

Engine Storage

SMCS Code: 1000

If the engine will not be started for several weeks, the lubricating oil will drain from the cylinder walls and from the piston rings. Rust can form on the cylinder liner surface. Rust on the cylinder liner surface will cause increased engine wear and a reduction in engine service life.

To help prevent excessive engine wear, use the following guidelines:

- Complete all of the lubrication recommendations that are listed in this Operation and Maintenance Manual, "Maintenance Interval Schedule" (Maintenance Section).
- If freezing temperatures are expected, check the cooling system for adequate protection against freezing. See this Operation and Maintenance Manual, "General Coolant Information" (Maintenance Section).

If an engine is out of operation and if use of the engine is not planned, special precautions should be made. If the engine will be stored for more than one month, a complete protection procedure is recommended.

For more detailed information on engine storage, see Special Instruction, SEHS9031, "Storage Procedure For Caterpillar Products".

Your Caterpillar dealer can assist in preparing the engine for extended storage periods.

Gauges and Indicators

i01465281

Gauges and Indicators

SMCS Code: 1900; 7450

Your engine may not have the same gauges or all of the gauges that are described. For more information about the gauge package, see the literature that is provided by the OEM.

Gauges provide indications of engine performance. Ensure that the gauges are in good working order. Determine the normal operating range by observing the gauges over a period of time.

Noticeable changes in gauge readings indicate potential gauge or engine problems. Problems may also be indicated by gauge readings that change even if the readings are within specifications. Determine the cause of any significant change in the readings. Then, correct any cause of any significant change in the readings. Consult your Caterpillar dealer for assistance.

Caterpillar requires one lamp in addition to the gauge package that is normally provided. The “Diagnostic” lamp is yellow or amber. The “Diagnostic” lamp will communicate the status of the engine’s electronic system. The optional red “Warning” lamp is also available. This red “Warning” lamp warns the operator of engine problems.

The following conditions are some examples of the engine problems:

- Low oil pressure
- High coolant temperature
- Low coolant level
- High inlet air temperature



Engine Oil Pressure – Typical oil pressure for an engine at rated speed with SAE 10W30 or with SAE 15W40 is 240 to 480 kPa (35 to 70 psi).

A lower oil pressure is normal at low idle. If the load is stable and the gauge reading changes, perform the following procedure:

1. Remove the load.
2. Reduce engine speed to low idle.

3. Check the oil level. Maintain the oil level at the proper amount.

If the gauge continues to fluctuate, consult your Caterpillar dealer.

The diagnostic lamp will turn on if the oil pressure drops below 35 kPa (5 psi) at low idle rpm. The diagnostic code will be logged in the Engine Control Module (ECM).



Engine Oil Temperature – This gauge indicates the engine oil temperature. An oil temperature that is higher than normal indicates a heat problem in the lubrication system and/or the cooling system. This problem can damage the cylinder heads, the cylinder liners, the pistons, and the crankshaft bearings.



Jacket Water Coolant Temperature – Typical temperature range is 88 to 102 °C (190 to 215 °F). The maximum allowable temperature with the pressurized cooling system is 105 °C (220 °F). Higher temperatures may occur under certain conditions. The water temperature reading may vary according to load. The reading should never exceed the boiling point for the pressurized system that is being used.

If the engine is operating above the normal range or steam becomes apparent, perform the following procedure:

1. Reduce the load and the engine rpm.
2. Inspect the cooling system for leaks.
3. Determine if the engine must be shut down immediately or if the engine can be cooled by reducing the load.

WARNING

Pressurized System: Hot coolant can cause serious burns. To open the cooling system filler cap, stop the engine and wait until the cooling system components are cool. Loosen the cooling system pressure cap slowly in order to relieve the pressure.

4. Check the coolant level.



Tachometer – This gauge indicates engine speed. When the throttle control lever is moved to the full throttle position without load, the engine is running at high idle. The engine is running at the full load rpm when the throttle control lever is at the full throttle position with maximum rated load.

Note: The default high idle rpm and the full load rpm are stamped on the Information Plate.



Ammeter – This gauge indicates the amount of charge or of discharge in the battery charging circuit. Operation of the indicator should be to the right side of “0”(zero).



Service Hour Meter – This gauge indicates the total number of clock hours of engine operation. Hours of operation are logged in the ECM. A service tool is needed to retrieve the hours from the ECM. A Service Hour Meter may be installed on the engine.



Fuel Pressure – This gauge indicates fuel pressure to the electronic unit injectors from the fuel filter. The indicator should indicate the “NORMAL” range. A decrease in fuel pressure usually indicates a plugged fuel filter.



Fuel Level – This gauge indicates the level of fuel in the fuel tank. The fuel level gauge registers the fuel level only when the ignition switch is in the ON position.

i01518477

Engine Monitoring System (EMS)

SMCS Code: 7490

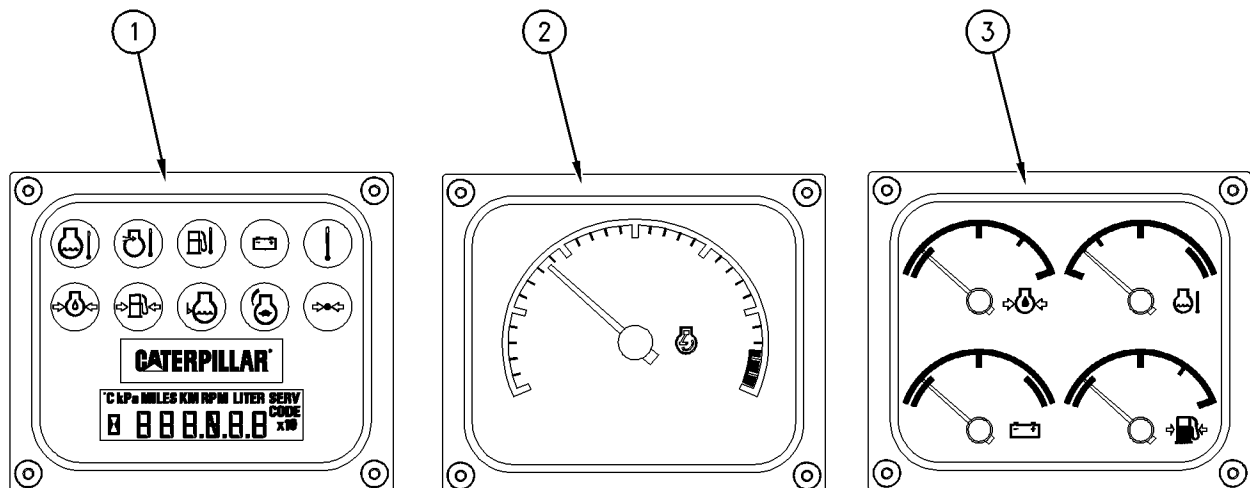

Illustration 22

(1) Main unit

(2) Tachometer (unit)

(3) Quad gauge

g00788015

The Caterpillar Engine Monitoring System (EMS) is an option. The engine parameters are displayed in both digital display and analog. The EMS display is for electronically controlled engines.

The EMS includes three individual gauge units. The units can be installed in various combinations. The main unit must be used if any of the units are used.

Refer to the EMS Operator's Guide, LEXH7530 for additional information. For information on installation and troubleshooting, refer to Installation Guide, SENR1025.

EMS Main Unit

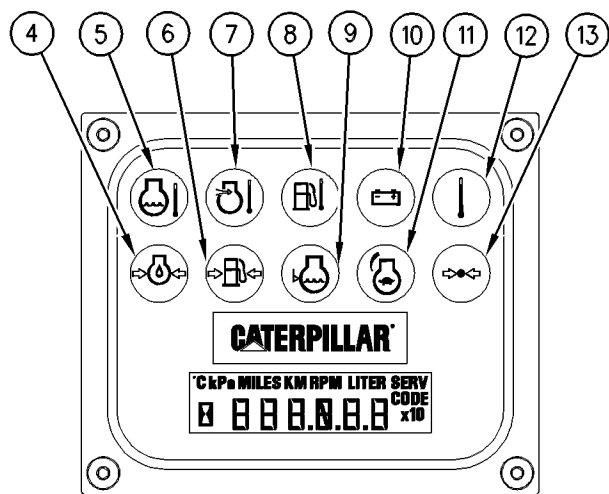

Illustration 23

g00595165

- (4) Engine oil pressure
- (5) Engine coolant temperature
- (6) Fuel pressure
- (7) Inlet manifold temperature
- (8) Fuel temperature
- (9) Engine coolant level
- (10) Battery voltage
- (11) Active engine derate
- (12) Auxiliary temperature
- (13) Auxiliary pressure

The Engine Monitoring System provides warning lamps. Refer to Illustration 23. The Engine Monitoring System provides a LCD display for engine parameters. When the scroll switch is depressed, the parameters will scroll on the screen. The EMS displays the real time value for the parameter that is selected. The default is engine speed.

The parameters are abbreviated on the LCD display. Table 2 lists the parameters.

Table 2

Abbreviation	Parameter
Spd	Engine Speed
GA-1	Engine Oil Pressure
GA-2	Coolant Temperature
GA-3	Battery Voltage
GA-4	Fuel Pressure
Boost	Boost Pressure
IAirT	Inlet Air Temperature
FuelT	Fuel Temperature
AccrP	Auxiliary Pressure
AccrT	Auxiliary Temperature
Fuel	Fuel Rate
Hrs	Engine Hours
Load	Percent of Engine Load (speed and derate)

Note: For detailed information on the exact parameters for your engine, refer to the Operation and Maintenance Manual, "Gauges and Indicators".

Quad Gauge Unit

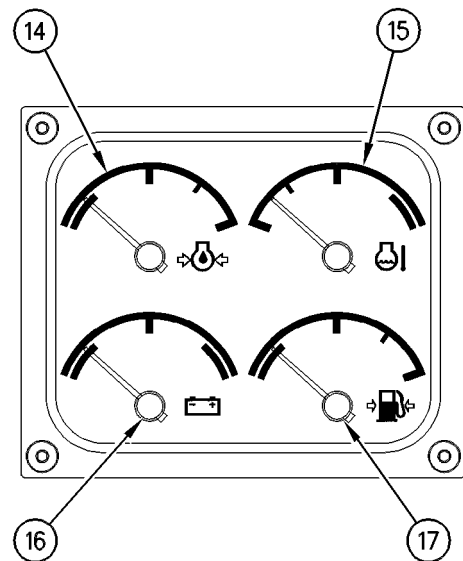

Illustration 24

g00595166

- (14) Engine oil pressure
- (15) Engine coolant temperature
- (16) Battery voltage
- (17) Fuel pressure

The quad gauge unit displays the following information: engine oil pressure, engine coolant temperature, battery voltage, and fuel pressure

Note: The gauge needles may not always return to zero position when the engine is not running.

Note: For detailed information on the exact parameters for your engine, refer to the Operation and Maintenance Manual, “Gauges and Indicators”.

Tachometer Unit

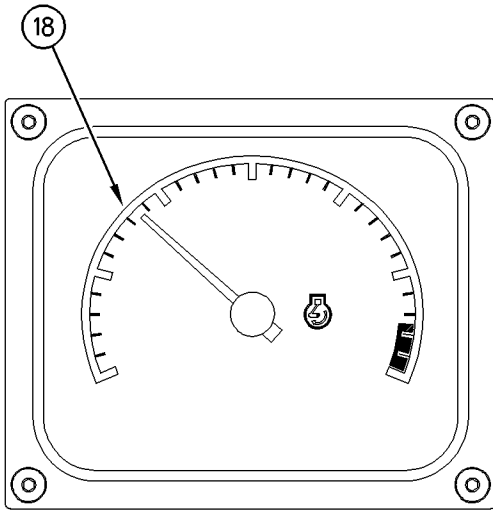

Illustration 25
(18) Tachometer

g00788023

The tachometer displays the engine speed (rpm) on an analog gauge.

Note: For detailed information on the exact parameters for your engine, refer to the Operation and Maintenance Manual, “Gauges and Indicators”.

Communication Data Link

The EMS provides two pins that are connected to the data link. The data link is available to share data with other modules. The ECM processes engine parameters. The parameters will then be transmitted to the EMS through the data link. The EMS receives the information. The information is then displayed on various gauges.

For additional information, refer to the Troubleshooting Manual, “Cat Data Link Circuit-Test”.

Engine Features and Controls

i01503649

Sensors and Electrical Components

SMCS Code: 1900; 7400

Sensor Locations

Illustration 26 shows the typical locations of the sensors for a C-9 Industrial Engine. Specific engines may appear different from the illustration due to differences in applications.

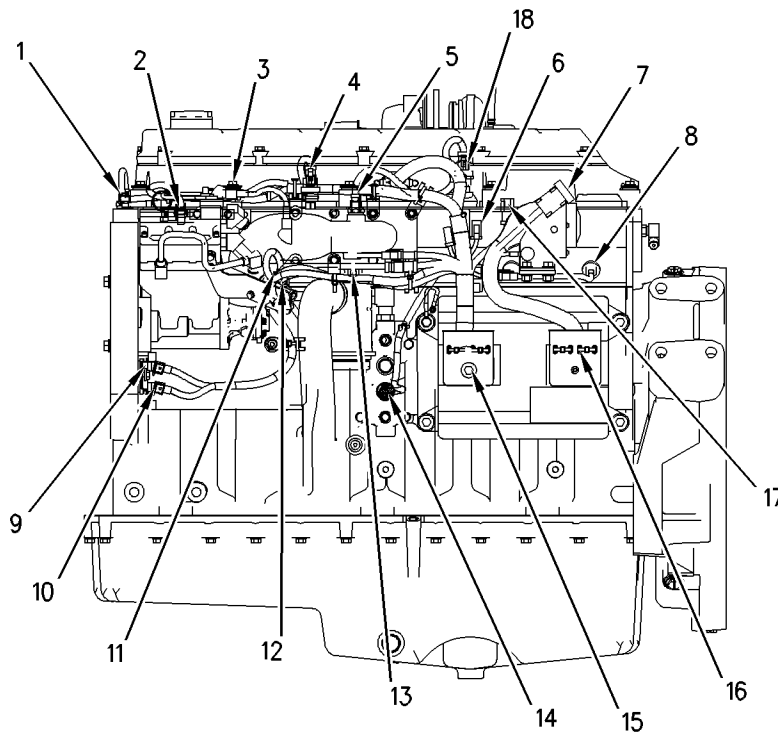

Illustration 26

g00779441

- | | | |
|---|---|--|
| (1) Coolant Temperature Sensor | (8) High Pressure Engine Oil Temperature Sensor | (13) High Pressure Engine Oil Temperature Sensor |
| (2) Injection Actuation Pressure Control Valve(IAPCV) | (9) Primary Engine Speed/Timing Sensor | (14) Engine Oil Pressure Sensor |
| (3) Inlet Air Heater Relay | (10) Secondary Engine Speed/Timing Sensor | (15) ECM connector J2/P2 |
| (4) Turbocharger Outlet Pressure Sensor | (11) Injection Actuation Pressure Sensor | (16) ECM connector J1/P1 |
| (5) Inlet Air Temperature Sensor | (12) Fuel Pressure Sensor | (17) Oil Grade Detection Plug |
| (6) Timing Calibration Probe | | (18) Atmospheric Pressure Sensor |
| (7) Engine Service Connector J63 | | |

Failure of Sensors

All Sensors

A failure of any of the sensors may be caused by one of the following malfunctions:

- Sensor output is open.
- Sensor output is shorted to “- battery” or “+ battery”.
- Measured reading of the sensor is out of specification.

Programmable Monitoring System (PMS)

The Programmable Monitoring System determines the level of action that is taken by the ECM in response to a condition that can damage the engine. These conditions are identified by the ECM from the signals that are produced from the following sensors.

- Inlet Air Temperature Sensor
- Engine Coolant Temperature Sensor
- Engine Oil Pressure Sensor
- Engine Speed/Timing Sensors
- Fuel Pressure Sensor
- Coolant Level Sensor
- Atmospheric Pressure Sensor

Atmospheric Pressure Sensor

Atmospheric pressure sensor (18) measures barometric pressure. A signal is sent to the Electronic Control Module (ECM).

Table 3

Atmospheric Pressure Sensor	
Operating pressure range	0 to 116 kPa (0 to 16.8 psi)

Turbocharger Outlet Pressure Sensor

Turbocharger outlet pressure sensor (4) provides a signal which corresponds to turbocharger outlet pressure to the ECM. The air/fuel ratio control utilizes the actual engine speed and the turbocharger outlet pressure in order to control the transient smoke level. The ECM can control injection timing and the amount of fuel that is injected. When the throttle is increased and when the engine demands more fuel, the fuel limit is controlled in order to reduce overall smoke levels of the engine exhaust.

Failure of the Turbocharger Outlet Pressure Sensor

The ECM will detect failure of the turbocharger outlet pressure sensor. The operator will be warned of the problem through the diagnostic lamp. The strategies that are related to the boost will be disabled. Engine power will be severely reduced in the event of a failure of the turbocharger outlet pressure sensor. A failure of the turbocharger outlet pressure sensor will not cause a shutdown of the engine.

Coolant Temperature Sensor

Coolant temperature sensor (1) monitors engine coolant temperature. The output of the ECM can indicate a high coolant temperature through a relay or a lamp. The coolant temperature sensor is used by the ECM to determine initiation of the Cold Start Condition.

Table 4

Coolant Temperature Sensor	
Activation temperature for the high coolant temperature fault	103°C (217°F)
Activation temperature for the very high coolant temperature fault	106°C (229°F)

Failure of the Coolant Temperature Sensor

The ECM will detect a failure of the coolant temperature sensor. The diagnostic lamp will warn the operator about the status of the coolant temperature sensor. A failure of the coolant temperature sensor will not cause a shutdown of the engine or any horsepower change.

Engine Oil Pressure Sensor

Engine oil pressure sensor (14) is an absolute pressure sensor that measures the engine oil pressure in the main oil gallery. The engine oil pressure sensor detects engine oil pressure for diagnostic purposes. The engine oil pressure sensor sends a signal to the ECM.

Table 5

Engine Oil Pressure Sensor	
Operating pressure range	0 to 690 kPa (0 to 100 psi)

Low Oil Pressure Warning

The setpoint is dependent upon the engine speed. The fault will be active and logged only if the engine has been running for more than 15 seconds.

Very Low Oil Pressure Warning

The very low oil pressure setpoint is dependent upon the engine speed. If the DERATE mode of the engine monitoring system is selected, the ECM will derate the engine power. The engine horsepower will be limited.

Failure of the Engine Oil Pressure Sensor

The ECM will detect failure of the engine oil pressure sensor. The diagnostic lamp warns the user about the status of the engine oil pressure sensor. The engine oil pressure related strategies will be disabled in the event of a failure of the engine oil pressure sensor. A failure of the engine oil pressure sensor will not cause a shutdown of the engine or any horsepower change.

Engine Oil Temperature Sensor

Engine oil temperature sensor (8) monitors the temperature of the engine oil. The ECM uses the information from the engine oil temperature sensor in order to adjust the timing of the fuel injection and the pressure of the fuel injection.

Table 6

Engine Oil Temperature Sensor	
Operating temperature range	-40 to 120°C (-40 to 258°F)

Crankshaft Position Sensor and Camshaft Position Sensor

If the ECM does not receive a signal from crankshaft position sensor (10), the "DIAGNOSTIC" lamp will indicate a diagnostic fault code which will be logged in the ECM memory.

If the ECM does not receive a signal from the primary speed/timing sensor, the ECM will read the signal from the secondary speed/timing sensor. The ECM continually checks in order to determine if there is a signal from both sensors. If either sensor fails, the faulty sensor should be replaced.

Intermittent failure of the sensors will cause erratic engine control.

Injection Actuation Pressure Sensor

Injection actuation pressure sensor (2) provides a signal of the injection actuation pressure to the ECM. The ECM modifies the current to the injection actuation pressure control valve (not shown) in order to control the injection actuation pressure. The desired actuation pressure is based on the following engine parameters: quantity of fuel, injection timing, engine speed, and engine operating mode.

Inlet Air Temperature Sensor

Inlet air temperature sensor (5) measures the inlet air temperature. A signal is sent to the Electronic Control Module (ECM). The inlet air temperature sensor is also used by the ECM to determine initiation of the Cold Start Strategy.

Table 7

Inlet Air Temperature Sensor	
Operating temperature range	-40 to 120°C (-40 to 258°F)

Throttle Position Sensor

The Throttle Position Sensor (TPS) sends a signal to the ECM. The signal from the TPS is required in order to govern engine speed. The throttle position sensor signal is used by the ECM in order to calculate the desired engine speed. The TPS is calibrated during the initial installation of the engine.

Note: The throttle position sensor is not shown in the illustration.

Failure of the Throttle Position Sensor

An intermittent failure in the TPS causes the engine speed to vary erratically. The ECM will perform the following process:

- The ECM will detect the failure of the TPS.
- The ECM will warn the operator of the failure through the diagnostic lamp.
- The ECM will set the desired engine speed to low idle.

Engine Diagnostics

i01463253

Diagnostic Lamp

SMCS Code: 1000; 1900; 1901; 1902; 7451

The “DIAGNOSTIC” lamp is used to indicate the existence of an active fault by flashing codes.

When the ignition switch is first turned on, the “DIAGNOSTIC” lamp will go through the following procedure:

- The “DIAGNOSTIC” lamp will come on and the “DIAGNOSTIC” lamp will remain on for five seconds. This checks the operation of the lamp.
- The “DIAGNOSTIC” lamp will turn off.
- The “DIAGNOSTIC” lamp will come on again and the “DIAGNOSTIC” lamp will flash codes for any active diagnostic codes. Not all diagnostic codes have a unique flash code.
- The “DIAGNOSTIC” lamp will turn off for five seconds.
- The “DIAGNOSTIC” lamp repeats all active diagnostic codes.

A fault diagnostic code will remain active until the problem is repaired. The electronic control module will continue flashing the flash code at five second intervals until the problem is repaired.

i01474158

Diagnostic Flash Code Retrieval

SMCS Code: 1000; 1900; 1901; 1902

“Diagnostic” Lamp

Use the “DIAGNOSTIC” Lamp or Caterpillar ET in order to determine the diagnostic flash code.

Use the following procedure to retrieve the diagnostic codes if the engine is equipped with a “DIAGNOSTIC” lamp:

1. Turn the ignition key to the ON position. The engine does not need to be started in order to view codes. The engine does not need to be running while the ignition switch is in the ON position.

The “DIAGNOSTIC” lamp blinks on and off at five second intervals.

- When the ignition key is in the ON position, the lamp is checked for proper operation. If there are any active codes except for Code 34, the codes are displayed at this time.

Note: The “DIAGNOSTIC” lamp will illuminate for five seconds. The lamp will stay on if there is an active diagnostic code.

2. The Active Diagnostic codes will always be flashed. There is no toggle switch that will shut off the lamp.
3. The “DIAGNOSTIC” lamp will flash in order to indicate a two-digit code. The sequence of flashes represents the system diagnostic message. Each digit of the two-digit code is determined by counting the number of flashes. The lamp flashes at a rate of two times per second. The lamp will pause for one second between digits. The lamp will pause for two seconds between codes.

Table 8 indicates the potential effect on the engine performance with active flash codes. Table 8 also forms a list of Electronic diagnostic codes and descriptions.

Table 8

Diagnostic Flash Codes for C-9 Industrial Engine							
Diagnostic Flash Code		Effect On Engine Performance			Suggested Action by the Operator		
		Engine Misfire	Low Power	Reduced Engine Speed	Engine Shut Down	Shut down the Engine ⁽¹⁾	Service ⁽²⁾
13	Fault for the Fuel Temperature Sensor ⁽⁴⁾						X
15	Open or Short Circuit of Injection Actuation Pressure Sensor		X			X	
17	High Injection Actuation Pressure					X	X
18	Open or Short for the Injection Actuation Pressure Control Valve				X		X
21	Sensor Supply Voltage Above Normal or Below Normal ⁽⁴⁾		X				X
24	Oil Pressure Sensor Fault ⁽⁴⁾						X
25	Inlet Manifold Air Pressure Sensor Fault ⁽⁵⁾						X
26	Atmospheric Pressure Sensor Fault ⁽⁴⁾		X				X
27	Coolant Temperature Sensor Fault ⁽⁴⁾		X	X			X
28	Check the Adjustments for the Throttle Position Sensor.		X	X			X
34	Loss Of Engine RPM Signal			X	X		X
35	Event for Engine Overspeed				X		X
37	Fuel Pressure Sensor Fault ⁽⁴⁾						X
38	Inlet Manifold Air Temperature Sensor Fault ⁽⁴⁾		X	X			X
39	Mechanical Failure of the Injection Actuation Pressure Sensor		X			X	
42	Check the Calibration of the Timing Sensor.	X	X	X		X	X
46	Low Oil Pressure Event				X	X	X
51	Intermittent Battery Power to the ECM	X	X		X	X	X
52	Personality Module Fault	X	X	X	X		X
56	The following parameters must be checked: Customer and System		X	X			X
59	Incorrect Engine Software	X	X	X			X
61	Event for High Coolant Temperature		X		X	X	X
62	Event for Low Coolant Level		X		X	X	X
63	Low Fuel Pressure Event		X	X		X	X

(continued)

(Table 8, contd)

Diagnostic Flash Codes for C-9 Industrial Engine								
Diagnostic Flash Code		Effect On Engine Performance				Suggested Action by the Operator		
		Engine Misfire	Low Power	Reduced Engine Speed	Engine Shut Down	Shut down the Engine ⁽¹⁾	Service ⁽²⁾	Schedule Service for the Engine. ⁽³⁾
64	Even for High Inlet Manifold Air Temperature		X		X			X
65	Event for High Fuel Temperature		X		X			X
72	Fault of Cylinder 1 or Cylinder 2	X	X				X	
73	Fault of Cylinder 3 or Cylinder 4	X	X				X	
74	Fault of Cylinder 5 or Cylinder 6	X	X				X	

(1) Shut down the Engine: Operate the engine cautiously. Get immediate service. Severe engine damage may result.

(2) The operator should go to the nearest location for service.

(3) The operator should investigate the problem at a convenient time.

(4) The Diagnostic Flash Codes reduce the effectiveness of the Engine Monitoring feature.

(5) These Diagnostic Flash Codes may affect the system only under specific environmental conditions such as engine start-up at cold temperatures, etc.

i01463504

Fault Logging

SMCS Code: 1000; 1900; 1901; 1902

The system provides the capability of Fault Logging. When the Electronic Control Module (ECM) generates an active diagnostic code, the code will be logged in the memory of the ECM. The codes that have been logged in the memory of the ECM can be retrieved with Caterpillar electronic service tools. The codes that have been logged can be cleared with Caterpillar electronic service tools. The codes that have been logged in the memory of the ECM will be automatically cleared from the memory after 100 hours. The following faults can not be cleared from the memory of the ECM without using a factory password: overspeed, low engine oil pressure, and high engine coolant temperature.

i01563981

i01456915

Engine Operation with Active Diagnostic Codes

SMCS Code: 1000; 1900; 1901; 1902

If the diagnostic lamp starts to flash codes during normal engine operation, the system has identified a situation that is not within the specification. Use Caterpillar electronic service tools to check the active diagnostic codes.

Note: If the customer has selected “DERATE” and if there is a low oil pressure condition, the Electronic Control Module (ECM) will limit the engine power until the problem is corrected. If the oil pressure is within the normal range, the engine may be operated at the rated speed and load. However, maintenance should be performed as soon as possible. Refer to Operation and Maintenance Manual, “Diagnostic Flash Code Retrieval” for more information on flash codes.

The active diagnostic code should be investigated. The cause of the problem should be corrected as soon as possible. If the cause of the active diagnostic code is repaired and there is only one active diagnostic code, the diagnostic lamp will turn off.

Operation of the engine and performance of the engine can be limited as a result of the active diagnostic code that is generated. Acceleration rates may be significantly slower. Refer to the Operation and Maintenance Manual for more information on the relationship between these active diagnostic codes and engine performance.

Engine Operation with Intermittent Diagnostic Codes

SMCS Code: 1000; 1900; 1901; 1902

If the diagnostic lamp starts to flash codes during normal engine operation and the diagnostic lamp shuts off, an intermittent fault may have occurred. If a fault has occurred, the fault will be logged into the memory of the Electronic Control Module (ECM).

In most cases, it is not necessary to stop the engine because of an intermittent code. However, the operator should retrieve the logged fault codes and the operator should reference the appropriate information in order to identify the nature of the event. The operator should log any observation that could have caused the lamp to light.

- Low power
- Limits of the engine speed
- Excessive smoke, etc

This information can be useful to help troubleshoot the situation. The information can also be used for future reference. For more information on diagnostic codes, refer to the Troubleshooting Guide for this engine.

Customer Specified Parameters

SMCS Code: 1000; 1900; 1901; 1902

Customer specified parameters that will enhance the fuel efficiency and the operator's convenience can be programmed into the Electronic Control Module (ECM). Some parameters may affect engine operation. This may lead to complaints from the operator about power or about performance.

The following engine related parameters may be programmed by the customer by using Caterpillar electronic service tools in order to influence the operation of the engine:

- Customer Passwords
- Power Rating (hp at rpm)
- Rating Selection (A-E)
- Air/Fuel Ratio
- PTO Ramp Rate
- Engine Parameters: Low Idle, High Idle, Top Engine Limit, Torque Limit, and Intermediate Speed
- Engine Monitoring Mode
- Equipment ID
- Maintenance Indicator
- Auxiliary Pressure
- Auxiliary Temperature
- Parameter Lock Out

The customer specified parameters can be changed as often as needed. Password protection is provided so that the customer can change the parameters. The customer can authorize someone else to change the parameters. Ensure that a record of the parameters is kept in the Operation and Maintenance Manual. For detailed instructions on programming the engine for optimum performance and for optimum fuel economy, consult your Caterpillar dealer.

Engine Starting

i01486758

Before Starting Engine

SMCS Code: 1000; 1400; 1450

Perform the required daily maintenance and other periodic maintenance before the engine is started. Inspect the engine compartment. This inspection can help prevent major repairs at a later date. Refer to the Operation and Maintenance Manual, "Maintenance Interval Schedule" for more information.

- For the maximum service life of the engine, make a thorough inspection before the engine is started. Look for the following items: oil leaks, coolant leaks, loose bolts, and trash buildup. Remove trash buildup and arrange for repairs, as needed.
- Inspect the cooling system hoses for cracks and for loose clamps.
- Inspect the alternator and accessory drive belts for cracks, breaks, and other damage.
- Inspect the wiring for loose connections and for worn wires or frayed wires.
- Check the fuel supply. Drain water from the water separator (if equipped). Open the fuel supply valve.

NOTICE

All valves in the fuel return line must be open before and during engine operation to help prevent high fuel pressure. High fuel pressure may cause filter housing failure or other damage.

If the engine has not been started for several weeks, fuel may have drained from the fuel system. Air may have entered the filter housing. Also, when fuel filters have been changed, some air pockets will be trapped in the engine. In these instances, prime the fuel system. Refer to the Operation and Maintenance Manual, "Fuel System - Prime" for more information on priming the fuel system.

WARNING

Engine exhaust contains products of combustion which may be harmful to your health. Always start and operate the engine in a well ventilated area and, if in an enclosed area, vent the exhaust to the outside.

- Do not start the engine or move any of the controls if there is a "DO NOT OPERATE" warning tag or similar warning tag attached to the start switch or to the controls.
- Ensure that the areas around the rotating parts are clear.
- All of the guards must be put in place. Check for damaged guards or for missing guards. Repair any damaged guards. Replace damaged guards and/or missing guards.
- Disconnect any battery chargers that are not protected against the high current drain that is created when the electric starting motor (if equipped) is engaged. Check electrical cables and check the battery for poor connections and for corrosion.
- Reset all of the shutoffs or alarm components.
- Check the engine lubrication oil level. Maintain the oil level between the "ADD" mark and the "FULL" mark on the oil level gauge.
- Check the coolant level. Observe the coolant level in the coolant recovery tank (if equipped). Maintain the coolant level to the "FULL" mark on the coolant recovery tank.
- If the engine is not equipped with a coolant recovery tank maintain the coolant level within 13 mm (0.5 inch) of the bottom of the filler pipe. If the engine is equipped with a sight glass, maintain the coolant level in the sight glass.
- Observe the air cleaner service indicator (if equipped). Service the air cleaner when the yellow diaphragm enters the red zone, or when the red piston locks in the visible position.
- Ensure that any driven equipment has been disengaged. Minimize electrical loads or remove any electrical loads.

i01512354

Starting the Engine

SMCS Code: 1000; 1450

WARNING

Engine exhaust contains products of combustion which may be harmful to your health. Always start and operate the engine in a well ventilated area and, if in an enclosed area, vent the exhaust to the outside.

Initial Inspection

Perform the required daily maintenance and other periodic maintenance before you start the engine. Inspect the engine compartment. This inspection can help prevent major repairs at a later date. Refer to the Operation and Maintenance Manual, “Walk-Around Inspection” topic (Maintenance Section) for more information.

- For the maximum service life of the engine, make a thorough inspection before you start the engine. Look for the following items: oil leaks, coolant leaks, loose bolts, and trash buildup. Remove trash buildup and arrange for repairs, as needed.
- Inspect the cooling system hoses for cracks and for loose clamps.
- Inspect the alternator and accessory drive belts for cracks, breaks, and other damage.
- Inspect the wiring for loose connections and for worn wires or frayed wires.
- Check the fuel supply. Drain water from the water separator (if equipped). Open the fuel supply valve.

NOTICE

All valves in the fuel return line must be open before and during engine operation to help prevent high fuel pressure. High fuel pressure may cause filter housing failure or other damage.

- Do not start the engine or do not move any of the controls if there is a “DO NOT OPERATE” warning tag or similar warning tag attached to the start switch or to the controls.
- Ensure that the areas around the rotating parts are clear.

- All of the guards must be put in place. Check for damaged guards or for missing guards. Repair any damaged guards. Replace damaged guards and/or missing guards.
- Disconnect any battery chargers that are not protected against the high current drain that is created when the electric starting motor (if equipped) is engaged. Check electrical cables and check the battery for poor connections and for corrosion.
- Reset all of the shutoffs or alarm components.
- Check the engine lubrication oil level. Maintain the oil level between the “ADD” mark and the “FULL” mark on the oil level gauge.
- Check the coolant level. Observe the coolant level in the coolant recovery tank (if equipped). Maintain the coolant level to the “FULL” mark on the coolant recovery tank.
- If the engine is not equipped with a coolant recovery tank maintain the coolant level within 13 mm (.5 inch) of the bottom of the filler pipe. If the engine is equipped with a sight glass, maintain the coolant level in the sight glass.
- Observe the air cleaner service indicator (if equipped). Service the air cleaner when the yellow diaphragm enters the red zone, or when the red piston locks in the visible position.
- Ensure that any driven equipment has been disengaged. Remove any electrical loads.

Cold Weather Starting

Starting the engine and operation in cold weather is dependent on the type of fuel that is used, the oil viscosity, and other optional starting aids. For more information, refer to the Operation and Maintenance Manual, “Cold Weather Operation” topic (Operation Section).

Air Inlet Heater

WARNING

DO NOT USE ETHER (starting fluids) unless specifically instructed to do so. If the engine is equipped with an Air Inlet Heater (electrically or fuel ignited manifold heater), DO NOT use ether (starting fluids) at any time. The use could result in engine damage and/or personal injury.

Note: There will be an indicator lamp on the control panel that is marked “AIR INLET HEATER”.

For detailed information on the operation of the Air Inlet Heater, refer to Troubleshooting Manual, "Air Inlet Heater Circuit - Test".

Refer to the Owner's Manual of the OEM for your type of controls. Use the following procedure to start the engine.

1. Place the transmission in NEUTRAL. Disengage the flywheel clutch in order to allow the engine to start faster. This also reduces the draining of the battery.
2. Turn the ignition switch to the ON position.

The "WARNING and DIAGNOSTIC" lamp (if equipped) will flash while the engine is cranking. The lamp should turn off after proper engine oil pressure is achieved. If the lamp fails to flash, notify your authorized Caterpillar dealer. If the lamp continues to flash, the Electronic Control Module (ECM) has detected a problem in the system. For more information, refer to the Operation and Maintenance Manual, "Diagnostic Flash Code Retrieval" (Operation Section).

NOTICE

Do not engage the starting motor when flywheel is turning. Do not start the engine under load.

If the engine fails to start within 30 seconds, release the starter switch or button and wait two minutes to allow the starting motor to cool before attempting to start the engine again.

3. Push the start button or turn the ignition switch to the START position in order to crank the engine.

Do not push down or hold the throttle down while the engine is cranked. The system will automatically provide the correct amount of fuel that is needed to start the engine.

4. If the engine fails to start within 30 seconds, release the start button, or the ignition switch. Wait for two minutes in order to allow the starting motor to cool before attempting to start the engine again.

Note: The "WARNING and DIAGNOSTIC" lamps (if equipped) may come on after the engine is started. If this occurs, the ECM has detected a problem with the system. For more information, refer to the Operation and Maintenance Manual, "Diagnostic Flash Code Retrieval" (Operation Section) .

NOTICE

Oil pressure should rise within 15 seconds after the engine starts. Do not increase engine rpm until the oil pressure gauge indicates normal. If oil pressure is not indicated on the gauge within 15 seconds, DO NOT operate the engine. STOP the engine, investigate and correct the cause.

5. Allow the engine to idle for approximately three minutes. Idle the engine until the water temperature gauge has begun to rise. Check all gauges during the warm-up period.

Note: Oil pressures and fuel pressures should be in the normal range on the instrument panel. Engines that are equipped with "WARNING" lamps do not have an operating range. The "WARNING and DIAGNOSTIC" lamp (if equipped) will flash while the engine is cranking. The lamp should turn off after proper engine oil pressure or fuel pressure is achieved. Do not apply a load to the engine or increase engine rpm until the oil pressure gauge indicates at least normal pressure. Inspect the engine for leaks and/or unusual noises.

After the engine has started, the air inlet heater may continue to operate in a "Continuous" mode and/or in an "Intermittent" mode. The air inlet heater will turn OFF when the sum of the coolant temperature and the air inlet temperature exceeds 35 °C or 127 °F.

If the engine is operated with a low load, the engine will reach normal operating temperature sooner than idling the engine with no load. When the engine is idled in cold weather, increase the engine rpm to approximately 1000 to 1200 rpm. This will warm up the engine more quickly. Do not exceed the recommended rpm in order to increase the speed of the warm-up. Limit unnecessary idle time to ten minutes.

Ether Injection System

WARNING

Personal injury or property damage can result from alcohol or starting fluids.

Alcohol or starting fluids are highly flammable and toxic and if improperly stored could result in injury or property damage.

⚠ WARNING

DO NOT USE ETHER (starting fluids) unless specifically instructed to do so. If the engine is equipped with an Air Inlet Heater (electrically or fuel ignited manifold heater), DO NOT use ether (starting fluids) at any time. The use could result in engine damage and/or personal injury.

NOTICE

The optional automatic ether injection system is the only starting fluid system that is recommended. Excessive starting fluid can cause piston and ring damage. Use starting fluid for cold starting purposes only.

Startability will be improved at temperatures below 0 °C (32 °F) by the use of a continuous flow injection system and/or a jacket water heater. This will help alleviate white smoke and misfire during start-up in cold weather. Consult your Caterpillar dealer for other means of improving startability in cold temperatures.

The Continuous Flow Ether is an optional ether starting aid that is available for use with the engine. The system injects ether into the air inlet manifold after the air inlet heater. Extensive damage to the engine could occur if ether is directed at the air inlet heater during activation.

Continuous Flow Ether Control has two modes, the Manual Mode and the Automatic Mode.

Manual Mode:

In the manual mode, as the ether switch is depressed there is a predetermined amount of ether that is injected. The manual mode is disabled, if the engine speed is more than 200 rpm above the low idle, if the ambient air temperature is above 0° C (32° F), or if the coolant temperature is above 0° C 32° F.

If the engine is equipped with the ether injection system, perform the following procedure for the manual mode:

1. Crank the engine.
2. Depress the ether switch.
3. Hold the ether switch for three seconds.
4. Release the ether switch.

Automatic Mode:

When the ether switch is placed in the automatic mode, the ether injection system operates automatically, when the engine is cranking. The automatic mode is enabled if the engine has been idling for less than 10 seconds, if the engine speed is less than 200 rpm above low idle, if the ambient air temperature is below 0° C (32° F), and if the coolant temperature is below 0° (32° F).

Additional injections may be necessary in order to start the engine. Additional injections may be necessary in order to achieve the low idle speed. For additional information on the Ether Injection System refer to Troubleshooting Manual, "Air Inlet Heater Circuit - Test".

Starting Problems

An occasional starting problem may be caused by one of the following items:

- Low battery charge
- Lack of fuel
- Problem with the wiring harness

If the engine fuel system has been run dry, fill the fuel tank and prime the fuel system. Refer to the Operation and Maintenance Manual, "Fuel System - Prime" topic (Maintenance Section).

If the other problems are suspected, perform the appropriate procedure in order to start the engine.

Problems with the Wiring Harness

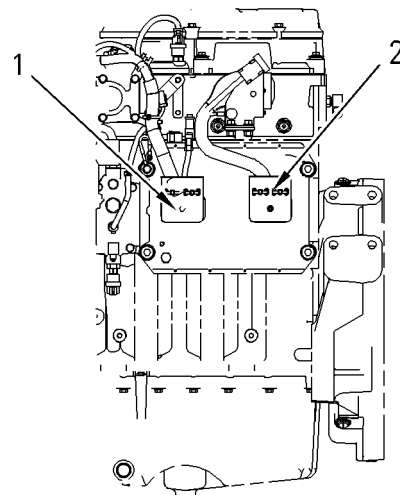

Illustration 27

g00772964

- (1) ECM Connector J2/P2
- (2) ECM Connector J1/P1

Locate the ECM. Two harness connectors are attached to the ECM. One connector is ECM J2/P2 (1) and the other connector is ECM J1/P1. Check the connectors in order to ensure that the connectors are secure. Lightly pull each of the wires in the chassis harness.

1. Pull each wire with approximately 4.5 kg (10 lb) of force. The wire should remain in the connector.
2. If a wire is loose, push the wire back into the connector. Pull the wire again in order to ensure that the wire is secure.
3. Start the engine. If the engine does not start, consult the nearest Caterpillar dealer for assistance.

i01037941

Starting with Jump Start Cables

SMCS Code: 1000; 1401; 1402; 1900

WARNING

Improper jump start cable connections can cause an explosion resulting in personal injury.

Prevent sparks near the batteries. Sparks could cause vapors to explode. Do not allow jump start cable ends to contact each other or the engine.

If the installation is not equipped with a backup battery system, it may be necessary to start the engine from an external electrical source.

First, determine the reason that it is necessary to start with power from an external source. Refer to Special Instruction, SEHS7768, "Use of the 6V-2150 Starting/Charging Analyzer".

Many batteries which are considered unusable are still rechargeable. After jump starting, the alternator may not be able to fully recharge batteries that are severely discharged. The batteries must be charged to the proper voltage with a battery charger. For information on testing and charging, refer to the Special Instruction, SEHS7633, "Battery Test Procedure".

NOTICE

Using a battery source with the same voltage as the electric starting motor. Use **ONLY** equal voltage for jump starting. The use of higher voltage will damage the electrical system.

Do not reverse the battery cables. The alternator can be damaged. Attach ground cable last and remove first.

When using an external electrical source to start the engine, turn the engine control switch to the "OFF" position. Turn all electrical accessories OFF before attaching the jump start cables.

Ensure that the main power switch is in the OFF position before attaching the jump start cables to the engine being started.

1. Turn the start switch on the stalled engine to the OFF position. Turn off all accessories.
2. Connect one positive end of the jump start cable to the positive cable terminal of the discharged battery. Connect the other positive end of the jump start cable to the positive cable terminal of the electrical source.
3. Connect one negative end of the jump start cable to the negative cable terminal of the electrical source. Connect the other negative end of the jump start cable to the engine block or to the chassis ground. This procedure helps to prevent potential sparks from igniting combustible gases that are produced by some batteries.
4. Charge the batteries. The engine will not continue to run after starting if the batteries have not been charged.
5. Start the engine.
6. Immediately after the stalled engine is started, disconnect the jump start cables in reverse order.

Refer to the Electrical Schematic for your engine. Consult your Caterpillar dealer for more information.

After Starting Engine

SMCS Code: 1000

Note: In temperatures from 0 to 60°C (32 to 140°F), the warm-up time is approximately three minutes. In temperatures below 0°C (32°F), additional warm-up time may be required.

Note: Ensure that the self test for the monitoring system (if equipped) is completed before operating the engine under load.

When the engine idles during warm-up, observe the following conditions:

- Check for any fluid or for any air leaks at idle rpm and at one-half full rpm (no load on the engine) before operating the engine under load. This is not possible in some applications.
- Operate the engine at low idle until all systems achieve operating temperatures. Check all gauges during the warm-up period.

Note: Gauge readings should be observed and the data should be recorded frequently while the engine is operating. Comparing the data over time will help to determine normal readings for each gauge. Comparing data over time will also help detect abnormal operating developments. Significant changes in the readings should be investigated.

Engine Operation

i00718869

Engine Operation

SMCS Code: 1000

Proper operation and maintenance are key factors in obtaining the maximum life and economy of the engine. If the directions in the Operation and Maintenance Manual are followed, costs can be minimized and engine service life can be maximized.

The time that is needed for the engine to reach normal operating temperature can be less than the time needed for a walk-around inspection of the engine.

After the engine is started and after the engine reaches normal operating temperature, the engine can be operated at the rated rpm. The engine will reach normal operating temperature faster when the engine is at rated speed. The engine will reach normal operating temperature faster when the engine is at low power demand. This procedure is more effective than idling the engine at no load. The engine should reach operating temperature in a few minutes.

Gauge readings should be observed and the data should be recorded frequently while the engine is operating. Comparing the data over time will help to determine normal readings for each gauge. Comparing data over time will also help detect abnormal operating developments. Significant changes in the readings should be investigated.

Engaging the Driven Equipment

SMCS Code: 1000

1. Operate the engine at one-half of the rated rpm, when possible.
2. Engage the driven equipment without a load on the equipment, when possible.

Interrupted starts put excessive stress on the drive train. Interrupted starts also waste fuel. To get the driven equipment in motion, engage the clutch smoothly with no load on the equipment. This method should produce a start that is smooth and easy. The engine rpm should not increase and the clutch should not slip.

3. Ensure that the ranges of the gauges are normal when the engine is operating at one-half of the rated rpm. Ensure that all gauges operate properly.
4. Increase the engine rpm to the rated rpm. Always increase the engine rpm to the rated rpm before the load is applied.
5. Apply the load. Begin operating the engine at low load. Check the gauges and equipment for proper operation. After normal oil pressure is reached and the temperature gauge begins to move, the engine may be operated at full load. Check the gauges and equipment frequently when the engine is operated under load.

Extended operation at low idle or at reduced load may cause increased oil consumption and carbon buildup in the cylinders. This carbon buildup results in a loss of power and/or poor performance.

Engine Stopping

i01057253

Stopping the Engine

i01428739

SMCS Code: 1000; 7000

NOTICE

Stopping the engine immediately after it has been working under load can result in overheating and accelerated wear of the engine components.

If the engine has been operating at high rpm and/or high loads, run at low idle for at least three minutes to reduce and stabilize internal engine temperature before stopping the engine.

Avoiding hot engine shutdowns will maximize turbocharger shaft and bearing life.

Prior to stopping an engine that is being operated at low loads, operate the engine at low idle for 30 seconds before stopping. If the engine has been operating at highway speeds and/or at high loads, operate the engine at low idle for at least three minutes. This procedure will cause the internal engine temperature to be reduced and stabilized.

Ensure that the engine stopping procedure is understood. Stop the engine according to the shutoff system on the engine or refer to the instructions that are provided by the OEM.

- To stop the engine, turn the ignition key switch to the OFF position.

Emergency Stopping

SMCS Code: 1000; 7418

NOTICE

Emergency shutoff controls are for EMERGENCY use ONLY. DO NOT use emergency shutoff devices or controls for normal stopping procedure.

Ensure that any components for the external system that support the engine operation are secured after the engine is stopped.

Emergency Stop Button

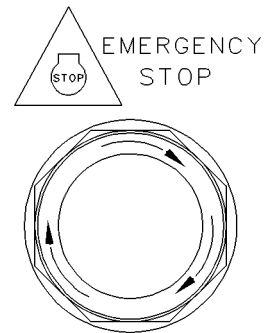

Illustration 28

g00104303

Typical emergency stop button

The emergency stop button is in the OUT position for normal engine operation. Push the emergency stop button. The engine will not start when the button is locked. Turn the button clockwise in order to reset.

i01646416

i01465494

Manual Stop Procedure

SMCS Code: 1000

Note: Individual applications will have different control systems. Ensure that the shutoff procedures are understood. Use the following general guidelines in order to stop the engine.

1. Remove the load, when possible. Reduce the engine speed (rpm) to low idle.
2. Increase the engine speed (rpm) to no more than one-half of the rated rpm. Perform this procedure for three to five minutes in order to cool the engine. Reduce the engine speed (rpm) to low idle.
3. After the cool down period, turn the key switch to the OFF position.

After Stopping Engine

SMCS Code: 1000

Note: Before you check the engine oil, do not operate the engine for at least 10 minutes in order to allow the engine oil to return to the oil pan.

- Check the crankcase oil level. Maintain the oil level between the “ADD” mark and the “FULL” mark on the oil level gauge.
- If necessary, perform minor adjustments. Repair any leaks and tighten any loose bolts.
- Note the service hour meter reading. Perform the maintenance that is in the Operation and Maintenance Manual, “Maintenance Interval Schedule”.
- Fill the fuel tank in order to help prevent accumulation of moisture in the fuel. Do not overfill the fuel tank.

NOTICE

Only use antifreeze/coolant mixtures recommended in the Coolant Specifications that are in the Operation and Maintenance Manual. Failure to do so can cause engine damage.

- Allow the engine to cool. Check the coolant level.
- If freezing temperatures are expected, check the coolant for proper antifreeze protection. The cooling system must be protected against freezing to the lowest expected outside temperature. Add the proper coolant/water mixture, if necessary.
- Perform all required periodic maintenance on all driven equipment. This maintenance is outlined in the instructions from the OEM.

Cold Weather Operation

i01457051

Radiator Restrictions

SMCS Code: 1353; 1396

Caterpillar discourages the use of airflow restriction devices that are mounted in front of radiators. Airflow restriction can cause the following conditions:

- High exhaust temperatures
- Power loss
- Excessive fan usage
- Reduction in fuel economy

If an airflow restriction device must be used, the device should have a permanent opening directly in line with the fan hub. The device must have a minimum opening dimension of at least 770 cm² (120 in²).

A centered opening that is directly in line with the fan hub is specified in order to prevent an interrupted airflow on the fan blades. Interrupted airflow on the fan blades could cause a fan failure.

Caterpillar recommends a warning device for the inlet manifold temperature and/or the installation of an inlet air temperature gauge. The warning device for the inlet manifold temperature should be set at 75 °C (167 °F). The inlet manifold air temperature should not exceed 75 °C (167 °F). Temperatures that exceed this limit can cause power loss and potential engine damage.

i01190421

Fuel and the Effect from Cold Weather

SMCS Code: 1000; 1250

The following fuels are the grades that are available for Caterpillar engines:

- No. 1
- No. 2
- Blend of No. 1 and No. 2

No. 2 diesel fuel is the most commonly used fuel. Either No. 1 diesel fuel or a blend of No. 1 and No. 2 is best suited for cold weather operation.

Quantities of No. 1 diesel fuel are limited. No. 1 diesel fuels are usually available during the months of the winter in the colder climates. During cold weather operation, if No. 1 diesel fuel is not available, use No. 2 diesel fuel, if necessary.

There are three major differences between No. 1 and No. 2 diesel fuel. No. 1 diesel fuel has the following properties:

- Lower cloud point
- Lower pour point
- Lower rating of kJ (BTU) per unit volume of fuel

When No. 1 diesel fuel is used, a decrease in power and in fuel efficiency may be noticed. Other operating effects should not be experienced.

The cloud point is the temperature when a cloud of wax crystals begins to form in the fuel. These crystals can cause the fuel filters to plug. The pour point is the temperature when diesel fuel will thicken. The diesel fuel becomes more resistant to flow through fuel pumps and through fuel lines.

Be aware of these values when diesel fuel is purchased. Anticipate the average ambient temperature within the area that the engine will be operated. Engines that are fueled in one climate may not operate well if the engines are moved to another climate. Problems can result due to changes in temperature.

Before troubleshooting for low power or for poor performance in the winter, check the type of fuel that is being used.

When No. 2 diesel fuel is used the following components provide a means of minimizing problems in cold weather:

- Starting aids
- Engine oil pan heaters
- Engine coolant heaters
- Fuel heaters
- Fuel line insulation

For more information on cold weather operation, see Operation and Maintenance Manual, SEBU5898, "Cold Weather Recommendations".

i01505157

Fuel Related Components in Cold Weather

SMCS Code: 1000; 1250

Fuel Tanks

Condensation can form in partially filled fuel tanks. Top off the fuel tanks after operating the engine.

Fuel tanks should contain some provision for draining water and sediment from the bottom of the tanks. Some fuel tanks use supply pipes that allow water and sediment to settle below the end of the fuel supply pipe.

Some fuel tanks use supply lines that take fuel directly from the bottom of the tank. If the engine is equipped with this system, regular maintenance of the fuel system filter is important.

Drain the water and sediment from any fuel storage tank at the following intervals:

- Weekly
- Oil changes
- Refueling of the fuel tank

This will help prevent water and/or sediment from being pumped from the fuel storage tank and into the engine fuel tank.

Fuel Filters

NOTICE

Do not fill the fuel filters with fuel before installing them. The fuel would not be filtered and could be contaminated. Contaminated fuel will cause accelerated wear to fuel system parts.

NOTICE

In order to maximize fuel system life and prevent premature wear out from abrasive particles in the fuel, a two micron absolute high efficiency fuel filter is required for all Caterpillar Hydraulic Electronic Unit Injectors. Caterpillar High Efficiency Fuel Filters meet these requirements. Consult your Caterpillar dealer for the proper part numbers.

These engines are equipped with a primary filter/water separator. The primary filter/water separator must use a 10 micron filter to a 15 micron filter. The filters are becoming more critical as fuel injection pressures increase to 209 MPa (30000 psi) and higher psi. For more information on priming the fuel system, see the Operation and Maintenance Manual, "Fuel System - Prime" topic (Maintenance Section).

Fuel Heaters

Fuel heaters help to prevent fuel filters from plugging in cold weather due to waxing. A fuel heater should be installed in order for the fuel to be heated before the fuel enters the primary fuel filter.

Select a fuel heater that is mechanically simple, yet adequate for the application. The fuel heater should also help to prevent overheating of the fuel. High fuel temperatures reduce engine performance and the availability of engine power. Choose a fuel heater with a large heating surface. The fuel heater should be practical in size. Small heaters can be too hot due to the limited surface area.

Disconnect the fuel heater in warm weather.

Note: Fuel heaters that are controlled by the water temperature regulator or self-regulating fuel heaters should be used with this engine. Fuel heaters that are not controlled by the water temperature regulator can heat the fuel in excess of 65° C (149° F). A loss of engine power can occur if the fuel supply temperature exceeds 37° C (100° F).

Note: Heat exchanger type fuel heaters should have a bypass provision in order to prevent overheating of the fuel in warm weather operation.

For further information on fuel heaters, consult your Caterpillar dealer.

Maintenance Section

Lubricant Specifications

i01111306

Lubricant Information

SMCS Code: 1000; 1300; 7581

General Information

Because of government regulations regarding the certification of engine exhaust emissions, the lubricant recommendations must be followed.

Engine Manufacturers Association (EMA) Oils

The "Engine Manufacturers Association Recommended Guideline on Diesel Engine Oil" is recognized by Caterpillar. For detailed information about this guideline, see the latest edition of EMA publication, "EMA LRG-1".

API Oils

The Engine Oil Licensing and Certification System by the American Petroleum Institute (API) is recognized by Caterpillar. For detailed information about this system, see the latest edition of the "API publication No. 1509". Engine oils that bear the API symbol are authorized by API.

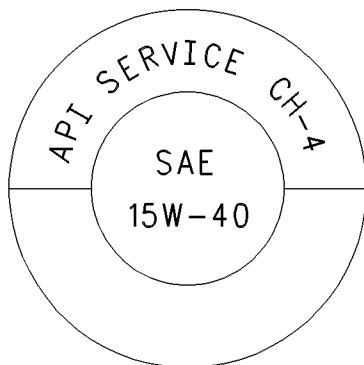

Illustration 29

g00546535

Typical API symbol

Diesel engine oils CC, CD, CD-2, and CE have not been API authorized classifications since 1 January 1996. Table 9 summarizes the status of the classifications.

Table 9

API Classifications	
Current	Obsolete
CF-4, CG-4, CH-4	CE
CF	CC, CD
CF-2 ⁽¹⁾	CD-2 ⁽¹⁾

⁽¹⁾ CD-2 and API CF-2 are classifications for two-cycle diesel engines. Caterpillar does not sell engines that utilize CD-2 and API CF-2 oils.

Note: API CF is not the same classification as API CF-4. API CF oils are only recommended for Caterpillar 3600 Series Diesel Engines and Caterpillar engines with precombustion chamber (PC) fuel systems.

Grease

The classifications of grease are based on the "ASTM D217" worked penetration characteristics. These characteristics for grease are given a defined consistency number.

Terminology

Certain abbreviations follow the nomenclature of "SAE J754". Some classifications follow "SAE J183" abbreviations, and some classifications follow the "EMA Recommended Guideline on Diesel Engine Oil". In addition to Caterpillar definitions, there are other definitions that will be of assistance in purchasing lubricants. Recommended oil viscosities can be found in this publication, "Engine Oil" topic (Maintenance Section).

i01539915

Engine Oil

SMCS Code: 1300; 1348; 7581

Caterpillar Diesel Engine Oil

Caterpillar Oils have been developed and tested in order to provide the full performance and service life that has been designed and built into Caterpillar Engines. Caterpillar Oils are currently used to fill diesel engines at the factory. These oils are offered by Caterpillar dealers for continued use when the engine oil is changed. Consult your Caterpillar dealer for more information on these oils.

Due to significant variations in the quality and in the performance of commercially available oils, Caterpillar makes the following recommendations:

- **Caterpillar Diesel Engine Oil (10W30)**

● **Caterpillar Diesel Engine Oil (15W40)**

Caterpillar multigrade Diesel Engine Oil is formulated with the correct amounts of detergents, dispersants, and alkalinity in order to provide superior performance in Caterpillar Diesel Engines.

Caterpillar multigrade Diesel Engine Oil is available in two viscosity grades (10W30 and 15W40). For direct injection engines, see Table 10 in order to choose the correct viscosity grade for the ambient temperature. Multigrade oils provide the correct viscosity for a broad range of operating temperatures.

Multigrade oils are effective in maintaining low oil consumption and low levels of piston deposits.

Caterpillar multigrade Diesel Engine Oil can be used in other diesel engines and in gasoline engines. See the engine manufacturer's guide for the recommended specifications. Compare the specifications to the specifications of Caterpillar multigrade Diesel Engine Oil. The current industry standards for Caterpillar Diesel Engine Oil are listed on the product label and on the data sheets for the product.

Consult your Caterpillar dealer for part numbers and for available sizes of containers.

Commercial Oils

The performance of commercial diesel engine oils is based on American Petroleum Institute (API) classifications. These API classifications are developed in order to provide commercial lubricants for a broad range of diesel engines that operate at various conditions.

If Caterpillar multigrade Diesel Engine Oil is not used, only use commercial oils that meet the following classifications:

- EMA LRG-1 multigrade oil (preferred oil)
- API CH-4 multigrade oil (preferred oil)
- API CG-4 multigrade oil (preferred oil)
- API CF-4 multigrade oil (acceptable oil)

In order to make the proper choice of a commercial oil, refer to the following explanations:

EMA LRG-1 – The Engine Manufacturers Association (EMA) has developed lubricant recommendations as an alternative to the API oil classification system. LRG-1 is a Recommended Guideline that defines a level of oil performance for these types of diesel engines: high speed, four stroke cycle, heavy-duty, and light duty. LRG-1 oils may be used in Caterpillar engines when the following oils are recommended: API CH-4, API CG-4, and API CF-4. LRG-1 oils are intended to provide superior performance in comparison to API CG-4 and API CF-4.

LRG-1 oils will meet the needs of high performance Caterpillar diesel engines that are operating in many applications. The tests and the test limits that are used to define LRG-1 are similar to the new API CH-4 classification. Therefore, these oils will also meet the requirements of the low emissions diesel engines. LRG-1 oils are designed to control the harmful effects of soot with improved wear resistance and improved resistance to plugging of the oil filter. These oils will also provide superior piston deposit control for engines with either two-piece steel pistons or aluminum pistons.

All LRG-1 oils must complete a full test program with the base stock and with the viscosity grade of the finished commercial oil. The use of "API Base Oil Interchange Guidelines" are not appropriate for LRG-1 oils. This feature reduces the variation in performance that can occur when base stocks are changed in commercial oil formulations.

LRG-1 oils are recommended for use in extended oil change interval programs that optimize oil life. These oil change interval programs are based on oil analysis. LRG-1 oils are recommended for conditions that demand a premium oil. Your Caterpillar dealer has the specific guidelines for optimizing oil change intervals.

API CH-4 – API CH-4 oils were developed in order to meet the requirements of the new high performance diesel engines. Also, the oil was designed to meet the requirements of the low emissions diesel engines. API CH-4 oils are also acceptable for use in older diesel engines and in diesel engines that use high sulfur diesel fuel. API CH-4 oils may be used in Caterpillar engines that use API CG-4 and API CF-4 oils. API CH-4 oils will generally exceed the performance of API CG-4 oils in the following criteria: deposits on pistons, control of oil consumption, wear of piston rings, valve train wear, viscosity control, and corrosion.

Three new engine tests were developed for the API CH-4 oil. The first test specifically evaluates deposits on pistons for engines with the two-piece steel piston. This test (piston deposit) also measures the control of oil consumption. A second test is conducted with moderate oil soot. The second test measures the following criteria: wear of piston rings, wear of cylinder liners, and resistance to corrosion. A third new test measures the following characteristics with high levels of soot in the oil: wear of the valve train, resistance of the oil in plugging the oil filter, and control of sludge.

In addition to the new tests, API CH-4 oils have tougher limits for viscosity control in applications that generate high soot. The oils also have improved oxidation resistance. API CH-4 oils must pass an additional test (piston deposit) for engines that use aluminum pistons (single piece). Oil performance is also established for engines that operate in areas with high sulfur diesel fuel.

All of these improvements allow the API CH-4 oil to achieve optimum oil change intervals. API CH-4 oils are recommended for use in extended oil change intervals. API CH-4 oils are recommended for conditions that demand a premium oil. Your Caterpillar dealer has specific guidelines for optimizing oil change intervals.

API CG-4 – API CG-4 oils were developed primarily for diesel engines that use a 0.05 percent level of fuel sulfur. However, API CG-4 oils can be used with higher sulfur fuels. The TBN of the new oil determines the maximum fuel sulfur level for API CG-4 and API CF-4 oils. See Illustration 30.

API CG-4 oils are the first oils that are required to pass industry standard tests for foam control and viscosity shear loss. API CG-4 oils must also pass tests that were developed for corrosion, wear and oxidation.

API CF-4 – These oils service a wide variety of modern diesel engines. API CF-4 oils provide more stable oil control and reduced piston deposits in comparison to API CF and the obsolete CE and CD classifications of oil. API CF-4 oils provide improved soot dispersancy in comparison to API CF and obsolete CD oils. The API CF-4 classification was developed with a 0.40 percent sulfur diesel fuel. This represents the type of diesel fuels that are commonly available worldwide.

Note: Do not use single grade API CF oils or multigrade API CF oils in Caterpillar Direct Injection (DI) Commercial Diesel Engines.

Some commercial oils that meet the API classifications may require reduced oil change intervals. To determine the oil change interval, closely monitor the condition of the oil and perform a wear metal analysis. Caterpillar's S·O·S oil analysis program is the preferred method.

NOTICE

Failure to follow these oil recommendations can cause shortened engine service life due to deposits and/or excessive wear.

Total Base Number (TBN) and Fuel Sulfur Levels for Direct Injection (DI) Diesel Engines

The Total Base Number (TBN) for an oil depends on the fuel sulfur level. For direct injection engines that use distillate fuel, the minimum TBN of the new oil must be 10 times the fuel sulfur level. The TBN is defined by "ASTM D2896". The minimum TBN of the oil is 5 regardless of fuel sulfur level. Illustration 30 demonstrates the TBN.

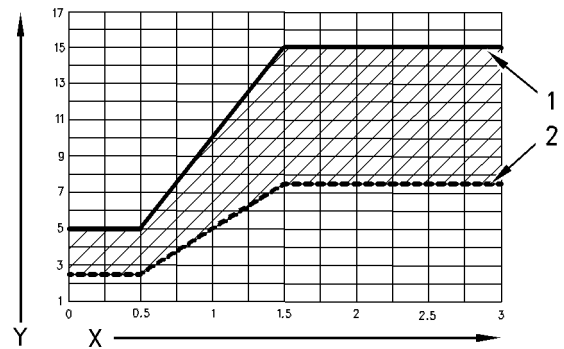

Illustration 30

g00799818

(Y) TBN by "ASTM D2896"

(X) Percentage of fuel sulfur by weight

(1) TBN of new oil

(2) Change the oil when the TBN deteriorates to 50 percent of the original TBN.

Use the following guidelines for fuel sulfur levels that exceed 1.5 percent:

- Choose an oil with the highest TBN that meets one of these classifications: EMA LRG-1, API CH-4, API CG-4, and API CF-4.
- Reduce the oil change interval. Base the oil change interval on the oil analysis. Ensure that the oil analysis includes the condition of the oil and a wear metal analysis.

i01111406

Excessive piston deposits can be produced by an oil with a high TBN. These deposits can lead to a loss of control of the oil consumption and to the polishing of the cylinder bore.

NOTICE

Operating Direct Injection (DI) diesel engines with fuel sulfur levels over 1.0 percent may require shortened oil change intervals in order to help maintain adequate wear protection.

Lubricant Viscosity Recommendations for Direct Injection (DI) Diesel Engines

The proper SAE viscosity grade of oil is determined by the minimum ambient temperature during cold engine start-up, and the maximum ambient temperature during engine operation.

Refer to Table 10 (minimum temperature) in order to determine the required oil viscosity for starting a cold engine.

Refer to Table 10 (maximum temperature) in order to select the oil viscosity for engine operation at the highest ambient temperature that is anticipated.

Generally, use the highest oil viscosity that is available to meet the requirement for the temperature at start-up.

Table 10

Engine Oil Viscosity		
Caterpillar DEO Multigrade EMA LRG-1 API CH-4 API CG-4 and API CF-4 Viscosity Grade	Ambient Temperature	
	Minimum	Maximum
SAE 0W20	-40 °C (-40 °F)	10 °C (50 °F)
SAE 0W30	-40 °C (-40 °F)	30 °C (86 °F)
SAE 0W40	-40 °C (-40 °F)	40 °C (104 °F)
SAE 5W30	-30 °C (-22 °F)	30 °C (86 °F)
SAE 5W40	-30 °C (-22 °F)	40 °C (104 °F)
SAE 10W30	-20 °C (-4 °F)	40 °C (104 °F)
SAE 15W40	-15 °C (5 °F)	50 °C (122 °F)

Synthetic Base Stock Oils

SMCS Code: 1300; 1348; 7581

Synthetic base oils are acceptable for use in Caterpillar engines if these oils meet the performance requirements that are specified for the engine compartment.

Synthetic base oils generally perform better than conventional oils in the following two areas:

- Synthetic base oils have improved flow at low temperatures especially in arctic conditions.
- Synthetic base oils have improved oxidation stability especially at high operating temperatures.

Some synthetic base oils have performance characteristics that enhance the service life of the oil. However, Caterpillar does not recommend the automatic extension of oil change intervals for any type of oil. Oil change intervals for Caterpillar engines can only be adjusted after an oil analysis program that contains the following tests: oil condition and wear metal analysis (Caterpillar's S·O·S oil analysis), trend analysis, fuel consumption, and oil consumption.

i01111412

Re-refined Base Stock Oils

SMCS Code: 1300; 7581

Re-refined base stock oils are acceptable for use in Caterpillar engines if these oils meet the performance requirements that are specified by Caterpillar. Re-refined base stock oils can be used exclusively in finished oil or in a combination with new base stock oils. The US military specifications and the specifications of other heavy equipment manufacturers also allow the use of re-refined base stock oils that meet the same criteria.

The process that is used to make re-refined base stock oil should adequately remove all wear metals that are in the used oil and all additives that are in the used oil. The process that is used to make re-refined base stock oil generally involves the processes of vacuum distillation and hydrotreating the used oil. Filtering is inadequate for the production of high quality re-refined base stock oils from used oil.

Cold Weather Lubricants

SMCS Code: 1300; 1348; 7581

When an engine is started and an engine is operated in ambient temperatures below $-20\text{ }^{\circ}\text{C}$ ($-4\text{ }^{\circ}\text{F}$), use multigrade oils that are capable of flowing in low temperatures.

These oils have lubricant viscosity grades of SAE 0W or SAE 5W.

When an engine is started and operated in ambient temperatures below $-30\text{ }^{\circ}\text{C}$ ($-22\text{ }^{\circ}\text{F}$), use a synthetic base stock multigrade oil with a 0W viscosity grade or with a 5W viscosity grade. Use an oil with a pour point that is lower than $-50\text{ }^{\circ}\text{C}$ ($-58\text{ }^{\circ}\text{F}$).

The number of acceptable lubricants is limited in cold weather conditions. Caterpillar recommends the following lubricants for use in cold weather conditions:

First Choice – use an oil with an EMA LRG-1 Recommended Guideline or use a CH-4 oil that is API licensed with an SAE 0W20, SAE 0W30, SAE 0W40, SAE 5W30, or SAE 5W40 lubricant viscosity grade. A CG-4 oil that is API licensed with an SAE 0W20, SAE 0W30, SAE 0W40, SAE 5W30, or SAE 5W40 lubricant viscosity grade may also be used. A CF-4 oil that is API licensed with an SAE 0W20, SAE 0W30, SAE 0W40, SAE 5W30, or SAE 5W40 lubricant viscosity grade may also be used.

Second Choice – use an oil that contains the CH-4, CG-4, or CF-4 additive package although the oil has not been tested for the requirements of the API license. The oil must have an SAE 0W20, SAE 0W30, SAE 0W40, SAE 5W30, or SAE 5W40 lubricant viscosity grade.

NOTICE

Shortened engine service life could result if second choice oils are used.

Aftermarket Oil Additives

SMCS Code: 1300; 1348; 7581

Caterpillar does not recommend the use of aftermarket additives in oil. It is not necessary to use aftermarket additives in order to achieve the engine's maximum service life or rated performance. Fully formulated, finished oils consist of base oils and of commercial additive packages. These additive packages are blended into the base oils at precise percentages in order to help provide finished oils with performance characteristics that meet industry standards.

There are no industry standard tests that evaluate the performance or the compatibility of aftermarket additives in finished oil. Aftermarket additives may not be compatible with the finished oil's additive package, which could lower the performance of the finished oil. The aftermarket additive could fail to mix with the finished oil. This could produce sludge in the crankcase. Caterpillar discourages the use of aftermarket additives in finished oils.

To achieve the best performance from a Caterpillar engine, conform to the following guidelines:

- Select the proper Caterpillar oil or a commercial oil that meets the "EMA Recommended Guideline on Diesel Engine Oil" or the recommended API classification.
- See the appropriate "Lubricant Viscosities" table in order to find the correct oil viscosity grade for your engine.
- At the specified interval, service the engine compartment. Use new oil and install a new oil filter.
- Perform maintenance at the intervals that are specified in the Operation and Maintenance Manual, "Maintenance Interval Schedule".

Lubricating Grease

SMCS Code: 7581

Caterpillar provides greases in order to cover a variety of applications and extreme temperature conditions. Consult your Caterpillar dealer for part numbers and for available sizes of containers.

Note: Some greases may not be used with other greases. When a commercial grease is used, ensure that the grease is compatible with the grease that is currently used in the system. If the commercial grease is not compatible, the system must be purged. If any questions arise concerning the compatibility of a grease, consult the supplier.

Multipurpose Greases

Multipurpose Lithium Complex Grease (MPGL)

Multipurpose Lithium Complex Grease (MPGL) is a general purpose lithium complex grease for medium-duty applications. This product has good characteristics at high temperatures such as a dropping point of 260 °C (500 °F). MPGL contains unleaded extreme pressure additives, antiwear inhibitors, and corrosion inhibitors that provide extra protection in the following applications:

- Construction
- Agricultural
- Automotive

MPGL meets the requirements for extended service intervals of automotive chassis points. MPGL also meets the requirements for extended service intervals of wheel bearings with disc brakes in automobiles, in vans and in light trucks. This product meets the NLGI certification of “GC-LB”. MPGL is also available in a NLGI No. 2 grade. Normal operating temperatures for this product are –28 to 149 °C (–18 to 300 °F). This product is also available as a white lithium complex grease.

Multipurpose Lithium Complex Grease with Molybdenum (MPGM)

Multipurpose Lithium Complex Grease with Molybdenum (MPGM) is a general purpose lithium complex grease that is used for light-duty applications and for medium-duty applications. The MPGM is available in the following grades: NLGI No. 2 grade and NLGI No. 0 grade. The MPGM is strengthened with a molybdenum disulfide and a polymer for extra lubrication and protection. MPGM contains unleaded additives. MPGM also contains antiwear inhibitors, rust inhibitors, and corrosion inhibitors that are for protection and lubrication in many environments. The MPGM is formulated with a base fluid that has high viscosity.

The MPGM has the following features:

- Increased protection against water washout

- Increased retention
- Resistance to heavy loads

This product is recommended for heavily loaded pin joints and for journal bearings. This product meets the certification of “GC-LB”. Normal operating temperatures for this product are –28 to 149 °C (–18 to 300 °F) for the NLGI No. 0 grade. Normal operating temperatures for this product are –18 to 149 °C (0 to 300 °F) for the NLGI No. 2 grade.

Note: If MPGM is not available, use a multipurpose type grease which contains three to five percent molybdenum.

Special Purpose Grease (SPG)

Bearing Lubricant (SPG)

Bearing Lubricant (SPG) is available in a NLGI No. 2 grade with a polyurea thickener. This grease is recommended for high temperature antifriction bearings in the following applications: electric starting motors, alternators, fan drives, and generators. The Bearing Lubricant (SPG) has an effective operating range of –29 to 177 °C (–20 to 350 °F).

Water and Temperature Resistant Grease (WTR)

The Water and Temperature Resistant Grease is designed for use whenever the following conditions are a concern: water washout, severe corrosion, and high operating temperatures. The Water and Temperature Resistant Grease provides extreme pressure protection, antiwear protection, rust protection and corrosion protection. The Water and Temperature Resistant Grease is an environmentally friendly grease which does not contain the following materials: antimony, sulfur, barium, zinc, lead, and phosphorous materials. The Water and Temperature Resistant Grease has excellent shear stability. Water and Temperature Resistant Grease can also resist breakdown in the presence of water. The Water and Temperature Resistant Grease works well in the following applications:

- Construction
- Agricultural
- Automotive
- Industrial
- Marine

This product meets the NLGI certification of "GC-LB". Normal operating temperatures for this product are -40 to 204°C (-40 to 400°F).

Caterpillar Premium Grease (CPG)

Desert Gold (CPG)

Desert Gold is a heavy-duty, premium synthetic grease that is developed for the most extreme operating environments. This grease is formulated with the following characteristics: high viscosity synthetic base fluid, polymers, molybdenum disulfide, high viscosity index, and high dropping point.

Desert Gold will protect equipment against heavy shock loads. Desert Gold protects against corrosion in extreme heat, in moist conditions, or in dusty conditions. This product has excellent characteristics of adhesion and of stability. Desert Gold provides longer protection than other greases. Desert Gold is an environmentally friendly grease which does not contain the following materials: antimony, sulfur, barium, zinc, lead, and phosphorous materials. Normal operating temperatures are -6 to 230 °C (21 to 450 °F). Desert Gold can operate at higher temperatures for short time periods. Desert Gold has additional extreme pressure protection for highly loaded pin joints.

Arctic Platinum (CPG)

Arctic Platinum is a super-premium extreme pressure lubricating grease that is developed for lubrication in temperatures that are below zero to moderate operating temperatures. Arctic Platinum is available in grades 000, 00, 0, 1, and 2. These grades ensure pumpability in central lube systems in a variety of ambient temperatures from -60 to 18 °C (-76 to 65 °F). Arctic Platinum has a high dropping point. Arctic Platinum contains a five percent concentrate of molybdenum disulfide for protection against extra heavy loads. Arctic Platinum provides excellent corrosion protection and rust protection. Arctic Platinum is an environmentally friendly grease which does not contain the following materials: antimony, sulfur, barium, zinc, and phosphorous.

Arctic Platinum is designed for long life lubrication of the following components: horizontal pivot bearings, lower link bearings, steering cylinders, kingbolt bearings, upper hitch link bearings, and ejector carrier roller bearings. This grease is extra tacky for retention on excavator carbody bearings. Arctic Platinum has additional extreme pressure protection for highly loaded pin joints.

S·O·S Oil Analysis

SMCS Code: 1348; 7542; 7581

Caterpillar recommends the use of the S·O·S oil analysis program in order to monitor the condition and the maintenance requirements of the equipment. The S·O·S oil analysis program will complement the preventive maintenance program.

The S·O·S oil analysis is a diagnostic tool that is used to determine oil performance and component wear rates. Contamination can be identified and measured through the use of the S·O·S oil analysis. The S·O·S oil analysis includes the following tests:

- The Wear Rate Analysis monitors the wear of the engine's metals. The amount of wear metal and type of wear metal that is in the oil is analyzed. The increase in the rate of engine wear metal in the oil is as important as the quantity of engine wear metal in the oil. For this reason, regular sampling at specified intervals is necessary in order to establish wear rates. Intermittent sampling does not allow wear rate trend lines to be established. Engine wear metals in the oil sample are compared to established Caterpillar norms in order to determine acceptability.
- Tests are conducted in order to detect contamination of the oil by water, glycol or fuel.
- The Oil Condition Analysis determines the loss of the oil's lubricating properties. An infrared analysis is used to compare the properties of new oil to the properties of the used oil sample. This analysis allows technicians to determine the amount of deterioration of the oil during use. This analysis also allows technicians to verify the performance of the oil according to the specification during the entire oil change interval.

The test results of the oil samples will then be used as a basis for determining the oil change interval for the engine. The results of the S·O·S oil analysis may allow the engine to operate longer between oil changes without the risk of engine damage.

Table 11

S·O·S Oil Analysis Interval	
Compartment	Interval
Engine crankcase	Every 250 Service Hours
Engine crankcase	Every 500 Service Hours

Consult your Caterpillar dealer for complete information and assistance about the S·O·S oil analysis program.

Fuel Specifications

i01196007

Fuel Recommendations

SMCS Code: 1250; 1280

Diesel engines have the ability to burn a wide variety of fuels. These fuels are divided into two general groups. The two groups are called the preferred fuels and the permissible fuels.

The preferred fuels provide maximum engine service life and performance. The preferred fuels are distillate fuels. These fuels are commonly called diesel fuel, furnace fuel, gas oil, or kerosene.

The permissible fuels are crude oils or blended fuels. Use of these fuels can result in higher maintenance costs and in reduced engine service life.

Diesel fuels that meet the specifications in Table 12 will help to provide maximum engine service life and performance. In North America, diesel fuel that is identified as No. 1-D or No. 2-D in "ASTM D975" generally meet the specifications. Table 12 is for diesel fuels that are distilled from crude oil. Diesel fuels from other sources could exhibit detrimental properties that are not defined or controlled by this specification.

Table 12

Caterpillar Specifications for Distillate Diesel Fuel		
Specifications	Requirements	ASTM Test
Aromatics	35% maximum	"D1319"
Ash	0.02% maximum (weight)	"D482"
Carbon Residue on 10% Bottoms	0.35% maximum (weight)	"D524"
Cetane Number	40 minimum (DI engines)	"D613"
	35 minimum (PC engines)	
Cloud Point	The cloud point must not exceed the lowest expected ambient temperature.	-
Copper Strip Corrosion	No. 3 maximum	"D130"

(continued)

(Table 12, contd)

Caterpillar Specifications for Distillate Diesel Fuel		
Specifications	Requirements	ASTM Test
Distillation	10% at 282 °C (540 °F) maximum	"D86"
	90% at 360 °C (680 °F) maximum	
Flash Point	legal limit	"D93"
API Gravity	30 minimum	"D287"
	45 maximum	
Pour Point	6 °C (10 °F) minimum below ambient temperature	"D97"
Sulfur ⁽¹⁾	3% maximum	"D3605" or "D1552"
Kinematic Viscosity ⁽²⁾	1.4 cSt minimum and 20.0 cSt maximum at 40 °C (104 °F)	"D445"
Water and Sediment	0.1% maximum	"D1796"
Water	0.1% maximum	"D1744"
Sediment	0.05% maximum (weight)	"D473"
Gums and Resins ⁽³⁾	10 mg per 100 mL maximum	"D381"
Lubricity ⁽⁴⁾	3100 g minimum	"D6078"
	0.45 mm (0.018 inch) maximum at 60 °C (140 °F)	
	0.38 mm (0.015 inch) maximum at 25 °C (77 °F)	

- (1) Caterpillar fuel systems and engine components can operate on high sulfur fuels. Fuel sulfur levels affect exhaust emissions. High sulfur fuels also increase the potential for corrosion of internal components. Fuel sulfur levels above 1.0 percent may significantly shorten the oil change interval. For additional information, see this publication, "Engine Oil" topic (Maintenance Section).
- (2) The values of the fuel viscosity are the values as the fuel is delivered to the fuel injection pumps. If a fuel with a low viscosity is used, cooling of the fuel may be required to maintain a 1.4 cSt viscosity at the fuel injection pump. Fuels with a high viscosity might require fuel heaters in order to bring down the viscosity to a 20 cSt viscosity. For additional information, see Special Publication, SEBD0717, "Diesel Fuel and Your Engine".
- (3) Follow the test conditions and procedures for gasoline (motor).
- (4) The lubricity of a fuel is a concern with low sulfur fuel. To determine the lubricity of the fuel, use either the "ASTM D6078 Scuffing Load Wear Test (SBOCLE)" or the "ASTM D6079 High Frequency Reciprocating Rig (HFRR)" test. If the lubricity of a fuel does not meet the minimum requirements, consult your fuel supplier. Do not treat the fuel without consulting the fuel supplier. Some additives are not compatible. These additives can cause problems in the fuel system.

NOTICE

Operating with fuels that do not meet Caterpillar's recommendations can cause the following effects: starting difficulty, poor combustion, deposits in the fuel injectors, reduced service life of the fuel system, deposits in the combustion chamber, and reduced service life of the engine.

In the USA, 0.05 percent diesel fuels have been used in all on-highway truck engines since 1 January 1994. This low sulfur diesel fuel was mandated as a means of directly reducing particulate emissions from diesel truck engines. This low sulfur fuel will also be used in Caterpillar commercial diesel engines when low emissions are required or when the fuel supply sources provide this type of fuel. Caterpillar has not seen any detrimental effects with 0.05 percent sulfur fuel in Caterpillar diesel engines.

NOTICE

Heavy Fuel Oil (HFO), Residual fuel, or Blended fuel must NOT be used in Caterpillar diesel engines (except in 3600 Series HFO engines). Severe component wear and component failures will result if HFO type fuels are used in engines that are configured to use distillate fuel.

In extreme cold ambient conditions, you may use the distillate fuels that are specified in Table 13. However, the fuel that is selected must meet the requirements that are specified in Table 12. These fuels are intended to be used in operating temperatures that are down to -54 °C (-65 °F).

Table 13

Distillate Fuels ⁽¹⁾	
Specification	Grade
"MIL-T-5624R"	JP-5
"ASTM D1655"	Jet-A-1
"MIL-T-83133D"	JP-8

(1) The fuels that are listed in this Table may not meet the requirements that are specified in the "Caterpillar Specifications for Distillate Diesel Fuel" Table. Consult the supplier for the recommended additives in order to maintain the proper fuel lubricity.

These fuels are lighter than the No. 2 grades of fuel. The cetane number of the fuels in Table 13 must be at least 40. If the viscosity is below 1.4 cSt at 38 °C (100 °F), use the fuel only in temperatures below 0 °C (32 °F). Do not use any fuels with a viscosity of less than 1.2 cSt at 38 °C (100 °F). Fuel cooling may be required in order to maintain the minimum viscosity of 1.4 cSt at the fuel injection pump.

There are many other diesel fuel specifications that are published by governments and by technological societies. Usually, those specifications do not review all the requirements that are addressed in this specification. To ensure optimum engine performance, a complete fuel analysis should be obtained before engine operation. The fuel analysis should include all of the properties that are listed in Table 12.

Cooling System Specifications

i01646523

General Coolant Information

SMCS Code: 1350; 1395

NOTICE

Never add coolant to an overheated engine. Engine damage could result. Allow the engine to cool first.

NOTICE

If the engine is to be stored in, or shipped to an area with below freezing temperatures, the cooling system must be either protected to the lowest outside temperature or drained completely to prevent damage.

NOTICE

Frequently check the specific gravity of the coolant for proper freeze protection or for anti-boil protection.

Clean the cooling system for the following reasons:

- Contamination of the cooling system
- Overheating of the engine
- Foaming of the coolant

Note: Air pockets can form in the cooling system if the cooling system is filled at a rate that is greater than 20 L (5 US gal) per minute.

After you drain the cooling system and after you refill the cooling system, operate the engine. Operate the engine without the filler cap until the coolant reaches normal operating temperature and the coolant level stabilizes. Ensure that the coolant is maintained to the proper level.

NOTICE

Never operate an engine without water temperature regulators in the cooling system. Water temperature regulators help to maintain the engine coolant at the proper operating temperature. Cooling system problems can develop without water temperature regulators.

Refer to Special Instruction, SEBD0518, "Know Your Cooling System" and Special Instruction, SEBD0970, "Coolant and Your Engine" for more detailed information.

Many engine failures are related to the cooling system. The following problems are related to cooling system failures: overheating, leakage of the water pump, plugged radiators or heat exchangers, and pitting of the cylinder liners.

These failures can be avoided with proper cooling system maintenance. Cooling system maintenance is as important as maintenance of the fuel system and the lubrication system. Quality of the coolant is as important as the quality of the fuel and the lubricating oil.

Coolant is normally composed of three elements: water, additives, and glycol.

Water

NOTICE

All Caterpillar diesel engines equipped with air-to-air aftercooling (ATAAC) require a minimum of 30 percent glycol to prevent water pump cavitation.

NOTICE

Never use water alone without Supplemental Coolant Additives (SCA) or without inhibited coolant. Water alone is corrosive at engine operating temperatures. Water alone does not provide adequate protection against boiling or freezing.

Water is used in the cooling system in order to transfer heat.

Distilled water or deionized water is recommended for use in engine cooling systems.

DO NOT use the following types of water in cooling systems: hard water, softened water that has been conditioned with salt, and sea water.

If distilled water or deionized water is not available, use water with the properties that are listed in Table 14.

Table 14

Caterpillar Minimum Acceptable Water Requirements		
Property	Maximum Limit	ASTM Test
Chloride (Cl)	40 mg/L (2.4 grains/US gal)	"D512", "D4327"
Sulfate (SO ₄)	100 mg/L (5.9 grains/US gal)	"D516"
Total Hardness	170 mg/L (10 grains/US gal)	"D1126"
Total Solids	340 mg/L (20 grain/US gal)	"D1888"
Acidity	pH of 5.5 to 9.0	"D1293"

For a water analysis, consult one of the following sources:

- Caterpillar dealer
- Local water utility company
- Agricultural agent
- Independent laboratory

Additives

Additives help to protect the metal surfaces of the cooling system. A lack of coolant additives or insufficient amounts of additives enable the following conditions to occur:

- Corrosion
- Formation of mineral deposits
- Rust
- Scale
- Pitting and erosion from cavitation of the cylinder liner
- Foaming of the coolant

Many additives are depleted during engine operation. These additives must be replaced periodically. This can be done by adding Supplemental Coolant Additives (SCA) to Diesel Engine Antifreeze/Coolant (DEAC) or by adding ELC Extender to Extended Life Coolant (ELC).

Additives must be added at the proper concentration. Overconcentration of additives can cause the inhibitors to drop out-of-solution. The deposits can enable the following problems to occur:

- Formation of gel compounds
- Reduction of heat transfer
- Leakage of the water pump seal
- Plugging of radiators, coolers, and small passages

Glycol

Glycol in the coolant helps to provide protection against the following conditions:

- Boiling
- Freezing

For optimum performance, Caterpillar recommends a 1:1 mixture of a water/glycol solution.

Note: Use a mixture that will provide protection against the lowest ambient temperature.

Note: 100 percent pure glycol will freeze at a temperature of -23 °C (-9 °F).

Most conventional heavy-duty coolant/antifreezes use ethylene glycol. Propylene glycol may also be used. In a 1:1 mixture with water, ethylene and propylene glycol provide similar protection against freezing and boiling. See Tables 15 and 16.

Table 15

Ethylene Glycol		
Concentration	Freeze Protection	Boil Protection
50 Percent	-36 °C (-33 °F)	106 °C (223 °F)
60 Percent	-51 °C (-60 °F)	111 °C (232 °F)

NOTICE

Do not use propylene glycol in concentrations that exceed 50 percent glycol because of propylene glycol's reduced heat transfer capability. Use ethylene glycol in conditions that require additional protection against boiling or freezing.

Table 16

Propylene Glycol		
Concentration	Freeze Protection	Boil Protection
50 Percent	-29 °C (-20 °F)	106 °C (223 °F)

To check the concentration of glycol, use the **1U-7298** Coolant/Battery Tester (Degree Celsius) or use the **1U-7297** Coolant/Battery Tester (Degree Fahrenheit). The testers give readings that are immediate and accurate. The testers can be used with ethylene or propylene glycol.

i01096597

Coolant Recommendations

SMCS Code: 1350; 1395

The following two coolants are used in Caterpillar diesel engines:

Preferred – Caterpillar Extended Life Coolant (ELC) or a commercial extended life coolant that meets the Caterpillar EC-1 specification

Acceptable – A Caterpillar Diesel Engine Antifreeze/Coolant (DEAC) or a commercial heavy-duty coolant/antifreeze that meets “ASTM D4985” or “ASTM D5345” specifications

NOTICE

Do not use a commercial coolant/antifreeze that only meets the ASTM D3306 or D4656 specification. This type of coolant/antifreeze is made for light duty automotive applications.

Caterpillar recommends a 1:1 mixture of water and glycol. This mixture of water and glycol will provide optimum heavy-duty performance as a coolant/antifreeze.

Note: Caterpillar DEAC DOES NOT require a treatment with an SCA at the initial fill. Commercial heavy-duty coolant/antifreeze that meets “ASTM D4985” or “ASTM D5345” specifications MAY require a treatment with an SCA at the initial fill. Read the label or the instructions that are provided by the OEM of the product.

In stationary engine applications and marine engine applications that do not require anti-boil protection or freeze protection, a mixture of SCA and water is acceptable. Caterpillar recommends a six percent to eight percent concentration of SCA in those cooling systems. Distilled water or deionized water is preferred. Water which has the recommended properties may be used.

NOTICE

All Caterpillar diesel engines equipped with air-to-air aftercooling (ATAAC) require a minimum of 30 percent glycol to prevent water pump cavitation.

Table 17

Coolant Service Life	
Coolant Type	Service Life
Caterpillar ELC	6000 Service Hours or Six Years
Caterpillar DEAC	3000 Service Hours or Three Years
Commercial Heavy-Duty Coolant/Antifreeze that meets “ASTM D5345”	3000 Service Hours or Two Years
Commercial Heavy-Duty Coolant/Antifreeze that meets “ASTM D4985”	3000 Service Hours or One Year
Caterpillar SCA and Water	3000 Service Hours or Two Years
Commercial SCA and Water	3000 Service Hours or One Year

i01200209

S·O·S Coolant Analysis

SMCS Code: 1352; 1395; 7542

Testing the engine coolant is important to ensure that the engine is protected from internal cavitation and from corrosion. The analysis also tests the ability of the coolant to protect the engine from boiling and from freezing. The S·O·S Coolant Analysis can be done at your Caterpillar dealer. Caterpillar S·O·S Coolant Analysis is the best way to monitor the condition of your coolant and your cooling system. S·O·S Coolant Analysis is a program that is based on periodic samples.

NOTICE

Do not use the same vacuum sampling pump for extracting oil samples that is used for extracting coolant samples.

A small residue of either type sample may remain in the pump and may cause a false positive analysis for the sample being taken.

Always use a designated pump for oil sampling and a designated pump for coolant sampling.

Failure to do so may cause a false analysis which could lead to customer and dealer concerns.

New Systems, Refilled Systems, and Converted Systems

Perform a coolant analysis (Level 2) at 500 service hours for new systems, for refilled systems, or for converted systems that use ELC or use DEAC. This 500 hour check will also check for any residual cleaner that may have contaminated the system.

Recommended Interval for S-O-S Coolant Sample

Perform a coolant analysis (Level 1) at every 500 service hour interval. Perform a coolant analysis (Level 2) annually.

Note: Check the standard coolant's Supplemental Coolant Additive at every oil change.

S-O-S Coolant Analysis (Level 1)

A coolant analysis (Level 1) is a test of the properties of the coolant.

The following properties of the coolant are tested:

- Glycol Concentration for freeze protection
- Ability to protect from erosion and corrosion
- pH
- Conductivity
- Water hardness
- Visual analysis
- Odor analysis

The results are reported, and appropriate recommendations are made.

S-O-S Coolant Analysis (Level 2)

Level 2 coolant analysis is a comprehensive chemical evaluation of the coolant. This analysis is also a check of the overall condition of the inside of the cooling system.

The S-O-S Coolant Analysis has the following five features:

- Full analysis of Level 1
- Identification of the source of metal corrosion and of contaminants

- Identification of buildup of the impurities that cause corrosion
- Identification of buildup of the impurities that cause scaling
- Determination of possible electrolysis within the engines' cooling system

The results are reported, and appropriate recommendations are made.

For more information on S-O-S Coolant Analysis, consult your Caterpillar dealer.

i01096605

Extended Life Coolant (ELC)

SMCS Code: 1350; 1395

Caterpillar provides Extended Life Coolant (ELC) for use in the following applications:

- Heavy-duty spark ignited gas engines
- Heavy-duty diesel engines
- Automotive applications

The anti-corrosion package for Caterpillar ELC is different from the anti-corrosion package for other coolants. Caterpillar ELC is an ethylene glycol base coolant. However, Caterpillar ELC contains organic corrosion inhibitors and antifoam agents with low amounts of nitrite. Caterpillar ELC has been formulated with the correct amount of these additives in order to provide superior corrosion protection for all metals in engine cooling systems.

ELC extends the service life of the coolant to 6000 service hours or six years. ELC does not require a frequent addition of a Supplemental Coolant Additive (SCA). An Extender is the only additional maintenance that is needed at 3000 service hours or one half of the ELC service life.

ELC is available in a 1:1 premixed cooling solution with distilled water. The Premixed ELC provides freeze protection to -36°C (-33°F). The Premixed ELC is recommended for the initial fill of the cooling system. The Premixed ELC is also recommended for topping off the cooling system.

ELC Concentrate is also available. ELC Concentrate can be used to lower the freezing point to -51°C (-60°F) for arctic conditions.

Containers of several sizes are available. Consult your Caterpillar dealer for the part numbers.

Note: Caterpillar developed the EC-1 specification. The EC-1 specification is an industry standard. The EC-1 specification defines all of the performance requirements that are needed for an engine coolant to be sold as an extended life coolant for Caterpillar engines. ELC can be used in most OEM engines of the following types: diesel, gasoline, and natural gas. ELC meets the performance requirements of “ASTM D4985” and “ASTM D5345” for heavy-duty low silicate antifreeze/coolants. ELC also meets the performance requirements of “ASTM D3306” and “ASTM D4656” for automotive applications.

i01111712

Extended Life Coolant (ELC) Cooling System Maintenance

SMCS Code: 1350; 1352; 1395

Proper additions to the Extended Life Coolant

NOTICE

Use only Caterpillar products or commercial products that have passed Caterpillar’s EC-1 specification for pre-mixed or concentrated coolants.

Use only Caterpillar Extender with Extended Life Coolant.

Mixing Extended Life Coolant with other products reduces the Extended Life Coolant service life. Failure to follow the recommendations can reduce cooling system components life unless appropriate corrective action is performed.

In order to maintain the correct balance between the antifreeze and the additives, you must maintain the recommended concentration of Extended Life Coolant (ELC). Lowering the proportion of antifreeze lowers the proportion of additive. This will lower the ability of the coolant to protect the system from pitting, from cavitation, from erosion, and from deposits.

NOTICE

Do not use a conventional coolant to top-off a cooling system that is filled with Extended Life Coolant (ELC).

Do not use standard supplemental coolant additive (SCA). Only use ELC Extender in cooling systems that are filled with ELC.

Caterpillar ELC Extender

Caterpillar ELC Extender is added to the cooling system halfway through the ELC service life. Treat the cooling system with ELC Extender at 3000 hours or one half of the coolant service life. Use Table 18 in order to determine the proper amount of ELC Extender that is required.

Containers of several sizes are available. Consult your Caterpillar dealer for the part numbers.

Table 18

Caterpillar ELC Extender Additions by Cooling System Capacity	
Cooling System Capacity	Addition of ELC Extender
22 to 30 L (6 to 8 US gal)	0.57 L (20 fl oz)
31 to 38 L (9 to 10 US gal)	0.71 L (24 fl oz)
39 to 49 L (11 to 13 US gal)	0.95 L (32 fl oz)
50 to 64 L (14 to 17 US gal)	1.18 L (40 fl oz)
65 to 83 L (18 to 22 US gal)	1.60 L (54 fl oz)
84 to 114 L (23 to 30 US gal)	2.15 L (72 fl oz)
115 to 163 L (31 to 43 US gal)	3.00 L (100 fl oz)
164 to 242 L (44 to 64 US gal)	4.40 L (148 fl oz)

For cooling system capacities that exceed the capacities that are specified in Table 18, use the equation that is in Table 19 in order to determine the proper amount of ELC Extender that is required.

Table 19

Equation For Adding ELC Extender To ELC
$V \times 0.02 = X$
V is the total volume of the cooling system.
X is the amount of ELC Extender that is required.

Table 20 is an example for using the equation that is in Table 19.

Table 20

Example Of The Equation For Adding ELC Extender To ELC		
Total Volume of the Cooling System (V)	Multiplication Factor	Amount of ELC Extender that is Required (X)
946 L (250 US gal)	× 0.02	19 L (5 US gal)

NOTICE

When using Caterpillar ELC, do not use standard SCA's or SCA filters. To avoid SCA contamination of an ELC system, remove the SCA filter base and plug off or by-pass the coolant lines.

ELC Cooling System Cleaning

Note: If the cooling system is already using ELC, cleaning agents are not required to be used at the specified coolant change interval. Cleaning agents are only required if the system has been contaminated by the addition of some other type of coolant or by cooling system damage.

Clean water is the only cleaning agent that is required when ELC is drained from the cooling system.

ELC can be recycled. The drained coolant mixture can be distilled in order to remove the ethylene glycol and the water. The ethylene glycol and the water can be reused. Consult your Caterpillar dealer for more information.

After the cooling system is drained and after the cooling system is refilled, operate the engine while the cooling system filler cap is removed. Operate the engine until the coolant level reaches the normal operating temperature and until the coolant level stabilizes. As needed, add the coolant mixture in order to fill the system to the proper level.

Changing to Caterpillar ELC

To change from heavy-duty coolant/antifreeze to the Caterpillar ELC, perform the following steps:

NOTICE

Care must be taken to ensure that fluids are contained during performance of inspection, maintenance, testing, adjusting and repair of the product. Be prepared to collect the fluid with suitable containers before opening any compartment or disassembling any component containing fluids.

Refer to Special Publication, NENG2500, "Caterpillar Tools and Shop Products Guide" for tools and supplies suitable to collect and contain fluids on Caterpillar products.

Dispose of all fluids according to local regulations and mandates.

1. Drain the coolant into a suitable container.
2. Dispose of the coolant according to local regulations.

NOTICE

Do not leave an empty SCA filter on an ELC system.

The filter housing may corrode and leak causing an engine failure.

Remove the SCA filter base and plug off or by-pass the coolant lines.

3. Remove the empty SCA filter and remove the filter base. Plug the coolant lines or bypass the coolant lines.
4. Flush the system with clean water in order to remove any debris.
5. Use Caterpillar cleaner to clean the system. Follow the instruction on the label.
6. Drain the cleaner into a suitable container. Flush the cooling system with clean water.
7. Fill the cooling system with clean water and operate the engine until the engine is warmed to 49° to 66°C (120° to 150°F).

NOTICE

Improper or incomplete rinsing of the cooling system can result in damage to copper and other metal components.

To avoid damage to the cooling system, make sure to completely flush the cooling system with clear water. Continue to flush the system until all signs of the cleaning agent are gone.

8. Drain the cooling system into a suitable container and flush the cooling system with clean water.

Note: The cooling system cleaner must be thoroughly flushed from the cooling system. Cooling system cleaner that is left in the system will contaminate the coolant. The cleaner may also corrode the cooling system.

9. Repeat Steps 7 and 8 until the system is completely clean.
10. Fill the cooling system with the Caterpillar premixed ELC.
11. Attach the Special Publication, PEEP5027, "Label" to the cooling system filler for the engine in order to indicate the use of Caterpillar ELC.

ELC Cooling System Contamination

i01111753

NOTICE

Mixing ELC with other products reduces the effectiveness of the ELC and shortens the ELC service life. Use only Caterpillar products or commercial products that have passed the Caterpillar EC-1 specification for premixed or concentrate coolants. Use only Caterpillar ELC Extender with Caterpillar ELC. Failure to follow these recommendations can result in shortened cooling system component life.

ELC cooling systems can withstand contamination to a maximum of ten percent of conventional heavy-duty coolant/antifreeze or SCA. If the contamination exceeds ten percent of the total system capacity, perform ONE of the following procedures:

- Drain the cooling system into a suitable container. Dispose of the coolant according to local regulations. Flush the system with clean water. Fill the system with the Caterpillar ELC.
- Drain a portion of the cooling system into a suitable container according to local regulations. Then, fill the cooling system with premixed ELC. This should lower the contamination to less than 10 percent.
- Maintain the system as a conventional Diesel Engine Antifreeze/Coolant (DEAC). Treat the system with an SCA. Change the coolant at the interval that is recommended for the conventional Diesel Engine Antifreeze/Coolant (DEAC).

Commercial ELC

If Caterpillar ELC is not used, then select a commercial ELC that meets the Caterpillar specification of EC-1 and either the "ASTM D5345" specification or the "ASTM D4985" specification. Do not use an extended life coolant that does not meet the EC-1 specification. Follow the maintenance guide for the coolant from the supplier of the commercial ELC. Follow the Caterpillar guidelines for the quality of water and the specified coolant change interval.

Diesel Engine Antifreeze/Coolant (DEAC)

SMCS Code: 1350; 1395

Caterpillar recommends using Caterpillar Diesel Engine Antifreeze/Coolant (DEAC) for cooling systems that require a heavy-duty coolant/antifreeze. Caterpillar DEAC is an alkaline single-phase ethylene glycol type antifreeze that contains corrosion inhibitors and antifoam agents.

Caterpillar DEAC is formulated with the correct amount of Caterpillar Supplemental Coolant Additive (SCA). Do not use SCA at the initial fill when DEAC is used.

Containers of several sizes are available. Consult your Caterpillar dealer for the part numbers.

If concentrated DEAC is used, Caterpillar recommends mixing the concentrate with distilled water or with deionized water. If distilled water is not available or deionized water is not available, use water which has the required properties. For the water properties, see this publication, "General Coolant Information" topic (Maintenance Section).

i01069295

Supplemental Coolant Additive (SCA)

SMCS Code: 1350; 1352; 1395

The use of SCA helps to prevent the following conditions from occurring:

- Corrosion
- Formation of mineral deposits
- Cavitation erosion of the cylinder liners
- Foaming of the coolant

Caterpillar Diesel Engine Antifreeze/Coolant (DEAC) is formulated with the correct level of Caterpillar SCA. When the cooling system is initially filled with DEAC, adding more SCA is not necessary until the concentration of SCA has been depleted. To ensure that the correct amount of SCA is in the cooling system, the concentration of SCA must be tested on a scheduled basis. Refer to the specific engine's Operation and Maintenance Manual, "Maintenance Interval Schedule".

Containers of SCA are available in several sizes. Consult your Caterpillar dealer for the part numbers.

i01164588

Commercial Heavy-Duty Coolant/Antifreeze and SCA

SMCS Code: 1350; 1395

If Caterpillar DEAC is not used, select a coolant/antifreeze with low silicate content for heavy-duty applications that meets “ASTM D5345” or “ASTM D4985” specifications.

Note: When you are not using Caterpillar DEAC the cooling system must be drained one time during every year. The cooling system must be flushed at this time as well.

When a heavy-duty coolant/antifreeze is used, treat the cooling system with three to six percent Caterpillar SCA by volume. For more information, see this publication, “Conventional Coolant/Antifreeze Cooling System Maintenance” topic (Maintenance Section).

If Caterpillar SCA is not used, select a commercial SCA. The commercial SCA must provide a minimum of 1200 mg/L or 1200 ppm (70 grains/US gal) of nitrites in the final coolant mixture.

Coolant/antifreeze that meets “ASTM D5345” or “ASTM D4985” specifications MAY require treatment with SCA at the initial fill. These coolants WILL require treatment with SCA on a maintenance basis.

When concentrated coolant/antifreeze is mixed, Caterpillar recommends mixing the concentrate with distilled water or with deionized water. If distilled water or deionized water is not available, water which has the required properties may be used. For the water properties, see this publication, “General Coolant Information” topic (Maintenance Section).

i01318169

Water/Supplemental Coolant Additive (SCA)

SMCS Code: 1350; 1352; 1395

NOTICE

All Caterpillar diesel engines equipped with air-to-air aftercooling (ATAAC) require a minimum of 30 percent glycol to prevent water pump cavitation.

NOTICE

Never use water alone without Supplemental Coolant Additives (SCA) or without inhibited coolant. Water alone is corrosive at engine operating temperatures. Water alone does not provide adequate protection against boiling or freezing.

Note: Premix the coolant solution in order to provide protection to the lowest ambient temperature that is expected.

Note: Pure undiluted antifreeze freezes at -23°C (-9°F).

In engine cooling systems that use water alone, Caterpillar recommends the use of SCA. SCA helps to prevent the following conditions from occurring:

- Corrosion
- Formation of mineral deposits
- Cavitation erosion of the cylinder liner
- Foaming of the coolant

If Caterpillar SCA is not used, select a commercial SCA. The commercial SCA must provide a minimum of 2400 mg/L or 2400 ppm (140 grains/US gal) of nitrites in the final coolant mixture.

The quality of the water is a very important factor in this type of cooling system. Distilled water or deionized water is recommended for use in cooling systems. If distilled water or deionized water is not available, use water that meets the minimum requirements that are listed in the table for recommended water properties in this publication, “General Coolant Information” topic (Maintenance Section).

A cooling system that uses a mixture of SCA and water only needs more SCA than a cooling system that uses a mixture of glycol and water. The SCA concentration in a cooling system that uses SCA and water should be six to eight percent by volume. Refer to Table 21 for the amount of SCA that is required for various capacities of the cooling system.

Table 21

Caterpillar SCA Requirements for SCA and Water Cooling Systems		
Cooling System Capacity	Caterpillar SCA at Initial Fill	Caterpillar SCA at 250 Hours
22 to 30 L (6 to 8 US gal)	1.75 L (64 fl oz)	0.44 L (15 fl oz)
31 to 38 L (9 to 10 US gal)	2.30 L (80 fl oz)	0.57 L (20 fl oz)
39 to 49 L (11 to 13 US gal)	3.00 L (100 fl oz)	0.75 L (25 fl oz)
50 to 64 L (14 to 17 US gal)	3.90 L (128 fl oz)	0.95 L (32 fl oz)
65 to 83 L (18 to 22 US gal)	5.00 L (168 fl oz)	1.25 L (42 fl oz)
84 to 110 L (23 to 29 US gal)	6.60 L (224 fl oz)	1.65 L (56 fl oz)
111 to 145 L (30 to 38 US gal)	8.75 L (296 fl oz)	2.19 L (74 fl oz)
146 to 190 L (39 to 50 US gal)	11.50 L (392 fl oz)	2.88 L (98 fl oz)
191 to 250 L (51 to 66 US gal)	15.00 L (512 fl oz)	3.75 L (128 fl oz)

Refer to Table 22 for part numbers and for quantities of SCA.

Table 22

Caterpillar Liquid SCA	
Part Number	Quantity
6V-3542	0.24 L (8 oz)
111-2372	0.36 L (12 oz)
8T-1589	0.47 L (16 oz)
3P-2044	0.94 L (32 oz)
8C-3680	19 L (5 US gal)
5P-2907	208 L (55 US gal)

Maintain the SCA in the same way as you would maintain a cooling system that uses heavy-duty coolant/antifreeze. Adjust the maintenance for the amount of SCA additions. See Table 21 for the amount of SCA that is required.

Cooling Systems with Larger Capacities

Adding the SCA to Water at the Initial Fill

Use the equation that is in Table 23 to determine the amount of Caterpillar SCA that is required at the initial fill. This equation is for a mixture of only SCA and water.

Table 23

Equation For Adding The SCA To Water At The Initial Fill
$V \times 0.07 = X$
V is the total volume of the cooling system.
X is the amount of SCA that is required.

Table 24 is an example for using the equation that is in Table 23.

Table 24

Example Of The Equation For Adding The SCA To Water At The Initial Fill		
Total Volume of the Cooling System (V)	Multiplication Factor	Amount of SCA that is Required (X)
946 L (250 US gal)	× 0.07	66 L (18 US gal)

Adding the SCA to Water for Maintenance

For the recommended service interval, refer to the Operation and Maintenance Manual, "Maintenance Interval Schedule" for your engine.

Use the 8T-5296 Coolant Conditioner Test Kit to test the concentration of SCA. Make the following modifications to Steps 3 and 5 of the 8T-5296 Coolant Conditioner Test Kit instructions:

STEP 3 – Add tap water to the vial up to the "20 ml" mark.

STEP 5 – When the defined procedure is used, a concentration of six to eight percent will yield between 20 drops and 27 drops. If the number of drops is below 20 drops, the concentration of SCA is low. If the number of drops is above 27 drops, the concentration of SCA is high. Make the appropriate adjustments to the concentration of SCA.

Test the concentration of SCA or submit a coolant sample to your Caterpillar dealer. See this publication, "S·O·S Coolant Analysis" topic (Maintenance Section).

Additions of SCA are based on the results of the test or based on the results of the coolant analysis. The size of the cooling system determines the amount of SCA that is required.

Use the equation that is in Table 23 to determine the amount of Caterpillar SCA that is required for maintenance, if necessary:

Table 25

SCA To Water Addition Equation For Maintenance
$V \times 0.023 = X$
V is the total volume of the cooling system.
X is the amount of SCA that is required.

Table 26 is an example for using the equation that is in Table 23.

Table 26

SCA To Water Addition Equation Example For Maintenance		
Total Volume of the Cooling System (V)	Multiplication Factor	Amount of SCA that is Required (X)
946 L (250 US gal)	× 0.023	22 L (6 US gal)

Note: Specific engine applications may require maintenance practices to be periodically evaluated in order to properly maintain the engine's cooling system.

Table 22 lists part numbers and quantities of SCA that is available from your Caterpillar dealer.

i01570193

Conventional Coolant/ Antifreeze Cooling System Maintenance

SMCS Code: 1350; 1352; 1395

NOTICE

Never operate an engine without water temperature regulators in the cooling system. Water temperature regulators help to maintain the engine coolant at the proper operating temperature. Cooling system problems can develop without water temperature regulators.

Check the coolant/antifreeze (glycol concentration) in order to ensure adequate protection against boiling or freezing. Caterpillar recommends the use of a refractometer for checking the glycol concentration. Use the **1U-7298** Coolant/Battery Tester (Degree Celsius) or use the **1U-7297** Coolant/Battery Tester (Degree Fahrenheit). The testers give readings that are immediate and accurate. The testers can be used with ethylene or with propylene glycol.

Caterpillar engine cooling systems should be tested at 250 hour intervals for the concentration of Supplemental Coolant Additive (SCA). SCA test kits are available from your Caterpillar dealer. Test the concentration of SCA or submit a coolant sample to your Caterpillar dealer at 250 hour intervals. Refer to S-O-S Coolant Analysis for more information on this topic.

Additions of SCA are based on the results of the test or based on the results of the coolant analysis. An SCA that is liquid or a maintenance element for an SCA (if equipped) may be needed at 250 hour intervals.

Table 27 lists the amount of Caterpillar SCA that is needed at the initial fill in order to treat coolant/antifreeze. These amounts of SCA are for systems that use heavy-duty coolant/antifreeze.

Table 27 also lists additions of SCA for liquid and for maintenance elements at 250 hours. The additions are required for Caterpillar DEAC and for commercial coolant/antifreezes.

Table 27

Caterpillar SCA Requirements for Heavy-Duty Coolant/Antifreeze			
Cooling System Capacity	Initial Fill⁽¹⁾	250 Service Hour Maintenance⁽²⁾	Spin-on Element at 250 Service Hour Maintenance (If Equipped)⁽³⁾
22 to 30 L (6 to 8 US gal)	0.95 L (32 fl oz)	0.24 L (8 fl oz)	111 - 2370 (1)
31 to 38 L (9 to 10 US gal)	1.18 L (40 fl oz)	0.36 L (12 fl oz)	111 - 2369 (1)
39 to 49 L (11 to 13 US gal)	1.42 L (48 fl oz)	0.36 L (12 fl oz)	111 - 2369 (1)
50 to 64 L (14 to 17 US gal)	1.90 L (64 fl oz)	0.47 L (16 fl oz)	9N-3368 (1)
65 to 83 L (18 to 22 US gal)	2.37 L (80 fl oz)	0.60 L (20 fl oz)	111 - 2371 (1)
84 to 114 L (23 to 30 US gal)	3.32 L (112 fl oz)	0.95 L (32 fl oz)	9N-3718 (1)
115 to 163 L (31 to 43 US gal)	4.75 L (160 fl oz)	1.18 L (40 fl oz)	111 - 2371 (2)
164 to 242 L (44 to 64 US gal)	7.60 L (256 fl oz)	1.90 L (64 fl oz)	9N-3718 (2)

⁽¹⁾ When the coolant system is first filled, the SCA is not required to be used with Caterpillar DEAC.

⁽²⁾ Do not exceed the six percent maximum concentration. Check the concentration of SCA with a SCA test kit.

⁽³⁾ Do not use the maintenance element for the SCA and the liquid for the SCA at the same time.

Note: Specific engine applications may require maintenance practices to be periodically evaluated in order to properly maintain the engine's cooling system.

Refer to Table 28 for part numbers and for quantities of SCA.

Table 28

Caterpillar Liquid SCA	
Part Number	Quantity
6V-3542	0.24 L (8 oz)
111-2372	0.36 L (12 oz)
8T-1589	0.47 L (16 oz)
3P-2044	0.94 L (32 oz)
8C-3680	19 L (5 US gal)
5P-2907	208 L (55 US gal)

Cooling Systems with Larger Capacities

Adding the SCA to Conventional Coolant/Antifreeze at the Initial Fill

Note: Caterpillar DEAC DOES NOT require an addition of SCA when the cooling system is initially filled.

Commercial heavy-duty coolant/antifreeze that meets "ASTM D4985" or "ASTM D5345" specifications MAY require an addition of SCA at the initial fill. Read the label or the instructions that are provided by the OEM of the product.

Use the equation that is in Table 29 to determine the amount of Caterpillar SCA that is required when the cooling system is initially filled with the following fluids:

- "ASTM D4985"
- "ASTM D5345"

Table 29

Equation For Adding The SCA To Conventional Coolant/Antifreeze At The Initial Fill
$V \times 0.045 = X$
V is the total volume of the cooling system.
X is the amount of SCA that is required.

Table 30 is an example for using the equation that is in Table 29.

Table 30

Example Of The Equation For Adding The SCA To Conventional Coolant/Antifreeze At The Initial Fill		
Total Volume of the Cooling System (V)	Multiplication Factor	Amount of SCA that is Required (X)
946 L (250 US gal)	× 0.045	43 L (11 US gal)

Adding the SCA to Conventional Coolant/Antifreeze For Maintenance

Heavy duty coolant/antifreeze of all types REQUIRE periodic additions of an SCA.

Test the coolant/antifreeze periodically for the concentration of SCA. For the interval, see the Operation and Maintenance Manual, "Maintenance Interval Schedule" (Maintenance Section). SCA test kits are available from your Caterpillar dealer. Test the concentration of SCA or submit a coolant sample to your Caterpillar dealer. See this publication, "S·O·S Coolant Analysis" topic (Maintenance Section).

Additions of SCA are based on the results of the test or based on the results of the coolant analysis. The size of the cooling system determines the amount of SCA that is needed.

Use the equation that is in Table 31 to determine the amount of Caterpillar SCA that is required, if necessary:

Table 31

Equation For Adding The SCA To Conventional Coolant/Antifreeze For Maintenance
$V \times 0.014 = X$
V is the total volume of the cooling system.
X is the amount of SCA that is required.

Table 32 is an example for using the equation that is in Table 31.

Table 32

Example Of The Equation For Adding The SCA To Conventional Coolant/Antifreeze For Maintenance		
Total Volume of the Cooling System (V)	Multiplication Factor	Amount of SCA that is Required (X)
946 L (250 US gal)	× 0.014	9 L (4 US gal)

Note: Specific engine applications may require maintenance practices to be periodically evaluated in order to properly maintain the engine's cooling system.

Table 28 lists part numbers and quantities of SCA that is available from your Caterpillar dealer.

Cleaning the System of Heavy-Duty Coolant/Antifreeze

Caterpillar cooling system cleaners are designed to clean the cooling system of harmful scale and corrosion. Caterpillar cooling system cleaners dissolve mineral scale, corrosion products, light oil contamination and sludge.

- Clean the cooling system after used coolant is drained or before the cooling system is filled with new coolant.
- Clean the cooling system whenever the coolant is contaminated or whenever the coolant is foaming.
- For the recommended service interval, refer to the Operation and Maintenance Manual, "Maintenance Interval Schedule" for your engine.

Refill Capacities

i01539748

Refill Capacities

SMCS Code: 1348; 1395; 7560

Lubrication System

The refill capacities for the engine crankcase reflect the approximate capacity of the crankcase or sump plus standard oil filters. Auxiliary oil filter systems will require additional oil. Refer to the OEM specifications for the capacity of the auxiliary oil filter. Refer to the Operation and Maintenance Manual, "Lubricant Specifications" (Maintenance Section) for more information.

Table 33

C-9 Industrial Engine Approximate Refill Capacities		
	Refill Capacity for Changing the Oil and the Filter	
	Liters	Quarts
Oil Sump ⁽¹⁾	31	33

⁽¹⁾ These values should be inserted by the customer as approximate capacities for the crankcase oil sump which include the standard oil filters that are installed at the factory. Engines with auxiliary oil filters will require additional oil. Refer to the OEM specifications for the capacity of the auxiliary oil filter.

Cooling System

To maintain the cooling system, the Total Cooling System capacity must be known. The capacity of the Total Cooling System will vary. The capacity will depend on the size of the radiator (capacity) that is provided by the vehicle manufacturer. Table 34 should be completed by the customer for the maintenance of the cooling system. Refer to the Operation and Maintenance Manual, "Cooling System Specifications" (Maintenance Section) for more information.

Table 34

C-9 Industrial Engine Approximate Refill Capacities		
Compartment or System	Liters	Quarts
Total Cooling System		

i01660955

Maintenance Interval Schedule

SMCS Code: 1000; 7500

Operating conditions and oil API Classifications will determine the amount of service hours for the PM Level 1 Maintenance Interval Schedule. Refer to Operation and Maintenance Manual, "Engine Oil and Filter - Change" for your specific oil change interval.

Note: Ensure that the Safety Information, warnings, and instructions are read and understood before operation or maintenance procedures are performed.

Note: Use fuel consumption, service hours, or calendar time, **whichever occurs first** in order to determine the maintenance intervals. Engines that operate in severe operating conditions may require more frequent maintenance.

Before each consecutive interval is performed, all of the maintenance requirements from the previous interval must also be performed.

When Required

Battery - Replace	76
Battery or Battery Cable - Disconnect	77
Engine Air Cleaner Element (Dual Element) - Clean/Replace	88
Engine Storage Procedure - Check	97
Ether Starting Aid Cylinder - Replace	98
Fuel System - Prime	98
Severe Service Application - Check	107

Daily

Air Tank Moisture and Sediment - Drain	76
Cooling System Coolant Level - Check	84
Driven Equipment - Check	87
Engine Air Cleaner Service Indicator - Inspect	90
Engine Oil Level - Check	92
Fuel System Primary Filter/Water Separator - Drain	99
Power Take-Off Clutch - Check/Adjust/Lubricate	106
Walk-Around Inspection	109

Initial 20 to 40 Service Hours

Belt - Inspect	78
----------------------	----

Every Week

Battery Charger - Check	78
Jacket Water Heater - Check	103

Initial 500 Service Hours

Engine Valve Lash - Inspect/Adjust	97
--	----

Every 6000 Service Hours or 6 Years

Cooling System Coolant (ELC) - Change	82
---	----

PM Level 1 - Every 10 400 L (2750 US gal) of Fuel or 250 Service Hours or 6 Months

Air Compressor Filter - Clean/Replace	75
Battery Electrolyte Level - Check	77
Cooling System Supplemental Coolant Additive (SCA) - Test/Add	85
Engine Oil Sample - Obtain	92
Engine Oil and Filter - Change	93
Fan Drive Bearing - Lubricate	98
Fuel System Primary Filter/Water Separator Element - Replace	100
Fuel System Secondary Filter - Replace	101
Fuel Tank Water and Sediment - Drain	102
Hoses and Clamps - Inspect/Replace	102
Radiator - Clean	107

PM Level 1 - Every 20 800 L (5500 US gal) of Fuel or 500 Service Hours or 6 Months

Air Compressor Filter - Clean/Replace	75
Battery Electrolyte Level - Check	77
Cooling System Supplemental Coolant Additive (SCA) - Test/Add	85
Engine Oil Sample - Obtain	92
Engine Oil and Filter - Change	93
Fan Drive Bearing - Lubricate	98
Fuel System Primary Filter/Water Separator Element - Replace	100
Fuel System Secondary Filter - Replace	101
Fuel Tank Water and Sediment - Drain	102
Hoses and Clamps - Inspect/Replace	102
Radiator - Clean	107

PM Level 2 - Every 83 250 L (22 000 US gal) of Fuel or 2000 Service Hours or 1 Year

Aftercooler Core - Inspect	74
Alternator - Inspect	76
Engine Crankcase Breather - Clean	91
Engine Valve Lash - Inspect/Adjust	97
Engine Valve Rotators - Inspect	97

PM Level 3 - Every 166 500 L (44 000 US gal) of Fuel or 4000 Service Hours or 2 Years

Aftercooler Core - Clean/Test	74
Air Compressor - Inspect	75
Belt Tensioner - Inspect	80
Cooling System Coolant (DEAC) - Change	80
Cooling System Coolant Extender (ELC) - Add	84
Cooling System Water Temperature Regulator - Replace	86
Crankshaft Vibration Damper - Inspect	86

Engine - Clean 87
Engine Mounts - Inspect 91

**Every 340 000 L (90 000 US gal) of Fuel or
10 000 Service Hours**

Cylinder Head Grounding Stud - Inspect/Clean/
Tighten 87
Overhaul Considerations 103

**Every 208 000 L (55 000 US gal) of Fuel or
5000 Service Hours**

Starting Motor - Inspect 108
Turbocharger - Inspect 108
Water Pump - Inspect 110

i01546702

Aftercooler Core - Clean/Test

SMCS Code: 1064-070; 1064-081

1. Remove the core. Refer to the Service Manual for the procedure.
2. Turn the aftercooler core upside-down in order to remove debris.

NOTICE

Do not use a high concentration of caustic cleaner to clean the core. A high concentration of caustic cleaner can attack the internal metals of the core and cause leakage. Only use the recommended concentration of cleaner.

3. Back flush the core with cleaner.

Caterpillar recommends the use of Hydrosolv liquid cleaner. Table 35 lists Hydrosolv liquid cleaners that are available from your Caterpillar dealer.

Table 35

Hydrosolv Liquid Cleaners ⁽¹⁾		
Part Number	Description	Size
1U-5490	Hydrosolv 4165	19 L (5 US gallon)
174-6854	Hydrosolv 100	19 L (5 US gallon)

⁽¹⁾ Use a two to five percent concentration of the cleaner at temperatures up to 93°C (200°F). Refer to Application Guide, NEHS0526 or consult your Caterpillar dealer for more information.

4. Steam clean the core in order to remove any residue. Flush the fins of the aftercooler core. Remove any other trapped debris.
5. Wash the core with hot, soapy water. Rinse the core thoroughly with clean water.

WARNING

Personal injury can result from air pressure.

Personal injury can result without following proper procedure. When using pressure air, wear a protective face shield and protective clothing.

Maximum air pressure at the nozzle must be less than 205 kPa (30 psi) for cleaning purposes.

6. Dry the core with compressed air. Direct the air in the reverse direction of the normal flow.

7. Inspect the core in order to ensure cleanliness. Pressure test the core. Many shops that service radiators are equipped to perform pressure tests. If necessary, repair the core.

8. Install the core. Refer to the Service Manual for the procedure.

For more information on cleaning the core, consult your Caterpillar dealer.

i01468985

Aftercooler Core - Inspect

SMCS Code: 1064-040

Note: Adjust the frequency of cleaning according to the effects of the operating environment.

Inspect the aftercooler for these items: damaged fins, corrosion, dirt, grease, insects, leaves, oil, and other debris. Clean the aftercooler, if necessary.

For air-to-air aftercoolers, use the same methods that are used for cleaning radiators.

WARNING

Personal injury can result from air pressure.

Personal injury can result without following proper procedure. When using pressure air, wear a protective face shield and protective clothing.

Maximum air pressure at the nozzle must be less than 205 kPa (30 psi) for cleaning purposes.

Pressurized air is the preferred method for removing loose debris. Direct the air in the opposite direction of the fan's air flow. Hold the nozzle approximately 6 mm (.25 inch) away from the fins. Slowly move the air nozzle in a direction that is parallel with the tubes. This will remove debris that is between the tubes.

Pressurized water may also be used for cleaning. The maximum water pressure for cleaning purposes must be less than 275 kPa (40 psi). Use pressurized water in order to soften mud. Clean the core from both sides.

Use a degreaser and steam for removal of oil and grease. Clean both sides of the core. Wash the core with detergent and hot water. Thoroughly rinse the core with clean water.

After cleaning, start the engine and accelerate the engine to high idle rpm. This will help in the removal of debris and drying of the core. Stop the engine. Use a light bulb behind the core in order to inspect the core for cleanliness. Repeat the cleaning, if necessary.

Inspect the fins for damage. Bent fins may be opened with a "comb".

Note: If parts of the aftercooler system are repaired or replaced, a leak test is highly recommended. The FT1984 Aftercooler Testing Group is used to perform leak tests on the aftercooler. Refer to the Systems Operation/Testing and Adjusting, "Aftercooler - Test" and the Special Instruction, SEHS8622 for the proper testing procedure.

Inspect these items for good condition: welds, mounting brackets, air lines, connections, clamps, and seals. Make repairs, if necessary.

For more detailed information on cleaning and inspection, see Special Publication, SEBD0518, "Know Your Cooling System".

i01183385

Air Compressor - Inspect

SMCS Code: 1803-040

WARNING

Do not disconnect the air line from the air compressor governor without purging the air brake and the auxiliary air systems. Failure to purge the air brake and the auxiliary air systems before removing the air compressor and/or the air lines could cause personal injury.

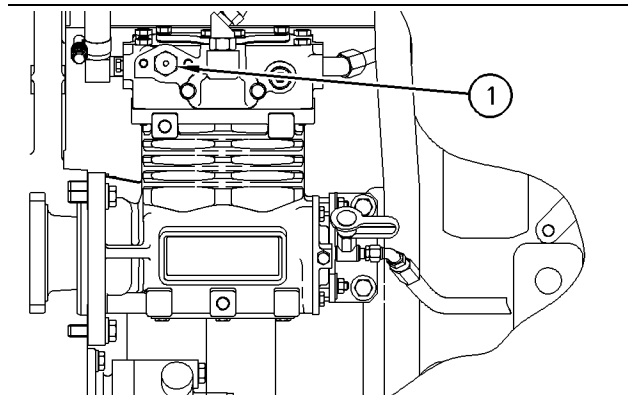

Illustration 31

g00633741

(1) Air compressor pressure relief valve

WARNING

If the air compressor pressure relief valve that is mounted in the air compressor cylinder head is bypassing compressed air, there is a malfunction in the air system, possibly ice blockage. Under these conditions, your engine may have insufficient air for normal brake operation.

Do not operate the engine until the reason for the air bypass is identified and corrected. Failure to heed this warning could lead to property damage, personal injury, or death to the operator or bystanders.

The function of the air compressor pressure relief valve is to bypass air when there is a malfunction in the air compressor system.

The air compressor pressure relief valve releases air at 1723 kPa (250 psi). It is very important that all personnel stand clear of the air compressor pressure relief valve when compressed air is released. All personnel should also stay clear of the air compressor when the engine is operating and the air compressor is exposed.

Refer to the Service Manual or refer to the OEM specifications in order to find information concerning the air compressor. Consult your Caterpillar dealer for assistance.

i01544231

Air Compressor Filter - Clean/Replace (If Equipped)

SMCS Code: 1803-070-FQ; 1803-510-FQ

One of the single most important aspects of preventive maintenance for the air compressor is the induction of clean air. The type of maintenance that is required for the air compressor and the maintenance interval depends on the type of air induction system that is used. Operating conditions (dust, dirt and debris) may require more frequent service.

Refer to the Service Manual for the type of air compressor that is installed on the engine. Follow the maintenance recommendations that are provided by the OEM of the air compressor. Some engines use boost air pressure so the engine air cleaner will require servicing.

i00847451

Air Tank Moisture and Sediment - Drain (If Equipped)

SMCS Code: 1466-543-M&S

Moisture and sediment in the air starting system can cause the following conditions:

- Freezing
- Corrosion of internal parts
- Malfunction of the air starting system

WARNING

When opening the drain valve, wear protective gloves, a protective face shield, protective clothing, and protective shoes. Pressurized air could cause debris to be blown and result in personal injury.

1. Open the drain valve that is on the bottom of the air tank. Allow the moisture and sediment to drain.
2. Close the drain valve.
3. Check the air supply pressure. The air starting motor requires a minimum of 620 kPa (90 psi) of air pressure to operate properly. The maximum air pressure must not exceed 1550 kPa (225 psi). The normal air pressure will be 758 to 965 kPa (110 to 140 psi).

i00072207

Alternator - Inspect

SMCS Code: 1405-040

Caterpillar recommends a scheduled inspection of the alternator. Inspect the alternator for loose connections and proper battery charging. Inspect the ammeter (if equipped) during engine operation in order to ensure proper battery performance and/or proper performance of the electrical system. Make repairs, as required. Refer to the Service Manual.

Check the alternator and the battery charger for proper operation. If the batteries are properly charged, the ammeter reading should be very near zero. All batteries should be kept charged. The batteries should be kept warm because temperature affects the cranking power. If the battery is too cold, the battery will not crank the engine. The battery will not crank the engine, even if the engine is warm. When the engine is not run for long periods of time or if the engine is run for short periods, the batteries may not fully charge. A battery with a low charge will freeze more easily than a battery with a full charge.

i01492550

Battery - Replace

SMCS Code: 1401-510

WARNING

Batteries give off combustible gases which can explode. A spark can cause the combustible gases to ignite. This can result in severe personal injury or death.

Ensure proper ventilation for batteries that are in an enclosure. Follow the proper procedures in order to help prevent electrical arcs and/or sparks near batteries. Do not smoke when batteries are serviced.

WARNING

The battery cables or the batteries should not be removed with the battery cover in place. The battery cover should be removed before any servicing is attempted.

Removing the battery cables or the batteries with the cover in place may cause a battery explosion resulting in personal injury.

1. Turn the key start switch to the OFF position. Remove the key and all electrical loads.
2. Turn OFF the battery charger. Disconnect the charger.
3. The NEGATIVE “-” cable connects the NEGATIVE “-” battery terminal to the ground plane. Disconnect the cable from the NEGATIVE “-” battery terminal.
4. The POSITIVE “+” cable connects the POSITIVE “+” battery terminal to the starting motor. Disconnect the cable from the POSITIVE “+” battery terminal.

Note: Always recycle a battery. Never discard a battery. Return used batteries to an appropriate recycling facility.

5. Remove the used battery.

6. Install the new battery.

Note: Before the cables are connected, ensure that the key start switch is OFF.

7. Connect the cable from the starting motor to the POSITIVE "+" battery terminal.

8. Connect the cable from the ground plane to the NEGATIVE "-" battery terminal.

i01639002

Battery Electrolyte Level - Check

SMCS Code: 1401-535

When the engine is not run for long periods of time or when the engine is run for short periods, the batteries may not fully recharge. Ensure a full charge in order to help prevent the battery from freezing. If batteries are properly charged, ammeter reading should be very near zero.

WARNING

All lead-acid batteries contain sulfuric acid which can burn the skin and clothing. Always wear a face shield and protective clothing when working on or near batteries.

1. Remove the filler caps. Maintain the electrolyte level to the "FULL" mark on the battery.

If the addition of water is necessary, use distilled water. If distilled water is not available use clean water that is low in minerals. Do not use artificially softened water.

2. Check the condition of the electrolyte with the 1U-7298 Coolant/Battery Tester (°C) or the 1U-7297 Coolant/Battery Tester (°F).

3. Keep the batteries clean.

Clean the battery case with one of the following cleaning solutions:

- A mixture of 0.1 kg (0.2 lb) of baking soda and 1 L (1 qt) of clean water

- A mixture of 0.1 L (0.11 qt) of ammonia and 1 L (1 qt) of clean water

Thoroughly rinse the battery case with clean water.

Use a fine grade of sandpaper to clean the terminals and the cable clamps. Clean the items until the surfaces are bright or shiny. DO NOT remove material excessively. Excessive removal of material can cause the clamps to not fit properly. Coat the clamps and the terminals with 5N-5561 Silicone Lubricant, petroleum jelly or MPM grease.

i01492654

Battery or Battery Cable - Disconnect

SMCS Code: 1402-029

WARNING

The battery cables or the batteries should not be removed with the battery cover in place. The battery cover should be removed before any servicing is attempted.

Removing the battery cables or the batteries with the cover in place may cause a battery explosion resulting in personal injury.

1. Turn the start switch to the OFF position. Turn the ignition switch (if equipped) to the OFF position and remove the key and all electrical loads.
2. Disconnect the negative battery terminal at the battery that goes to the start switch. Ensure that the cable cannot contact the terminal. When four 12 volt batteries are involved, the negative side of two batteries must be disconnected.
3. Tape the leads in order to help prevent accidental starting.
4. Proceed with necessary system repairs. Reverse the steps in order to reconnect all of the cables.

i01039758

Battery Charger - Check

SMCS Code: 1401-535

Checking Before Start-Up

Check the battery charger for proper operation. If the batteries are properly charged, the needle of the ammeter will register near "0" (zero).

The battery charger must not produce excessive current during start-up. Alternatively, the charger must be automatically disconnected for start-up. If the engine has an alternator, the charger must be automatically disconnected during start-up and during engine operation.

Charging the Battery

WARNING

Never disconnect any charging unit circuit or battery circuit cable from the battery when the charging unit is operated. A spark can cause an explosion from the flammable vapor mixture of hydrogen and oxygen that is released from the electrolyte through the battery outlets. Injury to personnel can be the result.

Perform the following procedure to charge the battery:

1. Ensure that the charger is turned OFF.
2. Adjust the voltage of the charger in order to match the voltage of the battery.
3. Connect the POSITIVE "+" lead of the charger to the POSITIVE "+" battery terminal. Connect the NEGATIVE "-" lead of the charger to the NEGATIVE "-" battery terminal.
4. Turn ON the battery charger.

Overcharging of Batteries

Overcharging reduces the service life of batteries. Use a battery charger that will not overcharge the battery. DO NOT charge the battery if the meter of the battery charger is in the RED zone.

Overcharging is indicated by the following symptoms:

- The battery is very warm to the touch.
- A strong odor of acid is present.

- The battery emits smoke or a dense vapor (gas).

Perform one of the following procedures if the battery shows symptoms of overcharging:

- Reduce the rate of charging by a significant amount. Complete the charging at the reduced rate.
- Turn OFF the charger.

Table 36 describes the effects of overcharging on different types of batteries.

Table 36

Effects of Overcharging Batteries	
Type of Battery	Effect
Caterpillar General Service Batteries Caterpillar Premium High Output Batteries	All of the battery cells have a low level of electrolyte.
	When the plates of the battery are inspected through the filler holes, the plates may appear to be warped. This is caused by an excessive temperature.
	The battery may not pass a load test.
Caterpillar Maintenance Free Batteries	The battery may not accept a charging current.
	The battery may not pass a load test.

Checking After Stopping

Ensure that the battery charger is connected properly. Observe the meter of the charger. Record the amperage.

i01539754

Belt - Inspect

SMCS Code: 1357-040; 1357; 1397-040; 1397

Inspection

Belt tension should be checked initially between the first 20 to 40 hours of engine operation.

After the initial check, the belt tension should be checked at every oil change.

To maximize the engine performance, inspect the belts for wear and for cracking. Replace belts that are worn or damaged.

For applications that require multiple drive belts, replace the belts in matched sets. Replacing only one belt of a matched set will cause the new belt to carry more load because the older belt is stretched. The additional load on the new belt could cause the new belt to break.

If the belts are too loose, vibration causes unnecessary wear on the belts and pulleys. Loose belts may slip enough to cause overheating.

If the belts are too tight, unnecessary stresses are placed on the pulley bearings and on the belts. This may shorten the service life of the components.

Remove the belt guard, if equipped. Inspect the condition and adjustment of the alternator belts and accessory drive belts (if equipped).

To check the belt tension, apply 110 N (25 lb ft) of force midway between the pulleys. A correctly adjusted belt will deflect 9 mm (0.35 inch) to 15 mm (0.59 inch).

If the belt does not require replacement or adjustment, install the belt guard. If the belt requires adjustment or replacement, perform the following procedure to adjust the belt tension.

Adjustment

Alternator Belt

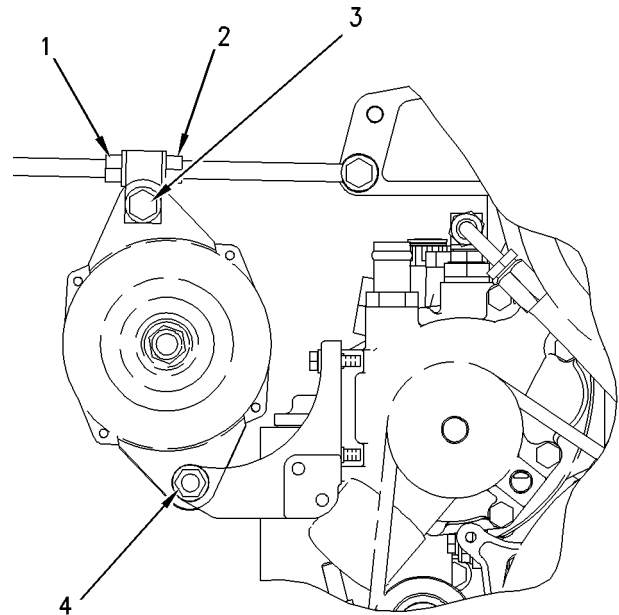

Illustration 32

g00768640

- (1) Nut
- (2) Adjusting Nut
- (3) Bolt
- (4) Nut

1. Slightly loosen mounting bolt (3) and nut (4).
2. Loosen nut (1).
3. Tighten adjusting bolt (2) and mounting bolts (3) and (4). Tighten bolt (1). Refer to the Operation and Maintenance Manual, "Torque Specifications" topic (Maintenance Section).

If new belts are installed, check the belt tension again after 30 minutes of engine operation at the rated rpm.

Water Pump Belt

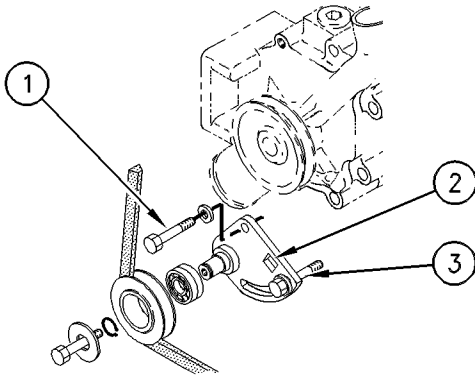

Illustration 33 g00426869

Typical example

Exploded view of the drive assembly for a water pump belt

- (1) Mounting bolt
- (2) Square hole
- (3) Adjusting bolt

1. Slightly loosen mounting bolt (1) and adjusting bolt (3).
2. Adjust the belt tension with a square drive in square hole (2).
3. Tighten adjusting bolt (3) and mounting bolt (1). Refer to the Operation and Maintenance Manual, "Torque Specifications" topic (Maintenance Section).
4. Install the belt guard, if equipped.

If new belts are installed, check the belt tension after 30 minutes of engine operation at the rated rpm.

i01555583

Belt Tensioner - Inspect (If Equipped)

SMCS Code: 1358-040

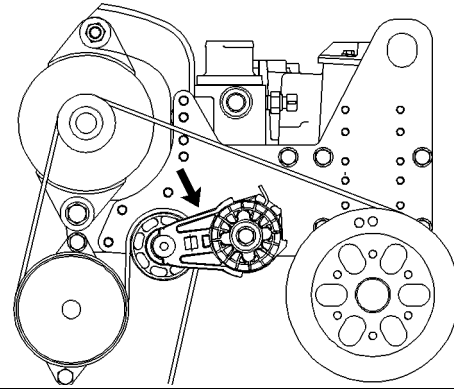

Illustration 34 g00426964

Belt tensioner

Inspect the belt tensioner for unusual noise, excessive looseness and/or shaking of the bearings.

If the belt tensioner should require disassembly, refer to the Service Manual for the procedure.

i01206425

Cooling System Coolant (DEAC) - Change

SMCS Code: 1350-070; 1395-044

Clean the cooling system and flush the cooling system before the recommended maintenance interval if the following conditions exist:

- The engine overheats frequently.
- Foaming is observed.
- The oil has entered the cooling system and the coolant is contaminated.
- The fuel has entered the cooling system and the coolant is contaminated.

NOTICE

Use of commercially available cooling system cleaners may cause damage to cooling system components. Use only cooling system cleaners that are approved for Caterpillar engines.

Note: Inspect the water pump and the water temperature regulator after the cooling system has been drained. This is a good opportunity to replace the water pump, the water temperature regulator and the hoses, if necessary.

Drain

WARNING

Pressurized System: Hot coolant can cause serious burns. To open the cooling system filler cap, stop the engine and wait until the cooling system components are cool. Loosen the cooling system pressure cap slowly in order to relieve the pressure.

1. Stop the engine and allow the engine to cool. Loosen the cooling system filler cap slowly in order to relieve any pressure. Remove the cooling system filler cap.
2. Open the cooling system drain valve (if equipped). If the cooling system is not equipped with a drain valve, remove one of the drain plugs.

Allow the coolant to drain.

NOTICE

Dispose of used engine coolant properly or recycle. Various methods have been proposed to reclaim used coolant for reuse in engine cooling systems. The full distillation procedure is the only method acceptable by Caterpillar to reclaim the used coolant.

For information regarding the disposal and the recycling of used coolant, consult your Caterpillar dealer or consult Caterpillar Service Technology Group:

Outside Illinois: 1-800-542-TOOL
Inside Illinois: 1-800-541-TOOL
Canada: 1-800-523-TOOL

Flush

1. Flush the cooling system with clean water in order to remove any debris.
2. Close the drain valve (if equipped). Clean the drain plugs. Install the drain plugs. Refer to the Operation and Maintenance Manual, "Torque Specifications" topic (Maintenance Section) for more information on the proper torques.

NOTICE

Fill the cooling system no faster than 19 L (5 US gal) per minute to avoid air locks.

3. Fill the cooling system with a mixture of clean water and Caterpillar Fast Acting Cooling System Cleaner. Add 0.5 L (1 pint) of cleaner per 15 L (4 US gal) of the cooling system capacity. Install the cooling system filler cap.
4. Start and run the engine at low idle for a minimum of 30 minutes. The coolant temperature should be at least 82 °C (180 °F).

NOTICE

Improper or incomplete rinsing of the cooling system can result in damage to copper and other metal components.

To avoid damage to the cooling system, make sure to completely flush the cooling system with clear water. Continue to flush the system until all signs of the cleaning agent are gone.

5. Stop the engine and allow the engine to cool. Loosen the cooling system filler cap slowly in order to relieve any pressure. Remove the cooling system filler cap. Open the drain valve (if equipped) or remove the cooling system drain plugs. Allow the water to drain. Flush the cooling system with clean water. Close the drain valve (if equipped). Clean the drain plugs. Install the drain plugs. Refer to the Operation and Maintenance Manual, "Torque Specifications" topic (Maintenance Section) for more information on the proper torques.

Cooling Systems with Heavy Deposits or Plugging

Note: For the following procedure to be effective, there must be some active flow through the cooling system components.

1. Flush the cooling system with clean water in order to remove any debris.
2. Close the drain valve (if equipped). Clean the drain plugs. Install the drain plugs. Refer to the Operation and Maintenance Manual, "Torque Specifications" topic (Maintenance Section) for more information on the proper torques.

NOTICE

Fill the cooling system no faster than 19 L (5 US gal) per minute to avoid air locks.

3. Fill the cooling system with a mixture of clean water and Caterpillar Fast Acting Cooling System Cleaner. Add 0.5 L (1 pint) of cleaner per 3.8 to 7.6 L (1 to 2 US gal) of the cooling system capacity. Install the cooling system filler cap.

4. Start and run the engine at low idle for a minimum of 90 minutes. The coolant temperature should be at least 82 °C (180 °F).

NOTICE

Improper or incomplete rinsing of the cooling system can result in damage to copper and other metal components.

To avoid damage to the cooling system, make sure to completely flush the cooling system with clear water. Continue to flush the system until all signs of the cleaning agent are gone.

5. Stop the engine and allow the engine to cool. Loosen the cooling system filler cap slowly in order to relieve any pressure. Remove the cooling system filler cap. Open the drain valve (if equipped) or remove the cooling system drain plugs. Allow the water to drain. Flush the cooling system with clean water. Close the drain valve (if equipped). Clean the drain plugs. Install the drain plugs. Refer to the Operation and Maintenance Manual, "Torque Specifications" topic (Maintenance Section) for more information on the proper torques.

Fill

NOTICE

Fill the cooling system no faster than 19 L (5 US gal) per minute to avoid air locks.

1. Fill the cooling system with coolant/antifreeze. Refer to the Operation and Maintenance Manual, "Cooling System Specifications" topic (Maintenance Section) for more information on cooling system specifications. Do not install the cooling system filler cap.
2. Start and run the engine at low idle. Increase the engine rpm to 1500 rpm. Run the engine at high idle for one minute in order to purge the air from the cavities of the engine block. Stop the engine.
3. Check the coolant level. Maintain the coolant level within 13 mm (0.5 inch) below the bottom of the pipe for filling. Maintain the coolant level within 13 mm (0.5 inch) to the proper level on the sight glass (if equipped).

4. Clean the cooling system filler cap. Inspect the gasket that is on the cooling system filler cap. If the gasket that is on the cooling system filler cap is damaged, discard the old cooling system filler cap and install a new cooling system filler cap. If the gasket that is on the cooling system filler cap is not damaged, perform a pressure test. A 9S-8140 Pressurizing Pump is used to perform the pressure test. The correct pressure for the cooling system filler cap is stamped on the face of the cooling system filler cap. If the cooling system filler cap does not retain the correct pressure, install a new cooling system filler cap.

5. Start the engine. Inspect the cooling system for leaks and for proper operating temperature.

i01206445

Cooling System Coolant (ELC) - Change

SMCS Code: 1350-070; 1395-044

Clean the cooling system and flush the cooling system before the recommended maintenance interval if the following conditions exist:

- The engine overheats frequently.
- Foaming is observed.
- The oil has entered the cooling system and the coolant is contaminated.
- The fuel has entered the cooling system and the coolant is contaminated.

Note: When the cooling system is cleaned, only clean water is needed when the ELC is drained and replaced.

Note: Inspect the water pump and the water temperature regulator after the cooling system has been drained. This is a good opportunity to replace the water pump, the water temperature regulator and the hoses, if necessary.

Drain



WARNING

Pressurized System: Hot coolant can cause serious burns. To open the cooling system filler cap, stop the engine and wait until the cooling system components are cool. Loosen the cooling system pressure cap slowly in order to relieve the pressure.

1. Stop the engine and allow the engine to cool. Loosen the cooling system filler cap slowly in order to relieve any pressure. Remove the cooling system filler cap.
2. Open the cooling system drain valve (if equipped). If the cooling system is not equipped with a drain valve, remove the cooling system drain plugs.

Allow the coolant to drain.

NOTICE

Dispose of used engine coolant properly or recycle. Various methods have been proposed to reclaim used coolant for reuse in engine cooling systems. The full distillation procedure is the only method acceptable by Caterpillar to reclaim the used coolant.

For information regarding the disposal and the recycling of used coolant, consult your Caterpillar dealer or consult Caterpillar Service Technology Group:

Outside Illinois: 1-800-542-TOOL
Inside Illinois: 1-800-541-TOOL
Canada: 1-800-523-TOOL

Flush

1. Flush the cooling system with clean water in order to remove any debris.
2. Close the drain valve (if equipped). Clean the drain plugs. Install the drain plugs. Refer to the Operation and Maintenance Manual, "Torque Specifications" topic (Maintenance Section) for more information on the proper torques.

NOTICE

Fill the cooling system no faster than 19 L (5 US gal) per minute to avoid air locks.

3. Fill the cooling system with clean water. Install the cooling system filler cap.
4. Start and run the engine at low idle until the temperature reaches 49 to 66 °C (120 to 150 °F).

5. Stop the engine and allow the engine to cool. Loosen the cooling system filler cap slowly in order to relieve any pressure. Remove the cooling system filler cap. Open the drain valve (if equipped) or remove the cooling system drain plugs. Allow the water to drain. Flush the cooling system with clean water. Close the drain valve (if equipped). Clean the drain plugs. Install the drain plugs. Refer to the Operation and Maintenance Manual, "Torque Specifications" topic (Maintenance Section) for more information on the proper torques.

Fill

NOTICE

Fill the cooling system no faster than 19 L (5 US gal) per minute to avoid air locks.

1. Fill the cooling system with Extended Life Coolant (ELC). Refer to the Operation and Maintenance Manual, "Cooling System Specifications" topic (Maintenance Section) for more information on cooling system specifications. Do not install the cooling system filler cap.
2. Start and run the engine at low idle. Increase the engine rpm to high idle. Run the engine at high idle for one minute in order to purge the air from the cavities of the engine block. Stop the engine.
3. Check the coolant level. Maintain the coolant level within 13 mm (0.5 inch) below the bottom of the pipe for filling. Maintain the coolant level within 13 mm (0.5 inch) to the proper level on the sight glass (if equipped).
4. Clean the cooling system filler cap. Inspect the gasket that is on the cooling system filler cap. If the gasket that is on the cooling system filler cap is damaged, discard the old cooling system filler cap and install a new cooling system filler cap. If the gasket that is on the cooling system filler cap is not damaged, use a **9S-8140** Pressurizing Pump in order to pressure test the cooling system filler cap. The correct pressure for the cooling system filler cap is stamped on the face of the cooling system filler cap. If the cooling system filler cap does not retain the correct pressure, install a new cooling system filler cap.
5. Start the engine. Inspect the cooling system for leaks and for proper operating temperature.

i00259474

Cooling System Coolant Extender (ELC) - Add

SMCS Code: 1352-045; 1395-081

Caterpillar Extended Life Coolant (ELC) does not require the frequent Supplemental Coolant Additive (SCA) additions associated with the present conventional coolants. The Extender only needs to be added once.

Check the cooling system only when the engine is stopped and cool.

1. Loosen the cooling system filler cap slowly in order to relieve pressure. Remove the cooling system filler cap.
2. It may be necessary to drain enough coolant from the cooling system in order to add the Extender.
3. Add Extender according to the requirements for your engine's cooling system capacity. Refer to the Operation and Maintenance Manual, "Refill Capacities" in the Maintenance Section for the capacity of the cooling system for your engine. Refer to the Operation and Maintenance Manual, "Cooling System Specifications" information for the Caterpillar ELC Extender additions.
4. Clean the cooling system filler cap. Inspect the cooling system filler cap gaskets. Replace the cooling system filler cap if the cooling system filler cap gaskets are damaged. Install the cooling system filler cap.

i01197583

Cooling System Coolant Level - Check

SMCS Code: 1395-082

Check the coolant level when the engine is stopped and cool.

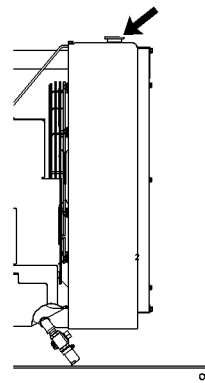

Illustration 35
Cooling system filler cap

g00285520

WARNING

Pressurized System: Hot coolant can cause serious burns. To open the cooling system filler cap, stop the engine and wait until the cooling system components are cool. Loosen the cooling system pressure cap slowly in order to relieve the pressure.

1. Remove the cooling system filler cap slowly in order to relieve pressure.
2. Maintain the coolant level within 13 mm (0.5 inch) of the bottom of the filler pipe. If the engine is equipped with a sight glass, maintain the coolant level to the proper level in the sight glass.

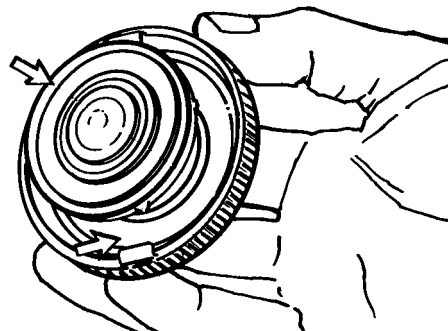

Illustration 36
Typical filler cap gaskets

g00103639

3. Clean the cooling system filler cap and check the condition of the filler cap gaskets. Replace the cooling system filler cap if the filler cap gaskets are damaged. Reinstall the cooling system filler cap.
4. Inspect the cooling system for leaks.

i01463635

Cooling System Supplemental Coolant Additive (SCA) - Test/Add

SMCS Code: 1352-045; 1395-081

WARNING

Cooling system coolant additive contains alkali. To help prevent personal injury, avoid contact with the skin and the eyes. Do not drink cooling system coolant additive.

Note: Test the concentration of the Supplemental Coolant Additive (SCA) or test the SCA concentration as part of an S·O·S Coolant Analysis.

Test for SCA Concentration

Coolant/Antifreeze and SCA

NOTICE

Do not exceed the recommended six percent supplemental coolant additive concentration.

Use the 8T-5296 Coolant Conditioner Test Kit or use the 4C-9301 Coolant Conditioner Test Kit in order to check the concentration of the SCA. Refer to the Operation and Maintenance Manual for more information.

Water and SCA

NOTICE

Do not exceed the recommended eight percent supplemental coolant additive concentration.

Test the concentration of the SCA with the 8T-5296 Coolant Conditioner Test Kit. Refer to the Operation and Maintenance Manual, "Water/Supplemental Coolant Additive (SCA)" topic (Maintenance Section). Refer to the Operation and Maintenance Manual, "Conventional Coolant/Antifreeze Cooling System Maintenance" topic (Maintenance Section).

S·O·S Coolant Analysis

S·O·S coolant samples can be analyzed at your Caterpillar dealer. S·O·S Coolant Analysis is a program that is based on periodic samples.

Level 1

Level 1 is a basic analysis of the coolant. The following items are tested:

- Glycol Concentration
- Concentration of SCA
- pH
- Conductivity

The results are reported, and recommendations are made according to the results. Consult your Caterpillar dealer for information on the benefits of managing your equipment with an S·O·S Coolant Analysis.

Level 2

This level coolant analysis is recommended when the engine is overhauled. Refer to the Operations and Maintenance Manual, "Overhaul Considerations" for further information.

Add the SCA, If Necessary

NOTICE

Do not exceed the recommended amount of supplemental coolant additive concentration. Excessive supplemental coolant additive concentration can form deposits on the higher temperature surfaces of the cooling system, reducing the engine's heat transfer characteristics. Reduced heat transfer could cause cracking of the cylinder head and other high temperature components. Excessive supplemental coolant additive concentration could also result in radiator tube blockage, overheating, and/or accelerated water pump seal wear. Never use both liquid supplemental coolant additive and the spin-on element (if equipped) at the same time. The use of those additives together could result in supplemental coolant additive concentration exceeding the recommended maximum.

WARNING

Pressurized System: Hot coolant can cause serious burns. To open the cooling system filler cap, stop the engine and wait until the cooling system components are cool. Loosen the cooling system pressure cap slowly in order to relieve the pressure.

1. Slowly loosen the cooling system filler cap in order to relieve the pressure. Remove the cooling system filler cap.

Note: Always discard drained fluids according to local regulations.

2. If necessary, drain some coolant from the cooling system into a suitable container in order to allow space for the extra SCA.
3. Add the proper amount of SCA. Refer to the Operation and Maintenance Manual for more information on SCA requirements.
4. Clean the cooling system filler cap. Inspect the gaskets of the cooling system filler cap. If the gaskets are damaged, replace the old cooling system filler cap with a new cooling system filler cap. Install the cooling system filler cap.

i00912898

Cooling System Water Temperature Regulator - Replace

SMCS Code: 1355-510

Replace the water temperature regulator before the water temperature regulator fails. This is a recommended preventive maintenance practice. Replacing the water temperature regulator reduces the chances for unscheduled downtime.

A water temperature regulator that fails in a partially opened position can cause overheating or overcooling of the engine.

A water temperature regulator that fails in the closed position can cause excessive overheating. Excessive overheating could result in cracking of the cylinder head or piston seizure problems.

A water temperature regulator that fails in the open position will cause the engine operating temperature to be too low during partial load operation. Low engine operating temperatures during partial loads could cause an excessive carbon buildup inside the cylinders. This excessive carbon buildup could result in an accelerated wear of the piston rings and wear of the cylinder liner.

NOTICE

Failure to replace your water temperature regulator on a regularly scheduled basis could cause severe engine damage.

Caterpillar engines incorporate a shunt design cooling system and require operating the engine with a water temperature regulator installed.

If the water temperature regulator is installed incorrectly, the engine may overheat, causing cylinder head damage. Ensure that the new water temperature regulator is installed in the original position. Ensure that the water temperature regulator vent hole is open.

Do not use liquid gasket material on the gasket or cylinder head surface.

Refer to the Service Manual for the replacement procedure of the water temperature regulator, or consult your Caterpillar dealer.

Note: If only the water temperature regulators are replaced, drain the coolant from the cooling system to a level that is below the water temperature regulator housing.

i00072369

Crankshaft Vibration Damper - Inspect

SMCS Code: 1205-040

Damage to the crankshaft vibration damper or failure of the crankshaft vibration damper can increase torsional vibrations. This can result in damage to the crankshaft and to other engine components. A deteriorating damper can cause excessive gear train noise at variable points in the speed range.

The damper is mounted to the crankshaft which is located behind the belt guard on the front of the engine.

Removal and Installation

Refer to the Service Manual for the damper removal procedure and for the damper installation procedure.

i00174798

Visconic Damper

The visconic damper has a weight that is located inside a fluid filled case. The weight moves in the case in order to limit torsional vibration. Inspect the damper for evidence of dents, cracks or leaks of the fluid.

Replace the damper if the damper is dented, cracked or leaking. Refer to the Service Manual or consult your Caterpillar dealer for damper replacement.

i01473487

Cylinder Head Grounding Stud - Inspect/Clean/Tighten

SMCS Code: 7423-040; 7423-070; 7423-079

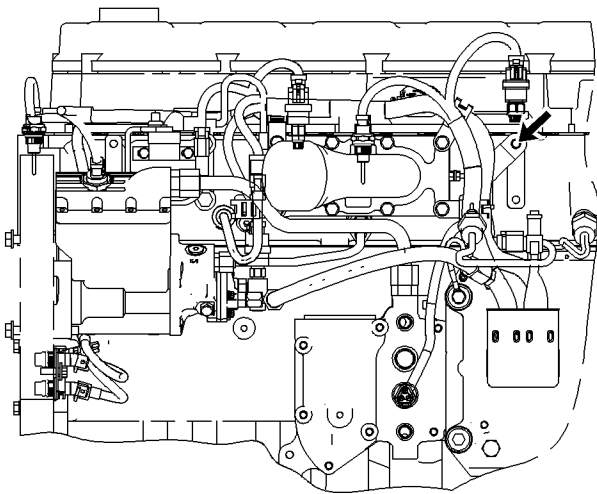

Illustration 37
Typical example

g00768411

Inspect the OEM harness for good connections and condition.

The electrical grounding stud must have a wire ground to the battery. Tighten the electrical grounding stud at every oil change. Ground wires and straps should be combined at engine grounds. All grounds should be tight and free of corrosion.

- If the connections are corroded, clean the connections with a solution of baking soda and water.
- Keep the electrical grounding stud and the strap clean and coated with MPGM grease or petroleum jelly.

Driven Equipment - Check

SMCS Code: 3279-535

Refer to the OEM specifications for more information on the following maintenance recommendations for the driven equipment:

- Inspection
- Adjustment
- Lubrication
- Other maintenance recommendations

Perform any maintenance for the driven equipment which is recommended by the OEM.

i01646701

Engine - Clean

SMCS Code: 1000-070

WARNING

Personal injury or death can result from high voltage.

Moisture can create paths of electrical conductivity.

Make sure that the electrical system is OFF. Lock out the starting controls and tag the controls "DO NOT OPERATE".

NOTICE

Accumulated grease and oil on an engine is a fire hazard. Keep the engine clean. Remove debris and fluid spills whenever a significant quantity accumulates on the engine.

Periodic cleaning of the engine is recommended. Steam cleaning the engine will remove accumulated oil and grease. A clean engine provides the following benefits:

- Easy detection of fluid leaks
- Maximum heat transfer characteristics
- Ease of maintenance

Note: Caution must be used in order to prevent electrical components from being damaged by excessive water when you clean the engine. Avoid electrical components such as the alternator, the starter, and the ECM.

i01553486

Engine Air Cleaner Element (Dual Element) - Clean/Replace

SMCS Code: 1054-037; 1054-510

NOTICE

Never run the engine without an air cleaner element installed. Never run the engine with a damaged air cleaner element. Do not use air cleaner elements with damaged pleats, gaskets or seals. Dirt entering the engine causes premature wear and damage to engine components. Air cleaner elements help to prevent air-borne debris from entering the air inlet.

NOTICE

Never service the air cleaner element with the engine running since this will allow dirt to enter the engine.

Servicing the Air Cleaner Elements

If the air cleaner element becomes plugged, the air can split the material of the air cleaner element. Unfiltered air will drastically accelerate internal engine wear. Your Caterpillar dealer has the proper air cleaner elements for your application. Consult your Caterpillar dealer for the correct air cleaner element.

- Check the precleaner (if equipped) daily for accumulation of dirt and debris. Remove any dirt and debris, as needed.
- Operating conditions (dust, dirt and debris) may require more frequent service of the air cleaner element.
- The air cleaner element may be cleaned up to six times if the element is properly cleaned and inspected.
- The air cleaner element should be replaced at least one time per year. This replacement should be performed regardless of the number of cleanings.

Replace the dirty paper air cleaner elements with clean air cleaner elements. Before installation, the air cleaner elements should be thoroughly checked for tears and/or holes in the filter material. Inspect the gasket or the seal of the air cleaner element for damage. Maintain a supply of suitable air cleaner elements for replacement purposes.

Dual Element Air Cleaners

The dual element air cleaner contains a primary air cleaner element and a secondary air cleaner element. The primary air cleaner element can be used up to six times if the element is properly cleaned and inspected. The primary air cleaner element should be replaced at least one time per year. This replacement should be performed regardless of the number of cleanings.

The secondary air cleaner element is not serviceable or washable. The secondary air cleaner element should be removed and discarded for every three cleanings of the primary air cleaner element. When the engine is operating in environments that are dusty or dirty, air cleaner elements may require more frequent replacement.

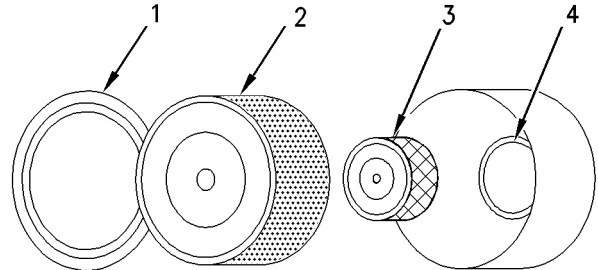

Illustration 38

g00736431

- (1) Cover
- (2) Primary air cleaner element
- (3) Secondary air cleaner element
- (4) Turbocharger air inlet

1. Remove the cover. Remove the primary air cleaner element.
2. The secondary air cleaner element should be removed and discarded for every three cleanings of the primary air cleaner element.

Note: Refer to "Cleaning the Primary Air Cleaner Elements".

3. Cover the turbocharger air inlet with tape in order to keep dirt out.
4. Clean the inside of the air cleaner cover and body with a clean, dry cloth.

5. Remove the tape for the turbocharger air inlet. Install the secondary air cleaner element. Install a primary air cleaner element that is new or cleaned.
6. Install the air cleaner cover.
7. Reset the air cleaner service indicator.

Cleaning the Primary Air Cleaner Elements

NOTICE

Caterpillar recommends certified air filter cleaning services that are available at Caterpillar dealers. The Caterpillar cleaning process uses proven procedures to assure consistent quality and sufficient filter life.

Observe the following guidelines if you attempt to clean the filter element:

Do not tap or strike the filter element in order to remove dust.

Do not wash the filter element.

Use low pressure compressed air in order to remove the dust from the filter element. Air pressure must not exceed 207 kPa (30 psi). Direct the air flow up the pleats and down the pleats from the inside of the filter element. Take extreme care in order to avoid damage to the pleats.

Do not use air filters with damaged pleats, gaskets, or seals. Dirt entering the engine will cause damage to engine components.

The primary air cleaner element can be used up to six times if the element is properly cleaned and inspected. When the primary air cleaner element is cleaned, check for rips or tears in the filter material. The primary air cleaner element should be replaced at least one time per year. This replacement should be performed regardless of the number of cleanings.

Use clean primary air cleaner elements while dirty elements are being cleaned.

NOTICE

Do not clean the air cleaner elements by bumping or tapping. This could damage the seals. Do not use elements with damaged pleats, gaskets or seals. Damaged elements will allow dirt to pass through. Engine damage could result.

Visually inspect the primary air cleaner elements before cleaning. Inspect the air cleaner elements for damage to the seal, the gaskets, and the outer cover. Discard any damaged air cleaner elements.

There are two common methods that are used to clean primary air cleaner elements:

- Pressurized air
- Vacuum cleaning

Pressurized Air

Pressurized air can be used to clean primary air cleaner elements that have not been cleaned more than two times. Pressurized air will not remove deposits of carbon and oil. Use filtered, dry air with a maximum pressure of 207 kPa (30 psi).

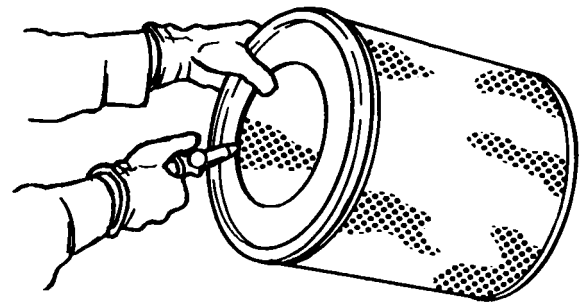

Illustration 39

g00281692

Note: When the primary air cleaner elements are cleaned, always begin with the clean side (inside) in order to force dirt particles toward the dirty side (outside).

Aim the hose so that the air flows inside the element along the length of the filter in order to help prevent damage to the paper pleats. Do not aim the stream of air directly at the primary air cleaner element. Dirt could be forced further into the pleats.

Note: Refer to “Inspecting the Primary Air Cleaner Elements”.

Vacuum Cleaning

Vacuum cleaning is a good method for cleaning primary air cleaner elements which require daily cleaning because of a dry, dusty environment. Cleaning with pressurized air is recommended prior to vacuum cleaning. Vacuum cleaning will not remove deposits of carbon and oil.

Note: Refer to “Inspecting the Primary Air Cleaner Elements”.

Inspecting the Primary Air Cleaner Elements

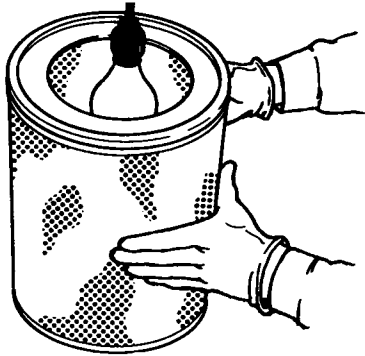

Illustration 40

g00281693

Inspect the clean, dry primary air cleaner element. Use a 60 watt blue light in a dark room or in a similar facility. Place the blue light in the primary air cleaner element. Rotate the primary air cleaner element. Inspect the primary air cleaner element for tears and/or holes. Inspect the primary air cleaner element for light that may show through the filter material. If it is necessary in order to confirm the result, compare the primary air cleaner element to a new primary air cleaner element that has the same part number.

Do not use a primary air cleaner element that has any tears and/or holes in the filter material. Do not use a primary air cleaner element with damaged pleats, gaskets or seals. Discard damaged primary air cleaner elements.

Storing Primary Air Cleaner Elements

If a primary air cleaner element that passes inspection will not be used, the primary air cleaner element can be stored for future use.

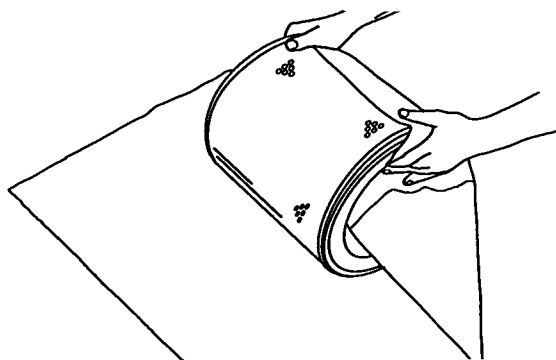

Illustration 41

g00281694

Do not use paint, a waterproof cover, or plastic as a protective covering for storage. An airflow restriction may result. To protect against dirt and damage, wrap the primary air cleaner elements in Volatile Corrosion Inhibited (VCI) paper.

Place the primary air cleaner element into a box for storage. For identification, mark the outside of the box and mark the primary air cleaner element. Include the following information:

- Date of cleaning
- Number of cleanings

Store the box in a dry location.

i01175055

Engine Air Cleaner Service Indicator - Inspect

SMCS Code: 7452-040

Some engines may be equipped with a different service indicator.

Some engines are equipped with a differential gauge for inlet air pressure. The differential gauge for inlet air pressure displays the difference in the pressure that is measured before the air cleaner element and the pressure that is measured after the air cleaner element. As the air cleaner element becomes dirty, the pressure differential rises. If your engine is equipped with a different type of service indicator, follow the OEM recommendations in order to service the air cleaner service indicator.

The service indicator may be mounted on the air cleaner element or in a remote location.

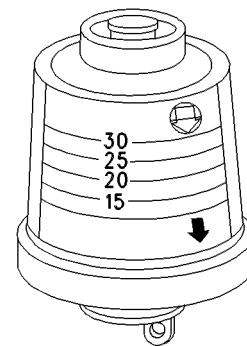

Illustration 42

g00103777

Typical service indicator

Observe the service indicator. The air cleaner element should be cleaned or the air cleaner element should be replaced when one of the following conditions occur:

- The yellow diaphragm enters the red zone.
- The red piston locks in the visible position.

Test the Service Indicator

Service indicators are important instruments.

- Check for ease of resetting. The service indicator should reset in less than three pushes.
- Check the movement of the yellow core when the engine is accelerated to the engine rated speed. The yellow core should latch approximately at the greatest vacuum that is attained.

If the service indicator does not reset easily, or if the yellow core does not latch at the greatest vacuum, the service indicator should be replaced. If the new service indicator will not reset, the hole for the service indicator may be plugged.

The service indicator may need to be replaced frequently in environments that are severely dusty, if necessary. Replace the service indicator annually regardless of the operating conditions. Replace the service indicator when the engine is overhauled, and whenever major engine components are replaced.

Note: When a new service indicator is installed, excessive force may crack the top of the service indicator. Tighten the service indicator to a torque of 2 N·m (18 lb in).

i01473536

Engine Crankcase Breather - Clean

SMCS Code: 1317-070

NOTICE

Perform this maintenance with the engine stopped.

NOTICE

If the crankcase breather is not maintained on a regular basis, it can become plugged. A plugged breather will cause excessive crankcase pressure that may cause crankshaft seal leakage.

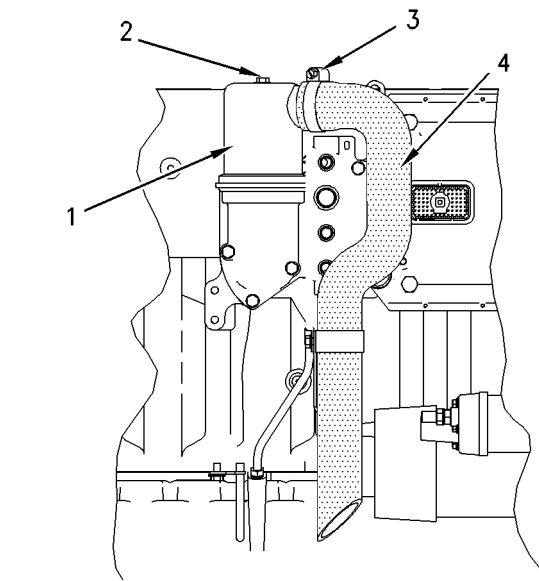

g00768439

Illustration 43

- (1) Breather assembly
- (2) Bolt
- (3) Hose clamp
- (4) Hose

1. Loosen hose clamp (3) and remove hose (4) from breather assembly (1).
2. Remove bolt (2) and the washer. Remove the breather assembly (1) and the seal.
3. Wash the breather element in solvent that is clean and nonflammable. Allow the breather element to dry before installation.
4. Install a breather element that is clean and dry. Install breather assembly (1) and the seal.
5. Install bolt (2) and the washer. Refer to the Operation and Maintenance Manual for the proper torque.
6. Install hose (4) on breather assembly (1). Tighten hose clamp (3). Refer to the Operation and Maintenance Manual, "Torque Specifications" for the proper torques.

i00687861

Engine Mounts - Inspect

SMCS Code: 1152-040

Inspect the engine mounts for deterioration and for proper bolt torque. Engine vibration can be caused by the following conditions:

- Improper mounting of the engine

- Deterioration of the engine mounts

Any engine mount that shows deterioration should be replaced. Refer to the Service Manual for the recommended torques. Refer to your Caterpillar dealer for more information.

i00623423

Engine Oil Level - Check

SMCS Code: 1348-535-FLV

WARNING

Hot oil and hot components can cause personal injury. Do not allow hot oil or hot components to contact the skin.

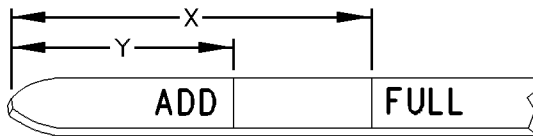

Illustration 44

g00110310

(Y) "ADD" mark. (X) "FULL" mark.

NOTICE

Perform this maintenance with the engine stopped.

1. Maintain the oil level between "ADD" mark (Y) and "FULL" mark (X) on oil level gauge (1). Do not fill the crankcase above "FULL" mark (X).

NOTICE

Operating your engine when the oil level is above the "FULL" mark could cause your crankshaft to dip into the oil. The air bubbles created from the crankshaft dipping into the oil reduces the oil's lubricating characteristics and could result in the loss of power.

2. Remove the oil filler cap and add oil, if necessary. Clean the oil filler cap. Install the oil filler cap.

Engine Oil Sample - Obtain

SMCS Code: 1000-008; 1348-554-SM;
7542-554-OC, SM

In addition to a good preventive maintenance program, Caterpillar recommends using S·O·S oil analysis at regularly scheduled intervals in order to monitor the condition of the engine and the maintenance requirements of the engine.

Obtain the Sample and the Analysis

WARNING

Hot oil and hot components can cause personal injury. Do not allow hot oil or hot components to contact the skin.

Before you take the oil sample, complete the Label, PEEP5031 for identification of the sample. In order to help obtain the most accurate analysis, provide the following information:

- Engine model
- Service hours on the engine
- The number of hours that have accumulated since the last oil change
- The amount of oil that has been added since the last oil change

To ensure that the sample is representative of the oil in the crankcase, obtain a warm, well mixed oil sample.

To avoid contamination of the oil samples, the tools and the supplies that are used for obtaining oil samples must be clean.

Caterpillar recommends using the sampling valve in order to obtain oil samples. The quality and the consistency of the samples are better when the sampling valve is used. The location of the sampling valve allows oil that is flowing under pressure to be obtained during normal engine operation.

The **169-8373** Fluid Sampling Bottle is recommended for use with the sampling valve. The fluid sampling bottle includes the parts that are needed for obtaining oil samples. Instructions are also provided.

NOTICE

Do not use the same vacuum sampling pump for extracting oil samples that is used for extracting coolant samples.

A small residue of either type sample may remain in the pump and may cause a false positive analysis for the sample being taken.

Always use a designated pump for oil sampling and a designated pump for coolant sampling.

Failure to do so may cause a false analysis which could lead to customer and dealer concerns.

If the engine is not equipped with a sampling valve, use the **1U-5718** Vacuum Pump. The pump is designed to accept sampling bottles. Disposable tubing must be attached to the pump for insertion into the sump.

For instructions, see Special Publication, PEHP6001, "How To Take A Good Oil Sample". Consult your Caterpillar dealer for complete information and assistance in establishing an S-O-S program for your engine.

i01730738

Engine Oil and Filter - Change

SMCS Code: 1318-510; 1348-044

Selection of Oil Change Interval

NOTICE

This engine meets EPA Tier 2, Euro Stage II, or MOC Step 2 emission regulations. A 500 hour engine oil change interval is available, provided that operating conditions and recommended multigrade oil types are met. When these requirements are not met, shorten the oil change interval to 250 hours, or use an S-O-S oil sampling and analysis program to determine an acceptable oil change interval.

If you select an interval for oil and filter change that is too long, you may damage the engine.

 **WARNING**

Hot oil and hot components can cause personal injury. Do not allow hot oil or hot components to contact the skin.

Caterpillar oil filters are recommended for oil changes. Recommended multigrade oil types are listed in Table 37. Do not use single grade oils.

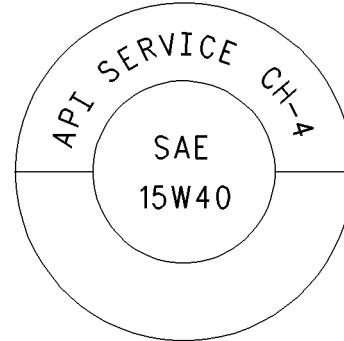

Illustration 45

g00783061

API Trademark

Commercial oils that are licensed by the American Petroleum Institute (API) bear this trademark. Commercial oils that do not bear this trademark are not licensed and these oils are not recommended. Oils that are not listed in Table 37 are not recommended.

Abnormally harsh operating cycles or harsh environments can shorten the service life of the engine oil. Arctic temperatures, corrosive environments, or extremely dusty conditions may require a reduction in engine oil change intervals from the recommendations in Table 37. Poor maintenance of air filters or of fuel filters requires reduced oil change intervals. See your Caterpillar dealer for more information if this product will experience abnormally harsh operating cycles or harsh environments.

Table 37

Oil Change Interval for C-9 Industrial Engine ⁽¹⁾				
Multigrade Oil Type	Operating Conditions			
	Normal ⁽²⁾	High Load Factor above 43 L (11 US gal per hour of fuel) ⁽³⁾	Severe	
			Fuel Sulfur from 0.3% to 0.5% ⁽⁴⁾	Altitude above 1830 m (6000 ft)
Cat DEO Preferred	500 hr	500 hr	500 hr	250 hr ⁽⁶⁾
API CH-4 11.0 minimum TBN ⁽⁴⁾ Preferred	500 hr	500 hr	500 hr	250 hr ⁽⁶⁾
API CH-4 TBN ⁽⁴⁾ below 11.0	500 hr	500 hr	250 hr ⁽⁵⁾	250 hr ⁽⁶⁾
API CG-4	500 hr	250 hr ⁽⁵⁾	250 hr ⁽⁵⁾	250 hr ⁽⁶⁾
API CF-4	250 hr ⁽⁵⁾	250 hr ⁽⁶⁾	250 hr ⁽⁶⁾	250 hr ⁽⁶⁾

- (1) The standard oil change interval in this engine is 500 hours, if the operating conditions and recommended oil types that are listed in this table are met. The traditional oil change interval for engines is 250 hours. Improvements in the engine allow this engine oil change interval. This new standard interval is not permitted for other engines. Refer to the applicable Operation and Maintenance Manuals for the other engines.
- (2) Normal conditions include these factors: Fuel sulfur below 0.3%, altitude below 1830 m (6000 ft), and good air filter and fuel filter maintenance. Normal conditions do not include high load factor, harsh operating cycles, or harsh environments.
- (3) High load factors can shorten the service life of your engine oil. Continuous heavy load cycles and very little idle time result in increased fuel consumption and oil contamination. These factors deplete the oil additives more rapidly. If the average fuel consumption of your engine exceed 43 L (11 US gal) per hour, follow the "High Load Factor" recommendations in Table 37. To determine average fuel consumption for your engine, measure average fuel consumption for a period of 50 to 100 hours. If the application of the engine is changed, the average fuel consumption may change.
- (4) For sulfur content above 0.5%, refer to Operation and Maintenance Manual, "Total Base Number (TBN) and Fuel Sulfur Levels for Direct Injection (DI) Diesel Engines" in the "Lubricant" section of this manual. Also, you may refer to this topic in Manual, SEBU6251.
- (5) In order to verify an oil change interval of 500 hours, refer to "Program A" below.
- (6) Use "Program B" below to determine an appropriate interval.

Adjustment of the Oil Change Interval

Note: Your Caterpillar dealer has additional information on these programs.

Program A

Verification for an Oil Change Interval of 500 Hours

This program consists of three oil change intervals of 500 hours. Oil sampling and analysis is done at 250 hours and 500 hours for each of the three intervals for a total of six oil samples. The analysis includes oil viscosity and infrared (IR) analysis of the oil. If all of the results are satisfactory, the 500 hour oil change interval is acceptable for the engine in that application. Repeat Program A if you change the application of the engine.

If a sample does not pass the oil analysis, take one of these actions:

- Shorten the oil change interval to 250 hours.
- Proceed to Program B.
- Change to a preferred oil type in Table 37.

Program B

Optimizing Oil Change Intervals

Begin with a 250 hour oil change interval. The oil change intervals are adjusted by increments. Each interval is adjusted an additional 50 hours. Periodic oil sampling and analysis is done during each interval. The analysis includes oil viscosity and infrared (IR) analysis of the oil. Repeat Program B if you change the application of the engine.

If an oil sample does not pass the analysis, shorten the oil change interval, or change to a preferred multigrade oil type in the listing above.

References

Reference: Form, PEDP7035, "Optimizing Oil Change Intervals"

Reference: Form, PEDP7036, "S·O·S Fluid Analysis"

Reference: Form, PEDP7076, "Understanding the S·O·S Oil Analysis Tests"

Oil Grade Plug

The Oil Grade Plugs are used on the C-9 Industrial engine to enhance start-up in cold weather conditions. When changing oil grades, the operator must ensure that the corresponding plug is inserted into the wiring harness. The oil grade plugs can be recognized by either the identification tags or by the color of the wires. For the location of the oil grade plug, refer to Operation and Maintenance Manual, "Sensor and Electrical Components".

The following plugs are used to inform the ECM when a particular grade of oil is being used.

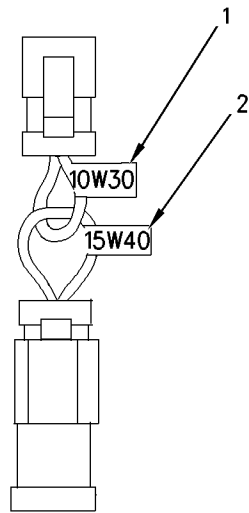

Illustration 46

g00852969

Oil grade plugs being shipped with the engine.

- (1) Identification tag for 10W30 oil grade plug
- (2) Identification tag for 15W40 oil grade plug

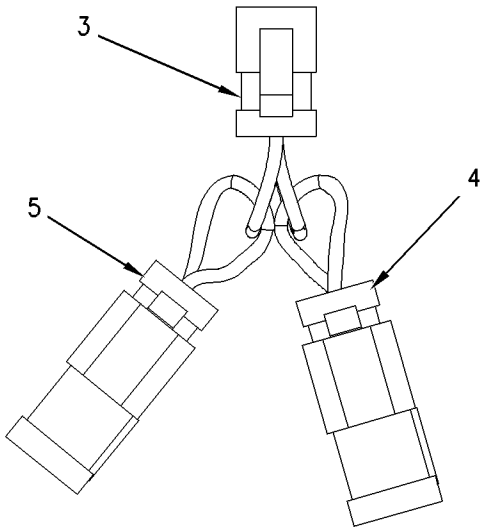

Illustration 47

g00852892

214-7170 Repair Kit

- (3) 10W30 oil grade plug (Green wire)
- (4) 15W40 oil grade plug (Red wire)
- (5) 0W20 oil grade plug (Black wire)

10W30 and 15W40 oil grade plugs are shipped with the engine. The 0W20 oil grade plug can be ordered from the parts manual. Order the 214-7170 Repair Kit. The 0W20 oil grade plug can be made from a 175-3700 Connector Repair Kit. Refer to the Electrical Schematic or refer to Table 38 for the proper pin locations.

Table 38

OIL GRADE PLUGS (214-7170)			
Plug	Oil Grade	Wire Color	Pin Connections
3	10W30	Green	B-C
4	15W40	Red	A-C
5	0W20	Black	A-B-C

Drain the Engine Oil

After the engine has been run at the normal operating temperature, stop the engine. Attach a "DO NOT OPERATE" or a similar warning tag to the ignition keyswitch before the engine is serviced. Catch the oil in a suitable container. Recycle the used oil, or dispose of the used oil properly.

1. Remove the oil drain plug in order to allow the oil to drain.
2. After the oil has drained, the oil drain plug should be cleaned and installed.

Replace the Oil Filter

NOTICE

Caterpillar oil filters are built to Caterpillar specifications. Use of an oil filter not recommended by Caterpillar could result in severe engine damage to the engine bearings, crankshaft, etc., as a result of the larger waste particles from unfiltered oil entering the engine lubricating system. Only use oil filters recommended by Caterpillar.

1. Remove the oil filter with a 185-3630 Strap Wrench.

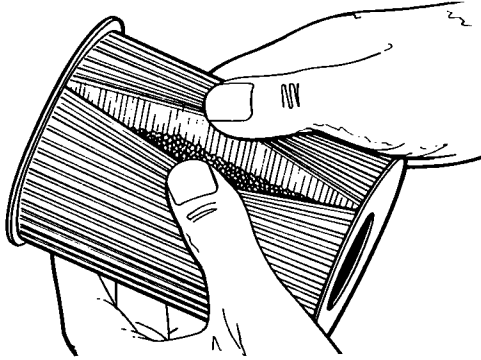

Illustration 48
Element with debris g00588944

2. Cut the oil filter open with a 175-7546 Oil Filter Cutter . Break apart the pleats and inspect the oil filter for metal debris. An excessive amount of metal debris in the oil filter may indicate early wear or a pending failure.

Use a magnet to differentiate between the ferrous metals and the nonferrous metals that are found in the oil filter element. Ferrous metals may indicate wear on the steel and cast iron parts of the engine.

Nonferrous metals may indicate wear on the aluminum parts, brass parts or bronze parts of the engine. Parts that may be affected include the following items: main bearings, rod bearings, turbocharger bearings, and cylinder heads.

Due to normal wear and friction, it is not uncommon to find small amounts of debris in the oil filter. Consult your Caterpillar dealer in order to arrange for a further analysis if an excessive amount of debris is found in the oil filter.

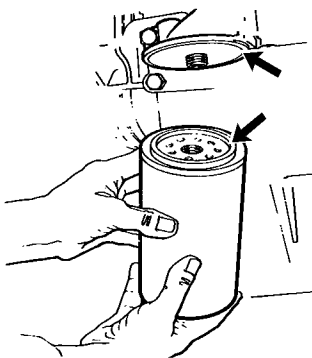

Illustration 49
Typical filter mounting base and filter gasket g00103713

3. Clean the sealing surface of the filter mounting base. Ensure that all of the old oil filter gasket is removed.

4. Apply clean engine oil to the new oil filter gasket.

NOTICE

Do not fill the oil filters with oil before installing them. This oil would not be filtered and could be contaminated. Contaminated oil can cause accelerated wear to engine components.

5. Install the oil filter. Tighten the oil filter until the oil filter gasket contacts the base. Tighten the oil filter by hand according to the instructions that are shown on the oil filter. Do not overtighten the oil filter.

Fill the Engine Crankcase

1. Remove the oil filler cap. Refer to the Operation and Maintenance Manual, "Lubricant Specifications" topic (Maintenance Section) for more information. Fill the crankcase with the proper amount of oil. Refer to the Operation and Maintenance Manual, "Refill Capacities" topic (Maintenance Section) for more information.

NOTICE

If equipped with an auxiliary oil filter or system, extra oil must be added when filling the crankcase. Follow the OEM or filter manufacturer's recommendations. If the extra oil is not added, the engine may starve for oil.

NOTICE

To help prevent crankshaft or bearing damage, crank engine to fill all filters before starting. Do not crank engine for more than 30 seconds.

2. Start the engine and run the engine at "LOW IDLE" for two minutes. Perform this procedure in order to ensure that the lubrication system has oil and that the oil filters are filled. Inspect the oil filter for oil leaks.
3. Stop the engine and allow the oil to drain back to the sump for a minimum of ten minutes.
4. Remove the oil level gauge in order to check the oil level. Maintain the oil level between the "ADD" and "FULL" marks on the "ENGINE STOPPED" side of the oil level gauge.

i01430860

Engine Storage Procedure - Check

SMCS Code: 1000-535

Caterpillar requires all engines that are stored for more than 3 months to follow storage procedures and start-up procedures. These procedures provide maximum protection to internal engine components. Refer to Special Instruction, SEHS9031, "Storage Procedure For Caterpillar Products" for information on these procedures.

An extension of the oil change interval to 12 months is permitted if you follow the required procedures for storage and start-up. This extension is permitted if the following intervals in the Operation and Maintenance Manual, "Maintenance Interval Schedule" have not been reached:

- Operating hours
- Fuel consumption

i00869628

Engine Valve Lash - Inspect/Adjust

SMCS Code: 1102-025

The initial valve lash adjustment on new engines, rebuilt engines, or remanufactured engines is recommended at the first scheduled oil change. The adjustment is necessary due to the initial wear of the valve train components and to the seating of the valve train components.

This maintenance is recommended by Caterpillar as part of a lubrication and preventive maintenance schedule in order to help provide maximum engine life.

NOTICE

Only qualified service personnel should perform this maintenance. Refer to the Service Manual or your Caterpillar dealer for the complete valve lash adjustment procedure.

Operation of Caterpillar engines with improper valve adjustments can reduce engine efficiency. This reduced efficiency could result in excessive fuel usage and/or shortened engine component life.

WARNING

Ensure that the engine can not be started while this maintenance is being performed. To help prevent possible injury, do not use the starting motor to turn the flywheel.

Hot engine components can cause burns. Allow additional time for the engine to cool before measuring/adjusting valve lash clearance.

Ensure that the engine is stopped before measuring the valve lash. To obtain an accurate measurement, allow the valves to cool before this maintenance is performed.

Refer to the Service Manual for more information.

i01597115

Engine Valve Rotators - Inspect

SMCS Code: 1109-040

WARNING

When inspecting the valve rotators, protective glasses or face shield and protective clothing must be worn, to help prevent being burned by hot oil or spray.

Engine valve rotators rotate the valves when the engine runs. This helps to prevent deposits from building up on the valves and the valve seats.

Perform the following steps after the engine valve lash is set, but before the valve covers are installed:

1. Start the engine according to Operation and Maintenance Manual, "Engine Starting" (Operation Section) for the procedure.
2. Operate the engine at low idle.
3. Observe the top surface of each valve rotator. The valve rotators should turn slightly when the valves close.

NOTICE

A valve rotator which does not operate properly will accelerate valve face wear and valve seat wear and shorten valve life. If a damaged rotator is not replaced, valve face guttering could result and cause pieces of the valve to fall into the cylinder. This can cause piston and cylinder head damage.

If a valve fails to rotate, consult your Caterpillar dealer.

i00805059

Ether Starting Aid Cylinder - Replace (If Equipped)

SMCS Code: 1456-510-CD

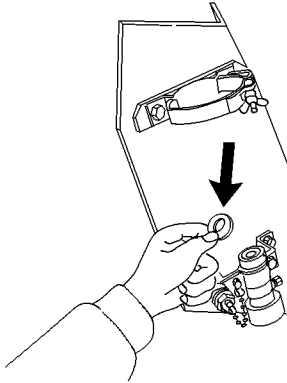

Illustration 50

g00104888

Typical example

1. Loosen the ether cylinder clamp. Unscrew and remove the empty ether cylinder.
2. Remove the used gasket. Install the new gasket that is provided with each new ether cylinder.
3. Install the new ether cylinder. Hand tighten the ether cylinder. Tighten the ether cylinder clamp securely.

i01423301

Fan Drive Bearing - Lubricate

SMCS Code: 1359-086-BD

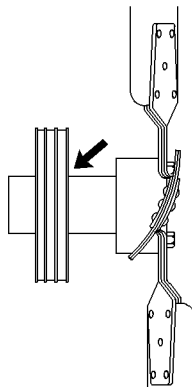

Illustration 51

g00746166

Typical location of the grease fitting that is for the fan drive bearing

The pulley is shown with the belt guards removed

Lubricate the grease fitting that is on the fan drive bearing with Bearing Lubricant or the equivalent.

Inspect the fan drive pulley assembly for wear or for damage. If the shaft is loose, an inspection of the internal components should be performed. Refer to the Service Manual for additional information.

i01091827

Fuel System - Prime

SMCS Code: 1258-548

WARNING

Fuel leaked or spilled onto hot surfaces or electrical components can cause a fire. To help prevent possible injury, turn the start switch off when changing fuel filters or water separator elements. Clean up fuel spills immediately.

NOTICE

Do not allow dirt to enter the fuel system. Thoroughly clean the area around a fuel system component that will be disconnected. Fit a suitable cover over any disconnected fuel system components.

Prime the fuel system in order to fill the fuel filter. Prime the fuel system in order to purge trapped air. The fuel system should be primed under the following conditions:

- Running out of fuel
- Storage
- Replacement of the fuel filter

Engines that are Equipped with a Fuel Priming Pump

NOTICE

Do not loosen the fuel lines at the fuel manifold. The fittings may be damaged and/or a loss of priming pressure may occur when the fuel lines are loosened.

1. Open the fuel priming pump and operate the fuel priming pump until a strong pressure is felt. This procedure will require considerable strokes. Lock the fuel priming pump.

NOTICE

Do not crank the engine continuously for more than 30 seconds. Allow the starting motor to cool for two minutes before cranking the engine again.

- Promptly start the engine. If the engine runs rough, continue to operate the engine at low idle. Do not raise the engine rpm above an idle, until the engine operates smoothly.
- If the engine does not start, open the fuel priming pump and repeat Steps 1 and 2 in order to start the engine.

Engines that are Not Equipped with a Fuel Priming Pump

If the engine is not equipped with a fuel priming pump, you can use the following procedures to prime the fuel system. These procedures will allow only filtered fuel to enter the fuel system.

Fuel Filter Bases that are Equipped with a Plug

NOTICE

Do not allow dirt to enter the fuel system. Thoroughly clean the area around a fuel system component that will be disconnected. Fit a suitable cover over any disconnected fuel system components.

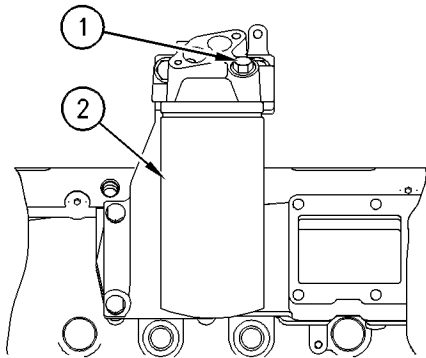

Illustration 52

g00430478

- Plug
- Fuel filter

- Remove plug (1) in order to fill fuel filter (2). Ensure that air is able to vent from the fitting of the plug while the fuel filter is being filled. Clean up any spilled fuel immediately. Clean plug (1). Install plug (1).

NOTICE

Do not crank the engine continuously for more than 30 seconds. Allow the starting motor to cool for two minutes before cranking the engine again.

- Start the engine and operate the engine at low idle. Do not raise the engine speed above an idle, until the engine operates smoothly.

Fuel Filter Bases that are Not Equipped with a Plug

NOTICE

Do not crank the engine continuously for more than 30 seconds. Allow the starting motor to cool for two minutes before cranking the engine again.

- Operate the starting motor. This will fill the fuel filter and the fuel lines with fuel.
- Once the engine starts, operate the engine at low idle. Do not raise the engine speed above an idle, until the engine operates smoothly.

i00259781

Fuel System Primary Filter/Water Separator - Drain

SMCS Code: 1260-543; 1263-543

WARNING

Fuel leaked or spilled onto hot surfaces or electrical components can cause a fire. To help prevent possible injury, turn the start switch off when changing fuel filters or water separator elements. Clean up fuel spills immediately.

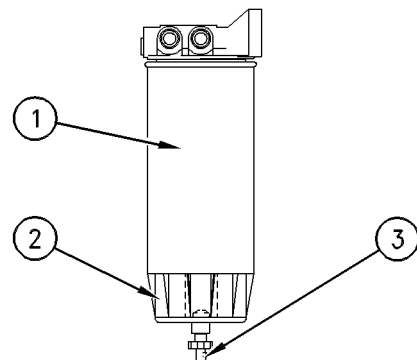

Illustration 53

g00104007

- Element. (2) Bowl. (3) Drain.

Bowl (2) should be monitored daily for signs of water. If water is present, drain the water from the bowl.

- Open drain (3). The drain is a self-ventilated drain. Catch the draining water in a suitable container. Dispose of the water properly.
- Close drain (3).

NOTICE

The water separator is under suction during normal engine operation. Ensure that the drain valve is tightened securely to help prevent air from entering the fuel system.

i01488870

Fuel System Primary Filter/Water Separator Element - Replace

SMCS Code: 1260-510-FQ; 1263-510-FQ

Water in the fuel can cause the engine to run rough. Water in the fuel may cause a electronic unit injector to fail. If the fuel has been contaminated with water, the element should be changed before the regularly scheduled interval.

The primary filter/water separator also provides filtration in order to help extend the life of the secondary fuel filter. The element should be changed regularly. If a vacuum gauge is installed, the primary filter/water separator should be changed at 50 to 70 kPa (15 to 20 inches hg).

Replace the Element

⚠ WARNING

Fuel leaked or spilled onto hot surfaces or electrical components can cause a fire. To help prevent possible injury, turn the start switch off when changing fuel filters or water separator elements. Clean up fuel spills immediately.

Note: A 10 to 15 micron absolute high efficiency fuel filter is required for Caterpillar Electronic Unit Injectors. Caterpillar High Efficiency Fuel Filters meet these requirements. Consult your Caterpillar dealer for the proper part number.

1. Close the main fuel supply valve.

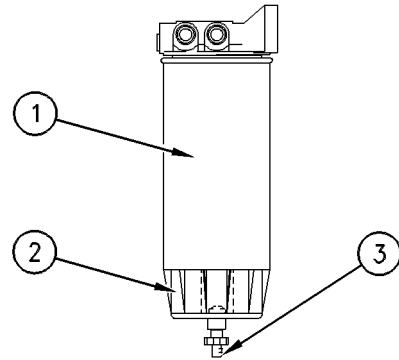

Illustration 54

g00104012

(1) Element. (2) Bowl. (3) Drain.

2. Remove element (1) from the element mounting base while bowl (2) is attached.

NOTICE

Do not allow dirt to enter the fuel system. Thoroughly clean the area around a fuel system component that will be disconnected. Fit a suitable cover over any disconnected fuel system components.

NOTICE

Use a suitable container to catch any fuel that might spill. Clean up any spilled fuel immediately.

3. Dispose of the fuel in the fuel filter element. Remove bowl (2) from element (1). The bowl is reusable. Do not discard the bowl. Dispose of the used element.

4. Remove the O-ring from the gland of the bowl. Clean the following components:

- Bowl
- O-ring
- Mounting base

Inspect the O-ring for damage and for deterioration. Replace the O-ring, if necessary.

5. Lubricate the O-ring with clean diesel fuel.

6. Install bowl (2) on a new element. Tighten the bowl by hand. Do not use tools in order to tighten the bowl.

NOTICE

The primary filter/water separator may be prefilled with fuel to avoid rough running/stalling of the engine due to air. Do not fill the secondary filter with fuel before installation. The fuel would not be filtered and could be contaminated. Contaminated fuel will cause accelerated wear to fuel system parts.

7. Lubricate the top seal of element (1) with clean diesel fuel. The element may be filled with fuel at this time. Install the new element on the mounting base. Tighten the element by hand.
-

NOTICE

The water separator is under suction during normal engine operation. Ensure that the vent plug is tightened securely to help prevent air from entering the fuel system.

8. Open the main fuel supply valve.
9. Start the engine and check for leaks. Run the engine for one minute. Stop the engine and check for leaks again.

Detection of leaks is difficult while the engine is running. The primary filter/water separator is under suction. A leak will allow air to enter the fuel. The air in the fuel can cause low power due to aeration of the fuel. If air enters the fuel, check the components for overtightening or under tightening.

i01503750

Fuel System Secondary Filter - Replace

SMCS Code: 1261-510-SE

 **WARNING**

Fuel leaked or spilled onto hot surfaces or electrical components can cause a fire. To help prevent possible injury, turn the start switch off when changing fuel filters or water separator elements. Clean up fuel spills immediately.

NOTICE

Do not allow dirt to enter the fuel system. Thoroughly clean the area around a fuel system component that will be disconnected. Fit a suitable cover over any disconnected fuel system components.

NOTICE

Use a suitable container to catch any fuel that might spill. Clean up any spilled fuel immediately.

1. Stop the engine. Turn the ignition switch to the OFF position or disconnect the battery. Refer to the Operation and Maintenance Manual, "Battery or Battery Cable - Disconnect" topic (Maintenance Section) for more information. Shut off the fuel supply valve (if equipped).
 2. Remove the used fuel filter and discard the used fuel filter.
 3. Clean the gasket sealing surface of the fuel filter base. Ensure that all of the old gasket is removed.
 4. Apply clean diesel fuel to the new fuel filter gasket.
-

NOTICE

Do not fill the secondary fuel filter with fuel before installing. The fuel would not be filtered and could be contaminated. Contaminated fuel will cause accelerated wear to fuel system parts.

NOTICE

In order to maximize fuel system life and prevent premature wear out from abrasive particles in the fuel, a two micron absolute high efficiency fuel filter is required for all Caterpillar Hydraulic Electronic Unit Injectors. Caterpillar High Efficiency Fuel Filters meet these requirements. Consult your Caterpillar dealer for the proper part numbers.

5. Install the new fuel filter. Spin the fuel filter onto the fuel filter base until the gasket contacts the base. Use the rotation index marks on the filters as a guide for proper tightening. Tighten the filter for an additional one turn (360 degrees) by hand. Do not overtighten the filter.
 6. Open the fuel supply valve. Prime the fuel system. Refer to the Operation and Maintenance Manual, "Fuel System - Prime" topic (Maintenance Section) for more information. Start the engine and inspect the fuel system for leaks.
-

NOTICE

Do not crank the engine continuously for more than 30 seconds. Allow the starting motor to cool for two minutes before cranking the engine again.

Note: There should be enough residual fuel in the cylinder head in order to start the engine. If the engine stops after starting, do not crank the engine for more than 30 seconds. Then allow the starting motor to cool for two minutes. Repeat this procedure until the engine starts and the engine operates.

i00073301

Fuel Tank Water and Sediment - Drain

SMCS Code: 1273-543-M&S

Fuel Tank

Fuel quality is critical to the performance and to the service life of the engine. Water in the fuel can cause excessive fuel system wear. Condensation occurs during the heating and cooling of fuel. The condensation occurs as the fuel passes through the fuel system and the fuel returns to the fuel tank. This causes water to accumulate in fuel tanks. Draining the fuel tank regularly and obtaining fuel from reliable sources can help to eliminate water in the fuel.

Drain the Water and the Sediment

Fuel tanks should contain some provision for draining water and draining sediment from the bottom of the fuel tanks.

Open the drain valve on the bottom of the fuel tank in order to drain the water and the sediment. Close the drain valve.

Check the fuel daily. Drain the water and sediment from the fuel tank after operating the engine or drain the water and sediment from the fuel tank after the fuel tank has been filled. Allow five to ten minutes before performing this procedure.

Fill the fuel tank after operating the engine in order to drive out moist air. This will help prevent condensation. Do not fill the tank to the top. The fuel expands as the fuel gets warm. The tank may overflow.

Some fuel tanks use supply pipes that allow water and sediment to settle below the end of the fuel supply pipe. Some fuel tanks use supply lines that take fuel directly from the bottom of the tank. If the engine is equipped with this system, regular maintenance of the fuel system filter is important.

Fuel Storage Tanks

Drain the water and the sediment from the fuel storage tank during the following conditions:

- Weekly
- Oil change
- Refill of the tank

This will help prevent water or sediment from being pumped from the storage tank into the engine fuel tank.

If a bulk storage tank has been refilled or moved recently, allow adequate time for the sediment to settle before filling the engine fuel tank. Internal baffles in the bulk storage tank will also help trap sediment. Filtering fuel that is pumped from the storage tank helps to ensure the quality of the fuel. When possible, water separators should be used.

i00907072

Hoses and Clamps - Inspect/Replace

SMCS Code: 7554-040; 7554-510

Inspect all hoses for leaks that are caused by the following conditions:

- Cracking
- Softness
- Loose clamps

Replace hoses that are cracked or soft. Tighten any loose clamps.

NOTICE

Do not bend or strike high pressure lines. Do not install bent or damaged lines, tubes or hoses. Repair any loose or damaged fuel and oil lines, tubes and hoses. Leaks can cause fires. Inspect all lines, tubes and hoses carefully. Tighten all connections to the recommended torque.

Check for the following conditions:

- End fittings that are damaged or leaking
- Outer covering that is chafed or cut
- Exposed wire that is used for reinforcement
- Outer covering that is ballooning locally

- Flexible part of the hose that is kinked or crushed
- Armoring that is embedded in the outer covering

A constant torque hose clamp can be used in place of any standard hose clamp. Ensure that the constant torque hose clamp is the same size as the standard clamp.

Due to extreme temperature changes, the hose will heat set. Heat setting causes hose clamps to loosen. This can result in leaks. A constant torque hose clamp will help to prevent loose hose clamps.

Each installation application can be different. The differences depend on the following factors:

- Type of hose
- Type of fitting material
- Anticipated expansion and contraction of the hose
- Anticipated expansion and contraction of the fittings

Replace the Hoses and the Clamps

WARNING

Pressurized System: Hot coolant can cause serious burns. To open the cooling system filler cap, stop the engine and wait until the cooling system components are cool. Loosen the cooling system pressure cap slowly in order to relieve the pressure.

1. Stop the engine. Allow the engine to cool.
 2. Loosen the cooling system filler cap slowly in order to relieve any pressure. Remove the cooling system filler cap.
- Note:** Drain the coolant into a suitable, clean container. The coolant can be reused.
3. Drain the coolant from the cooling system to a level that is below the hose that is being replaced.
 4. Remove the hose clamps.
 5. Disconnect the old hose.
 6. Replace the old hose with a new hose.

Note: For torques on hose clamps, see this Operation and Maintenance Manual, "Torque Specifications" (Maintenance Section).

7. Install the hose clamps with a torque wrench.

Note: For the proper coolant to use, see this Operation and Maintenance Manual, "Coolant Recommendations" (Maintenance Section).

8. Refill the cooling system.
9. Clean the cooling system filler cap. Inspect the cooling system filler cap's gaskets. Replace the cooling system filler cap if the gaskets are damaged. Install the cooling system filler cap.
10. Start the engine. Inspect the cooling system for leaks.

i01042517

Jacket Water Heater - Check

SMCS Code: 1383-535

Jacket water heaters help to improve startability in ambient temperatures that are below 21 °C (70 °F). All installations that require automatic starting should have jacket water heaters.

Check the operation of the jacket water heater. For an ambient temperature of 0 °C (32 °F), the heater should maintain the jacket water temperature at approximately 32 °C (90 °F).

i01452713

Overhaul Considerations

SMCS Code: 7595-043

Reduced hours of operation at full load will result in a lower average power demand. A decreased average power demand should increase both the engine service life and the overhaul interval.

The need for an overhaul is generally indicated by increased fuel consumption and by reduced power.

The following factors are important when a decision is being made on the proper time for an engine overhaul:

- The need for preventive maintenance
- The quality of the fuel that is being used
- The operating conditions
- The results of the S-O-S analysis

Oil Consumption as an Overhaul Indicator

Oil consumption, fuel consumption, and maintenance information can be used to estimate the total operating cost for your Caterpillar engine. Oil consumption can also be used to estimate the required capacity of a makeup oil tank that is suitable for the maintenance intervals.

Oil consumption is in proportion to the percentage of the rated engine load. As the percentage of the engine load is increased, the amount of oil that is consumed per hour also increases.

The oil consumption rate (brake specific oil consumption) is measured in grams per kW/h (lb per bhp). The brake specific oil consumption (BSOC) depends on the engine load. Consult your Caterpillar dealer for assistance in determining the typical oil consumption rate for your engine.

When an engine's oil consumption has risen to three times the original oil consumption rate due to normal wear, an engine overhaul should be scheduled. There may be a corresponding increase in blowby and a slight increase in fuel consumption.

Overhaul Options

Before Failure Overhaul

A planned overhaul before failure may be the best value for the following reasons:

- Costly unplanned downtime can be avoided.
- Many original parts can be reused according to the standards for reusable parts.
- The engine's service life can be extended without the risk of a major catastrophe due to engine failure.
- The best cost/value relationship per hour of extended life can be attained.

After Failure Overhaul

If a major engine failure occurs and the engine must be removed, many options are available. An overhaul should be performed if the engine block or the crankshaft needs to be repaired.

If the engine block is repairable and/or the crankshaft is repairable, the overhaul cost should be between 40 percent and 50 percent of the cost of a new engine with a similar exchange core.

This lower cost can be attributed to three aspects:

- Specially designed Caterpillar engine features
- Caterpillar dealer exchange components
- Caterpillar Inc. remanufactured exchange components

Overhaul Recommendation

To minimize downtime, Caterpillar Inc. recommends a scheduled engine overhaul by your Caterpillar dealer before the engine fails. This will provide you with the best cost/value relationship.

Note: Overhaul programs vary according to the engine application and according to the dealer that performs the overhaul. Consult your Caterpillar dealer for specific information about the available overhaul programs and about overhaul services for extending the engine life.

If an overhaul is performed without overhaul service from your Caterpillar dealer, be aware of the following maintenance recommendations.

Rebuild or Exchange

Cylinder Head Assembly, Cylinder Packs, Oil Pump, and Fuel Transfer Pump

These components should be inspected according to the instructions that are found in various Caterpillar reusability publications. The Special Publication, SEBF8029 lists the reusability publications that are needed for inspecting the engine parts.

If the parts comply with the established inspection specifications that are expressed in the reusable parts guideline, the parts should be reused.

Parts that are not within the established inspection specifications should be dealt with in one of the following manners:

- Salvaging
- Repairing
- Replacing

Using out-of-spec parts can result in the following problems:

- Unscheduled downtime
- Costly repairs
- Damage to other engine parts
- Reduced engine efficiency

- Increased fuel consumption

Reduced engine efficiency and increased fuel consumption translates into higher operating costs. Therefore, Caterpillar Inc. recommends repairing out-of-spec parts or replacing out-of-spec parts.

Inspection and/or Replacement

Crankshaft Bearings, Valve Rotators, and Crankshaft Seals

The following components may not last until the second overhaul.

- Thrust bearings
- Main bearings
- Rod bearings
- Valve rotators
- Crankshaft seals

Caterpillar Inc. recommends the installation of new parts at each overhaul period.

Inspect these parts while the engine is disassembled for an overhaul.

Inspect the crankshaft for any of the following conditions:

- Deflection
- Damage to the journals
- Bearing material that has seized to the journals

Check the journal taper and the profile of the crankshaft journals. Check these components by interpreting the wear patterns on the following components:

- Rod bearing
- Main bearings

Inspect the camshaft for damage to the journals and to the lobes.

Note: If the camshaft is removed for any reason, use the magnetic particle inspection process to check for cracks in the camshaft.

Inspect the following components for signs of wear or for signs of scuffing:

- Camshaft bearings

- Camshaft followers

Caterpillar Inc. recommends replacing the crankshaft vibration damper.

Oil Cooler Core

During an overhaul, Caterpillar Inc. recommends the removal of the oil cooler core. Clean the oil cooler core. Then, pressure test the oil cooler core.

NOTICE

Do not use caustic cleaners to clean the core.

Caustic cleaners can attack the internal metals of the core and cause leakage.

Note: Use this cleaning procedure to clean the oil cooler core.

1. Remove the oil cooler core.
2. Remove any debris from the oil cooler core. To remove debris from the oil cooler core, turn the oil cooler core onto one end.
3. Flush the oil cooler core internally with cleaner in order to loosen foreign substances. This will also help to remove oil from the oil cooler core.

Note: Caterpillar Inc. recommends the use of Hydrosolv Liquid Cleaners. Table 39 lists the Hydrosolv Liquid Cleaners that are available from your Caterpillar dealer.

Table 39

Hydrosolv Liquid Cleaners		
Part Number	Description	Size
1U-8812	Hydrosolv4165	4 L (1 US gallon)
1U-5490		19 L (5 US gallon)
8T-7570		208 L (55 US gallon)
1U-8804	Hydrosolv100	4 L (1 US gallon)
1U-5492		19 L (5 US gallon)
8T-5571		208 L (55 US gallon)

4. Use steam to clean the oil cooler core. This removes any remaining residue from the cleaner. Flush the fins of the oil cooler core. Remove any other trapped debris.
5. Wash the oil cooler core with hot, soapy water. Rinse the oil cooler core thoroughly with clean water.

⚠ WARNING

Personal injury can result from air pressure.

Personal injury can result without following proper procedure. When using pressure air, wear a protective face shield and protective clothing.

Maximum air pressure at the nozzle must be less than 205 kPa (30 psi) for cleaning purposes.

6. Dry the oil cooler core with compressed air. Direct the air in the reverse direction of the normal flow.
7. Inspect the components in order to ensure cleanliness. The oil cooler core should be pressure tested. Repair the oil cooler core, if necessary. Install the oil cooler core.

For more information about cleaning the cores, consult your Caterpillar dealer.

Obtain Coolant Analysis

The concentration of supplemental coolant additive (SCA) should be checked regularly with test kits or with S-O-S Coolant Analysis (Level 1). Further coolant analysis is recommended when the engine is overhauled.

For example, considerable deposits are found in the water jacket areas on the external cooling system, but the concentrations of coolant additives were carefully maintained. The coolant water probably contained minerals that were deposited on the engine over time.

A coolant analysis can be conducted in order to verify the condition of the water that is being used in the cooling system. A full water analysis can be obtained by consulting your local water utility company or an agricultural agent. Private laboratories are also available for water analysis.

Caterpillar Inc. recommends an S-O-S Coolant Analysis (Level 2).

S-O-S Coolant Analysis (Level 2)

An S-O-S Coolant Analysis (Level 2) is a comprehensive coolant analysis which completely analyzes the coolant and the effects on the cooling system. An S-O-S Coolant Analysis (Level 2) provides the following information:

- Complete S-O-S Coolant Analysis (Level 1)
- Visual inspection of properties

- Identification of metal corrosion
- Identification of contaminants
- Identification of built up impurities (corrosion and scale)

S-O-S Coolant Analysis (Level 2) provides a report of the results of both the analysis and the maintenance recommendations.

For more information about coolant analysis, see your Caterpillar dealer.

i01506009

Power Take-Off Clutch - Check/Adjust/Lubricate

SMCS Code: 3055-036; 3055-086

NOTICE

New power take-offs should have the clutch adjustment checked before being placed into service. The clutch adjustment should be checked again after the first ten hours of operation. New clutch plates have a "wear in" period, and the clutch may require several adjustments until the new plates are "worn in".

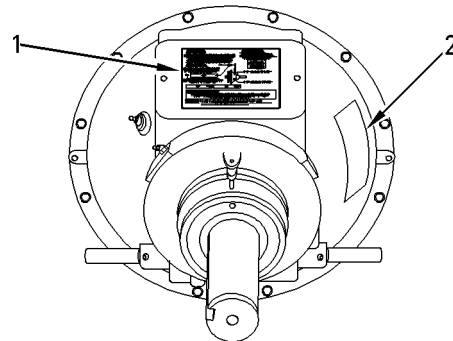

Illustration 55

g00781502

- (1) Instruction plate
- (2) Serial number plate

Check the clutch adjustment regularly after "wear in". Heavy-duty applications which have engagements that are frequent and relatively long periods of clutch slippage require more frequent adjustment than light-duty applications. The operating torque should be measured in order to determine if a clutch adjustment is required.

Refer to the OEM information and instruction plate (1) for instructions on lubrication, adjustment, and other recommendations for service. Perform the maintenance that is specified on the instruction plate.

 **WARNING**

Do not operate the engine with the Instruction Plate cover removed from the clutch. Personal injury may result.

If the clutch is damaged to the point of burst failure, expelled pieces can cause personal injury to anyone in the immediate area. Proper safeguards must be followed to help prevent accidents.

i01604510

Radiator - Clean

SMCS Code: 1353-070

Note: Adjust the frequency of cleaning according to the effects of the operating environment.

Inspect the radiator for these items: damaged fins, corrosion, dirt, grease, insects, leaves, oil, and other debris. Clean the radiator, if necessary.

 **WARNING**

Personal injury can result from air pressure.

Personal injury can result without following proper procedure. When using pressure air, wear a protective face shield and protective clothing.

Maximum air pressure at the nozzle must be less than 205 kPa (30 psi) for cleaning purposes.

Pressurized air is the preferred method for removing loose debris. Direct the air in the opposite direction of the fan's air flow. Hold the nozzle approximately 6 mm (0.25 inch) away from the fins. Slowly move the air nozzle in a direction that is parallel with the tubes. This will remove debris that is between the tubes.

Pressurized water may also be used for cleaning. The maximum water pressure for cleaning purposes must be less than 275 kPa (40 psi). Use pressurized water in order to soften mud. Clean the core from both sides.

Use a degreaser and steam for removal of oil and grease. Clean both sides of the core. Wash the core with detergent and hot water. Thoroughly rinse the core with clean water.

After cleaning, start the engine and accelerate the engine to high idle rpm. This will help in the removal of debris and drying of the core. Stop the engine. Use a light bulb behind the core in order to inspect the core for cleanliness. Repeat the cleaning, if necessary.

Inspect the fins for damage. Bent fins may be opened with a "comb". Inspect these items for good condition: welds, mounting brackets, air lines, connections, clamps, and seals. Make repairs, if necessary.

For more detailed information on cleaning and inspection, refer to Special Publication, SEBD0518, "Know Your Cooling System".

i00151038

Severe Service Application - Check

SMCS Code: 1000-535

Severe service is an application of an engine that exceeds current published standards for that engine. Caterpillar maintains standards for the following engine parameters:

- Performance (power range, speed range, and fuel consumption)
- Fuel quality
- Altitude range
- Maintenance intervals
- Oil selection and maintenance
- Coolant selection and maintenance
- Environmental qualities
- Installation

Refer to the standards for the engine or consult with your Caterpillar dealer in order to determine if the engine is operating within the defined parameters.

Severe service operation can accelerate component wear. Engines that operate under severe conditions may need more frequent maintenance intervals in order to ensure maximum reliability and retention of full service life.

Due to individual applications, it is not possible to identify all of the factors which can contribute to severe service operation. Consult your Caterpillar dealer for the unique maintenance that is necessary for the engine.

The operating environment, improper operating procedures and improper maintenance procedures can be factors which contribute to severe service conditions.

Environmental Factors

Ambient temperatures – The engine may be exposed to extended operation in extremely cold environments or hot environments. Valve components can be damaged by carbon buildup if the engine is frequently started and stopped in very cold temperatures. Extremely hot inlet air reduces engine performance.

Air Quality – The engine may be exposed to extended operation in an environment that is dirty or dusty, unless the equipment is cleaned regularly. Mud, dirt and dust can encase components. Maintenance can be very difficult. The buildup can contain corrosive chemicals.

Buildup – Compounds, elements, corrosive chemicals and salt can damage some components.

Altitude – Problems can arise when the engine is operated at altitudes that are higher than the intended settings for that application. Necessary adjustments should be made.

Improper Operating Procedures

- Extended operation at low idle
- Frequent hot shutdowns
- Operating at excessive loads
- Operating at excessive speeds
- Operating outside the intended application

Improper Maintenance Procedures

- Extending the maintenance intervals
- Failure to use recommended fuel, lubricants and coolant/antifreeze

i00651416

Starting Motor - Inspect

SMCS Code: 1451-040; 1453-040

Caterpillar Inc. recommends a scheduled inspection of the starting motor. If the starting motor fails, the engine may not start in an emergency situation.

Check the starting motor for proper operation. Check the electrical connections and clean the electrical connections. Refer to the Service Manual for more information on the checking procedure and for specifications or consult your Caterpillar dealer for assistance.

i01539769

Turbocharger - Inspect

SMCS Code: 1052-040

Periodic inspection and cleaning is recommended for the turbocharger compressor housing (inlet side). Any fumes from the crankcase are filtered through the air inlet system. Therefore, by-products from oil and from combustion can collect in the turbocharger compressor housing. Over time, this buildup can contribute to loss of engine power, increased black smoke and overall loss of engine efficiency.

If the turbocharger fails during engine operation, damage to the turbocharger compressor wheel and/or to the engine may occur. Damage to the turbocharger compressor wheel can cause additional damage to the pistons, the valves, and the cylinder head.

NOTICE

Turbocharger bearing failures can cause large quantities of oil to enter the air inlet and exhaust systems. Loss of engine lubricant can result in serious engine damage.

Minor leakage of a turbocharger housing under extended low idle operation should not cause problems as long as a turbocharger bearing failure has not occurred.

When a turbocharger bearing failure is accompanied by a significant engine performance loss (exhaust smoke or engine rpm up at no load), do not continue engine operation until the turbocharger is repaired or replaced.

An inspection of the turbocharger can minimize unscheduled downtime. An inspection of the turbocharger can also reduce the chance for potential damage to other engine parts.

Note: Turbocharger components require precision clearances. The turbocharger cartridge must be balanced due to high rpm. Severe Service Applications can accelerate component wear. Severe Service Applications require more frequent inspections of the cartridge.

Removal and Installation

For options regarding the removal, installation, repair and replacement, consult your Caterpillar dealer. Refer to the Service Manual for this engine for the procedure and specifications.

Cleaning and Inspecting

1. Remove the exhaust outlet piping and remove the air inlet piping from the turbocharger. Visually inspect the piping for the presence of oil. Clean the interior of the pipes in order to prevent dirt from entering during reassembly.
2. Turn the compressor wheel and the turbine wheel by hand. The assembly should turn freely. Inspect the compressor wheel and the turbine wheel for contact with the turbocharger housing. There should not be any visible signs of contact between the turbine wheel or compressor wheel and the turbocharger housing. If there is any indication of contact between the rotating turbine wheel or the compressor wheel and the turbocharger housing, the turbocharger must be reconditioned.
3. Check the compressor wheel for cleanliness. If only the blade side of the wheel is dirty, dirt and/or moisture is passing through the air filtering system. If oil is found only on the back side of the wheel, there is a possibility of a failed turbocharger oil seal.

The presence of oil may be the result of extended engine operation at low idle. The presence of oil may also be the result of a restriction of the line for the inlet air (plugged air filters), which causes the turbocharger to slobber.
4. Use a dial indicator to check the end clearance on the shaft. If the measured end play is greater than the Service Manual specifications, the turbocharger should be repaired or replaced. An end play measurement that is less than the minimum Service Manual specifications could indicate carbon buildup on the turbine wheel. The turbocharger should be disassembled for cleaning and for inspection if the measured end play is less than the minimum Service Manual specifications.
5. Inspect the bore of the turbine housing for corrosion.
6. Clean the turbocharger housing with standard shop solvents and a soft bristle brush.
7. Fasten the air inlet piping and the exhaust outlet piping to the turbocharger housing.

Walk-Around Inspection

SMCS Code: 1000-040

Inspect the Engine for Leaks and for Loose Connections

A walk-around inspection should only take a few minutes. When the time is taken to perform these checks, costly repairs and accidents can be avoided.

For maximum engine service life, make a thorough inspection of the engine compartment before starting the engine. Look for items such as oil leaks or coolant leaks, loose bolts, worn belts, loose connections and trash buildup. Make repairs, as needed:

- The guards must be in the proper place. Repair damaged guards or replace missing guards.
- Wipe all caps and plugs before the engine is serviced in order to reduce the chance of system contamination.

NOTICE

For any type of leak (coolant, lube, or fuel) clean up the fluid. If leaking is observed, find the source and correct the leak. If leaking is suspected, check the fluid levels more often than recommended until the leak is found or fixed, or until the suspicion of a leak is proved to be unwarranted.

NOTICE

Accumulated grease and/or oil on an engine or deck is a fire hazard. Remove this debris with steam cleaning or high pressure water.

- Ensure that the cooling lines are properly clamped and that the cooling lines are tight. Check for leaks. Check the condition of all pipes.
- Inspect the water pumps for coolant leaks.

Note: The water pump seal is lubricated by coolant in the cooling system. It is normal for a small amount of leakage to occur as the engine cools down and the parts contract.

Excessive coolant leakage may indicate the need to replace the water pump seal. For the removal of water pumps and the installation of water pumps and/or seals, refer to the Service Manual for the engine or consult your Caterpillar dealer.

- Inspect the lubrication system for leaks at the front crankshaft seal, the rear crankshaft seal, the oil pan, the oil filters and the valve cover.
- Inspect the fuel system for leaks. Look for loose fuel line clamps or for loose fuel line tie-wraps.
- Inspect the piping for the air inlet system and the elbows for cracks and for loose clamps. Ensure that hoses and tubes are not contacting other hoses, tubes, wiring harnesses, etc.
- Inspect the alternator belt and the accessory drive belts for cracks, breaks or other damage.

Belts for multiple groove pulleys must be replaced as matched sets. If only one belt is replaced, the belt will carry more load than the belts that are not replaced. The older belts are stretched. The additional load on the new belt could cause the belt to break.

- Drain the water and the sediment from fuel tanks on a daily basis in order to ensure that only clean fuel enters the fuel system.
- Inspect the wiring and the wiring harnesses for loose connections and for worn wires or frayed wires.
- Inspect the ground strap for a good connection and for good condition.
- Inspect the ECM to the cylinder head ground strap for a good connection and for good condition.
- Disconnect any battery chargers that are not protected against the current drain of the starting motor. Check the condition and the electrolyte level of the batteries, unless the engine is equipped with a maintenance free battery.
- Check the condition of the gauges. Replace any gauges that are cracked. Replace any gauge that can not be calibrated.

- Other potential damage to the engine

Visually inspect the water pump for leaks. If any leaking is observed, replace the water pump seal or the water pump assembly. Refer to the Service Manual for the disassembly and assembly procedure.

Note: Refer to the Service Manual or consult your Caterpillar dealer if any repair is needed or any replacement is needed.

i01057943

Water Pump - Inspect

SMCS Code: 1361-040; 1361

A failed water pump might cause severe engine overheating problems that could result in the following conditions:

- Cracks in the cylinder head
- A piston seizure

Warranty Section

Warranty Information

i01087950

Emissions Warranty Information

SMCS Code: 1000

This engine may be certified to comply with exhaust emission standards and gaseous emission standards that are prescribed by law at the time of manufacture, and this engine may be covered by an Emissions Warranty. A detailed explanation of the Emissions Warranty that is applicable to emissions certified engines is found in Supplement, SEBU6981, "Federal Emissions Control Warranty Information". Consult your authorized Caterpillar dealer to determine if your engine is emissions certified and if your engine is subject to an Emissions Warranty.

Reference Information Section

Engine Ratings

i00727327

Engine Rating Conditions

SMCS Code: 1000

All engine ratings are in compliance with the following standard ambient air conditions of "SAE J1349":

- 99 kPa (29.3 inches of Hg)
- 30 percent relative humidity
- A temperature of 25 °C (77 °F)

Ratings relate to the standard conditions of "ISO8665", of "ISO3046/1", of "DIN6271", and of "BS5514".

The engine ratings are based on the following fuel specifications:

- Low heat value (LHV) of the fuel of 42 780 kJ/kg (18,390 Btu/lb) at 29 °C (84 °F)
- Gravity (API) of 35 degrees at 15 °C (60 °F)
- Specific gravity of .849 at 15 °C (60 °F)
- Density of 850 kg/m³ (7.085 lb/US gal)

The engine ratings are gross output ratings.

Gross Output Ratings – The total output capability of the engine that is equipped with standard accessories.

Standard accessories include the following components:

- Oil pumps
- Fuel pumps
- Water pumps

Subtract the power that is required to drive auxiliary components from the gross output. This will produce the net power that is available for the external load (flywheel).

i00819749

Engine Rating Definitions

SMCS Code: 1000

It is important to know the use of the engine so that the rating will match the operating profile. The proper rating selection is also important so that the customer's perception of price and value is realized.

In selecting a rating for a specific application, the most important consideration is the time that is spent at full throttle. These rating definitions identify the percent of time at full throttle. The definitions also identify the corresponding times below rated rpm.

Note: The examples of the applications are only for reference. For an exact determination of the appropriate rating, follow the OEM specifications or consult your Caterpillar dealer.

A Rating – This rating is used for heavy-duty applications that are operated at rated load and at rated rpm up to 100 percent. This rating is used for engines that operate without interruption of load cycling. Typical applications include the following examples: pipeline pumping and ventilation.

B Rating – This rating is used when power and/or rpm are cyclic. The engine should be run at full load. The engine should not exceed 80 percent of the duty cycle. Typical applications include the following examples: irrigation, operation where normal pump demand is 85 percent of the engine rating, oil pumping/drilling, field mechanical pumping/drilling, and stationary/plant air compressors.

C Rating – This rating is used when power and/or rpm are cyclic. The horsepower and the rpm of the engine can be utilized continuously for one hour. This is followed by one hour of operation at the A rating or below the A rating. The engine should be run at full load. The engine should not exceed 50 percent of the duty cycle. Typical applications include the following examples: agricultural tractors, harvesters and combines, off-highway trucks, fire pumps, blast hole drills, rock crushers, wood chippers with high torque rise, and oil field hoisting.

D Rating – This rating is used when rated power is required for periodic overloads. The maximum horsepower and the rpm of the engine can be utilized continuously for a maximum of 30 minutes. This is followed by one hour of operation at the C rating. The engine should be run at full load. The engine should not exceed 10 percent of the duty cycle. Typical applications include the following examples: offshore cranes, runway snow blowers, water well drills, portable air compressors, and fire pump certification power.

E Rating – This rating is used when rated power is required for a short time for initial starting or for sudden overload. The rating is also used for emergency service when standard power is not available. The horsepower and the rpm of the engine can be utilized continuously for a maximum of 15 minutes. This is followed by one hour of operation at the C rating or by the duration of the emergency. The engine should be run at full load. The engine should not exceed 5 percent of the duty cycle. Typical applications include the following examples: standby centrifugal water pumps, oil field well servicing, crash trucks, portable air compressors, and gas turbine starting motors.

NOTICE

Operating engines above the rating definitions can result in shorter service life before overhaul.

Customer Service

i01706971

Customer Assistance

SMCS Code: 1000

USA and Canada

When a problem arises concerning the operation of an engine or concerning the service of an engine, the problem will normally be managed by the dealer in your area.

Your satisfaction is a primary concern to Caterpillar and to Caterpillar dealers. If you have a problem that has not been handled to your complete satisfaction, follow these steps:

1. Discuss your problem with a manager from the dealership.
2. If your problem cannot be resolved at the dealer level without additional assistance, use the phone number that is listed below to talk with a Field Service Coordinator:

1-800-447-4986

The normal hours are from 8:00 to 4:30 Monday through Friday Central Standard Time.

3. If your needs have not been met still, submit the matter in writing to the following address:

Caterpillar Inc.
Manager, Customer Service, Engine Division
Mossville Bldg AC
P.O. Box 610
Mossville, Illinois 61552-0610

Please keep in mind: probably, your problem will ultimately be solved at the dealership, using the dealership's facilities, equipment, and personnel. Therefore, follow the steps in sequence when a problem is experienced.

Outside of the USA and of Canada

If a problem arises outside the USA and outside Canada, and if the problem cannot be resolved at the dealer level, consult the appropriate Caterpillar office.

Latin America, Mexico, Carribean
Caterpillar Americas Co.
701 Waterford Way, Suite 200
Miami, FL 33126-4670
USA
Phone: 305-476-6800
Fax: 305-476-6801

Europe, Africa, and Middle East
Caterpillar Overseas S.A.
76 Route de Frontenex
P.O. Box 6000
CH-1211 Geneva 6
Switzerland
Phone: 22-849-4444
Fax: 22-849-4544

Far East
Caterpillar Asia Pte. Ltd.
7 Tractor Road
Jurong, Singapore 627968
Republic of Singapore
Phone: 65-662-8333
Fax: 65-662-8302

China
Caterpillar China Ltd.
37/F., The Lee Gardens
33 Hysan Avenue
Causeway Bay
G.P.O. Box 3069
Hong Kong
Phone: 852-2848-0333
Fax: 852-2848-0440

Japan
Shin Caterpillar Mitsubishi Ltd.
SBS Tower
10-1, Yoga 4-Chome
Setagaya-Ku, Tokyo 158-8530
Japan
Phone: 81-3-5717-1150
Fax: 81-3-5717-1177

Japan
Caterpillar Power Systems, Inc.
8F, AIG Aoyama Bldg.
2-11-16, Minami-Aoyama
Minato-ku, Tokyo 107-0062
Phone: 81-3-5786-3803
Fax: 81-3-5786-3809

Australia and New Zealand
Caterpillar of Australia Ltd.
1 Caterpillar Drive
Private Mail Bag 4
Tullamarine, Victoria 3043
Australia
Phone: 03-9953-9333
Fax: 03-9335-3366

i01028392

Ordering Replacement Parts

SMCS Code: 7567

WARNING

When replacement parts are required for this product Caterpillar recommends using Caterpillar replacement parts or parts with equivalent specifications including, but not limited to, physical dimensions, type, strength and material.

Failure to heed this warning can lead to premature failures, product damage, personal injury or death.

Quality Caterpillar replacement parts are available from Caterpillar dealers throughout the world. Caterpillar dealers' parts inventories are up-to-date. The parts stocks include all of the parts that are normally needed to protect your Caterpillar engine investment.

When you order parts, please specify the following information:

- Part number
- Part name
- Quantity

If there is a question concerning the part number, please provide your dealer with a complete description of the needed item.

When a Caterpillar engine requires maintenance and/or repair, provide the dealer with all the information that is stamped on the Information Plate. This information is described in this Operation and Maintenance Manual (Product Information Section).

Discuss the problem with the dealer. Inform the dealer about the conditions of the problem and the nature of the problem. Inform the dealer about when the problem occurs. This will help the dealer in troubleshooting the problem and solving the problem faster.

Reference Materials

i01498520

Reference Material

SMCS Code: 1000

The following literature can be obtained through any Caterpillar dealer.

Coolants

- Special Publication, SEBD0970, "Coolant and Your Engine"
- Special Publication, PEHP4036, "Data Sheet-Extended Life Coolant"
- Special Publication, SEBD0518, "Know Your Cooling System"
- Special Publication, PEEP5027, "Label - ELC Radiator Label"
- Special Publication, PEHP7057, "S·O·S Coolant Analysis"

Fuels

- Special Publication, SENR9620, "Improving Fuel System Durability"
- Special Publication, SEBD0717, "Diesel Fuels and Your Engine"

Lubricants

- Special Publication, PEDP7035, "Optimizing Oil Change Intervals"
- Special Publication, PEHP8038, "Data Sheet - Caterpillar Diesel Engine Oils (DEO) (CH-4, CG-4, CF-4) (North America and Australia)"
- Special Publication, PEHP7041, "Product Data Sheet for Caterpillar Diesel Engine Oils (DEO)" CG-4 engine oils (International markets)
- Special Publication, PEWP3014, "Cat Fluids Selector Dial (International)"
- Special Publication, PEWP9733, "Cat Fluids Selector Dial (North America)"
- Special Publication, NEDG6022, "Data Sheet - Multipurpose Lithium Complex Grease (MPG)"

- Special Publication, PEHP0002, "Data Sheet - Multipurpose Lithium Complex Grease with Molybdenum (MPGM)"
- Special Publication, PEHP0017, "Data Sheet - Special Purpose Grease (SPG) Bearing Lubricant"
- Special Publication, NEHP5621, "How To Select The Right Grease For Any Job"
- Special Publication, PEHP6001, "How To Take A Good Oil Sample"
- Special Publication, SEBD0640, "Oil and Your Engine"
- Special Publications, PEDP7036, "S·O·S Fluids Analysis Cornerstone"

Miscellaneous

- Service Manual, SENR9595, "C-9 Industrial Engine Service Manual"
- Special Publication, SEBU6251, "Caterpillar Commercial Diesel Engine Fluids Recommendations For Lubricants, Diesel Fuel, and Coolants"
- Special Publication, PECP6026, "One Safe Source"
- Special Instruction, SMHS7001, "Assembly of Fan Drive Pulley Assemblies"
- Special Instruction, SEHS7633, "Battery Test Procedure"
- Special Publication, SEBF8062, "Guideline for Reusable Parts - Procedure to Inspect and Clean Air Filters"
- Special Publication, SEBF8029, "Index to Guidelines for Reusable Parts and Salvage Operations"
- Special Publication, PEDP0026, "Power Analysis Report"
- Special Publication, NEHS0526, "Service Technology Application Guide"
- Special Instruction, SEHS9031, "Storage Procedure for Caterpillar Products"
- Specifications, SENR3130, "Torque Specifications Module"
- Special Instruction, SEHS7768, "Use of 6V-2150 Starting/Charging Analyzer"

- Special Instruction, SEHS8742, "Using the 8T-8697 Electronic Control Analyzer Programmer (ECAP)"
- Special Instruction, SEHS8622, "Using the FT-1984 Air-To-Air Aftercooler Leak Test Group"
- Special Instruction, SEHS7332, "Warning Tag - Danger Do Not Operate"
- Special Instruction, REHS0871, "Electronic Installation Guide".

International Organization for Standardization (ISO)
1, rue de Varembe
Case postale 56
CH-1211 Genève 20
Switzerland
Telephone: +41 22 749 01 11
Facsimile: +41 22 733 34 30
E-mail: central@iso.ch
Web site: <http://www.iso.ch>

European classifications are established by the Conseil International Des Machines a Combustion (CIMAC) (International Council on Combustion Engines).

i01109461

Additional Reference Material

SMCS Code: 1000

The "EMA Lubricating Oils Data Book" can be obtained from the following locations: local technological society, local library, and local college. If necessary, consult EMA at the following address:

Engine Manufacturers Association
401 N. Michigan Ave.
Chicago, IL, USA 60611
Telephone: (312) 644-6610 ext. 3626

The "Society of Automotive Engineers (SAE) Specifications" can be found in your SAE handbook. This publication can also be obtained from the following locations: local technological society, local library, and local college. If necessary, consult SAE at the following address:

SAE International
400 Commonwealth Drive
Warrendale, PA, USA 15096-0001
Telephone: (724) 776-4841

The "American Petroleum Institute Publication No. 1509" can be obtained from the following locations: local technological society, local library, and local college. If necessary, consult API at the following address:

American Petroleum Institute
1220 L St. N.W.
Washington, DC, USA 20005
Telephone: (202) 682-8000

The International Organization for Standardization (ISO) offers information and customer service regarding international standards and standardizing activities. ISO can also supply information on the following subjects that are not controlled by ISO: national standards, regional standards, regulations, certification, and related activities. Consult the member of ISO in your country.

CIMAC Central Secretariat
Lyoner Strasse 18
60528 Frankfurt
Germany
Telephone: +49 69 6603 1567
Facsimile: +49 69 6603 1566

i00912149

Maintenance Records

SMCS Code: 1000

Caterpillar Inc. recommends the retention of accurate maintenance records. Accurate maintenance records can be used for the following purposes:

- Determine operating costs.
- Establish maintenance schedules for other engines that are operated in the same environment.
- Show compliance with the required maintenance practices and maintenance intervals.

Maintenance records can be used for a variety of other business decisions that are related to engine maintenance.

Maintenance records are a key element of a maintenance program that is well managed. Accurate maintenance records can help your Caterpillar dealer to fine tune the recommended maintenance intervals in order to meet the specific operating situation. This should result in a lower engine operating cost.

Records should be kept for the following items:

Fuel Consumption – A record of fuel consumption is essential in order to determine when the load sensitive components should be inspected or repaired. Fuel consumption also determines overhaul intervals.

Service Hours – A record of service hours is essential to determine when the speed sensitive components should be inspected or repaired.

Documents – These items should be easy to obtain, and these items should be kept in the engine history file. All of the documents should show this information: date, service hours, fuel consumption, unit number, and engine serial number. The following types of documents should be kept as proof of maintenance or repair for warranty:

Keep the following types of documents as proof of maintenance for warranty. Also, keep these types of documents as proof of repair for warranty:

- Dealer work orders and itemized bills
- Owner's repair costs
- Owner's receipts
- Maintenance log

Index

A

Additional Reference Material	117
After Starting Engine	44
After Stopping Engine.....	47
Aftercooler Core - Clean/Test	74
Aftercooler Core - Inspect.....	74
Aftermarket Oil Additives	54
Air Compressor - Inspect.....	75
Air Compressor Filter - Clean/Replace (If Equipped)	75
Air Tank Moisture and Sediment - Drain (If Equipped)	76
Alternator - Inspect	76

B

Battery - Replace.....	76
Battery Charger - Check.....	78
Checking After Stopping	78
Checking Before Start-Up.....	78
Battery Electrolyte Level - Check	77
Battery or Battery Cable - Disconnect.....	77
Before Starting Engine	13, 39
Belt - Inspect.....	78
Adjustment.....	79
Inspection.....	78
Belt Tensioner - Inspect (If Equipped)	80
Burn Prevention.....	10
Batteries.....	10
Coolant.....	10
Oils.....	10

C

Cold Weather Lubricants	54
Cold Weather Operation.....	48
Commercial Heavy-Duty Coolant/Antifreeze and SCA	66
Conventional Coolant/Antifreeze Cooling System Maintenance	68
Cleaning the System of Heavy-Duty Coolant/Antifreeze	70
Cooling Systems with Larger Capacities	69
Coolant Recommendations	61
Cooling System Coolant (DEAC) - Change	80
Cooling Systems with Heavy Deposits or Plugging	81
Drain	81
Fill	82
Flush	81
Cooling System Coolant (ELC) - Change.....	82
Drain	82
Fill	83
Flush	83
Cooling System Coolant Extender (ELC) - Add.....	84

Cooling System Coolant Level - Check	84
Cooling System Specifications	59
Cooling System Supplemental Coolant Additive (SCA) - Test/Add.....	85
Add the SCA, If Necessary	85
S-O-S Coolant Analysis.....	85
Test for SCA Concentration	85
Cooling System Water Temperature Regulator - Replace.....	86
Crankshaft Vibration Damper - Inspect	86
Removal and Installation.....	86
Visconic Damper.....	87
Crushing Prevention and Cutting Prevention.....	12
Customer Assistance.....	114
Outside of the USA and of Canada.....	114
USA and Canada	114
Customer Service.....	114
Customer Specified Parameters.....	23, 38
Cylinder Head Grounding Stud - Inspect/Clean/Tighten.....	87

D

Diagnostic Flash Code Retrieval	34
“Diagnostic” Lamp.....	34
Diagnostic Lamp.....	34
Diesel Engine Antifreeze/Coolant (DEAC)	65
Driven Equipment - Check.....	87

E

Electrical System.....	14
Grounding Practices	14
Emergency Stopping	46
Emergency Stop Button	46
Emissions Certification Film	22
Emissions Warranty Information.....	111
Engaging the Driven Equipment.....	45
Engine - Clean.....	87
Engine Air Cleaner Element (Dual Element) - Clean/Replace	88
Cleaning the Primary Air Cleaner Elements	89
Servicing the Air Cleaner Elements.....	88
Engine Air Cleaner Service Indicator - Inspect.....	90
Test the Service Indicator	91
Engine Crankcase Breather - Clean.....	91
Engine Description	18
Aftermarket Products and Caterpillar Engines... ..	20
Electronic Engine Features.....	19
Engine Cooling and Lubrication	20
Engine Service Life	20
Engine Specifications.....	18
Welding and Caterpillar Electronic Engines.....	20
Engine Diagnostics.....	34
Engine Electronics.....	15
Engine Features and Controls.....	30

Engine Identification	21	Foreword.....	5
Engine Lifting.....	25	California Proposition 65 Warning	5
Engine Lifting and Storage	25	Literature Information.....	4
Engine Monitoring System (EMS)	27	Maintenance	4
Communication Data Link.....	29	Maintenance Intervals.....	4
EMS Main Unit.....	28	Operation	4
Quad Gauge Unit.....	28	Overhaul	4
Tachometer Unit.....	29	Safety	4
Engine Mounts - Inspect.....	91	Fuel and the Effect from Cold Weather	48
Engine Oil	50	Fuel Recommendations.....	57
Caterpillar Diesel Engine Oil.....	50	Fuel Related Components in Cold Weather	49
Commercial Oils.....	51	Fuel Filters	49
Total Base Number (TBN) and Fuel Sulfur Levels for Direct Injection (DI) Diesel Engines	52	Fuel Heaters	49
Engine Oil and Filter - Change	93	Fuel Tanks.....	49
Drain the Engine Oil.....	95	Fuel Specifications	57
Fill the Engine Crankcase	96	Fuel System - Prime.....	98
Oil Grade Plug	94	Engines that are Equipped with a Fuel Priming Pump.....	98
Replace the Oil Filter	95	Engines that are Not Equipped with a Fuel Priming Pump.....	99
Selection of Oil Change Interval	93	Fuel System Primary Filter/Water Separator - Drain	99
Engine Oil Level - Check	92	Fuel System Primary Filter/Water Separator Element - Replace	100
Engine Oil Sample - Obtain	92	Replace the Element.....	100
Obtain the Sample and the Analysis.....	92	Fuel System Secondary Filter - Replace.....	101
Engine Operation.....	45	Fuel Tank Water and Sediment - Drain.....	102
Engine Operation with Active Diagnostic Codes ...	37	Drain the Water and the Sediment.....	102
Engine Operation with Intermittent Diagnostic Codes	37	Fuel Storage Tanks	102
Engine Rating Conditions	112	Fuel Tank	102
Engine Rating Definitions	112	G	
Engine Ratings	112	Gauges and Indicators	26
Engine Starting.....	13, 39	General Coolant Information	59
Ether	13	Additives	60
Engine Stopping	14, 46	Glycol	60
Engine Storage.....	25	Water	59
Engine Storage Procedure - Check.....	97	General Hazard Information	7
Engine Valve Lash - Inspect/Adjust	97	Asbestos Information	9
Engine Valve Rotators - Inspect	97	Containing Fluid Spillage	9
Ether Starting Aid Cylinder - Replace (If Equipped)	98	Dispose of Waste Properly	10
Extended Life Coolant (ELC).....	62	Fluid Penetration	9
Extended Life Coolant (ELC) Cooling System Maintenance	63	Pressure Air and Water.....	8
Caterpillar ELC Extender	63	General Information.....	17
Changing to Caterpillar ELC	64	H	
Commercial ELC.....	65	Hoses and Clamps - Inspect/Replace	102
ELC Cooling System Cleaning.....	64	Replace the Hoses and the Clamps	103
ELC Cooling System Contamination.....	65	I	
Proper additions to the Extended Life Coolant ..	63	Important Safety Information	2
F		Information Plate	21
Fan Drive Bearing - Lubricate.....	98		
Fault Logging.....	36		
Fire Prevention and Explosion Prevention.....	10		
Ether	12		
Fire Extinguisher	12		
Lines, Tubes and Hoses.....	12		

J		Refill Capacities.....	71
Jacket Water Heater - Check.....	103	Cooling System.....	71
		Lubrication System	71
L		S	
Lubricant Information.....	50	S-O-S Coolant Analysis	61
API Oils	50	New Systems, Refilled Systems, and Converted	
Engine Manufacturers Association (EMA) Oils ..	50	Systems	62
General Information	50	Recommended Interval for S-O-S Coolant	
Lubricant Specifications	50	Sample	62
Lubricating Grease	54	S-O-S Coolant Analysis (Level 1).....	62
Caterpillar Premium Grease (CPG).....	56	S-O-S Coolant Analysis (Level 2).....	62
Multipurpose Greases.....	55	S-O-S Oil Analysis	56
Special Purpose Grease (SPG).....	55	Safety Section	6
		Safety Signs and Labels.....	6
M		Sensors and Electrical Components	30
Maintenance Interval Schedule	72	Atmospheric Pressure Sensor	31
Maintenance Log	119	Coolant Temperature Sensor	31
Maintenance Records.....	117	Crankshaft Position Sensor and Camshaft Position	
Maintenance Section	50	Sensor.....	32
Manual Stop Procedure.....	47	Engine Oil Pressure Sensor.....	32
Model View Illustrations.....	18	Engine Oil Temperature Sensor.....	32
Model Views	18	Failure of Sensors	31
Mounting and Dismounting.....	13	Injection Actuation Pressure Sensor.....	32
		Inlet Air Temperature Sensor	32
O		Programmable Monitoring System (PMS)	31
Operation Section.....	25	Sensor Locations.....	30
Ordering Replacement Parts	115	Throttle Position Sensor.....	32
Overhaul Considerations	103	Turbocharger Outlet Pressure Sensor	31
Oil Consumption as an Overhaul Indicator	104	Serial Number Plate	21
Overhaul Recommendation	104	Severe Service Application - Check	107
		Environmental Factors	108
P		Improper Maintenance Procedures.....	108
Power Take-Off Clutch - Check/Adjust/Lubricate..	106	Improper Operating Procedures	108
Product Identification Information	21	Starting Motor - Inspect.....	108
Product Information Section	17	Starting the Engine.....	40
		Air Inlet Heater	40
R		Cold Weather Starting	40
Radiator - Clean	107	Ether Injection System	41
Radiator Restrictions	48	Initial Inspection	40
Re-refined Base Stock Oils	53	Problems with the Wiring Harness.....	42
Reference Information Section	112	Starting Problems	42
Reference Material	116	Starting with Jump Start Cables	43
Coolants.....	116	Stopping the Engine	46
Fuels	116	Supplemental Coolant Additive (SCA).....	65
Lubricants	116	Synthetic Base Stock Oils	53
Miscellaneous	116		
Reference Materials	116	T	
Reference Numbers	21	Table of Contents.....	3
Record for Reference.....	21	Turbocharger - Inspect.....	108
		Cleaning and Inspecting	109
		Removal and Installation.....	109

W

Walk-Around Inspection	109
Inspect the Engine for Leaks and for Loose Connections	109
Warranty Information	111
Warranty Section	111
Water Pump - Inspect.....	110
Water/Supplemental Coolant Additive (SCA)	66
Cooling Systems with Larger Capacities	67
Welding on Engines with Electronic Controls	17

Product and Dealer Information

Note: For product identification plate locations, see the section "Product Identification Information" in the Operation and Maintenance Manual.

Delivery Date: _____

Product Information

Model: _____

Product Identification Number: _____

Engine Serial Number: _____

Transmission Serial Number: _____

Generator Serial Number: _____

Attachment Serial Numbers: _____

Attachment Information: _____

Customer Equipment Number: _____

Dealer Equipment Number: _____

Dealer Information

Name: _____ Branch: _____

Address: _____

Dealer Contact

Phone Number

Hours

Sales: _____

Parts: _____

Service: _____

